

Cree® XLamp® XB-D LEDs



TABLE OF CONTENTS

Introduction.....	1
Bin and Order-Code Format	2
Performance Groups – Luminous or Radiant Flux.....	3
Performance Groups – Dominant Wavelength	4
Performance Groups – Forward Voltage	4
Performance Groups – Chromaticity	5
Cree’s Standard Chromaticity Regions Plotted on the 1931 CIE Curve.....	8
Cree’s Standard Cool White Kits Plotted on ANSI Standard Chromaticity Regions.....	9
Cree’s Outdoor White Kits Plotted on ANSI Standard Chromaticity Regions	10
Cree’s Standard Warm and Neutral White Kits Plotted on ANSI Standard Chromaticity Regions	12
Cree’s Standard Chromaticity Kits	13
Standard Order Codes and Bins (XB-D ANSI Cool White, $T_j = 85\text{ }^\circ\text{C}$).....	13
Standard Order Codes and Bins (XB-D Neutral White, $T_j = 85\text{ }^\circ\text{C}$).....	14
Standard Order Codes and Bins (XB-D Warm White, $T_j = 85\text{ }^\circ\text{C}$).....	15
Standard Order Codes and Bins (XB-D Color, $T_j = 25\text{ }^\circ\text{C}$).....	16

INTRODUCTION

This document describes the product nomenclature required to select and order Cree’s XLamp XB-D LEDs. XLamp XB-D LEDs are tested and sorted into bins which are then combined into orderable kits, identified by an order code.

All XLamp LEDs are tested and sorted by color and brightness into a unique bin. Each bin contains LEDs from only one color and brightness group and is uniquely identified by a bin code. White XLamp LEDs are sorted by chromaticity (color) and luminous flux (brightness). Color XLamp LEDs are sorted by dominant wavelength (color) and luminous or radiant flux (brightness). LEDs are shipped in reels containing LEDs from a single bin and labeled with the corresponding bin code. XLamp LED packaging details are provided in product data sheets.

Kits contain LEDs from a number of similar bins and are fully defined by their order codes. A full explanation of the order codes for XLamp XB Family LEDs, as well as a list of standard order codes, is provided in this document.

BIN AND ORDER-CODE FORMAT

Bin codes and order codes for XB-D LEDs are configured in the following manner:

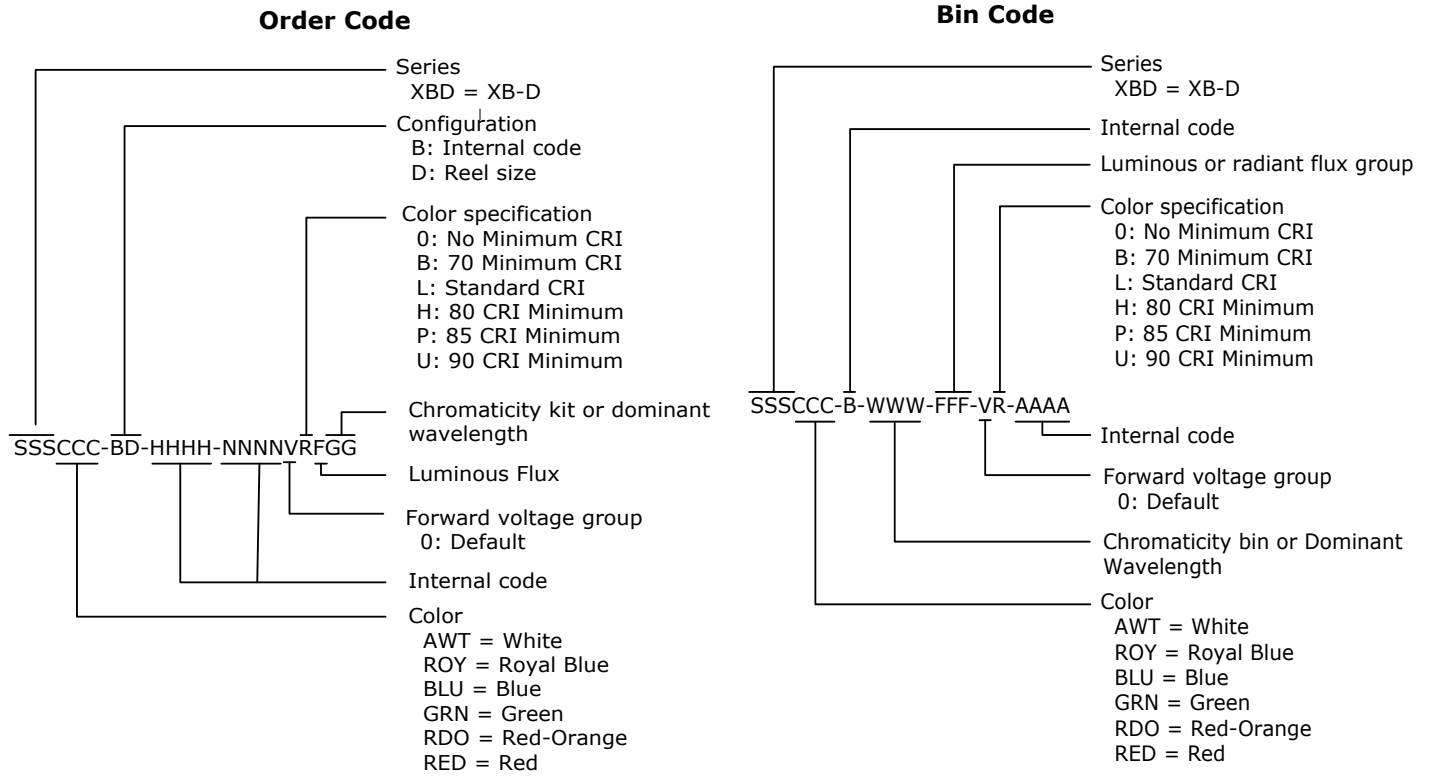

Example Order Code: XBDAWT-00-0000-00000HAE7

Example Bin Code: XBDAWT-0-7A3-Q20-0H-0001

PERFORMANCE GROUPS – LUMINOUS OR RADIANT FLUX

XLamp XB-D LEDs, except Royal Blue, are tested for luminous flux and placed into one of the following luminous-flux groups. These groups, pre-pended with a 0, are used in the Bin Code “Luminous or radiant flux group.”

Group Code	Min. Luminous Flux @ 350 mA (lm)	Max. Luminous Flux @ 350 mA (lm)
K2	30.6	35.2
K3	35.2	39.8
M2	39.8	45.7
M3	45.7	51.7
N2	51.7	56.8
N3	56.8	62
N4	62	67.2
P2	67.2	73.9
P3	73.9	80.6
P4	80.6	87.4
Q2	87.4	93.9
Q3	93.9	100
Q4	100	107
Q5	107	114
R2	114	122
R3	122	130
R4	130	139
R5	139	148
S2	148	156

Royal-blue XLamp LEDs are tested for radiant flux and sorted into one of the following radiant-flux bins.

Group	Min. Radiant Flux (mW) @ 350 mA	Max. Radiant Flux (mW) @ 350 mA
30	450	475
31	475	500
32	500	525
33	525	550
34	550	575
35	575	600
36	600	625
37	625	650
38	650	675
39	675	700
40	700	725

PERFORMANCE GROUPS – DOMINANT WAVELENGTH

Color XLamp LEDs are tested for dominant wavelength (DWL) and sorted into one of the DWL bins defined below.

Color	DWL Group	Min. DWL (nm) @ 350 mA	Max. DWL (nm) @ 350 mA
Royal Blue	D36	450	452.5
	D37	452.5	455
	D46	455	457.5
	D47	457.5	460
	D56	460	462.5
	D57	462.5	465
Blue	B3	465	470
	B4	470	475
	B5	475	480
	B6	480	485
Green	G2	520	525
	G3	525	530
	G4	530	535
Amber	A2	585	590
	A3	590	595
Red-Orange	O3	610	615
	O4	615	620
Red	R2	620	625
	R3	625	630

PERFORMANCE GROUPS – FORWARD VOLTAGE

Amber, red-orange, red and royal blue XLamp XB-D LEDs are tested for forward voltage and sorted into one of the forward voltage bins defined below.

Forward Voltage Group	Min. Forward Voltage @ 350 mA	Max. Forward Voltage @ 350 mA
B	1.75	2.0
C	2.0	2.25
D	2.25	2.5
E	2.5	2.75
F	2.75	3.0
G	3.0	3.25
H	3.25	3.5

PERFORMANCE GROUPS – CHROMATICITY

Region	x	y	Region	x	y	Region	x	y	Region	x	y
0A	0.2950	0.2970	0B	0.2920	0.3060	0C	0.2984	0.3133	0D	0.2984	0.3133
	0.2920	0.3060		0.2895	0.3135		0.2962	0.3220		0.3048	0.3207
	0.2984	0.3133		0.2962	0.3220		0.3028	0.3304		0.3068	0.3113
	0.3009	0.3042		0.2984	0.3133		0.3048	0.3207		0.3009	0.3042
0R	0.2980	0.2880	0S	0.2895	0.3135	0T	0.2962	0.3220	0U	0.3037	0.2937
	0.2950	0.2970		0.2870	0.3210		0.2937	0.3312		0.3009	0.3042
	0.3009	0.3042		0.2937	0.3312		0.3005	0.3415		0.3068	0.3113
	0.3037	0.2937		0.2962	0.3220		0.3028	0.3304		0.3093	0.2993
1A	0.3048	0.3207	1B	0.3028	0.3304	1C	0.3115	0.3391	1D	0.3130	0.3290
	0.3130	0.3290		0.3115	0.3391		0.3205	0.3481		0.3213	0.3373
	0.3144	0.3186		0.3130	0.3290		0.3213	0.3373		0.3221	0.3261
	0.3068	0.3113		0.3048	0.3207		0.3130	0.3290		0.3144	0.3186
1R	0.3068	0.3113	1S	0.3005	0.3415	1T	0.3099	0.3509	1U	0.3144	0.3186
	0.3144	0.3186		0.3099	0.3509		0.3196	0.3602		0.3221	0.3261
	0.3161	0.3059		0.3115	0.3391		0.3205	0.3481		0.3231	0.3120
	0.3093	0.2993		0.3028	0.3304		0.3115	0.3391		0.3161	0.3059
2A	0.3215	0.3350	2B	0.3207	0.3462	2C	0.3290	0.3538	2D	0.3290	0.3417
	0.3290	0.3417		0.3290	0.3538		0.3376	0.3616		0.3371	0.3490
	0.3290	0.3300		0.3290	0.3417		0.3371	0.3490		0.3366	0.3369
	0.3222	0.3243		0.3215	0.3350		0.3290	0.3417		0.3290	0.3300
2R	0.3222	0.3243	2S	0.3196	0.3602	2T	0.3290	0.3690	2U	0.3290	0.3300
	0.3290	0.3300		0.3290	0.3690		0.3381	0.3762		0.3366	0.3369
	0.3290	0.3180		0.3290	0.3538		0.3376	0.3616		0.3361	0.3245
	0.3231	0.3120		0.3207	0.3462		0.3290	0.3538		0.3290	0.3180
3A	0.3371	0.3490	3B	0.3376	0.3616	3C	0.3463	0.3687	3D	0.3451	0.3554
	0.3451	0.3554		0.3463	0.3687		0.3551	0.3760		0.3533	0.3620
	0.3440	0.3427		0.3451	0.3554		0.3533	0.3620		0.3515	0.3487
	0.3366	0.3369		0.3371	0.3490		0.3451	0.3554		0.3440	0.3427
3R	0.3366	0.3369	3S	0.3381	0.3762	3T	0.3480	0.3840	3U	0.3440	0.3428
	0.3440	0.3428		0.3480	0.3840		0.3571	0.3907		0.3515	0.3487
	0.3429	0.3307		0.3463	0.3687		0.3551	0.3760		0.3495	0.3339
	0.3361	0.3245		0.3376	0.3616		0.3463	0.3687		0.3429	0.3307
4A	0.3530	0.3597	4B	0.3548	0.3736	4C	0.3641	0.3804	4D	0.3615	0.3659
	0.3615	0.3659		0.3641	0.3804		0.3736	0.3874		0.3702	0.3722
	0.3590	0.3521		0.3615	0.3659		0.3702	0.3722		0.3670	0.3578
	0.3512	0.3465		0.3530	0.3597		0.3615	0.3659		0.3590	0.3521
4R	0.3512	0.3465	4S	0.3571	0.3907	4T	0.3668	0.3957	4U	0.3590	0.3521
	0.3590	0.3521		0.3668	0.3957		0.3771	0.4034		0.3670	0.3578
	0.3567	0.3389		0.3641	0.3804		0.3736	0.3874		0.3640	0.3440
	0.3495	0.3339		0.3548	0.3736		0.3641	0.3804		0.3567	0.3389

PERFORMANCE GROUPS – CHROMATICITY (CONTINUED)

Region	x	y	Region	x	y	Region	x	y	Region	x	y
5A1	0.3670	0.3578	5A2	0.3686	0.3649	5A3	0.3744	0.3685	5A4	0.3726	0.3612
	0.3686	0.3649		0.3702	0.3722		0.3763	0.3760		0.3744	0.3685
	0.3744	0.3685		0.3763	0.3760		0.3825	0.3798		0.3804	0.3721
	0.3726	0.3612		0.3744	0.3685		0.3804	0.3721		0.3783	0.3646
5B1	0.3702	0.3722	5B2	0.3719	0.3797	5B3	0.3782	0.3837	5B4	0.3763	0.3760
	0.3719	0.3797		0.3736	0.3874		0.3802	0.3916		0.3782	0.3837
	0.3782	0.3837		0.3802	0.3916		0.3869	0.3958		0.3847	0.3877
	0.3763	0.3760		0.3782	0.3837		0.3847	0.3877		0.3825	0.3798
5C1	0.3825	0.3798	5C2	0.3847	0.3877	5C3	0.3912	0.3917	5C4	0.3887	0.3836
	0.3847	0.3877		0.3869	0.3958		0.3937	0.4001		0.3912	0.3917
	0.3912	0.3917		0.3937	0.4001		0.4006	0.4044		0.3978	0.3958
	0.3887	0.3836		0.3912	0.3917		0.3978	0.3958		0.3950	0.3875
5D1	0.3783	0.3646	5D2	0.3804	0.3721	5D3	0.3863	0.3758	5D4	0.3840	0.3681
	0.3804	0.3721		0.3825	0.3798		0.3887	0.3836		0.3863	0.3758
	0.3863	0.3758		0.3887	0.3836		0.3950	0.3875		0.3924	0.3794
	0.3840	0.3681		0.3863	0.3758		0.3924	0.3794		0.3898	0.3716
5R	0.3670	0.3578	5S	0.3771	0.4034	5T	0.3916	0.4127	5U	0.3783	0.3646
	0.3783	0.3646		0.3916	0.4127		0.4064	0.4221		0.3898	0.3716
	0.3743	0.3502		0.3869	0.3958		0.4006	0.4044		0.3848	0.3565
	0.3640	0.3440		0.3736	0.3874		0.3869	0.3958		0.3743	0.3502
6A1	0.3889	0.3690	6A2	0.3915	0.3768	6A3	0.3981	0.3800	6A4	0.3953	0.3720
	0.3915	0.3768		0.3941	0.3848		0.4010	0.3882		0.3981	0.3800
	0.3981	0.3800		0.4010	0.3882		0.4080	0.3916		0.4048	0.3832
	0.3953	0.3720		0.3981	0.3800		0.4048	0.3832		0.4017	0.3751
6B1	0.3941	0.3848	6B2	0.3968	0.3930	6B3	0.4040	0.3966	6B4	0.4010	0.3882
	0.3968	0.3930		0.3996	0.4015		0.4071	0.4052		0.4040	0.3966
	0.4040	0.3966		0.4071	0.4052		0.4146	0.4089		0.4113	0.4001
	0.4010	0.3882		0.4040	0.3966		0.4113	0.4001		0.4080	0.3916
6C1	0.4080	0.3916	6C2	0.4113	0.4001	6C3	0.4186	0.4037	6C4	0.4150	0.3950
	0.4113	0.4001		0.4146	0.4089		0.4222	0.4127		0.4186	0.4037
	0.4186	0.4037		0.4222	0.4127		0.4299	0.4165		0.4259	0.4073
	0.4150	0.3950		0.4186	0.4037		0.4259	0.4073		0.4221	0.3984
6D1	0.4017	0.3751	6D2	0.4048	0.3832	6D3	0.4116	0.3865	6D4	0.4082	0.3782
	0.4048	0.3832		0.4080	0.3916		0.4150	0.3950		0.4116	0.3865
	0.4116	0.3865		0.4150	0.3950		0.4221	0.3984		0.4183	0.3898
	0.4082	0.3782		0.4116	0.3865		0.4183	0.3898		0.4147	0.3814

PERFORMANCE GROUPS – CHROMATICITY (CONTINUED)

Region	x	y	Region	x	y	Region	x	y	Region	x	y
6R	0.3889	0.3690	6S	0.4054	0.4191	6T	0.4217	0.4273	6U	0.4017	0.3751
	0.4017	0.3751		0.4217	0.4273		0.4382	0.4356		0.4147	0.3814
	0.3957	0.3596		0.4146	0.4089		0.4299	0.4165		0.4077	0.3652
	0.3840	0.3540		0.3996	0.4015		0.4146	0.4089		0.3957	0.3596
7A1	0.4147	0.3814	7A2	0.4183	0.3898	7A3	0.4242	0.3919	7A4	0.4203	0.3833
	0.4183	0.3898		0.4221	0.3984		0.4281	0.4006		0.4242	0.3919
	0.4242	0.3919		0.4281	0.4006		0.4342	0.4028		0.4300	0.3939
	0.4203	0.3833		0.4242	0.3919		0.4300	0.3939		0.4259	0.3853
7B1	0.4221	0.3984	7B2	0.4259	0.4073	7B3	0.4322	0.4096	7B4	0.4281	0.4006
	0.4259	0.4073		0.4299	0.4165		0.4364	0.4188		0.4322	0.4096
	0.4322	0.4096		0.4364	0.4188		0.4430	0.4212		0.4385	0.4119
	0.4281	0.4006		0.4322	0.4096		0.4385	0.4119		0.4342	0.4028
7C1	0.4342	0.4028	7C2	0.4385	0.4119	7C3	0.4449	0.4141	7C4	0.4403	0.4049
	0.4385	0.4119		0.4430	0.4212		0.4496	0.4236		0.4449	0.4141
	0.4449	0.4141		0.4496	0.4236		0.4562	0.4260		0.4513	0.4164
	0.4403	0.4049		0.4449	0.4141		0.4513	0.4164		0.4465	0.4071
7D1	0.4259	0.3853	7D2	0.4300	0.3939	7D3	0.4359	0.3960	7D4	0.4316	0.3873
	0.4300	0.3939		0.4342	0.4028		0.4403	0.4049		0.4359	0.3960
	0.4359	0.3960		0.4403	0.4049		0.4465	0.4071		0.4418	0.3981
	0.4316	0.3873		0.4359	0.3960		0.4418	0.3981		0.4373	0.3893
8A1	0.4373	0.3893	8A2	0.4418	0.3981	8A3	0.4475	0.3994	8A4	0.4428	0.3906
	0.4418	0.3981		0.4465	0.4071		0.4523	0.4085		0.4475	0.3994
	0.4475	0.3994		0.4523	0.4085		0.4582	0.4099		0.4532	0.4008
	0.4428	0.3906		0.4475	0.3994		0.4532	0.4008		0.4483	0.3919
8B1	0.4465	0.4071	8B2	0.4513	0.4164	8B3	0.4573	0.4178	8B4	0.4523	0.4085
	0.4513	0.4164		0.4562	0.4260		0.4624	0.4274		0.4573	0.4178
	0.4573	0.4178		0.4624	0.4274		0.4687	0.4289		0.4634	0.4193
	0.4523	0.4085		0.4573	0.4178		0.4634	0.4193		0.4582	0.4099
8C1	0.4582	0.4099	8C2	0.4634	0.4193	8C3	0.4695	0.4207	8C4	0.4641	0.4112
	0.4634	0.4193		0.4687	0.4289		0.4750	0.4304		0.4695	0.4207
	0.4695	0.4207		0.4750	0.4304		0.4813	0.4319		0.4756	0.4221
	0.4641	0.4112		0.4695	0.4207		0.4756	0.4221		0.4700	0.4126
8D1	0.4483	0.3919	8D2	0.4532	0.4008	8D3	0.4589	0.4021	8D4	0.4538	0.3931
	0.4532	0.4008		0.4582	0.4099		0.4641	0.4112		0.4589	0.4021
	0.4589	0.4021		0.4641	0.4112		0.4700	0.4126		0.4646	0.4034
	0.4538	0.3931		0.4589	0.4021		0.4646	0.4034		0.4593	0.3944

CREE'S STANDARD CHROMATICITY REGIONS PLOTTED ON THE 1931 CIE CURVE

ANSI Cool White

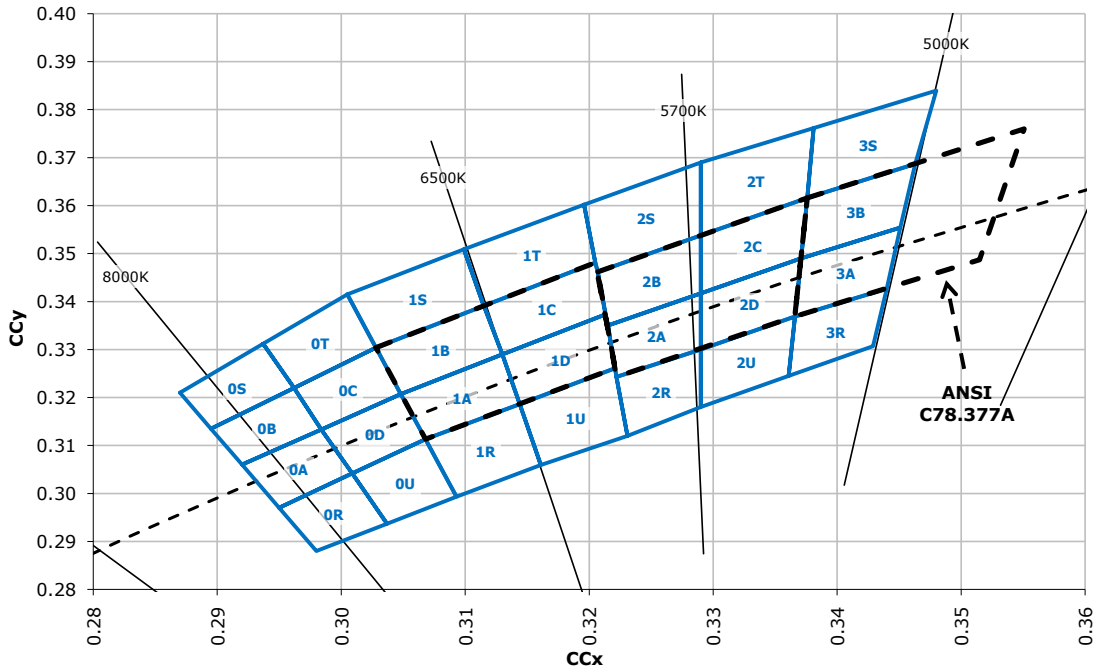

ANSI Neutral White and ANSI Warm White

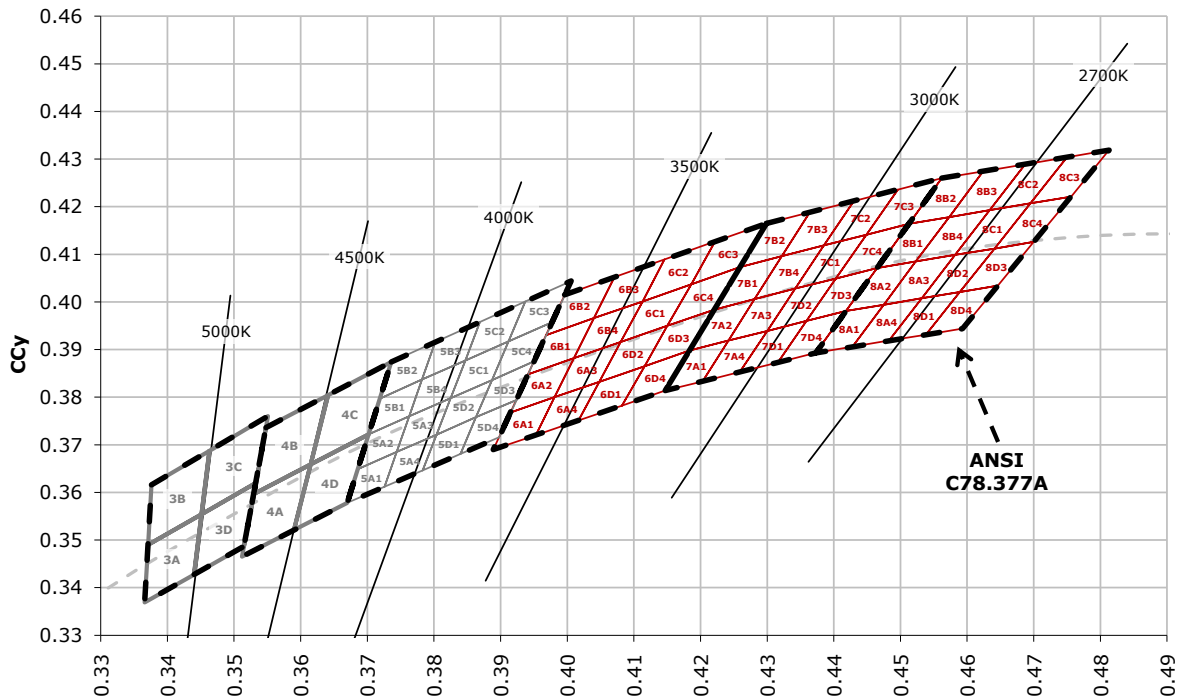

Outdoor White

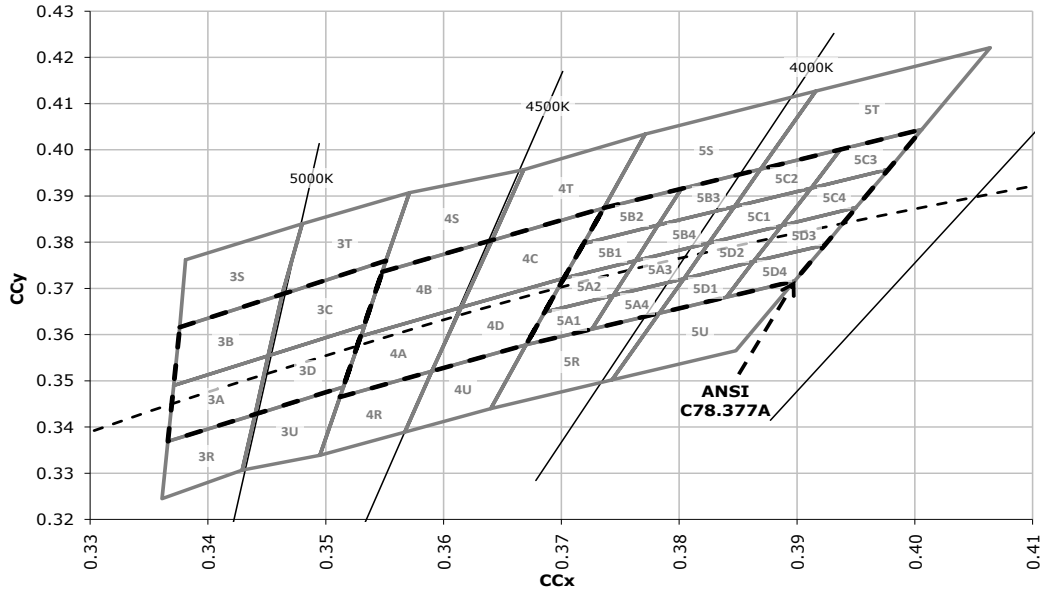

CREE'S STANDARD COOL WHITE KITS PLOTTED ON ANSI STANDARD CHROMATICITY REGIONS

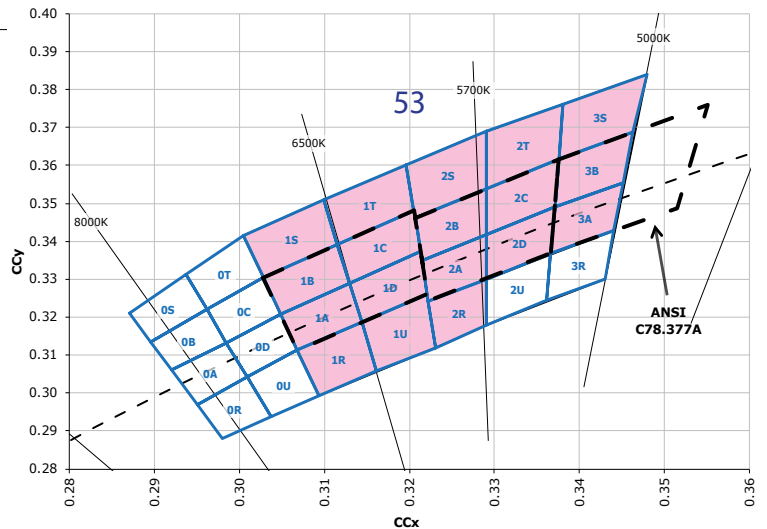
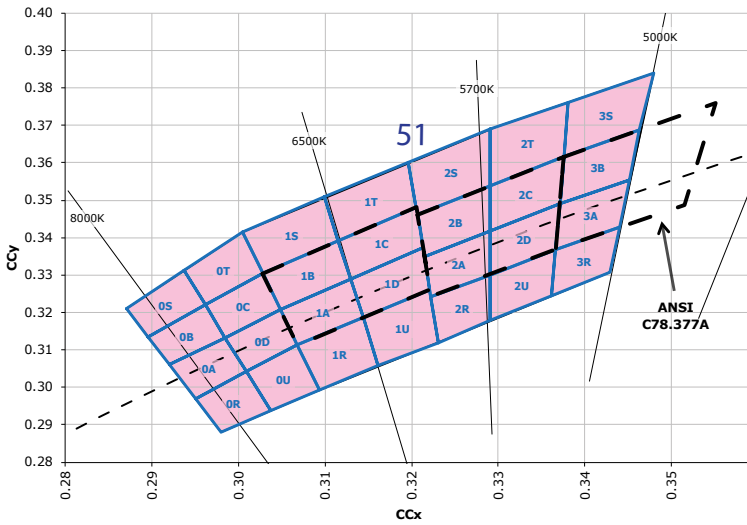

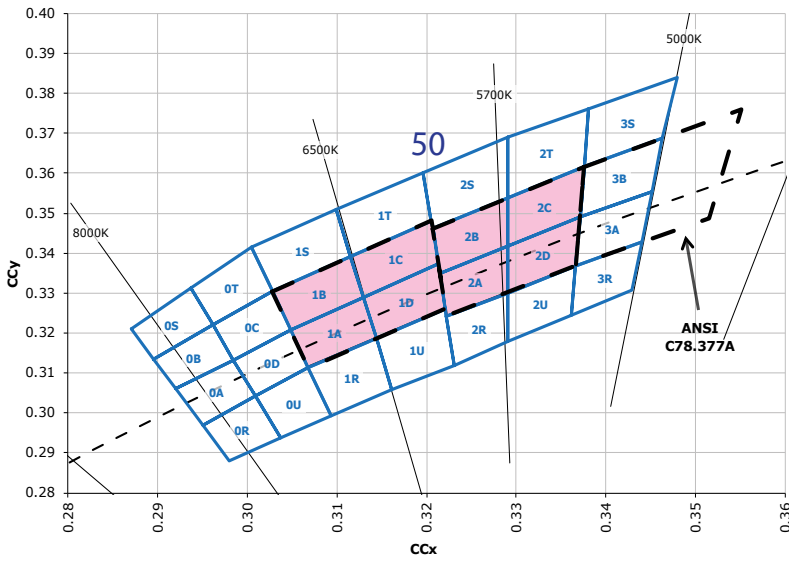

CREE'S OUTDOOR WHITE KITS PLOTTED ON ANSI STANDARD CHROMATICITY REGIONS

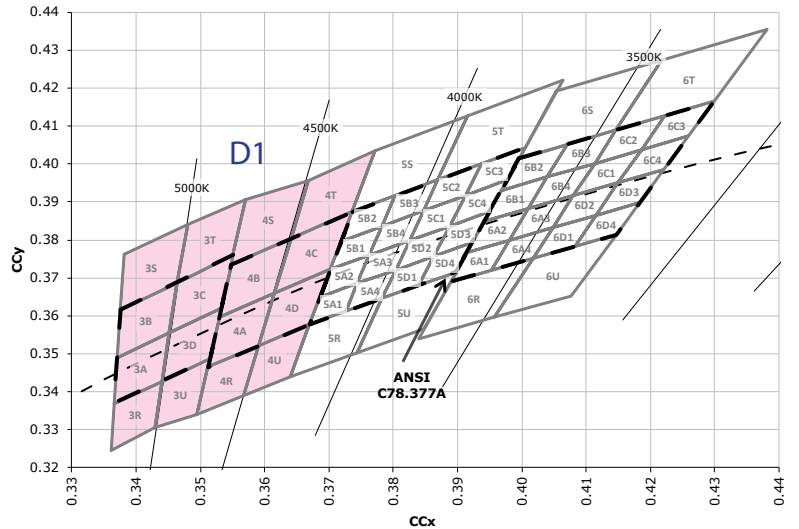
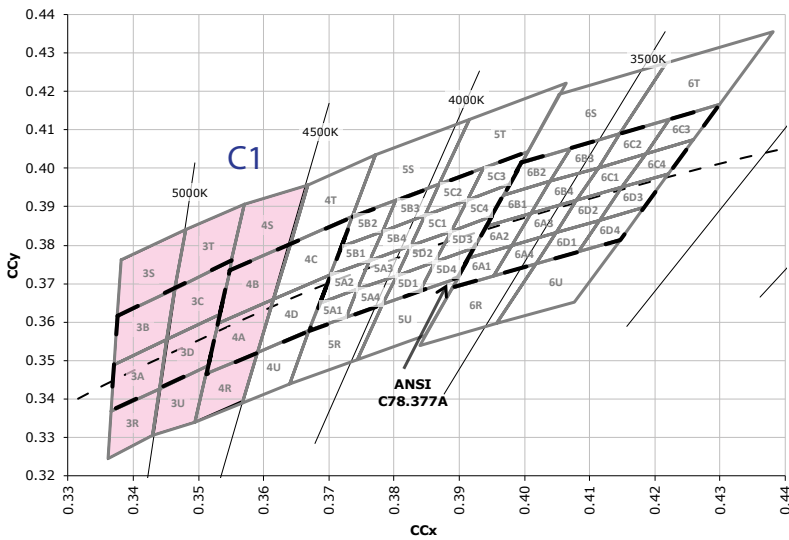

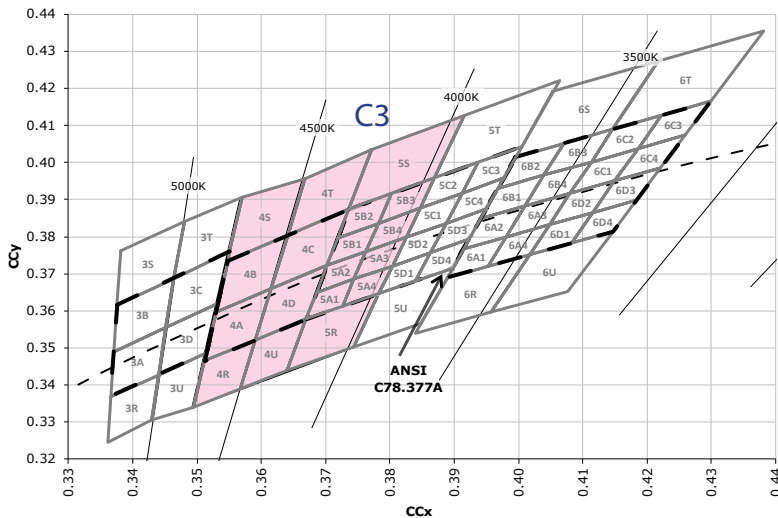
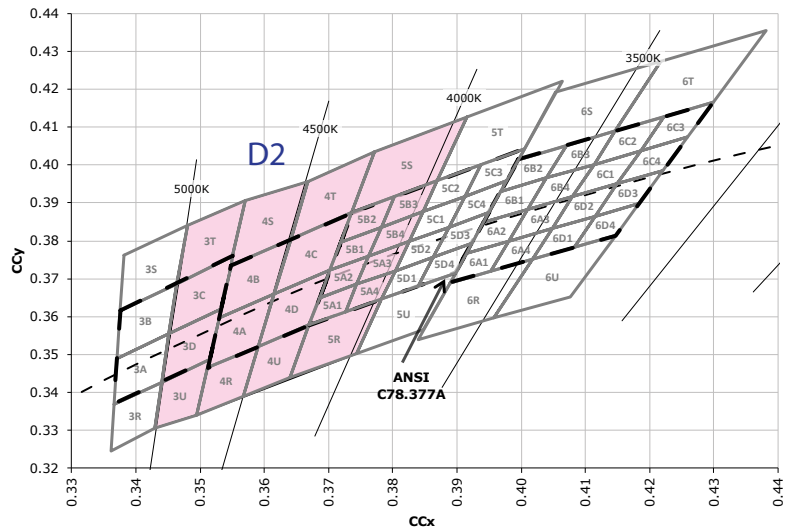
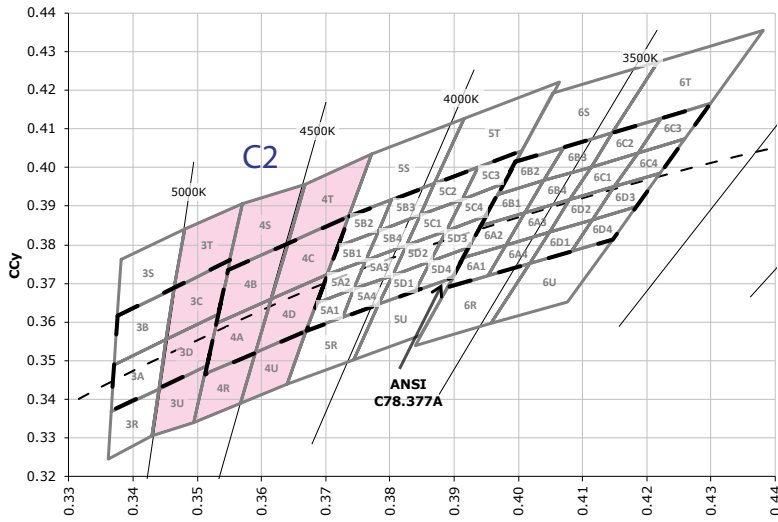

CREE'S STANDARD WARM AND NEUTRAL WHITE KITS PLOTTED ON ANSI STANDARD CHROMATICITY REGIONS

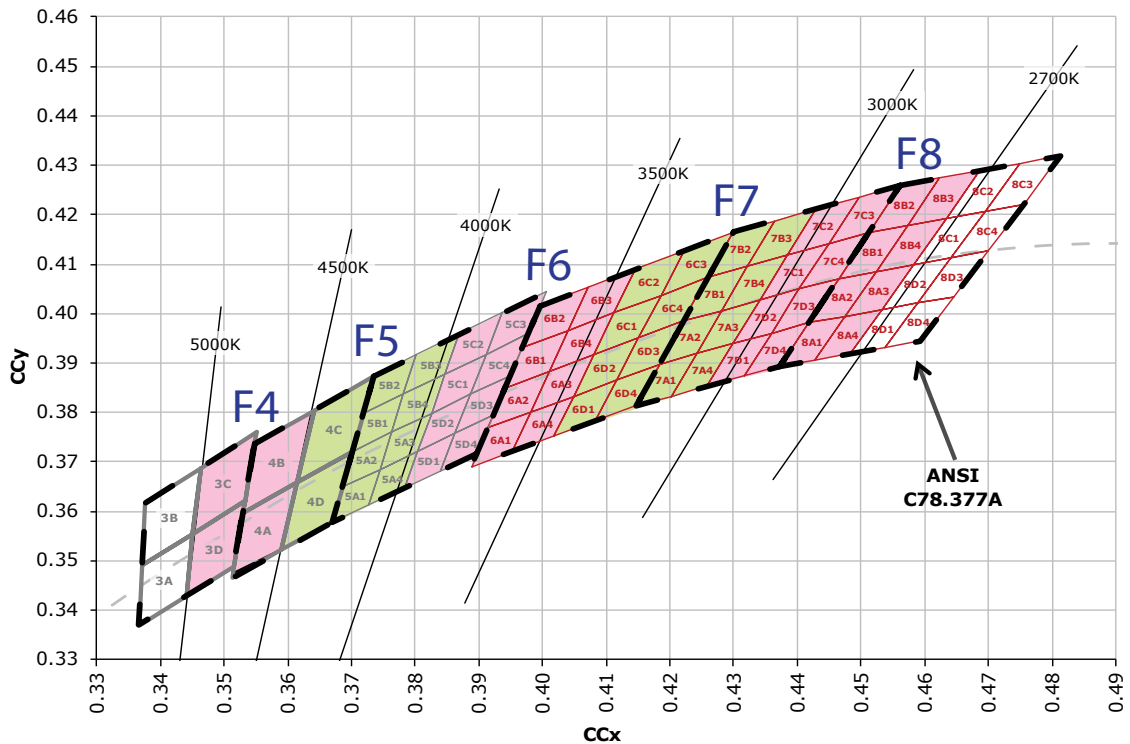
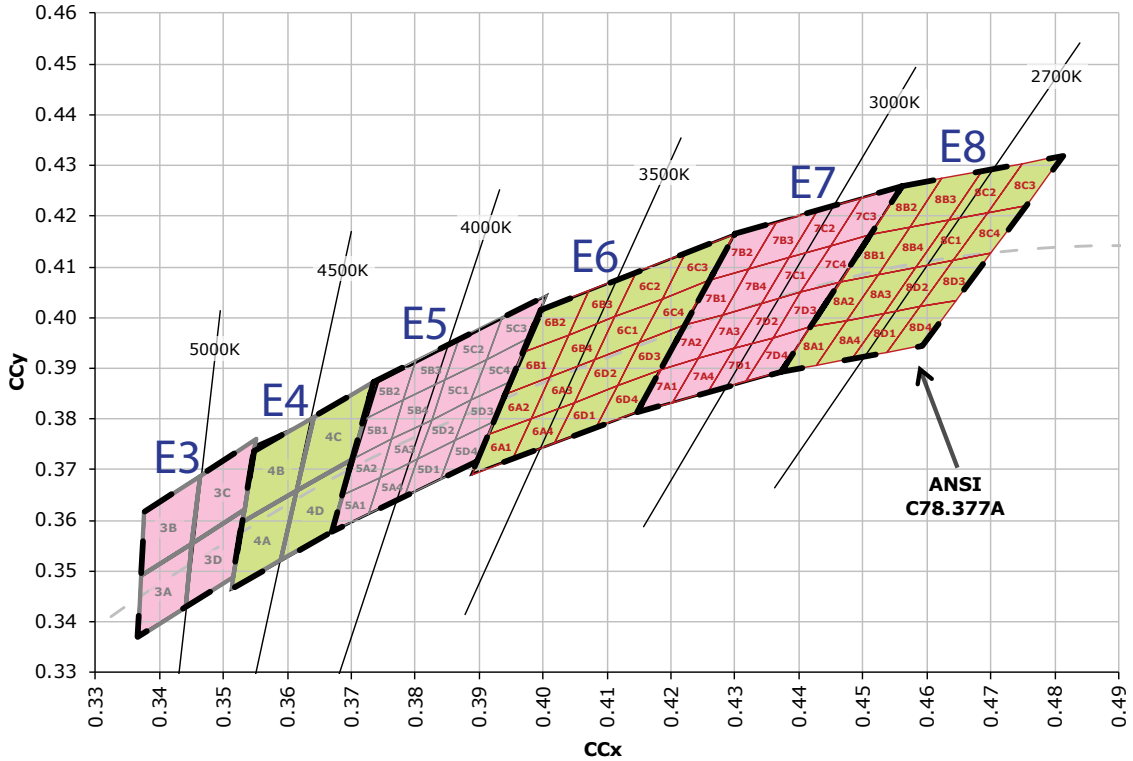

CREE'S STANDARD CHROMATICITY KITS

The following table provides the chromaticity bins associated with chromaticity kits, which are specified as part of the Order Code.

Color	Kit	Chromaticity Bins
Cool White	51	0A, 0B, 0C, 0D, 0R, 0S, 0T, 0U, 1A, 1B, 1C, 1D, 1R, 1S, 1T, 1U, 2A, 2B, 2C, 2D, 2R, 2S, 2T, 2U, 3A, 3B, 3R, 3S
	53	1A, 1B, 1C, 1D, 1R, 1S, 1T, 1U, 2A, 2B, 2C, 2D, 2R, 2S, 2T, 3A, 3B, 3S
	50	1A, 1B, 1C, 1D, 2A, 2B, 2C, 2D
Neutral White	E3	3A, 3B, 3C, 3D
	C1	3A, 3B, 3C, 3D, 3R, 3S, 3T, 3U, 4A, 4B, 4R, 4S
	F4	3C, 3D, 4A, 4B
	D1	3A, 3B, 3C, 3D, 3R, 3S, 3T, 3U, 4A, 4B, 4C, 4D, 4R, 4S, 4T, 4U
	E4	4A, 4B, 4C, 4D
	D2	3C, 3D, 3T, 3U, 4A, 4B, 4C, 4D, 4R, 4S, 4T, 4U, 5A1, 5A2, 5A3, 5A4, 5B1, 5B2, 5B3, 5B4, 5R, 5S
	C2	3C, 3D, 3T, 3U, 4A, 4B, 4C, 4D, 4R, 4S, 4T, 4U
	C3	4A, 4B, 4C, 4D, 4R, 4S, 4T, 4U, 5A1, 5A2, 5A3, 5A4, 5B1, 5B2, 5B3, 5B4, 5R, 5S
	F5	4C, 4D, 5A1, 5A2, 5A3, 5A4, 5B1, 5B2, 5B3, 5B4
Warm White	E5	5A1, 5A2, 5A3, 5A4, 5B1, 5B2, 5B3, 5B4, 5C1, 5C2, 5C3, 5C4, 5D1, 5D2, 5D3, 5D4
	F6	5C1, 5C2, 5C3, 5C4, 5D1, 5D2, 5D3, 5D4, 6A1, 6A2, 6A3, 6A4, 6B1, 6B2, 6B3, 6B4
	E6	6A1, 6A2, 6A3, 6A4, 6B1, 6B2, 6B3, 6B4, 6C1, 6C2, 6C3, 6C4, 6D1, 6D2, 6D3, 6D4
	F7	6C1, 6C2, 6C3, 6C4, 6D1, 6D2, 6D3, 6D4, 7A1, 7A2, 7A3, 7A4, 7B1, 7B2, 7B3, 7B4
	E7	7A1, 7A2, 7A3, 7A4, 7B1, 7B2, 7B3, 7B4, 7C1, 7C2, 7C3, 7C4, 7D1, 7D2, 7D3, 7D4
	F8	7C1, 7C2, 7C3, 7C4, 7D1, 7D2, 7D3, 7D4, 8A1, 8A2, 8A3, 8A4, 8B1, 8B2, 8B3, 8B4
	E8	8A1, 8A2, 8A3, 8A4, 8B1, 8B2, 8B3, 8B4, 8C1, 8C2, 8C3, 8C4, 8D1, 8D2, 8D3, 8D4

The following tables of order codes list flux minimums and chromaticity regions for the various categories of XLamp XB-D LEDs. For other flux and chromaticity combinations, contact Cree or an authorized distributor.

STANDARD ORDER CODES AND BINS (XB-D ANSI COOL WHITE, T_j = 85 °C)

XLamp XB-D Standard Kit Codes - White						
Chromaticity		Minimum Luminous Flux (lm) @ 350 mA*		Order Codes		
Kit	CCT	Code	Flux (lm)	No Minimum CRI	70 CRI Minimum	80 CRI Minimum
ANSI Cool White (5000 K – 8300 K)						
51	6200 K	R4	130	XBDAWT-00-0000-000000G51	XBDAWT-00-0000-00000BG51	
		R3	122	XBDAWT-00-0000-000000F51	XBDAWT-00-0000-00000BF51	XBDAWT-00-0000-00000HF51
		R2	114	XBDAWT-00-0000-000000E51	XBDAWT-00-0000-00000BE51	XBDAWT-00-0000-00000HE51
		Q5	107			XBDAWT-00-0000-00000HD51
53	6000 K	R4	130	XBDAWT-00-0000-000000G53	XBDAWT-00-0000-00000BG53	
		R3	122	XBDAWT-00-0000-000000F53	XBDAWT-00-0000-00000BF53	XBDAWT-00-0000-00000HF53
		R2	114	XBDAWT-00-0000-000000E53	XBDAWT-00-0000-00000BE53	XBDAWT-00-0000-00000HE53
		Q5	107			XBDAWT-00-0000-00000HD53
50	6200 K	R4	130	XBDAWT-00-0000-000000G50	XBDAWT-00-0000-00000BG50	
		R3	122	XBDAWT-00-0000-000000F50	XBDAWT-00-0000-00000BF50	XBDAWT-00-0000-00000HF50
		R2	114	XBDAWT-00-0000-000000E50	XBDAWT-00-0000-00000BE50	XBDAWT-00-0000-00000HE50
		Q5	107			XBDAWT-00-0000-00000HD50

STANDARD ORDER CODES AND BINS (XB-D NEUTRAL WHITE, T_j = 85 °C)

XLamp XB-D Standard Kit Codes - White							
Chromaticity		Minimum Luminous Flux (lm) @ 350 mA*		Order Codes			
Kit	CCT	Code	Flux (lm)	No CRI Minimum	70 CRI Minimum	Standard CRI	80 CRI Minimum
ANSI Neutral White (3700 K – 5000 K)							
E3	5000 K	R3	122	XBDAWT-00-0000-000000FE3	XBDAWT-00-0000-000000BFE3	XBDAWT-00-0000-000000LFE3	XBDAWT-00-0000-000000HFE3
		R2	114	XBDAWT-00-0000-000000EE3	XBDAWT-00-0000-000000BEE3	XBDAWT-00-0000-000000LEE3	XBDAWT-00-0000-000000HEE3
		Q5	107			XBDAWT-00-0000-000000LDE3	XBDAWT-00-0000-000000HDE3
C1	5000 K	R3	122	XBDAWT-00-0000-000000FC1	XBDAWT-00-0000-000000BFC1	XBDAWT-00-0000-000000LFC1	
		R2	114	XBDAWT-00-0000-000000EC1	XBDAWT-00-0000-000000BEC1	XBDAWT-00-0000-000000LEC1	
		Q5	107			XBDAWT-00-0000-000000LDC1	
F4	4750 K	R3	122	XBDAWT-00-0000-000000FF4	XBDAWT-00-0000-000000BFF4		
		R2	114	XBDAWT-00-0000-000000EF4	XBDAWT-00-0000-000000BEF4	XBDAWT-00-0000-000000LEF4	XBDAWT-00-0000-000000HEF4
		Q5	107	XBDAWT-00-0000-000000DF4	XBDAWT-00-0000-000000BDF4	XBDAWT-00-0000-000000LDF4	XBDAWT-00-0000-000000HDF4
		Q4	100			XBDAWT-00-0000-000000LCF4	XBDAWT-00-0000-000000HCF4
D1	4750 K	R3	122	XBDAWT-00-0000-000000FD1	XBDAWT-00-0000-000000BFD1	XBDAWT-00-0000-000000LFD1	
		R2	114	XBDAWT-00-0000-000000ED1	XBDAWT-00-0000-000000BED1	XBDAWT-00-0000-000000LED1	
		Q5	107			XBDAWT-00-0000-000000LDD1	
E4	4500 K	R3	122	XBDAWT-00-0000-000000FE4	XBDAWT-00-0000-000000BFE4		
		R2	114	XBDAWT-00-0000-000000EE4	XBDAWT-00-0000-000000BEE4	XBDAWT-00-0000-000000LEE4	XBDAWT-00-0000-000000HEE4
		Q5	107	XBDAWT-00-0000-000000DE4	XBDAWT-00-0000-000000BDE4	XBDAWT-00-0000-000000LDE4	XBDAWT-00-0000-000000HDE4
		Q4	100			XBDAWT-00-0000-000000LCE4	XBDAWT-00-0000-000000HCE4
D2	4500 K	R3	122	XBDAWT-00-0000-000000FD2	XBDAWT-00-0000-000000BFD2		
		R2	114	XBDAWT-00-0000-000000ED2	XBDAWT-00-0000-000000BED2	XBDAWT-00-0000-000000LED2	
		Q5	107	XBDAWT-00-0000-000000DD2	XBDAWT-00-0000-000000BDD2	XBDAWT-00-0000-000000LDD2	
		Q4	100			XBDAWT-00-0000-000000LCD2	
C2	4500 K	R3	122	XBDAWT-00-0000-000000FC2	XBDAWT-00-0000-000000BFC2	XBDAWT-00-0000-000000LFC2	
		R2	114	XBDAWT-00-0000-000000EC2	XBDAWT-00-0000-000000BEC2	XBDAWT-00-0000-000000LEC2	
		Q5	107			XBDAWT-00-0000-000000LDC2	
C3	4300 K	R3	122	XBDAWT-00-0000-000000FC3	XBDAWT-00-0000-000000BFC3	XBDAWT-00-0000-000000LFC3	
		R2	114	XBDAWT-00-0000-000000EC3	XBDAWT-00-0000-000000BEC3	XBDAWT-00-0000-000000LEC3	
		Q5	107			XBDAWT-00-0000-000000LDC3	
F5	4250 K	R2	114	XBDAWT-00-0000-000000EF5	XBDAWT-00-0000-000000BEF5		
		Q5	107	XBDAWT-00-0000-000000DF5	XBDAWT-00-0000-000000BDF5	XBDAWT-00-0000-000000LDF5	XBDAWT-00-0000-000000HDF5
		Q4	100	XBDAWT-00-0000-000000CF5	XBDAWT-00-0000-000000BCF5	XBDAWT-00-0000-000000LCF5	XBDAWT-00-0000-000000HCF5
		Q3	93.9			XBDAWT-00-0000-000000LBF5	XBDAWT-00-0000-000000HBF5
E5	4000 K	R2	114	XBDAWT-00-0000-000000EE5	XBDAWT-00-0000-000000BEE5		
		Q5	107	XBDAWT-00-0000-000000DE5	XBDAWT-00-0000-000000BDE5	XBDAWT-00-0000-000000LDE5	XBDAWT-00-0000-000000HDE5
		Q4	100	XBDAWT-00-0000-000000CE5	XBDAWT-00-0000-000000BCE5	XBDAWT-00-0000-000000LCE5	XBDAWT-00-0000-000000HCE5
		Q3	93.9			XBDAWT-00-0000-000000LBE5	XBDAWT-00-0000-000000HBE5

• Typical (Standard) CRI for Neutral White, 3700 K - 5000K CCT is 75

* Cree XLamp XB Family order codes specify only a minimum flux bin and not a maximum. Cree may ship reels in flux bins higher than the minimum specified by the order code

STANDARD ORDER CODES AND BINS (XB-D WARM WHITE, $T_j = 85\text{ }^\circ\text{C}$)

XLamp XB-D Standard Kit Codes - White									
Chromaticity		Minimum Luminous Flux (lm) @ 350 mA*		Order Codes: XBD AWT-00- (+ extensions below)					
Kit	CCT	Code	Flux (lm)	No CRI Minimum	70 CRI Minimum	Standard CRI	80 CRI Minimum	85 CRI Minimum	90 CRI Minimum
ANSI Warm White (2700 K - 3750 K)									
F6	3750 K	Q5	107	0000-00000LDF6	0000-00000BDF6	0000-00000LDF6	0000-00000HDF6		
		Q4	100	0000-000000CF6	0000-00000BCF6	0000-00000LCF6	0000-00000HCF6		
		Q3	93.9	0000-000000BF6	0000-00000BBF6	0000-00000LBF6	0000-00000HBF6		
E6	3500 K	Q5	107	0000-000000DE6	0000-00000BDE6	0000-00000LDE6	0000-00000HDE6		
		Q4	100	0000-000000CE6	0000-00000BCE6	0000-00000LCE6	0000-00000HCE6		
		Q3	93.9	0000-000000BE6	0000-00000BBE6	0000-00000LBE6	0000-00000HBE6		
F7	3250 K	Q4	100	0000-000000CF7	0000-00000BCF7	0000-00000LCF7	0000-00000HCF7		
		Q3	93.9	0000-000000BF7	0000-00000BBF7	0000-00000LBF7	0000-00000HBF7		
		Q2	87.4	0000-000000AF7	0000-00000BAF7	0000-00000LAF7	0000-00000HAF7		
		P4	80.6					0000-00000P9F7	0000-00000U9F7
		P3	73.9					0000-00000P8F7	0000-00000U8F7
		P2	67.2					0000-00000P7F7	0000-00000U7F7
E7	3000 K	Q4	100	0000-000000CE7	0000-00000BCE7	0000-00000LCE7	0000-00000HCE7		
		Q3	93.9	0000-000000BE7	0000-00000BBE7	0000-00000LBE7	0000-00000HBE7		
		Q2	87.4	0000-000000AE7	0000-00000BAE7	0000-00000LAE7	0000-00000HAE7		
		P4	80.6					0000-00000P9E7	0000-00000U9E7
		P3	73.9					0000-00000P8E7	0000-00000U8E7
		P2	67.2					0000-00000P7E7	0000-00000U7E7
F8	2850 K	Q3	93.9	0000-000000BF8	0000-00000BBF8	0000-00000LBF8	0000-00000HBF8		
		Q2	87.4	0000-000000AF8	0000-00000BAF8	0000-00000LAF8	0000-00000HAF8		
		P4	80.6	0000-0000009F8	0000-00000B9F8	0000-00000L9F8	0000-00000H9F8		
		P3	73.9					0000-00000P8E8	0000-00000U8E8
		P2	67.2					0000-00000P7E8	0000-00000U7E8
E8	2700 K	Q3	93.9	0000-000000BE8	0000-00000BBE8	0000-00000LBE8	0000-00000HBE8		
		Q2	87.4	0000-000000AE8	0000-00000BAE8	0000-00000LAE8	0000-00000HAE8		
		P4	80.6	0000-0000009E8	0000-00000B9E8	0000-00000L9E8	0000-00000H9E8		
		P3	73.9					0000-00000P8E8	0000-00000U8E8
		P2	67.2					0000-00000P7E8	0000-00000U7E8

• Typical (Standard) CRI for Warm White, 2600 K - 3700 K CCT is 80.

* Cree XLamp XB Family order codes specify only a minimum flux bin and not a maximum. Cree may ship reels in flux bins higher than the minimum specified by the order code

STANDARD ORDER CODES AND BINS (XB-D COLOR, T_j = 25 °C)

XLamp XB-D Standard Kit Codes - Royal Blue				
Kit	Dominant Wavelength (nm)	Minimum Rdiant Flux (mW) @ 350 mA*		Order Codes
		Code	Flux (mW)	
01	450 - 465	35	575	XBDROY-00-0000-000000P01
		34	550	XBDROY-00-0000-000000N01
		33	525	XBDROY-00-0000-000000M01
		32	500	XBDROY-00-0000-000000L01
		31	475	XBDROY-00-0000-000000K01
		30	450	XBDROY-00-0000-000000J01
02	450 - 460	35	575	XBDROY-00-0000-000000P02
		34	550	XBDROY-00-0000-000000N02
		33	525	XBDROY-00-0000-000000M02
		32	500	XBDROY-00-0000-000000L02
		31	475	XBDROY-00-0000-000000K02
		30	450	XBDROY-00-0000-000000J02
03	455 - 465	34	550	XBDROY-00-0000-000000N03
		33	525	XBDROY-00-0000-000000M03
		32	500	XBDROY-00-0000-000000L03
		31	475	XBDROY-00-0000-000000K03
		30	450	XBDROY-00-0000-000000J03
04	450 - 455	35	575	XBDROY-00-0000-000000NP04
		34	550	XBDROY-00-0000-000000N04
		33	525	XBDROY-00-0000-000000M04
		32	500	XBDROY-00-0000-000000L04
		31	475	XBDROY-00-0000-000000K04
		30	450	XBDROY-00-0000-000000J04
05	455 - 460	34	550	XBDROY-00-0000-000000N05
		33	525	XBDROY-00-0000-000000M05
		32	500	XBDROY-00-0000-000000L05
		31	475	XBDROY-00-0000-000000K05
		30	450	XBDROY-00-0000-000000J05
06	460 - 465	33	525	XBDROY-00-0000-000000M06
		32	500	XBDROY-00-0000-000000L06
		31	475	XBDROY-00-0000-000000K06
		30	450	XBDROY-00-0000-000000J06
07	452.5 - 457.5	34	550	XBDROY-00-0000-000000N07
		33	525	XBDROY-00-0000-000000M07
		32	500	XBDROY-00-0000-000000L07
		31	475	XBDROY-00-0000-000000K07
		30	450	XBDROY-00-0000-000000J07
08	457.5 - 462.5	33	525	XBDROY-00-0000-000000M08
		32	500	XBDROY-00-0000-000000L08
		31	475	XBDROY-00-0000-000000K08
		30	450	XBDROY-00-0000-000000J08

STANDARD ORDER CODES AND BINS (XB-D COLOR, T_j = 25 °C), CONTINUED

XLamp XB-D Standard Kit Codes - Royal Blue				
Kit	Dominant Wavelength (nm)	Minimum Rdiant Flux (mW) @ 350 mA*		Order Codes
		Code	Flux (mW)	
09	452.5 - 462.5	34	550	XBDROY-00-0000-000000N09
		33	525	XBDROY-00-0000-000000M09
		32	500	XBDROY-00-0000-000000L09
		31	475	XBDROY-00-0000-000000K09
		30	450	XBDROY-00-0000-000000J09

XLamp XB-D Standard Kit Codes - Blue				
Kit	Dominant Wavelength (nm)	Minimum Luminous Flux (lm) @ 350 mA*		Order Codes
		Code	Flux (lm)	
01	465 - 485	M2	39.8	XBDBLU-00-0000-000000Z01
		K3	35.2	XBDBLU-00-0000-000000Z01
		K2	30.6	XBDBLU-00-0000-000000Y01
02	465 - 480	M2	39.8	XBDBLU-00-0000-000000Z02
		K3	35.2	XBDBLU-00-0000-000000Z02
		K2	30.6	XBDBLU-00-0000-000000Y02
05	470 - 480	M2	39.8	XBDBLU-00-0000-000000Z05
		K3	35.2	XBDBLU-00-0000-000000Z05
		K2	30.6	XBDBLU-00-0000-000000Y05

XLamp XB-D Standard Kit Codes - Green				
Kit	Dominant Wavelength (nm)	Minimum Luminous Flux (lm) @ 350 mA*		Order Codes
		Code	Flux (lm)	
01	520 - 535	Q5	107	XBDGRN-00-0000-000000D01
		Q4	100	XBDGRN-00-0000-000000C01
		Q3	93.9	XBDGRN-00-0000-000000B01
		Q2	87.4	XBDGRN-00-0000-000000A01
02	520 - 530	Q5	107	XBDGRN-00-0000-000000D02
		Q4	100	XBDGRN-00-0000-000000C02
		Q3	93.9	XBDGRN-00-0000-000000B02
		Q2	87.4	XBDGRN-00-0000-000000A02
03	525 - 535	Q5	107	XBDGRN-00-0000-000000D03
		Q4	100	XBDGRN-00-0000-000000C03
		Q3	93.9	XBDGRN-00-0000-000000B03
		Q2	87.4	XBDGRN-00-0000-000000A03

STANDARD ORDER CODES AND BINS (XB-D COLOR, T_j = 25 °C), CONTINUED

XLamp XB-D Standard Kit Codes - Red				
Red		Minimum Luminous Flux (lm) @ 350 mA*		Order Codes
Kit	Dominant Wavelength (nm)	Code	Flux (lm)	
01	620 - 630	P3	73.9	XBDRED-00-0000-000000801
		P2	67.2	XBDRED-00-0000-000000701
		N4	62	XBDRED-00-0000-000000601
02	620 - 625	P3	73.9	XBDRED-00-0000-000000802
		P2	67.2	XBDRED-00-0000-000000702
		N4	62	XBDRED-00-0000-000000602

XLamp XB-D Standard Kit Codes - Red Orange				
Red Orange		Minimum Luminous Flux (lm) @ 350 mA*		Order Codes
Kit	Dominant Wavelength (nm)	Code	Flux (lm)	
01	610 - 620	Q3	93.9	XBDRDO-00-0000-000000B01
		Q2	87.4	XBDRDO-00-0000-000000A01
		P4	80.6	XBDRDO-00-0000-000000901
		P3	73.9	XBDRDO-00-0000-000000801
02	610 - 615	Q3	93.9	XBDRDO-00-0000-000000B02
		Q2	87.4	XBDRDO-00-0000-000000A02
		P4	80.6	XBDRDO-00-0000-000000902
		P3	73.9	XBDRDO-00-0000-000000802
03	615 - 620	Q3	93.9	XBDRDO-00-0000-000000B03
		Q2	87.4	XBDRDO-00-0000-000000A03
		P4	80.6	XBDRDO-00-0000-000000903
		P3	73.9	XBDRDO-00-0000-000000803