

TOSHIBA TRANSISTOR SILICON NPN TRIPLE DIFFUSED MESA TYPE

2SD2553

HORIZONTAL DEFLECTION OUTPUT FOR HIGH RESOLUTION DISPLAY, COLOR TV

HIGH SPEED SWITCHING APPLICATIONS

- High Voltage : $V_{CBO} = 1700\text{ V}$
- Low Saturation Voltage : $V_{CE(sat)} = 5\text{ V (Max.)}$
- High Speed : $t_f = 0.3\ \mu\text{s (Typ.)}$
- Built-in Damper Type
- Collector Metal (Fin) is Fully Covered with Mold Resin.

MAXIMUM RATINGS ($T_a = 25^\circ\text{C}$)

CHARACTERISTIC		SYMBOL	RATING	UNIT
Collector-Base Voltage		V_{CBO}	1700	V
Collector-Emitter Voltage		V_{CEO}	600	V
Emitter-Base Voltage		V_{EBO}	5	V
Collector Current	DC	I_C	8	A
	Pulse	I_{CP}	16	
Base Current		I_B	4	A
Collector Power Dissipation ($T_c = 25^\circ\text{C}$)		P_C	50	W
Junction Temperature		T_j	150	$^\circ\text{C}$
Storage Temperature Range		T_{stg}	-55~150	$^\circ\text{C}$

Unit in mm

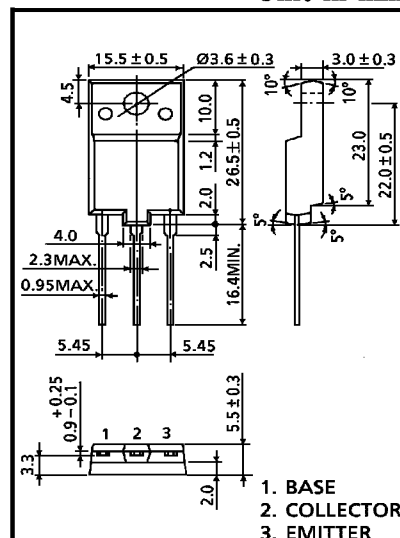

JEDEC	—
EIAJ	—
TOSHIBA	2-16E3A

Weight : 5.5 g (Typ.)

EQUIVALENT CIRCUIT

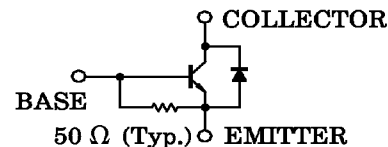

961001EAA1

- TOSHIBA is continually working to improve the quality and the reliability of its products. Nevertheless, semiconductor devices in general can malfunction or fail due to their inherent electrical sensitivity and vulnerability to physical stress. It is the responsibility of the buyer, when utilizing TOSHIBA products, to observe standards of safety, and to avoid situations in which a malfunction or failure of a TOSHIBA product could cause loss of human life, bodily injury or damage to property. In developing your designs, please ensure that TOSHIBA products are used within specified operating ranges as set forth in the most recent products specifications. Also, please keep in mind the precautions and conditions set forth in the TOSHIBA Semiconductor Reliability Handbook.
- The information contained herein is presented only as a guide for the applications of our products. No responsibility is assumed by TOSHIBA CORPORATION for any infringements of intellectual property or other rights of the third parties which may result from its use. No license is granted by implication or otherwise under any intellectual property or other rights of TOSHIBA CORPORATION or others.
- The information contained herein is subject to change without notice.

1999-09-02 1/4

ELECTRICAL CHARACTERISTICS (Ta = 25°C)

CHARACTERISTIC	SYMBOL	TEST CONDITION	MIN.	TYP.	MAX.	UNIT
Collector Cut-off Current	I_{CBO}	$V_{CB} = 1700\text{ V}, I_E = 0$	—	—	1	mA
Emitter Cut-off Current	I_{EBO}	$V_{EB} = 5\text{ V}, I_C = 0$	66	—	200	mA
Emitter-Base Breakdown Voltage	V_{EBO}	$I_E = 400\text{ mA}, I_C = 0$	5	—	—	V
DC Current Gain	$h_{FE(1)}$	$V_{CE} = 5\text{ V}, I_C = 1\text{ A}$	8	—	28	—
	$h_{FE(2)}$	$V_{CE} = 5\text{ V}, I_C = 6\text{ A}$	5	—	9	
Collector-Emitter Saturation Voltage	$V_{CE(sat)}$	$I_C = 6\text{ A}, I_B = 1.2\text{ A}$	—	—	5	V
Base-Emitter Saturation Voltage	$V_{BE(sat)}$	$I_C = 6\text{ A}, I_B = 1.2\text{ A}$	—	0.9	1.2	V
Forward Voltage (Damper Diode)	$-V_F$	$I_F = 8\text{ A}$	—	1.6	2.0	V
Transition Frequency	f_T	$V_{CE} = 10\text{ V}, I_C = 0.1\text{ A}$	—	2	—	MHz
Collector Output Capacitance	C_{ob}	$V_{CB} = 10\text{ V}, I_E = 0,$ $f = 1\text{ MHz}$	—	155	—	pF
Switching Time (Fig.1)	Storage Time	$I_{CP} = 6\text{ A}, I_{B1}(\text{end}) = 1.5\text{ A}$ $f_H = 15.75\text{ kHz}$	—	9	12	μs
	Fall Time		—	0.3	0.7	

Fig.1 Switching time test circuit

