

MATERIALS AND FINISHES:

BODY, JAM NUT: BRASS
FINISH: SEE TABLE

CENTER CONTACT: BERYLLIUM COPPER
PLATED GOLD

INSULATOR: TEFLON

LOCKWASHER: PHOSPHOR BRONZE
FINISH: SEE TABLE

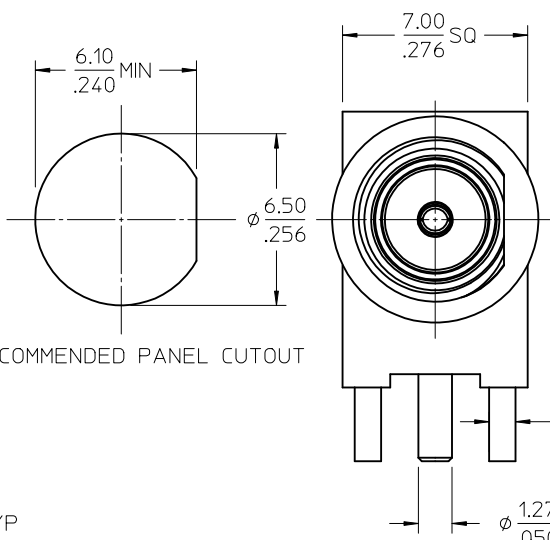

SMA JACK
INTERFACE

1/4-36 UNS-2A

1.00
.039 SQ
4 PLACES

1.27 REF
.050

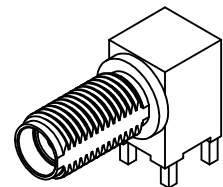
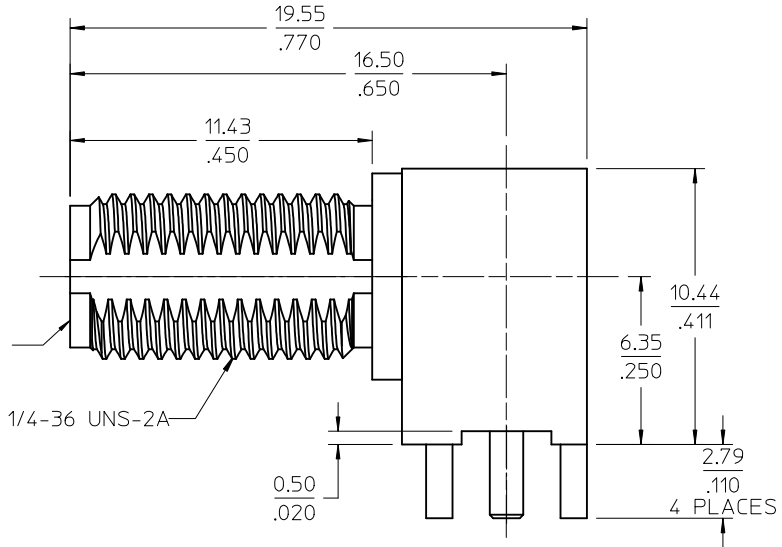

RECOMMENDED PANEL CUTOUT

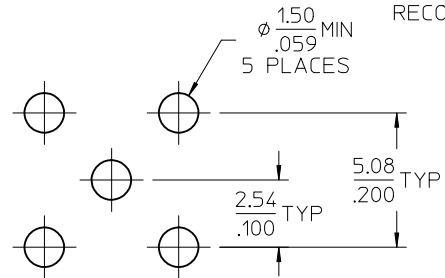

RECOMMENDED PCB LAYOUT

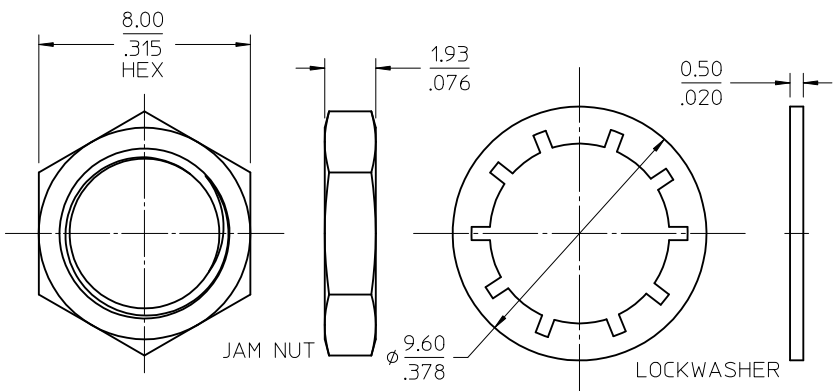

JAM NUT

LOCKWASHER

73251-2207	73251-2201 PACKAGED ONE PER BAG
73251-2206	SAME AS 73251-2201 EXCEPT COMMERCIAL CONTACT
73251-2205	SAME AS 73251-2200 EXCEPT COMMERCIAL CONTACT
73251-2204	GOLD FLASH/STANDARD TRAY W/O WASHER AND NUT
73251-2203	GOLD FLASH / STANDARD TRAY (54 CAVITY)
73251-2202	73251-2201 PACKAGED IN SMALL TRAY (20 CAVITY)
73251-2201	GOLD / STANDARD TRAY
73251-2200	NICKEL / STANDARD TRAY
PART NO.	PLATING (BODY, NUT, LOCKWASHER) AND PACKAGING

PS-89675-3460	ELECTRO/MECH PERFORM.
SPECIFICATION	DESCRIPTION

CHG: ADDED -2207 PS WAS PS-73598-0460	EC NO: URF2011-0623	DRWN: JWIENER 2011/04/25	CHKD: SSS 2011/04/25	APPR: JWIENER 2011/04/26
REV	DESCRIPTION	QUALITY SYMBOLS		
D9		▽=0		
		▽=0		

GENERAL TOLERANCES (UNLESS SPECIFIED)	DIMENSION STYLE	SCALE	DESIGN UNITS	THIRD ANGLE PROJECTION
	MM/IN		METRIC	
4 PLACES ± .005	mm	DRAWN BY	DATE	TITLE
3 PLACES ± .005	INCH	CLAIRE LEE	2003/08/29	SMA JACK, R/A PCB 50 OHM
2 PLACES ± .005		CHECKED BY	DATE	SMA-J/RA/PCB
1 PLACE ± .005		PAT	2003/08/29	EWR-2144
ANGULAR ± 2°		APPROVED BY	DATE	
DRAFT WHERE APPLICABLE MUST REMAIN WITHIN DIMENSIONS	MATERIAL NO.	DOCUMENT NO.	SHEET NO.	
	SEE TABLE	SD-73251-220	1 OF 1	
	SIZE	THIS DRAWING CONTAINS INFORMATION THAT IS PROPRIETARY TO MOLEX INCORPORATED AND SHOULD NOT BE USED WITHOUT WRITTEN PERMISSION		
	C			

molex MOLEX INCORPORATED