



SMBus/I²C[®]-Compatible, 10-Bit Digital Temperature Sensors in SOT-23

AD7414/AD7415

FEATURES

10-Bit Temperature-to-Digital Converter
Temperature Range: -40°C to +85°C
Accuracy of ±2°C
SMBus/I²C-Compatible Serial Interface
3 μA Power-Down Current
Temperature Conversion Time: 29 μs Typ
Space-Saving 6-Lead (AD7414) and 5-Lead (AD7415) SOT-23 Packages
Pin-Selectable Addressing via AS
Overtemperature Indicator (AD7414 Only)
SMBus Alert Function (AD7414 Only)
Four Versions Allow Eight I²C Addresses (AD7414)
Two Versions Allow Six I²C Addresses (AD7415)

APPLICATIONS

Hard Disk Drives
Personal Computers
Electronic Test Equipment
Office Equipment
Domestic Appliances
Process Control
Cellular Phones

GENERAL DESCRIPTION

The AD7414/AD7415 is a complete temperature monitoring system in 6-lead and 5-lead SOT-23 packages. It contains a bandgap temperature sensor and 10-bit ADC to monitor and digitize the temperature reading to a resolution of 0.25°C.

The AD7414/AD7415 provides a 2-wire serial interface that is compatible with SMBus and I²C interfaces. The part comes in four versions, AD7414/AD7415-0, AD7414/AD7415-1, AD7414-2 and the AD7414-3. The AD7414/AD7415-0 and AD7414/AD7415-1 versions allow for a choice of three different SMBus addresses for each version. All four AD7414 versions give the possibility of eight different I²C addresses while the two AD7415 versions allow up to six I²C addresses to be used.

The AD7414/AD7415's 2.7 V supply voltage, low supply current, serial interface, and small package size, make it ideal for a variety of applications, including personal computers, office equipment, cellular phones, and domestic appliances.

In the AD7414, on-chip registers can be programmed with high and low temperature limits, and an open drain Over-Temperature Indicator output (ALERT), which becomes active when a programmed limit is exceeded. A configuration register allows programming of the sense of the ALERT output (active high or active low). This output can be used as an interrupt or as an SMBus alert.

I²C is a registered trademark of Philips Corporation.

REV. 0

Information furnished by Analog Devices is believed to be accurate and reliable. However, no responsibility is assumed by Analog Devices for its use, nor for any infringements of patents or other rights of third parties that may result from its use. No license is granted by implication or otherwise under any patent or patent rights of Analog Devices.

FUNCTIONAL BLOCK DIAGRAM

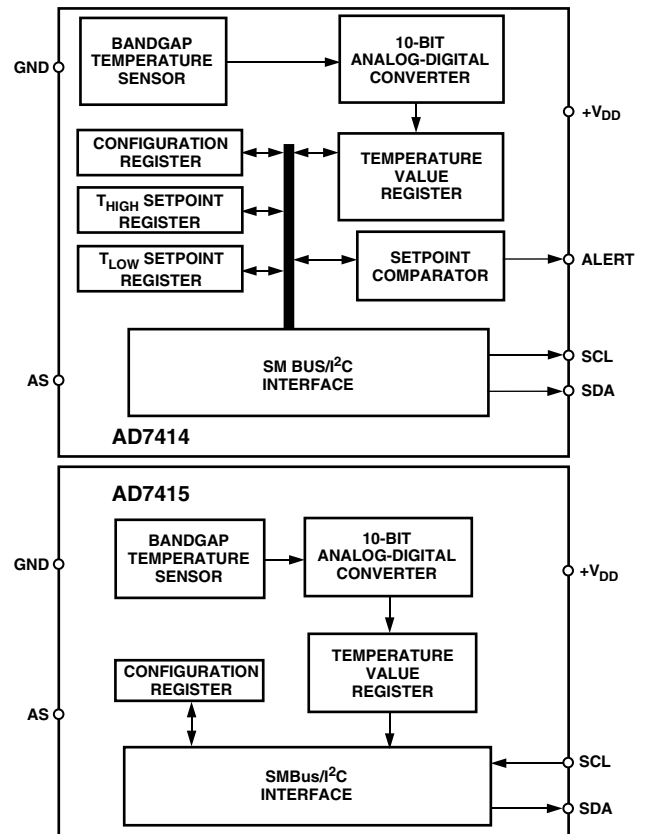

PRODUCT HIGHLIGHTS

1. The AD7414/AD7415 has an on-chip temperature sensor that allows an accurate measurement of the ambient temperature to be made. It is capable of ±2°C temperature accuracy.
2. SMBus/I²C-Compatible Serial Interface with pin-selectable choice of three addresses per version of the AD7414/AD7415, eight address options in total for the AD7414 and six in total for the AD7415.
3. Supply voltage of 2.7 V to 5.5 V.
4. Space-saving 5-lead and 6-lead SOT-23 packages.
5. 10-bit temperature reading to 0.25°C resolution.
6. The AD7414 has an Over Temperature Indicator which can be software disabled. Used as an interrupt of SMBus alert.
7. One-shot and automatic temperature conversion rates.

AD7414/AD7415—SPECIFICATIONS¹ (T_A = T_{MIN} to T_{MAX}, V_{DD} = 2.7 V to 5.5 V, unless otherwise noted.)

Parameter	A Version	Unit	Test Conditions/Comments
TEMPERATURE SENSOR AND ADC			
Accuracy ²	±2.0 ±3.0	°C max °C max	V _{DD} = 3 V V _{DD} = 5.5 V
Resolution	10	Bits	
Update Rate, t _R	800	ms typ	
Temperature Conversion Time	25	µs typ	
POWER SUPPLIES			
Supply Current ³			
Peak Supply Current ⁴	1.2	mA typ	Peak current during conversion.
Inactive Serial Bus ⁵			
Normal Mode @ 3 V	169	µA typ	Supply current with serial bus inactive. Part not converting and D7 of Configuration Register = 0.
Normal Mode @ 5 V	188	µA typ	
Active Serial Bus ⁶			
Normal Mode @ 3 V	180	µA typ	Supply current with serial bus active. Part not converting and D7 of Configuration Register = 0. D7 of Configuration Register = 1. Typical values are 0.04 µA at 3 V and 0.5 µA at 5 V.
Normal Mode @ 5 V	214	µA typ	
Shutdown Mode	3	µA max	
DIGITAL INPUT			
Input High Voltage, V _{IH}	2.4	V min	V _{IN} = 0 V to V _{DD} All Digital Inputs
Input Low Voltage, V _{IL}	0.8	V max	
Input Current, I _{IN}	±1	µA max	
Input Capacitance, C _{IN}	10	pF max	
DIGITAL OUTPUT			
Output High Voltage, V _{OH}	2.4	V min	I _{OL} = 1.6 mA V _{OH} = 5 V T _{yp} = 3 pF I _{OUT} = 4 mA
Output Low Voltage, V _{OL}	0.4	V max	
Output High Current, I _{OH}	1	mA max	
Output Capacitance, C _{OUT}	10	pF max	
ALERT Output Saturation Voltage	0.8	V max	
AC ELECTRICAL CHARACTERISTICS^{7, 8}			
Serial Clock Period, t ₁	2.5	µs min	See Figure 1
Data In Setup Time to SCL High, t ₂	50	ns min	See Figure 1
Data Out Stable after SCL Low, t ₃	0	ns min	See Figure 1
SDA Low Setup Time to SCL Low (Start Condition), t ₄	50	ns min	See Figure 1
SDA High Hold Time after SCL High (Stop Condition), t ₅	50	ns min	See Figure 1
SDA and SCL Fall Time, t ₆	90	ns max	See Figure 1
Power-Up Time	4	µs typ	

NOTES

¹Temperature range as follows: A Version = -40°C to +85°C.

²Accuracy specifications apply only to voltages listed under Test Conditions. See Temperature Accuracy vs. Supply section for typical accuracy performance over the full V_{DD} supply range.

³These current values can be used to determine average power consumption at different one-shot conversion rates. Average power consumption at the automatic conversion rate of 1.25 kHz is 940 µW.

⁴This peak supply current is required for 29 µs (the conversion time plus power-up time) out of every 800 µs (the conversion rate).

⁵These current values are derived by not issuing a stop condition at the end of a write or read, thus preventing the part from going into a conversion.

⁶The current is derived assuming a 400 kHz serial clock being active continuously.

⁷The SDA and SCL timing is measured with the input filters turned on so as to meet the Fast-Mode I²C specification. Switching off the input filters improves the transfer rate but has a negative effect on the EMC behavior of the part.

⁸Guaranteed by design. Not tested in production.

Specifications subject to change without notice.

PIN FUNCTION DESCRIPTIONS

Mnemonic	Description
AS	Logic Input. Address Select Input which selects one of three I ² C addresses for the AD7414/AD7415 (See Table I).
GND	Analog and Digital Ground.
V _{DD}	Positive Supply Voltage, 2.7 V to 5.5 V.
SDA	Digital I/O. Serial Bus Bidirectional Data. Open-Drain Output.
ALERT	AD7414 Digital Output. Over Temperature Indicator, becomes active when temperature exceeds T _{HIGH} . Open-Drain output.
SCL	Digital Input. Serial Bus Clock.

ABSOLUTE MAXIMUM RATINGS*

V _{DD} to GND	−0.3 V to +7 V
SDA Input Voltage to GND	−0.3 V to +7 V
SDA Output Voltage to GND	−0.3 V to +7 V
SCL Input Voltage to GND	−0.3 V to +7 V
ALERT Output Voltage to GND	−0.3 V to +7 V
Operating Temperature Range	−40°C to +85°C
Storage Temperature Range	−65°C to +150°C
Junction Temperature	150°C
SOT-23, Power Dissipation	450 mW
θ _{JA} Thermal Impedance	240°C/W
Lead Temperature, Soldering	
Vapor Phase (60 sec)	215°C
Infrared (15 sec)	220°C

*Stresses above those listed under Absolute Maximum Ratings may cause permanent damage to the device. This is a stress rating only; functional operation of the device at these or any other conditions above those indicated in the operational section of this specification is not implied. Exposure to absolute maximum rating conditions for extended periods may affect device reliability.

PIN CONFIGURATIONS

SOT-23

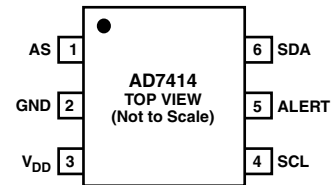

μSOIC

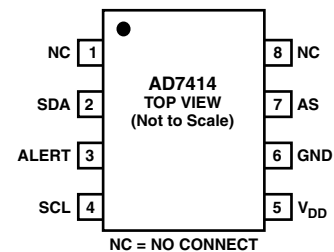

SOT-23

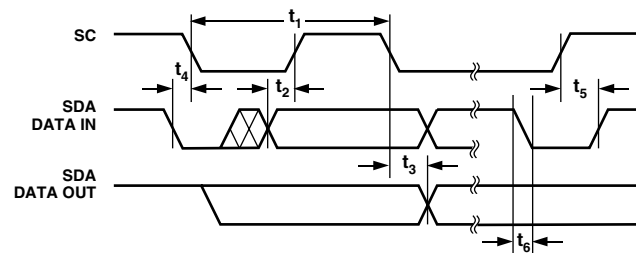
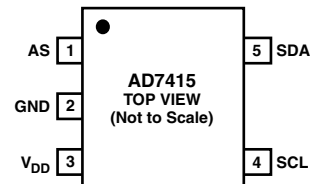

Figure 1. Diagram for Serial Bus Timing

CAUTION

ESD (electrostatic discharge) sensitive device. Electrostatic charges as high as 4000 V readily accumulate on the human body and test equipment and can discharge without detection. Although the AD7414/AD7415 features proprietary ESD protection circuitry, permanent damage may occur on devices subjected to high-energy electrostatic discharges. Therefore, proper ESD precautions are recommended to avoid performance degradation or loss of functionality.



AD7414/AD7415

ORDERING GUIDE

Model	Temperature Range	Temperature Error @ 3 V	Package Options	Package Description	Branding Information	Min Qtys/ Reel
AD7414ART-0REEL7	-40°C to +85°C	±2°C	RT-6	6-Lead SOT-23	CHA ¹	3000
AD7414ART-0REEL	-40°C to +85°C	±2°C	RT-6	6-Lead SOT-23	CHA ¹	10000
AD7414ART-0500RL7	-40°C to +85°C	±2°C	RT-6	6-Lead SOT-23	CHA ¹	500
AD7414ARM-0REEL7	-40°C to +85°C	±2°C	RM-8	8-Lead Mini_SO	CHA ¹	3000
AD7414ARM-0REEL	-40°C to +85°C	±2°C	RM-8	8-Lead Mini_SO	CHA ¹	10000
AD7414ARM-0 ²	-40°C to +85°C	±2°C	RM-8	8-Lead Mini_SO	CHA ¹	
AD7414ART-1REEL7	-40°C to +85°C	±2°C	RT-6	6-Lead SOT-23	CHB ³	3000
AD7414ART-1REEL	-40°C to +85°C	±2°C	RT-6	6-Lead SOT-23	CHB ³	10000
AD7414ART-1500RL7	-40°C to +85°C	±2°C	RT-6	6-Lead SOT-23	CHB ³	500
AD7414ARM-1REEL7	-40°C to +85°C	±2°C	RM-8	8-Lead Mini_SO	CHB ³	3000
AD7414ARM-1REEL	-40°C to +85°C	±2°C	RM-8	8-Lead Mini_SO	CHB ³	10000
AD7414ARM-1 ²	-40°C to +85°C	±2°C	RM-8	8-Lead Mini_SO	CHB ³	
AD7414ART-2REEL7	-40°C to +85°C	±2°C	RT-6	6-Lead SOT-23	CHC ³	3000
AD7414ART-2REEL	-40°C to +85°C	±2°C	RT-6	6-Lead SOT-23	CHC ³	10000
AD7414ART-3REEL7	-40°C to +85°C	±2°C	RT-6	6-Lead SOT-23	CHD ³	3000
AD7414ART-3REEL	-40°C to +85°C	±2°C	RT-6	6-Lead SOT-23	CHD ³	10000
AD7415ART-0REEL7	-40°C to +85°C	±2°C	RT-5	5-Lead SOT-23	CGA ¹	3000
AD7415ART-0REEL	-40°C to +85°C	±2°C	RT-5	5-Lead SOT-23	CGA ¹	10000
AD7415ART-0500RL7	-40°C to +85°C	±2°C	RT-5	5-Lead SOT-23	CGA ¹	500
AD7415ART-1REEL7	-40°C to +85°C	±2°C	RT-5	5-Lead SOT-23	CGB ³	3000
AD7415ART-1REEL	-40°C to +85°C	±2°C	RT-5	5-Lead SOT-23	CGB ³	10000
AD7415ART-1500RL7	-40°C to +85°C	±2°C	RT-5	5-Lead SOT-23	CGB ³	500

NOTES

¹Available to order.

²This model shipped in tubes.

³Contact factory for availability.

Table I. I²C Address Selection

Part Number	AS Pin	I ² C Address
AD7414-0	Float	1001 000
AD7414-0	GND	1001 001
AD7414-0	V _{DD}	1001 010
AD7414-1	Float	1001 100
AD7414-1	GND	1001 101
AD7414-1	V _{DD}	1001 110
AD7414-2	N/A	1001 011
AD7414-3	N/A	1001 111
AD7415-0	Float	1001 000
AD7415-0	GND	1001 001
AD7415-0	V _{DD}	1001 010
AD7415-1	Float	1001 100
AD7415-1	GND	1001 101
AD7415-1	V _{DD}	1001 110

CIRCUIT INFORMATION

The AD7414/AD7415 is a stand-alone digital temperature sensor. The on-chip temperature sensor allows an accurate measurement of the ambient device temperature to be made. The 10-bit A/D converter converts the temperature measured into a two's complement format for storage in the Temperature Register. The A/D converter is made up of a conventional successive-approximation converter based around a capacitor DAC. The serial interface is I²C and SMBus compatible. The AD7414 AD7415 requires a 2.7 V to 5.5 V power supply. The temperature sensor has a working measurement range of -40°C to +85°C.

FUNCTIONAL DESCRIPTION

Temperature measurement is initiated by a couple of methods. The first uses an internal clock countdown of 800 ms, and a conversion is performed. The internal oscillator is the only circuit that is powered up between conversions and once it times out, every 800 ms, a wake-up signal is sent to power up the rest of the circuitry. A monostable is activated at the beginning of the wake-up signal to ensure that sufficient time is given to the power-up process. The monostable typically takes 4 μs to time out. It then takes typically 25 μs for each conversion to be completed. The new temperature value is loaded into the Temperature Value Register and ready for reading by the I²C interface.

A temperature measurement is also initiated every time the one-shot method is used. This method requires the user to write to the One-Shot Bit in the Configuration Register when a temperature measurement is needed. Setting the One-Shot Bit to a 1 will start a temperature conversion directly after the write operation. The track/hold goes into hold approximately 4 μs (monostable timeout) after the STOP condition and a conversion is then initiated. Typically 25 μs later, the conversion is complete and the Temperature Value Register is loaded with a new temperature value.

The measurement modes are compared with a high temperature limit, stored in an 8-bit read/write register. This is applicable only to the AD7414 as the AD7415 does not have an ALERT pin and subsequently does not have an over-temperature monitoring function. If the measurement is greater than the high limit, the ALERT pin is activated (if it has already been enabled in the Configuration Register). There are two ways to deactivate the ALERT pin again, firstly when the Alert Reset bit in the Configuration register is set to a 1 by a write operation; and secondly when the temperature measured is less than the value in the T_{LOW} Register. This ALERT pin is compatible with the SMBus SMBALERT option.

Configuration functions consist of:

- Switching between normal operation and full power-down.
- Enabling or disabling the SCL and SDA filters.
- Enabling or disabling the ALERT function.
- Setting ALERT pin polarity.

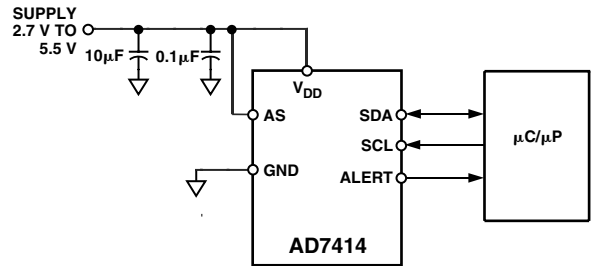

Figure 2. Typical Connection Diagram

MEASUREMENT TECHNIQUE

A common method of measuring temperature is to exploit the negative temperature coefficient of a diode, or the base-emitter voltage of a transistor, operated at constant current. Unfortunately, this technique requires calibration to null out the effect of the absolute value of V_{BE}, which varies from device to device.

The technique used in the AD7414/AD7415 is to measure the change in V_{BE} when the device is operated at two different currents.

This is given by:

$$\Delta V_{BE} = KT/q \times \ln(N)$$

where:

K is Boltzmann's constant.

q is charge on the electron (1.6 × 10⁻¹⁹ Coulombs).

T is absolute temperature in Kelvins.

N is the ratio of the two currents.

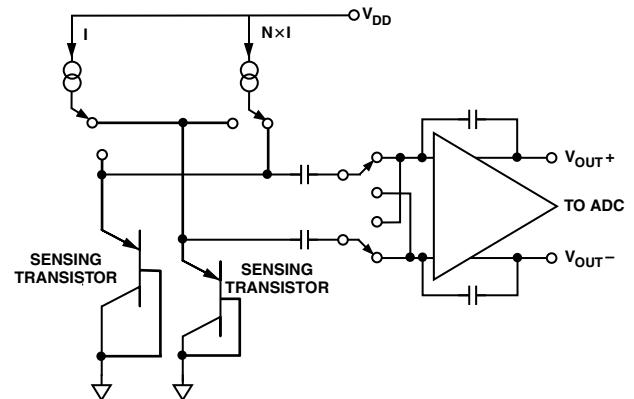

Figure 3. Temperature Measurement Technique

Figure 3 shows the method the AD7414/AD7415 uses to measure the ambient device temperature. To measure ΔV_{BE}, the sensor (substrate transistor) is switched between operating currents of *I* and *N* × *I*. The resulting waveform is passed through a chopper-stabilized amplifier that performs the functions of amplification and rectification of the waveform to produce a dc voltage proportional to DV_{BE}. This voltage is measured by the ADC to give a temperature output in 10-bit two's complement format.

AD7414/AD7415

TEMPERATURE DATA FORMAT

The temperature resolution of the ADC is 0.25°C which corresponds to one LSB of the ADC. The ADC can theoretically measure a temperature span of 255°C; the practical lowest value is limited to -40°C due to device maximum ratings. The A grade can measure a temperature range of -40°C to +85°C. (Temperature data format is shown in Table II.)

Table II. A-Grade Temperature Data Format

Temperature	Digital Output DB9 . . . DB0
-55°C	11 0010 0100
-50°C	11 0011 1000
-25°C	11 1001 1100
-0.25°C	11 1111 1111
0°C	00 0000 0000
+0.25°C	00 0000 0001
+10°C	00 0010 1000
+25°C	00 0110 0100
+50°C	00 1100 1000
+75°C	01 0010 1100
+100°C	01 1001 0000
+125°C	01 1111 0100

A Grade Temperature Conversion Formula:

1. Positive Temperature = ADC Code/4
2. Negative Temperature = (ADC Code* - 512)/4

*DB9 is removed from the ADC Code.

INTERNAL REGISTER STRUCTURE

The AD7414 has five internal registers as shown in Figure 4. Four are data registers and one is an Address Pointer Register.

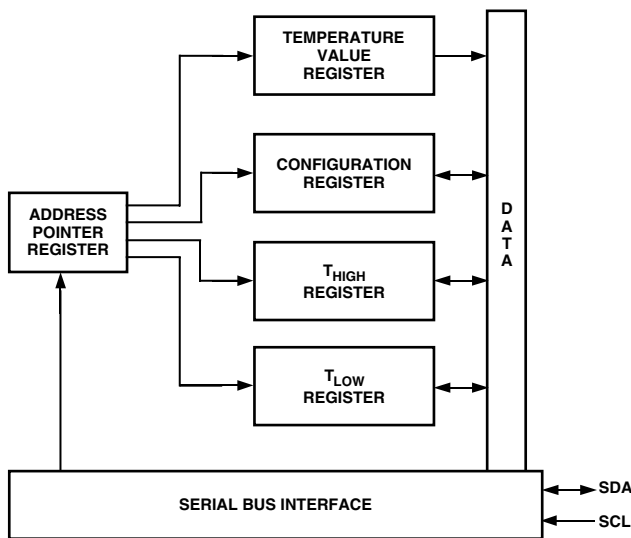

Figure 4. AD7414 Register Structure

The AD7415 has three internal registers as shown in Figure 5. Two are data registers and one is an Address Pointer Register.

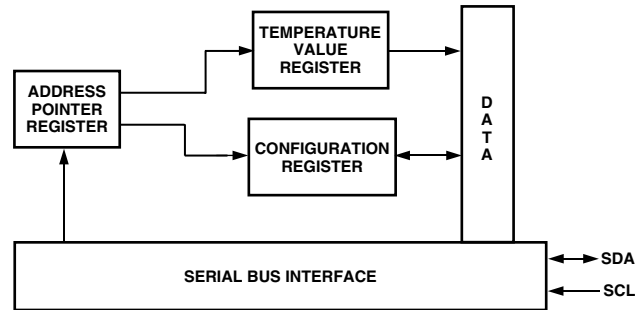

Figure 5. AD7415 Register Structure

Each data register has an address pointed to by the Address Pointer Register when communicating with it. The Temperature Value Register is the only data register that is read only.

ADDRESS POINTER REGISTER

The Address Pointer Register is an 8-bit register that stores an address that points to one of the four data registers of the AD7414 and one of the two data registers of the AD7415. The first byte of every serial write operation to the AD7414/AD7415 is the address of one of the data registers, which is stored in the Address Pointer Register, and selects the data register to which subsequent data bytes are written. Only the two LSBs of this register are used to select a data register.

Table III. Address Pointer Register

P7	P6	P5	P4	P3	P2	P1	P0
0	0	0	0	0	0	Register Select	

Table IV. AD7414 Register Address

P1	P0	Registers
0	0	Temperature Value Register (Read Only)
0	1	Configuration Register (Read/Write)
1	0	T _{HIGH} Register (Read/Write)
1	1	T _{LOW} Register (Read/Write)

Table V. AD7415 Register Address

P1	P0	Registers
0	0	Temperature Value Register (Read Only)
0	1	Configuration Register (Read/Write)

Table VI. AD7414 Configuration Register

D7	D6	D5	D4	D3	D2	D1	D0
PD	FLTR	ALERT $\overline{\text{EN}}$	ALERT POLARITY	ALERT RESET	ONE SHOT	TEST MODE	
0*	1*	0*	0*	0*	0*	0s*	

*Default settings at Power-up.

CONFIGURATION REGISTER (ADDRESS 01H)

The Configuration Register is an 8-bit read/write register that is used to set the operating modes of the AD7414/AD7415. In the AD7414, six of the MSBs are used (D7 to D2) to set the operating modes, see Table VII. D0 and D1 are used for factory settings and must have zeros written to them during normal operation.

Table VII. AD7414 Configuration Register Settings

D7	Full Power-Down if = 1
D6	Bypass SDA and SCL filtering if = 0
D5	Disable ALERT if = 1
D4	ALERT is active low if D4 = 0, ALERT is active high if D4 = 1
D3	Reset the Alert pin if set to 1. The next temperature conversion will have the ability to activate the Alert function. The bit status is not stored, thus this bit will be "0" if read.
D2	Initiate a temperature conversion if set to a 1. The bit status is not stored, thus this bit will be "0" if read.

Table VIII. AD7415 Configuration Register

D7	D6	D5	D4	D3	D2	D1	D0
PD	FLTR	TEST MODE			ONE SHOT	TEST MODE	
0*	1*	0s*			0s*	0s*	

*Default settings at Power-up.

In the AD7415, only three of the bits are used (D7, D6 and D2) to set the operating modes, see Table IX. D0, D1 and D3 to D5 are used for factory settings and must have zeros written to them during normal operation.

Table IX. AD7415 Configuration Register Settings

D7	Full Power-Down if = 1
D6	Bypass SDA and SCL Filtering if = 0
D2	Initiate a temperature conversion if set to a 1. The bit status is not stored, thus this bit will be "0" if read.

If the AD7414/AD7415 is in power-down mode (D7 = 1), a temperature conversion can still be initiated by the one-shot operation. This involves a write operation to the Configuration Register and setting the One-shot Bit to a 1 (D2 = 1) will cause the AD7414/AD7415 to power-up, perform a single conversion and power-down again. This is a very power-efficient mode.

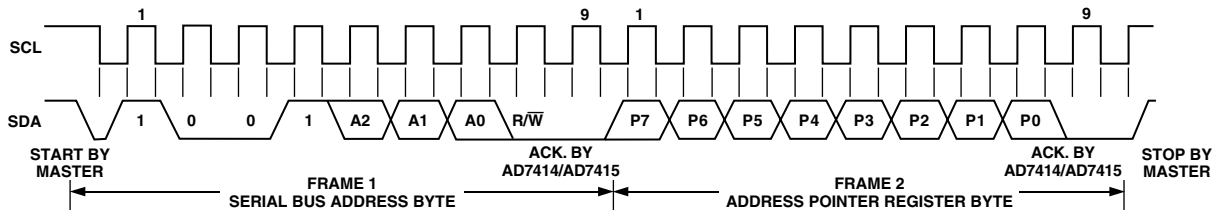

Figure 6. Writing to the Address Pointer Register to Select a Register for a Subsequent Read Operation

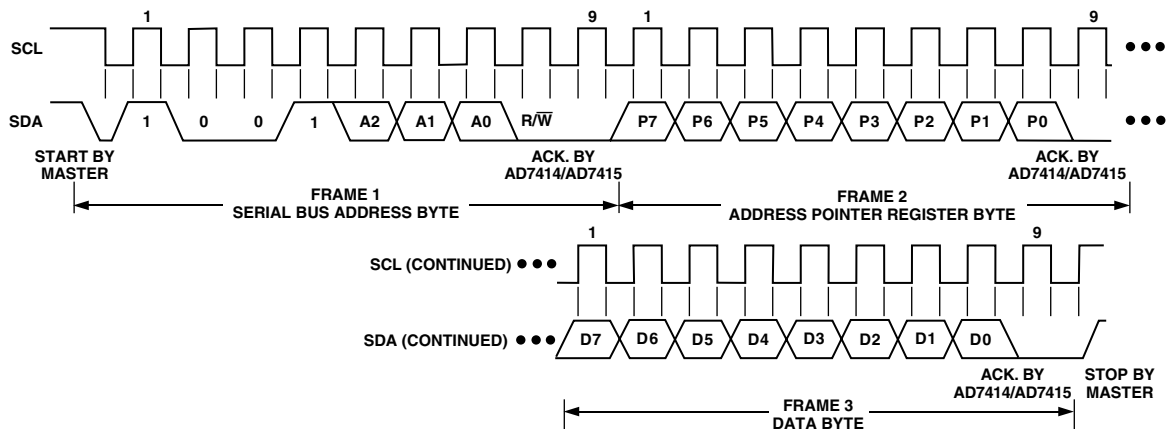

Figure 7. Writing to the Address Pointer Register followed by a Single Byte of Data to the Selected Register

AD7414/AD7415

TEMPERATURE VALUE REGISTER (ADDRESS 00h)

The Temperature Value Register is a 10-bit read-only register that stores the temperature reading from the ADC in two's complement format. Two reads are necessary to read data from this register. Table X shows the contents of the first byte to be read while Table XI and Table XII show the contents of the second byte to be read from AD7414 and AD7415 respectively. In Table XI, D3 to D5 of the second byte are used as flag bits and are obtained from other internal registers. They function as follows:

ALERT_Flag: The state of this bit is same as that of the ALERT pin.

T_{HIGH}_Flag: This flag is set to a 1 when the temperature measured goes above the T_{HIGH} limit. It is reset when the second temperature byte (Table XI) is read. If the temperature is still greater than the T_{HIGH} limit after the read operation, then the flag will be set again.

T_{LOW}_Flag : This flag is set to a 1 when the temperature measured goes below the T_{LOW} limit. It is reset when the second temperature byte (Table XI) is read. If the temperature is still less than the T_{LOW} limit after the read operation, then the flag will be set again.

The full theoretical span of the ADC is 255°C, but in practice the temperature measurement range is limited to the operating range of the device, -40°C to +85°C for A grade.

Table X. Temperature Value Register (First Read)

D15	D14	D13	D12	D11	D10	D9	D8
MSB	B8	B7	B6	B5	B4	B3	B2

Table XI. AD7414 Temperature Value Register (Second Read)

D7	D6	D5	D4	D3	D2	D1	D0
B1	LSB	ALERT Flag	T _{HIGH} Flag	T _{LOW} Flag	0	0	0

Table XII. AD7415 Temperature Value Register (Second Read)

D7	D6	D5	D4	D3	D2	D1	D0
B1	LSB	N/A	N/A	N/A	N/A	N/A	N/A

AD7414 T_{HIGH} REGISTER (Address 02h)

The T_{HIGH} Register is an 8-bit read/write register that stores the upper limit that will activate the ALERT output. Therefore, if the value in the Temperature Value Register is greater than the value in the T_{HIGH} Register, then the ALERT pin is activated (that is, if ALERT is enabled in the Configuration Register). As it is an 8-bit register the temperature resolution is 1°C.

Table XIII. T_{HIGH} Register

D7	D6	D5	D4	D3	D2	D1	D0
MSB	B6	B5	B4	B3	B2	B1	B0

AD7414 T_{LOW} REGISTER (Address 03h)

The T_{LOW} Register is an 8-bit read/write register that stores the lower limit that will deactivate the ALERT output. Therefore, if the value in the Temperature Value Register is less than the value in the T_{LOW} Register, the ALERT pin is deactivated (that is, if ALERT is enabled in the Configuration Register). As it is an 8-bit register, the temperature resolution is 1°C.

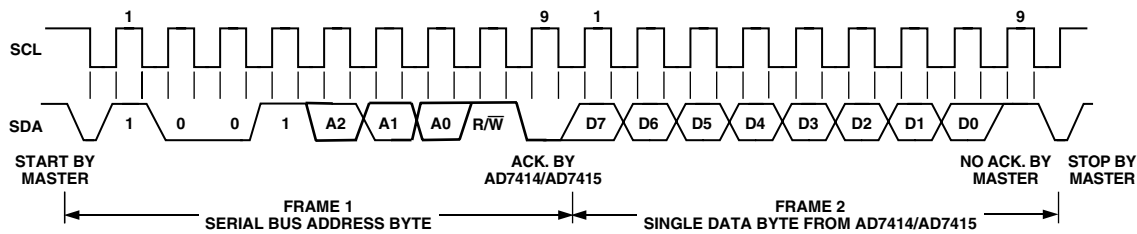

Figure 8. Reading a Single Byte of Data from a Selected Register

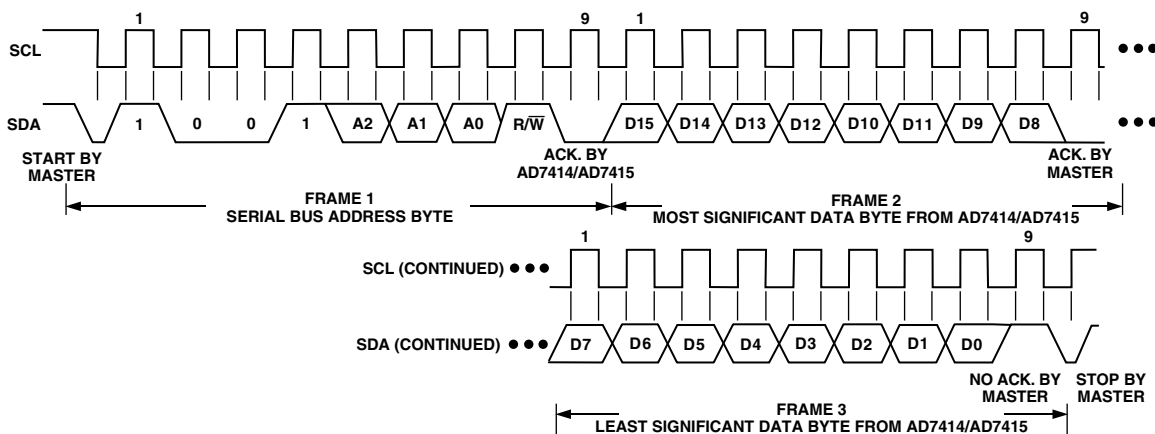

Table XIV. T_{LOW} Register

D7	D6	D5	D4	D3	D2	D1	D0
MSB	B6	B5	B4	B3	B2	B1	B0

AD7414/AD7415 SERIAL INTERFACE

Control of the AD7414/AD7415 is carried out via the I²C-compatible serial bus. The AD7414/AD7415 is connected to this bus as a slave device, under the control of a master device, e.g., the processor.

SERIAL BUS ADDRESS

Like all I²C-compatible devices, the AD7414/AD7415 has a 7-bit serial address. The four MSBs of this address for the AD7414/AD7415 are set to 1001. The AD7414/AD7415 comes in four versions, the AD7414/AD7415-0, AD7414/AD7415-1, AD7414-2 and the AD7414-3. The first two versions have three different I²C addresses available which are selected by either tying the AS pin to GND, to VDD or letting the pin float (see Table I). By giving different addresses for the four versions, up to eight AD7414s or six AD7415s can be connected to a single, serial bus, or the addresses can be set to avoid conflicts with other devices on the bus.

The serial bus protocol operates as follows:

1. The master initiates data transfer by establishing a START condition, defined as a high to low transition on the serial data line SDA while the serial clock line SCL remains high. This indicates that an address/data stream will follow. All slave peripherals connected to the serial bus respond to the START condition, and shift in the next eight bits, consisting of a 7-bit address (MSB first) plus a R \overline{W} bit, which determines the direction of the data transfer, i.e. whether data will be written to or read from the slave device.

The peripheral whose address corresponds to the transmitted address responds by pulling the data line low during the low period before the ninth clock pulse, known as the Acknowledge bit. All other devices on the bus now remain idle while the selected device waits for data to be read from or written to it. If the R \overline{W} bit is a 0 then the master will write to the slave device. If the R \overline{W} bit is a 1 the master will read from the slave device.

2. Data is sent over the serial bus in sequences of nine clock pulses, eight bits of data followed by an Acknowledge Bit from the receiver of data. Transitions on the data line must occur during the low period of the clock signal and remain stable during the high period, as a low to high transition when the clock is high may be interpreted as a STOP signal.
3. When all data bytes have been read or written, stop conditions are established. In WRITE mode, the master will pull the data line high during the 10th clock pulse to assert a STOP condition. In READ mode, the master device will pull the data line high during the low period before the 9th clock pulse. This is known as No Acknowledge. The master will then take the data line low during the low period before the tenth clock pulse, then high during the tenth clock pulse to assert a STOP condition.

Any number of bytes of data may be transferred over the serial bus in one operation, but it is not possible to mix read and write in one operation, because the type of operation is determined at the beginning and cannot subsequently be changed without starting a new operation.

WRITING TO THE AD7414/AD7415

Depending on the register being written to, there are two different writes for the AD7414/AD7415.

Writing to the Address Pointer Register for a Subsequent Read

In order to read data from a particular register, the Address Pointer Register must contain the address of that register. If it does not, the correct address must be written to the Address Pointer Register by performing a single-byte write operation, as shown in Figure 6. The write operation consists of the serial bus address followed by the address pointer byte. No data is written to any of the data registers. A read operation is then performed to read the register.

Writing a Single Byte of Data to the Configuration Register, T_{HIGH} Register or T_{LOW} Register

All three registers are 8-bit registers so only one byte of data can be written to each register. Writing a single byte of data to one of these registers consists of the serial bus address, the Data Register address written to the Address Pointer Register, followed by the data byte written to the selected data register. This is illustrated in Figure 7.

READING DATA FROM THE AD7414/AD7415

Reading data from the AD7414/AD7415 is a one or two byte operation. Reading back the contents of the Configuration Register, T_{HIGH} Register or T_{LOW} Register is a single byte read operation as shown in Figure 8. The register address previously having been set up by a single byte write operation to the Address Pointer Register. Once the register address has been set up, any number of reads can be subsequently done from that register without having to write to the Address Pointer Register again. If you want to read from another register then you will have to write to the Address Pointer Register again to set up the relevant register address.

Reading data from the Temperature Value Register is a two byte operation as shown in Figure 9. The same rules apply for a two byte read as a single byte read.

SMBus ALERT

The AD7414 ALERT output is an SMBus interrupt line for devices that want to trade their ability to master for an extra pin. The AD7414 is a slave only device and uses the SMBus ALERT to signal the host device that it wants to talk. The SMBus ALERT on the AD7414 is used as an over temperature indicator.

The ALERT pin has an open-drain configuration which allows the ALERT outputs of several AD7414s to be wired-AND together when the ALERT pin is active low. Use D4 of the Configuration Register to set the active polarity of the ALERT output. The power-up default is active low. The ALERT function can be disabled or enabled by setting D5 of the Configuration Register to 1 or 0 respectively.

AD7414/AD7415

The host device can process the ALERT interrupt and simultaneously access all SMBus ALERT devices through the alert response address. Only the device that pulled the ALERT low will acknowledge the ARA (Alert Response Address). If more than one device pulls the ALERT pin low, the highest priority (lowest address) device will win communication rights via standard I²C arbitration during the slave address transfer.

The ALERT output becomes active when the value in the Temperature Value Register exceeds the value in the T_{HIGH} Register. It is reset when a write operation to the Configuration register sets D3 to a 1 or when the temperature falls below the value stored in the T_{LOW} Register.

The ALERT output requires an external pull-up resistor. This can be connected to a voltage different from V_{DD} provided the maximum voltage rating of the ALERT output pin is not exceeded. The value of the pull-up resistor depends on the application, but should be as large as possible to avoid excessive sink currents at the ALERT output, which can heat the chip and affect the temperature reading.

POWER-ON DEFAULTS

The AD7414/AD7415 always powers up with the following defaults:

Address Pointer Register pointing to the Temperature Value Register.

T_{HIGH} Register loaded with 7F Hex.

T_{LOW} Register loaded with 80 Hex.

Configuration Register loaded with 40 Hex.

Note: The AD7415 does not have any T_{HIGH} or T_{LOW} registers.

OPERATING MODES

Mode 1

This is the power-on default mode of the AD7414/AD7415. In this mode the AD7414/AD7415 does a temperature conversion every 800 ms and then partially powers down until the next conversion occurs.

If a one-shot operation (setting D2 of the Configuration register to a 1) is performed between automatic conversions, a conversion is initiated right after the write operation. After this conversion, the part returns to performing a conversion every 800 ms.

Depending on where a serial port access occurs during a conversion, that conversion might or might not be aborted. If the conversion is completed before the part recognizes a serial port access then the Temperature Register will be updated with the new conversion. If the conversion is completed after the part recognizes a serial port access then the internal logic will prevent the Temperature Register from being updated as corrupt data could be read.

A temperature conversion can start anytime during a serial port access (other than a one-shot operation), but the result of that conversion will only be loaded into the Temperature Register if serial port access is not active at the end of the conversion.

Mode 2

The only other mode in which the AD7414/AD7415 operates is the full power-down mode. This mode is usually used when temperature measurements are required at a very slow rate. The power consumption of the part can be greatly reduced in this mode by writing to the part to go to a full power-down. Full power-down is initiated right after D7 of the Configuration Register set to a 1.

When a temperature measurement is required, a write operation can be performed to power-up the part and put it into one-shot mode (setting D2 of the Configuration register to a 1). The power-up takes approximately 4 ms. The part then performs a conversion and is returned to full power-down. The temperature value can be read in the full power-down mode as the serial interface is still powered up.

POWER VS. THROUGHPUT

The two modes of operation for the AD7414/AD7415 will produce different power versus throughput performances. Mode 2 is the sleep mode of the part and it achieves the optimum power performance.

Mode 1

In this mode continuous conversions are performed at a rate of approximately one every 800 ms. Figure 10 shows the times and the currents involved with this mode of operation for a 5 V supply. At 5 V the current consumption for the part when converting is 1.1 mA typically and the quiescent current is 188 μA typically. The conversion time of 25 μs plus power-up time of typically 4 μs contributes 199.3 nW to the overall power dissipation in the following way:

$$(29 \mu\text{s}/800 \text{ ms}) \times (5 \times 1.1 \text{ mA}) = 199.3 \text{ nW}$$

The contribution to the total power dissipated by the remaining time is 939.96 μW.

$$(799.971 \text{ ms}/800 \text{ ms}) \times (5 \times 188 \mu\text{A}) = 939.96 \mu\text{W}$$

Thus the total power dissipated during each cycle is:

$$199.3 \text{ nW} + 939.96 \mu\text{W} = 940.16 \mu\text{W}$$

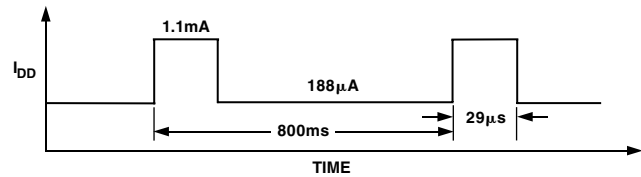

Figure 10. Mode 1 Power Dissipation

Mode 2

In this mode the part is totally powered down. All circuitry except the serial interface is switched off. The most power efficient way of operating in this mode is to use the one-shot method. Write to the configuration register and set the one-shot bit to a 1. The part will power-up in approximately 4 ms and then perform a conversion. Once the conversion is finished the device will power down again until the PD bit in the configuration register is set to a 0 or the one-shot bit is set to a 1. Figure 11 shows the same timing as Figure 10 in mode 1, a one-shot is initiated every 800 ms. If we take the voltage supply to be 5 V we can work out the power dissipation in the following way. The current consumption for the part when converting is 1.1 mA typically and the quiescent current is 800 nA typically. The conversion time of 25 μs plus power-up time of typically 4 ms contributes 199.3 nW to the overall power dissipation in the following way:

$$(29 \mu\text{s}/800 \text{ ms}) \times (5 \text{ V} \times 1.1 \text{ mA}) = 199.3 \text{ nW}$$

The contribution to the total power dissipated by the remaining time is 3.9 μW.

$$(799.971 \text{ ms}/800 \text{ ms}) \times (5 \text{ V} \times 800 \text{ nA}) = 3.9 \mu\text{W}$$

Thus the total power dissipated during each cycle is:

$$199.3 \text{ nW} + 3.9 \mu\text{W} = 4.1 \mu\text{W}$$

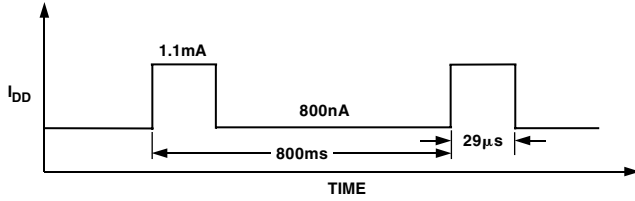

Figure 11. Mode 2 Power Dissipation

MOUNTING THE AD7414/AD7415

The AD7414/AD7415 can be used for surface or air-temperature sensing applications. If the device is cemented to a surface with thermally conductive adhesive, the die temperature will be within about 0.1°C of the surface temperature, thanks to the device’s low power consumption. Care should be taken to insulate the back and leads of the device from the air, if the ambient air temperature is different from the surface temperature being measured.

The ground pin provides the best thermal path to the die, so the temperature of the die will be close to that of the printed circuit ground track. Care should be taken to ensure that this is in good thermal contact with the surface being measured.

As with any IC, the AD7414/AD7415 and its associated wiring and circuits must be kept free from moisture to prevent leakage and corrosion, particularly in cold conditions where condensation is more likely to occur. Water-resistant varnishes and conformal coatings can be used for protection. The small size of the AD7414/AD7415 packages allows it to be mounted inside sealed metal probes, which provide a safe environment for the device.

SUPPLY DECOUPLING

The AD7414/AD7415 should be at least decoupled with a 0.1 µF ceramic capacitor between V_{DD} and GND. This is particularly important if the AD7414/AD7415 is mounted remote from the power supply.

TEMPERATURE ACCURACY VS. SUPPLY

The Temperature Accuracy specifications are guaranteed for voltage supplies of 3 V and 5.5 V only. Figure 12 gives the typical performance characteristics of a large sample of parts over the full voltage range of 2.7 V to 5.5 V. Figure 13 gives the typical performance characteristics of one part over the full voltage range of 2.7 V to 5.5 V.

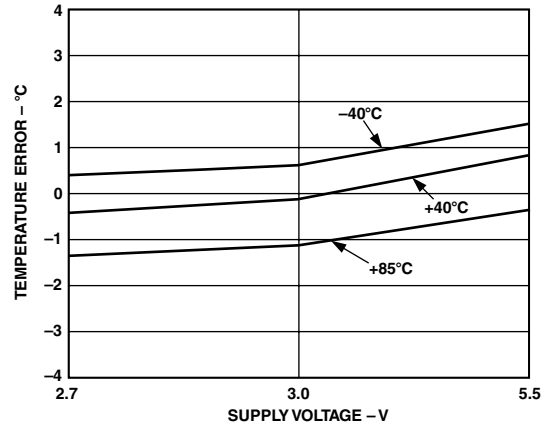

Figure 12. Typical Temperature Error vs. Supply for Large Sample of Parts

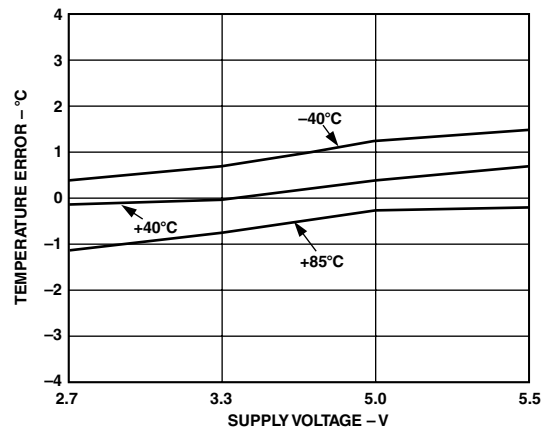

Figure 13. Typical Temperature Error vs. Supply for One Part

TYPICAL TEMPERATURE ERROR GRAPH

Figure 14 shows typical temperature error plots for one device with V_{DD} at 3.3 V and at 5.5 V.

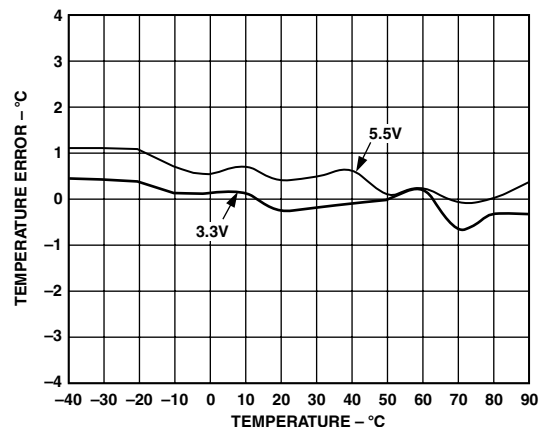
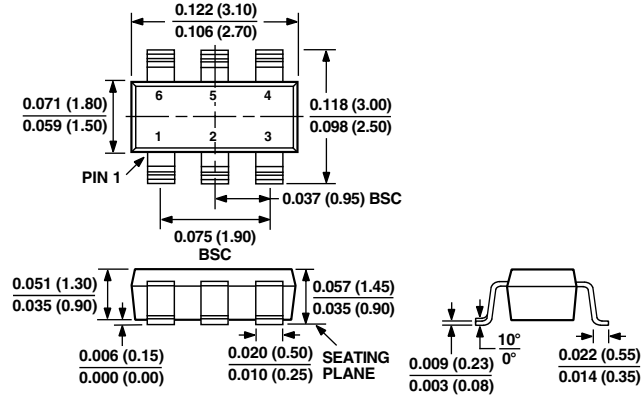

Figure 14. Typical Temperature Error @ 3.3 V and 5.5 V

OUTLINE DIMENSIONS

Dimensions shown in inches and (mm).

6-Lead Plastic Surface-Mount SOT-23 (RT-6)



8-Lead Mini_SO (RM-8)

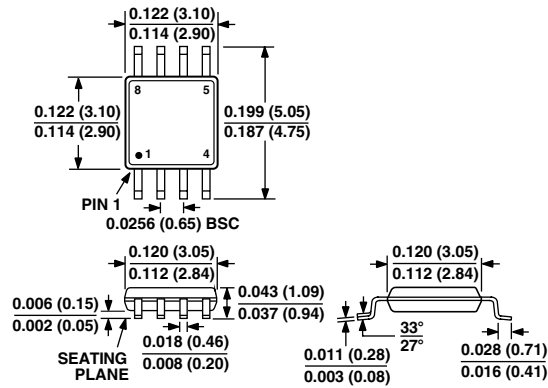

5-Lead Plastic Surface-Mount SOT-23 (RT-5)

