



Li-MnO₂ Battery

----CR1/3N Brief Datasheet----

1. BASIC SPECIFICATION

➤ Model:	CR1/3N
➤ Nominal Voltage:	3.0Volts
➤ Nominal Capacity:	(@ 1.0mA Discharge Current to 2.0V cut-off, +23°C) 160mAh
➤ Standard Discharge Current:	1.0mA
➤ Maximum recommended current under continuous discharge:	5.0mA
➤ Maximum recommended current under pulse discharge:	80mA
➤ Operational temperature range:	-30°C~+60°C
➤ Nominal Weight:	3.3g

2. MAIN FEATURES

- Light Weight, High Voltage and High Energy Density
- Excellent Stable Discharge Characteristics and outstanding Temperature Characteristics
- Outstanding Temperature Characteristics
- Excellent Leakage Resistance and Excellent Long-term Reliability

3. ELECTRICAL CHARACTERISTICS

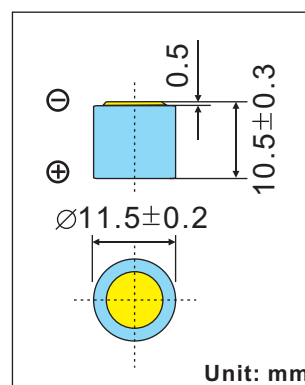
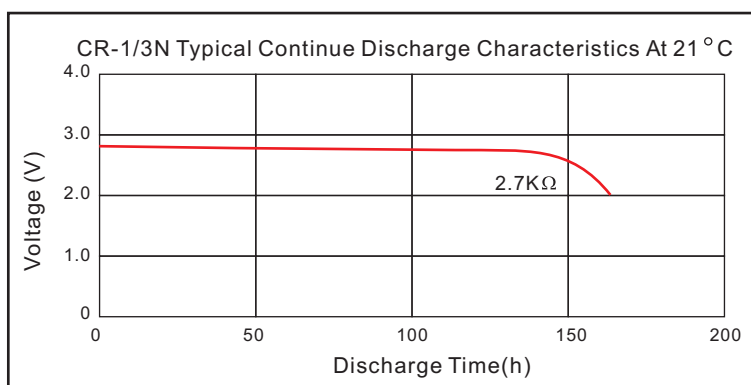

4. WARNING!

- DO NOT recharge, short-circuit, disassemble, deform, heat or place the battery near a direct flame. Any of the above actions could cause it to ignite explode or become damaged.
- Keep this battery out of the reach of children.
- When storing the battery or thro wing it away, be sure to cover it with tape.