



DALC208SC6

Application Specific Discretés
A.S.D.™

LOW CAPACITANCE
DIODE ARRAY

MAIN APPLICATIONS

Where ESD and/or over and undershoot protection for datalines is required :

- Sensitive logic input protection
- Microprocessor based equipment
- Audio / Video inputs
- Portable electronics
- Networks
- ISDN equipment
- USB interface

DESCRIPTION

The DALC208SC6 diode array is designed to protect components which are connected to data and transmission lines from overvoltages caused by electrostatic discharge (ESD) or other transients. It is a rail-to-rail protection device also suited for overshoot and undershoot suppression on sensitive logic inputs.

The low capacitance of the DALC208SC6 prevents from significant signal distortion.

FEATURES

- PROTECTION OF 4 LINES
- PEAK REVERSE VOLTAGE:
 $V_{RRM} = 9\text{ V}$ per diode
- VERY LOW CAPACITANCE PER DIODE:
 $C < 5\text{ pF}$
- VERY LOW LEAKAGE CURRENT: $I_R < 1\text{ }\mu\text{A}$

BENEFITS

- Cost-effectiveness compared to discrete solution
- High efficiency in ESD suppression
- No significant signal distortion thanks to very low capacitance
- High reliability offered by monolithic integration
- Lower PCB area consumption versus discrete solution

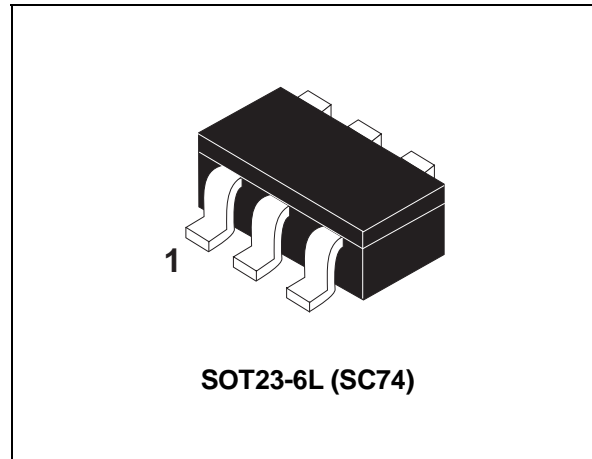

FUNCTIONAL DIAGRAM

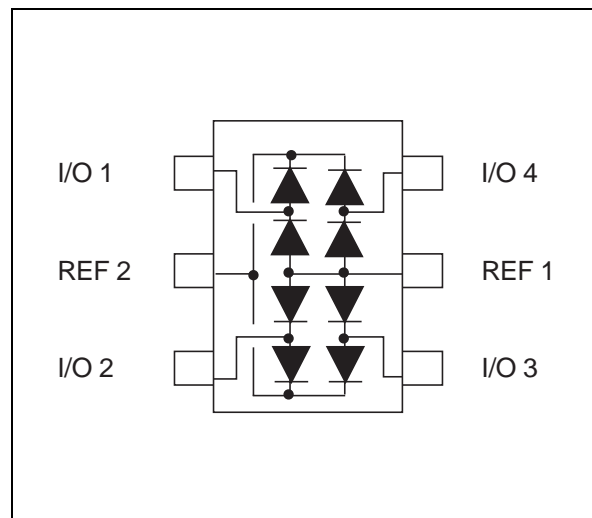

COMPLIES WITH THE FOLLOWING STANDARDS :

IEC 1000-4-2	level 4
MIL STD 883C - Method 3015-6 (human body test)	class 3

DALC208SC6

ABSOLUTE MAXIMUM RATINGS ($T_{amb} = 25^{\circ}\text{C}$).

Symbol	Parameter	Value	Unit
V_{PP}	IEC1000-4-2, air discharge IEC1000-4-2, contact discharge	15 8	kV
V_{RRM}	Peak reverse voltage per diode	9	V
ΔV_{REF}	Reference voltage gap between V_{REF2} and V_{REF1}	9	V
$V_{In\ max.}$	Maximum operating signal input voltage	V_{REF2}	V
$V_{In\ min.}$	Minimum operating signal input voltage	V_{REF1}	V
I_F	Continuous forward current (single diode loaded)	200	mA
I_{FRM}	Repetitive peak forward current ($t_p = 5\ \mu\text{s}$, $F = 50\ \text{kHz}$)	700	mA
I_{FSM}	Surge non repetitive forward current - rectangular waveform (see curve on figure 1) $t_p = 2.5\ \mu\text{s}$ $t_p = 1\ \text{ms}$ $t_p = 100\ \text{ms}$	6 2 1	A
T_{stg} T_j	Storage temperature range Maximum junction temperature	-55 to + 150 150	$^{\circ}\text{C}$ $^{\circ}\text{C}$

THERMAL RESISTANCE

Symbol	Parameter	Value	Unit
$R_{th(j-a)}$	Junction to ambient (note 1)	500	$^{\circ}\text{C/W}$

Note 1: device mounted on FR4 PCB with recommended footprint dimensions.

ELECTRICAL CHARACTERISTICS ($T_{amb} = 25^{\circ}\text{C}$).

Symbol	Parameter	Conditions	Typ.	Max.	Unit
V_F	Forward voltage	$I_F = 50\ \text{mA}$		1.2	V
I_R	Reverse leakage current per diode	$V_R = 5\ \text{V}$		1	μA
C	Input capacitance between Line and GND	see note 3	7		pF

Note 2: The dynamical behavior is described in the Technical Information section, on page 4.

Note 3: Input capacitance measurement

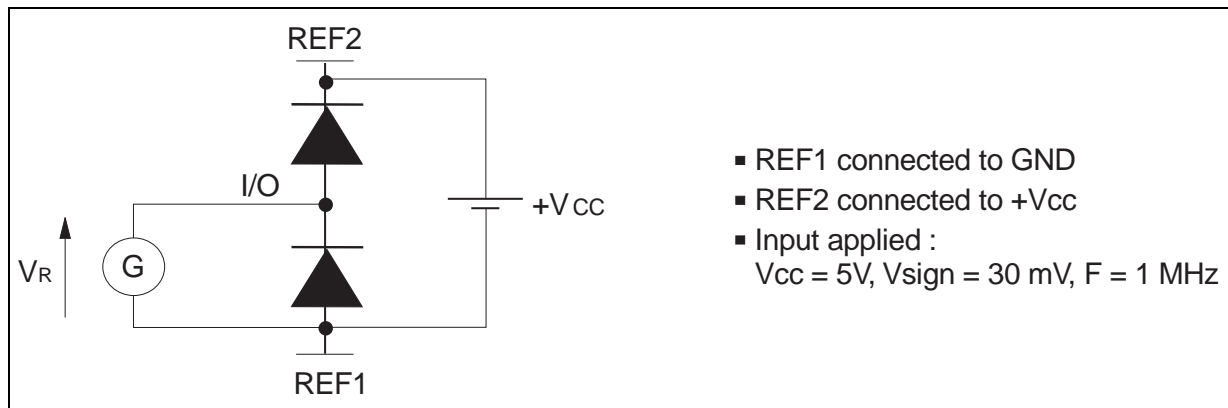

Fig. 1: Maximum non-repetitive peak forward current versus rectangular pulse duration (T_j initial = 25°C).

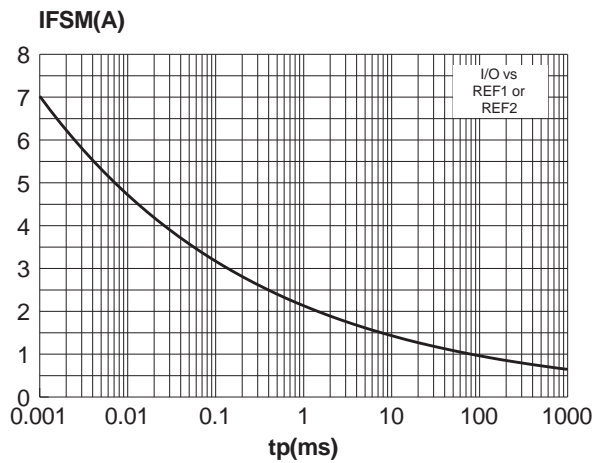

Fig. 2: Reverse clamping voltage versus peak pulse current (T_j initial = 25°C), typical values. Rectangular waveform $t_p = 2.5 \mu s$.

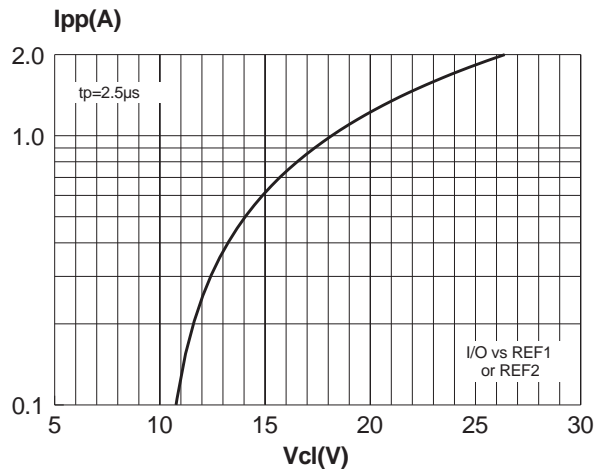

Fig. 3: Variation of leakage current versus junction temperature (typical values).

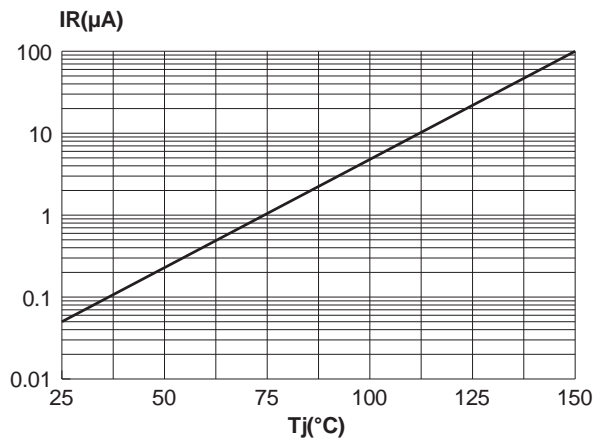

Fig. 4: Input capacitance versus reverse applied voltage (typical values).

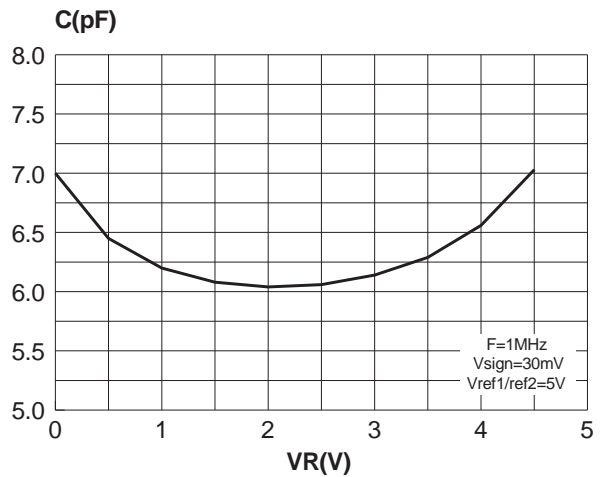
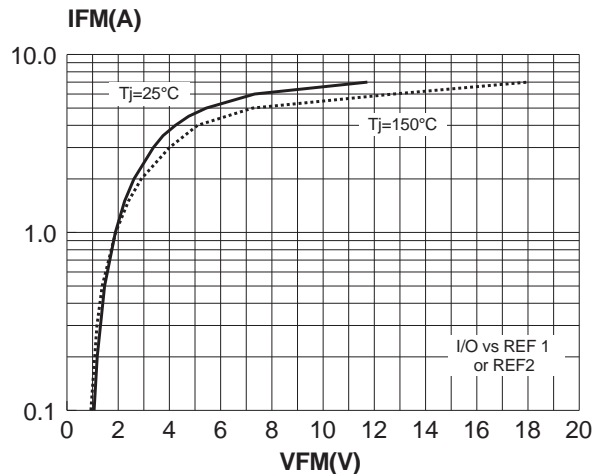

Fig. 5: Peak forward voltage drop versus peak forward current (typical values). Rectangular waveform $t_p = 2.5 \mu s$.



TECHNICAL INFORMATION

SURGE PROTECTION

The DALC208SC6 is particularly optimized to perform surge protection based on the rail to rail topology.

The clamping voltage V_{CL} can be calculated as follow :

$$V_{CL+} = V_{REF2} + V_F \quad \text{for positive surges}$$

$$V_{CL-} = V_{REF1} - V_F \quad \text{for negative surges}$$

with : $V_F = V_t + r_d \cdot I_p$

(V_F forward drop voltage) / (V_t forward drop threshold voltage)

According to the curve Fig.5 on page 3, we assume that the value of the dynamic resistance of the clamping diode is typically $r_d = 0.7\Omega$ and $V_t = 1.2V$.

For an IEC 1000-4-2 surge Level 4 (Contact Discharge: $V_g=8kV$, $R_g=330\Omega$), $V_{REF2} = +5V$, $V_{REF1} = 0V$, and if in first approximation, we assume that : $I_p=V_g/R_g \approx 24A$.

So, we find:

$$V_{CL+} \approx +23V$$

$$V_{CL-} \approx -18V$$

Note: the calculations do not take into account phenomena due to parasitic inductances

APPLICATION EXAMPLE

If we consider that the connections from the pin REF_2 to V_{CC} and from REF_1 to GND are done by two tracks of 10mm long and 0.5mm large; we assume that the parasitic inductances of these tracks are about 6nH.

So when an IEC 1000-4-2 surge occurs, due to the rise time of this spike ($t_r=1ns$), the voltage V_{CL} has an extra value equal to $L_w \cdot di/dt$.

The di/dt is calculated as: $di/dt = I_p/t_r \approx 24 A/ns$

The overvoltage due to the parasitic inductances is: $L_w \cdot di/dt = 6 \times 24 \approx 144V$

By taking into account the effect of these parasitic inductances due to unsuitable layout, the clamping voltage will be :

$$V_{CL+} = +23 + 144 \approx 167V$$

$$V_{CL-} = -18 - 144 \approx -162V$$

We can reduce as much as possible these phenomena with simple layout optimization.

It's the reason why some recommendations have to be followed (see paragraph "How to ensure a good ESD protection").

Fig. A1: ESD behavior; parasitic phenomena due to unsuitable layout.

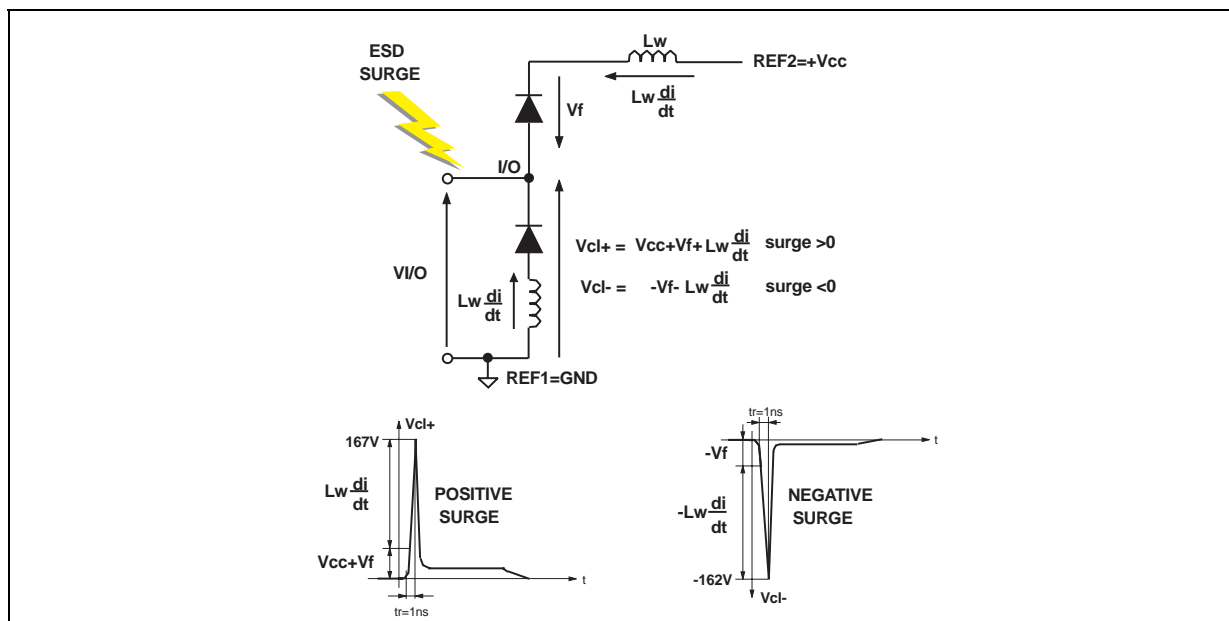

HOW TO ENSURE A GOOD ESD PROTECTION

While the DALC208SC6 provides a high immunity to ESD surge, an efficient protection depends on the layout of the board. In the same way, with the rail to rail topology, the track from the VREF2 pin to the power supply +VCC and from the VREF1 pin to GND must be as short as possible to avoid overvoltages due to parasitic phenomena (see Fig. A1).

It's often harder to connect the power supply near to the DALC208SC6 unlike the ground thanks to the ground plane that allows a short connection.

To ensure the same efficiency for positive surges when the connections can't be short enough, we recommend to put close to the DALC208SC6, between VREF2 and ground, a capacitance of 100nF to prevent from these kinds of overvoltage disturbances (see Fig. A2).

The add of this capacitance will allow a better protection by providing during surge a constant voltage.

Fig. A3, A4a and A4b show the improvement of the ESD protection according to the recommendations described above.

Fig. A2: ESD behavior: optimized layout and add of a capacitance of 100nF.

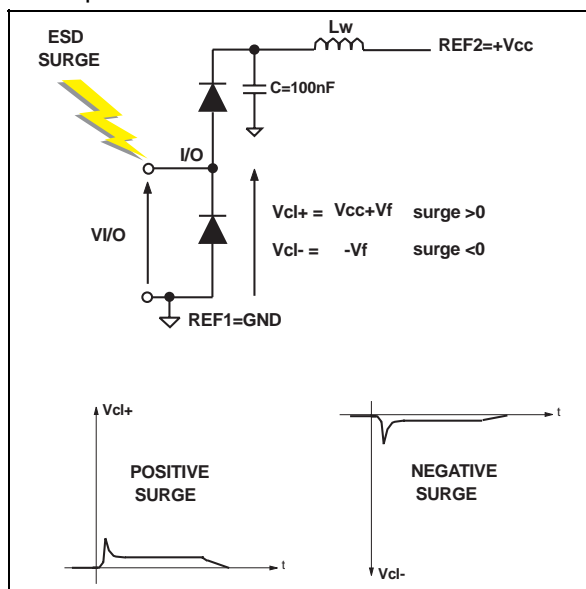

Important:

A main precaution to take is to put the protection device closer to the disturbance source (generally the connector).

Note: The measurements have been done with the DALC208SC6 in open circuit.

Fig. A3: ESD behavior: measurements conditions (with coupling capacitance).

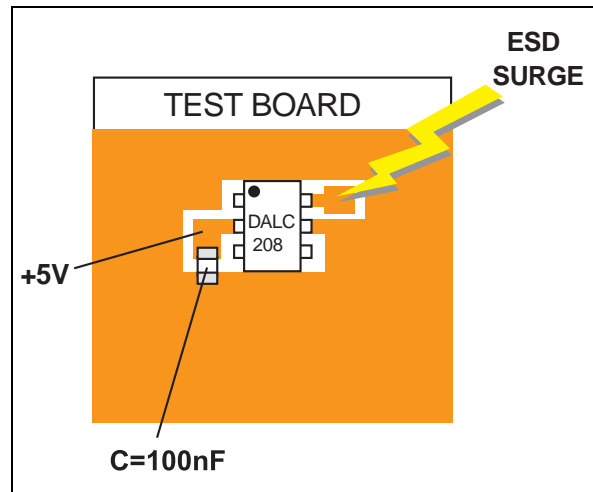

Fig. A4a: Remaining voltage after the DALC208SC6 during positive ESD surge.

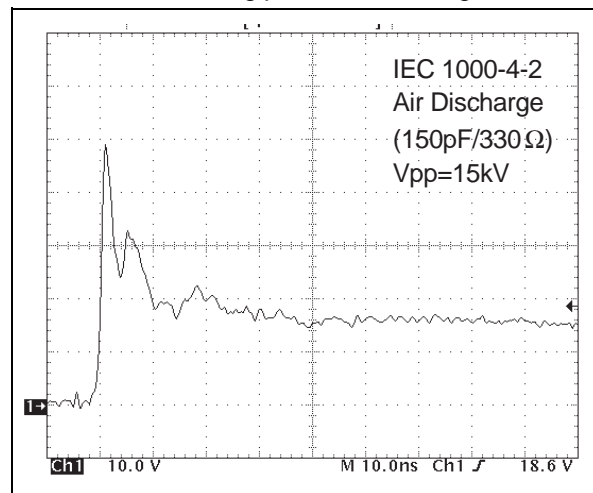
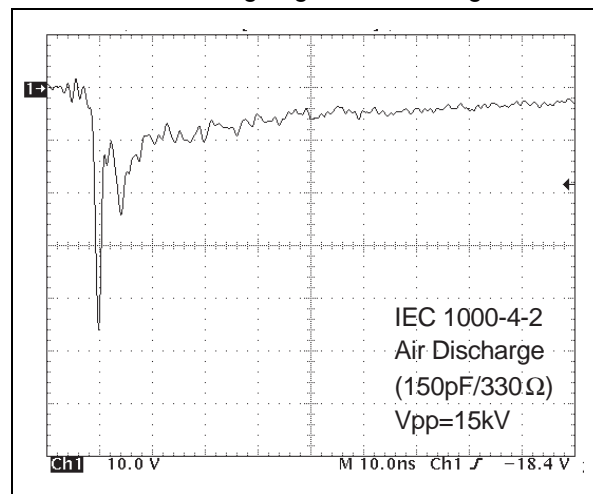

Fig. A4b: Remaining voltage after the DALC208SC6 during negative ESD surge.



CROSSTALK BEHAVIOR

1- Crosstalk phenomena

Fig. A4: Crosstalk phenomena.

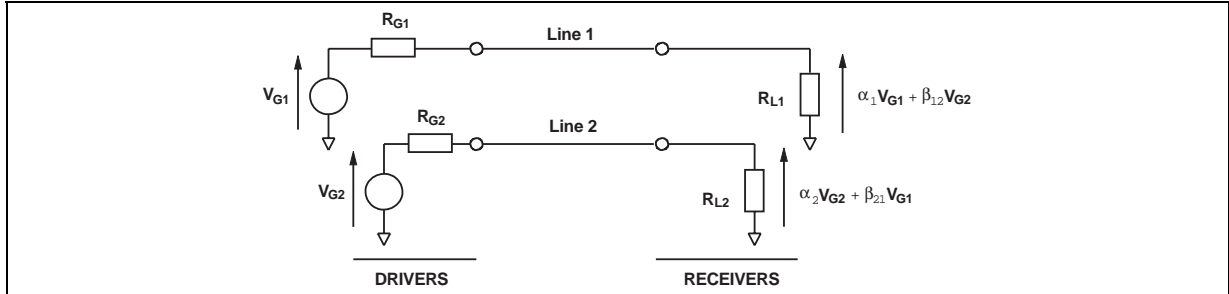

The crosstalk phenomena are due to the coupling between 2 lines. The coupling factor (β_{12} or β_{21}) increases when the gap across lines decreases, particularly in silicon dice. In the example above the expected signal on load R_{L2} is $\alpha_2 V_{G2}$, in fact the real voltage at this point has got an extra value $\beta_{21} V_{G1}$. This part of the V_{G1} signal represents the effect of the crosstalk phenomenon of the line 1 on the line 2. This phenomenon has to be taken into account when the drivers impose fast digital data or high frequency analog signals in the disturbing line. The perturbed line will be more affected if it works with low voltage signal or high load impedance (few $k\Omega$). The following chapters give the value of both digital and analog crosstalk.

2- Digital Crosstalk

Fig. A5: Digital crosstalk measurements.

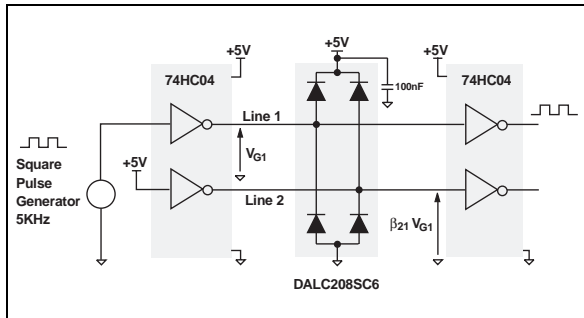
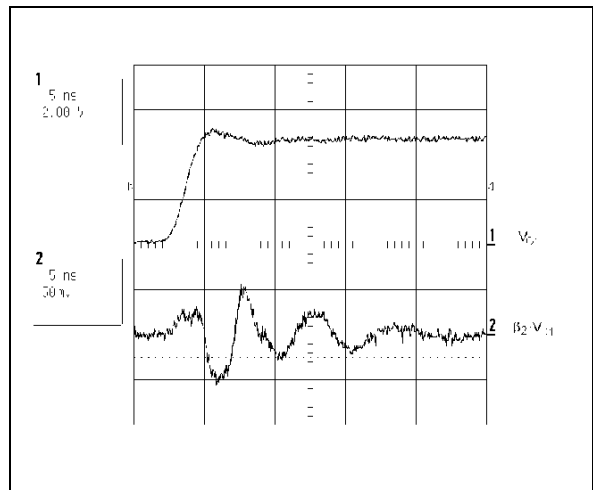

Figure A5 shows the measurement circuit used to quantify the crosstalk effect in a classical digital application.

Figure A6 shows that in such a condition: signal from 0V to 5V and a rise time of 5 ns, the impact on the disturbed line is less than 100mV peak to peak. No data disturbance was noted on the concerned line. The same results were obtained with falling edges.

Fig. A6: Digital crosstalk results.



Note: The measurements have been done in the worst case i.e. on two adjacent cells (I/O1 & I/O4).

3- Analog Crosstalk

Fig. A7: Analog crosstalk measurements.

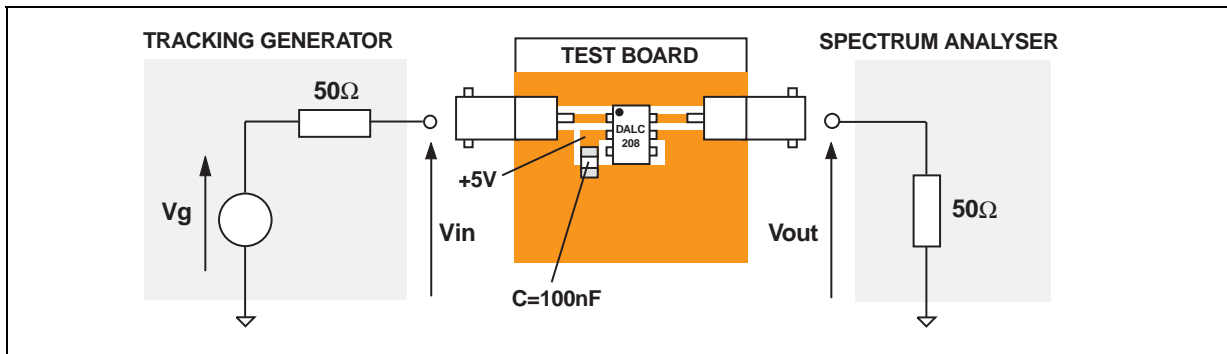
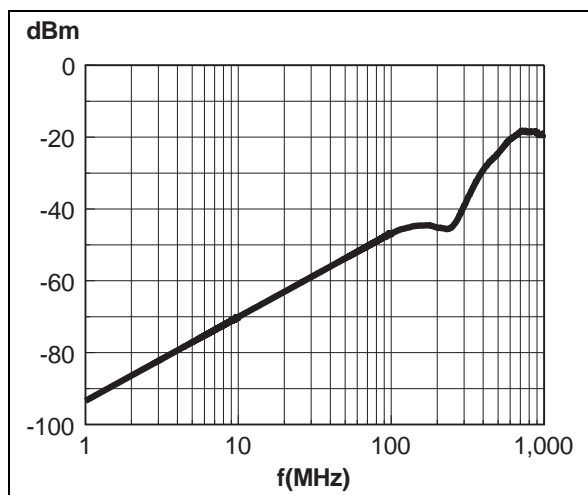

Figure A7 gives the measurement circuit for the analog application. In usual frequency range of analog signals (up to 100MHz) the effect on disturbed line is less than -45 dBm (please see Fig. A8).

Fig. A8: Analog crosstalk results.



As the DALC208SC6 is designed to protect high speed data lines, it must ensure a good transmission of operating signals. The attenuation curve give such an information.

Fig. A10 shows that the DALC208SC6 is well suitable for data line transmission up to 100 Mbit/s while it works as a filter for undesirable signals as GSM (900MHz).

Fig. A9: Measurement conditions.

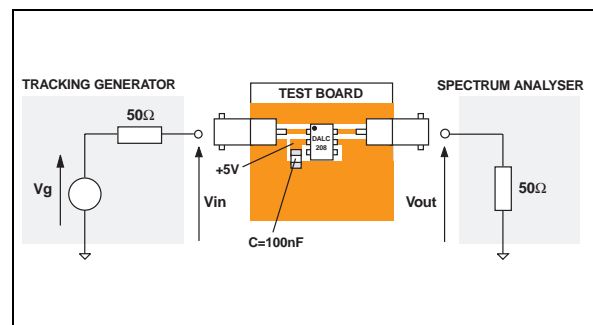
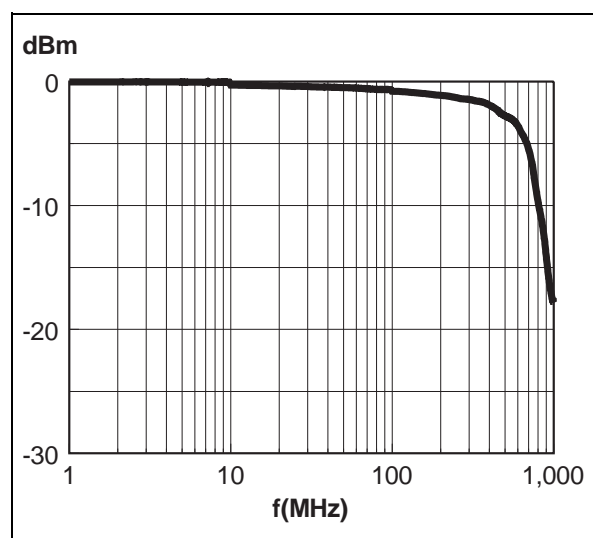

Fig. A10: DALC206SC6 attenuation.



DALC208SC6

APPLICATION EXAMPLES

■ Video line protection

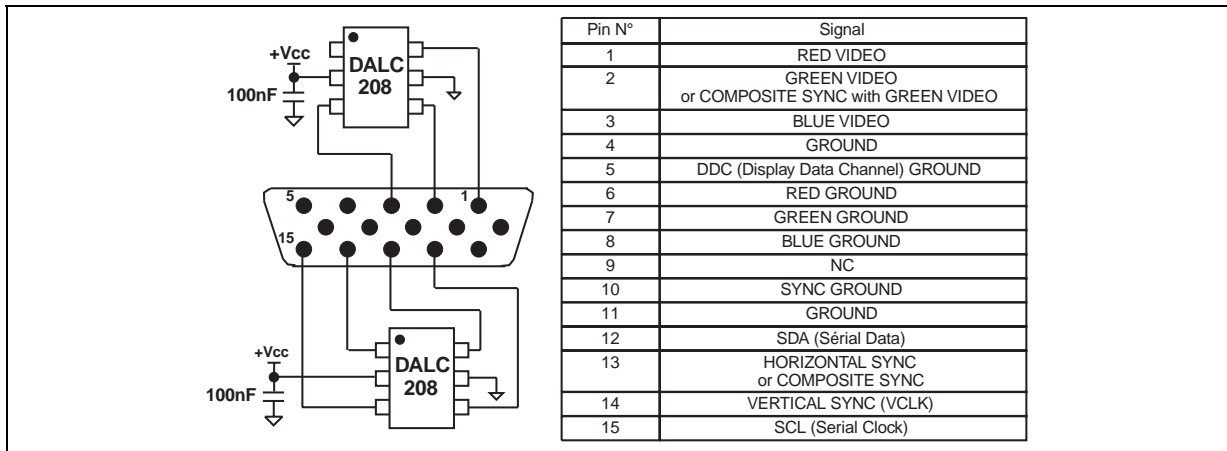

■ T1/E1 protection

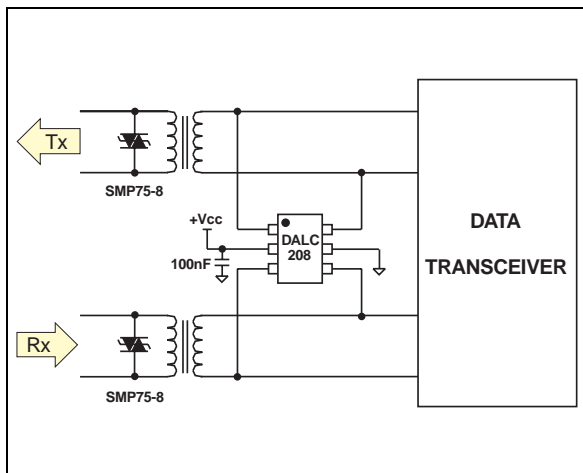

■ USB port protection

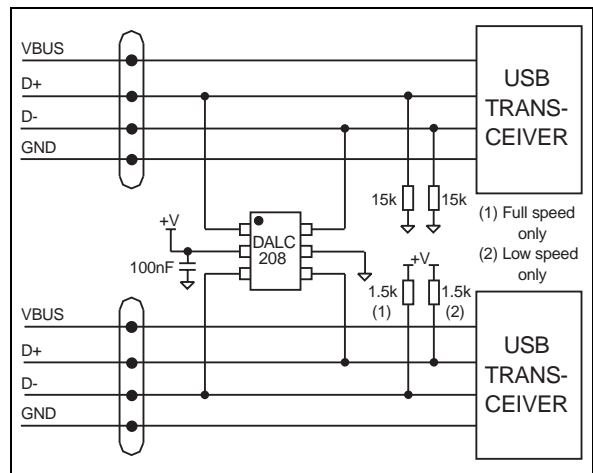

■ Another way to connect the DALC208SC6

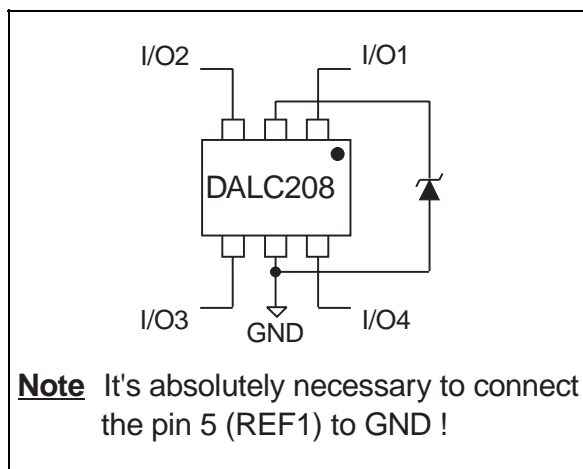

PSPICE MODEL

Fig. A11: PSpice model of one DALC208SC6 cell.

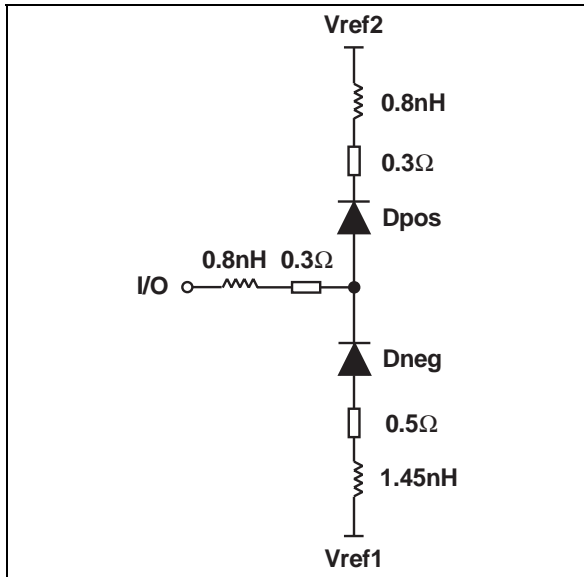

Figure A11 shows the PSpice model of one DALC208SC6 cell. In this model, the diodes are defined by the PSpice parameters given in table below (Fig A12).

Fig. A12: PSpice parameters.

	DPOS	DNEG
BV	9	9
CJO	7p	7p
IBV	1u	1u
IKF	28.357E-3	1000
IS	118.78E-15	5.6524E-9
ISR	100E-12	472.3E-9
M	0.3333	0.3333
N	1.3334	2.413
NR	2	2
RS	0.68377	0.71677
VJ	0.6	0.6

Note: This simulation model is available only for an ambient temperature of 27°C.

The simulations done (Fig. A13, A14, A15) shows that the PSpice model is close to the product behavior.

Fig. A13a: PSpice model simulation: surge > 0 IEC 1000-4-2 contact discharge response.

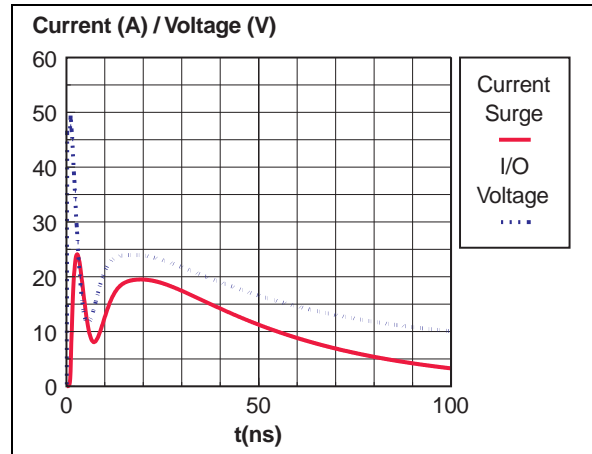

Fig. A13b: PSpice model simulation: surge < 0 IEC 1000-4-2 contact discharge response.

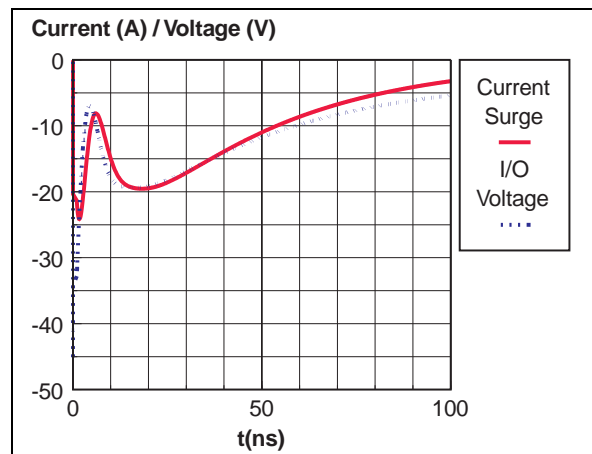
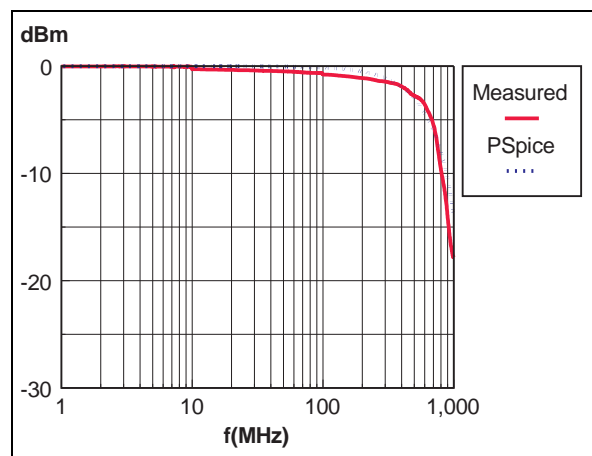

Fig. A14: Attenuation comparison.



DALC208SC6

MARKING

Type	Marking	Order Code	Packaging (Base Qty)
DALC208SC6	DALC	DALC208SC6	tape & reel (3000)

PACKAGE MECHANICAL DATA

SOT23-6L (Plastic)

REF.	DIMENSIONS					
	Millimeters			Inches		
	Min.	Typ.	Max.	Min.	Typ.	Max.
A	0.90		1.45	0.035		0.057
A1	0		0.15	0		0.006
A2	0.90		1.30	0.035		0.0512
b	0.35		0.50	0.0137		0.02
C	0.09		0.20	0.004		0.008
D	2.80		3.00	0.11		0.118
E	1.50		1.75	0.059		0.0689
e		0.95			0.0374	
H	2.60		3.00	0.102		0.118
L	0.10		0.60	0.004		0.024
M			10°			10°

FOOTPRINT DIMENSIONS (in millimeters)

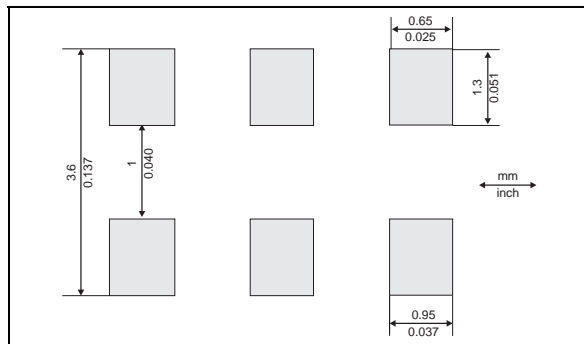

Information furnished is believed to be accurate and reliable. However, STMicroelectronics assumes no responsibility for the consequences of use of such information nor for any infringement of patents or other rights of third parties which may result from its use. No license is granted by implication or otherwise under any patent or patent rights of STMicroelectronics. Specifications mentioned in this publication are subject to change without notice. This publication supersedes and replaces all information previously supplied. STMicroelectronics products are not authorized for use as critical components in life support devices or systems without express written approval of STMicroelectronics.

The ST logo is a registered trademark of STMicroelectronics

© 1999 STMicroelectronics - Printed in Italy - All rights reserved.

STMicroelectronics GROUP OF COMPANIES

Australia - Brazil - Canada - China - France - Germany - Italy - Japan - Korea - Malaysia - Malta - Mexico - Morocco - The Netherlands - Singapore - Spain - Sweden - Switzerland - Taiwan - Thailand - United Kingdom - U.S.A.

<http://www.st.com>