

DFC6 SERIES SINGLE OUTPUT

DESCRIPTION

Designed for digital, ECL, and analog application, the DFC6 Series will provide up to 6 watts in an industry standard package. Ultra-wide range input voltage allows operation from battery power as well as system power. The output is electrically isolated, thereby allowing the output to be configured as a positive or negative output voltage. Fully isolated and filtered outputs permit usage in sensitive and low noise circuits. The 100KHz operating frequency of the DFC6 Series allows an increased power density while including adequate heat sinking and input/output filtering. This eliminates the need for external components in most applications.

FEATURES

- Ultra-Wide 3.5 to 16 Volt Input Range
- Input Filtered
- 6 Watts of Output Power
- Efficiencies to 77%
- 700V Isolation
- Low Input to Output Capacitance
- Ultra-Wide Input Range (4:1)

| Selection Chart | | | | |
|-----------------|---------------------|-----|------------|-----------|
| Model | Input Range VDC (4) | | Output VDC | Output mA |
| | Min | Max | | |
| DFC6U5S5 | 3.5 | 16 | 5 | 1200 |
| DFC6U5S5.2 | 3.5 | 16 | 5.2 | 1200 |
| DFC6U5S12 | 3.5 | 16 | 12 | 500 |
| DFC6U5S15 | 3.5 | 16 | 15 | 400 |

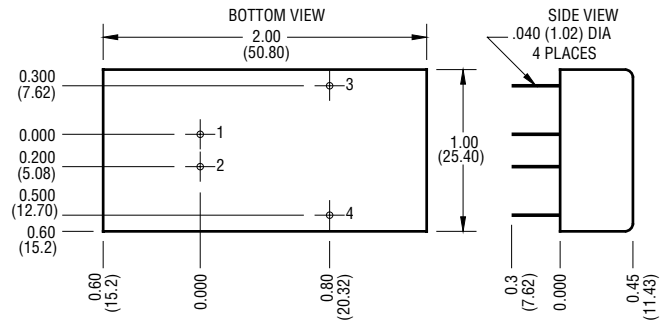

| General Specifications (1) | | | |
|--|------------|------------|---------|
| All Models | | | Units |
| Isolation | | | |
| Isolation Voltage Input to Output 10µA Leakage | MIN | 700 | VDC |
| Input to Output Capacitance | TYP | 300 | pF |
| Environmental | | | |
| Case Operating Range, Tc No Derating | MIN MAX | -40 85 | °C |
| Case Functional Range (2) | MIN MAX | -50 100 | °C |
| Storage Range | MIN MAX | -55 105 | °C |
| Thermal Impedance (3) | TYP | 19 | °C/Watt |
| General | | | |
| MTBF (Calculated) | TYP | 800,000 | HRS |
| Unit Weight | TYP | 0.9 / 25.6 | oz / gm |
| Chassis Mounting Kit | CM2B1 | | |

Mechanical tolerances unless otherwise noted:

- X.XX dimensions: ±0.020 inches
- X.XXX dimensions: ±0.005 inches

| Pin | Function |
|-----|----------|
| 1 | +INPUT |
| 2 | -INPUT |
| 3 | +OUT |
| 4 | -OUT |

NOTES

- (1) All parameters measured at Tc=25°C, nominal input voltage and full rated load unless otherwise noted. Refer to the Technical Reference Section for the definition of terms, measurement circuits and other information.
- (2) The functional temperature range is intended to give an additional data point for use in evaluating this power supply. At the low functional temperature the power supply will function with no side effects, however, sustained operation at the high functional temperature will reduce expected operational life. The data sheet specifications are not guaranteed beyond the case operating range.
- (3) The case Thermal Impedance is specified as the case temperature rise over ambient per package dissipated.
- (4) Reduced output power available with 3.5V input. Full power is available above 4.6V input. See input voltage derating curve for more information



DFC6 SERIES – SINGLE OUTPUT

| Input Parameters (1) | | | | | | |
|---|-----------|----------|------------|-----------|-----------|-------|
| Model | | DFC6U5S5 | DFC6U5S5.2 | DFC6U5S12 | DFC6U5S15 | Units |
| Voltage Range (2) | MIN | 3.5 | | | | VDC |
| | MAX | 16 | | | | |
| Input Current | Full Load | 1680 | 1750 | 1680 | 1670 | mA |
| | No Load | 10 | 10 | 10 | 20 | |
| Switching Frequency | TYP | 100 | | | | kHz |
| Maximum Input Overvoltage, 100ms Maximum | MAX | 20 | | | | VDC |
| Turn-on Time, 1% Output Error | TYP | 10 | | | | ms |

| Output Parameters (1) | | | | | | |
|---|-----|--------------------------|------------|-----------|-----------|-------------------|
| Model | | DFC6U5S5 | DFC6U5S5.2 | DFC6U5S12 | DFC6U5S15 | Units |
| Output Voltage | | 5 | 5.2 | 12 | 15 | VDC |
| Output Voltage Accuracy | MIN | 4.95 | 5.15 | 11.900 | 14.900 | VDC |
| | TYP | 5.00 | 5.20 | 12.000 | 15.000 | |
| | MAX | 5.05 | 5.25 | 12.100 | 15.100 | |
| Rated Load Range (5) | MIN | 0 | 0 | 0 | 0 | mA |
| | MAX | 1200 | 1200 | 500 | 400 | |
| Load Regulation 25% Max Load - Max Load | TYP | 0.3 | 0.3 | 0.1 | 0.1 | % |
| | MAX | 0.7 | 0.7 | 0.5 | 0.5 | |
| Line Regulation Vin = Min-Max VDC | TYP | 0.1 | | | | % |
| | MAX | 0.2 | | | | |
| Short Term Stability (4) | TYP | < 0.05 | | | | %/24Hrs |
| Long Term Stability | TYP | < 0.1 | | | | %/kHrs |
| Noise, Peak - Peak (3) RMS Noise | TYP | 75 | 75 | 50 | 40 | mV _{pp} |
| | TYP | 20 | 20 | 10 | 8 | mV _{rms} |
| Temperature Coefficient | TYP | 50 | | | | ppm/°C |
| | MAX | 150 | | | | |
| Short Circuit Protection to Common for all Outputs | | Short Term Current Limit | | | | |

NOTES

- (1) All parameters measured at Tc=25°C, nominal input voltage and full rated load unless otherwise noted. Refer to the Technical Reference Section for the definition of terms, measurement circuits and other information.
- (2) Reduced output power available at 3.5V input. Full output power is available above 4.6V input. See input voltage derating curve for more information.
- (3) Noise is measured per Technical Reference Section. Measurement bandwidth is 0-20 MHz for peak-peak measurements, 10 kHz to 1 MHz for RMS measurements. Output noise is measured with a 1µF/35V Tantalum capacitor located 1" away from the converter to simulate PCB standard decoupling.
- (4) Short term stability is specified after a 30 minute warmup at full load, constant line and recording the drift over a 24 hour period.
- (5) No minimum load required for operation. Dynamic regulation may degrade when run with less than 5% load.

DFC6 SERIES APPLICATION NOTES:

External Capacitance Requirements

No external capacitance is required for operation of the DFC6 Series. To meet the reflected ripple requirements of the converter, an input impedance of less than 0.15 Ohms from DC to 200KHz is required. If a capacitive input source is farther than 1" from the converter, an additional capacitor may be required at the input pins for proper operation. External output capacitance is not

required for operation, however it is recommended that 1µF to 10µF of tantalum and 0.001 to 0.1µF ceramic capacitance be selected for reduced system noise. Additional output capacitance may be added for increased filtering, but should not exceed 400µF.

Output Power

The available output power of the DFC6 Series is reduced when operating below 4.6 volts. See Input Voltage Derating curve. Below 4.6 volts the output power is linearly derated from 100% at 4.6 volts to 50% at 3.5 volts.

Negative Outputs

A negative output voltage may be obtained by connecting the +OUT to circuit ground and connecting -OUT as the negative output.

DFC6 SERIES – SINGLE OUTPUT

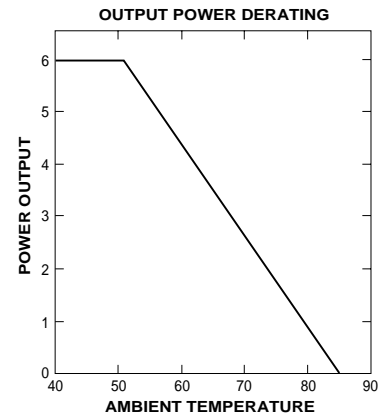
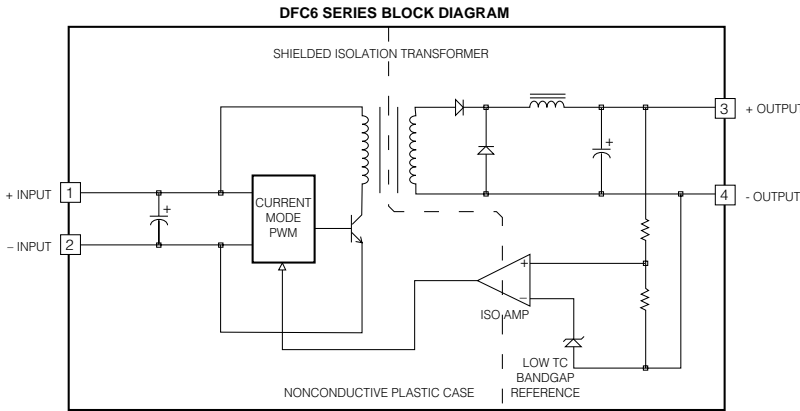

Typical Performance: (Tc=25°C, Vin=Nom VDC, Rated Load)

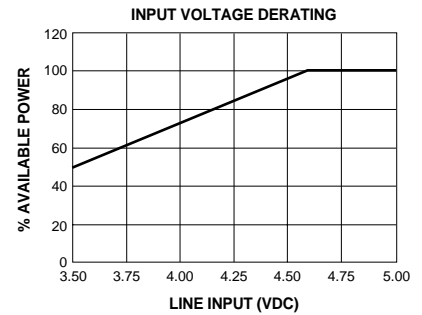
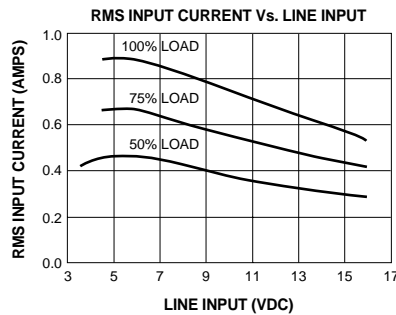
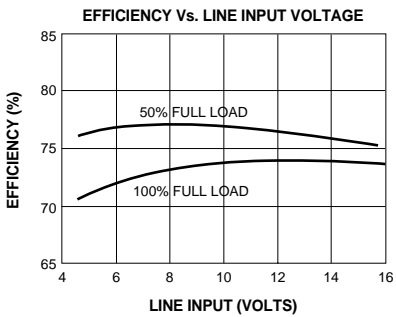
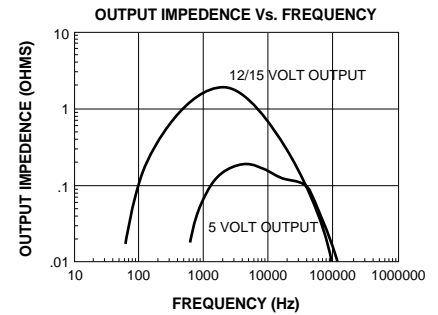
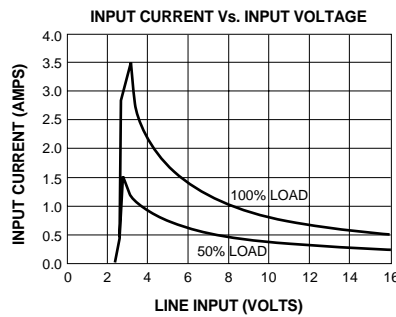
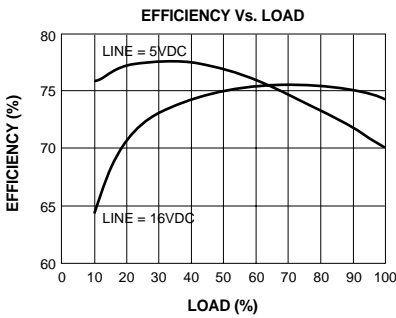

For the Most Up-To-Date Information

www.power-one.com

24 Hours/Day—7 Days/Week

NUCLEAR AND MEDICAL APPLICATIONS Power-One products are not authorized for use as critical components in life support systems, equipment used in hazardous environments, or nuclear control systems without the express written consent of the President of Power-One, Inc.

TECHNICAL REVISIONS The appearance of products, including safety agency certifications pictured on labels, may change depending on the date manufactured. Specifications are subject to change without notice.