

DRAN I 20 SERIES



DC BACKUP SYSTEM
 AC - DC DIN RAIL MOUNTABLE
 120W
 INDUSTRIAL CONTROL EQUIPMENT

FEATURES

- COMPACT DESIGN
- SIMPLE IN APPLICATION
- LOW PRICING
- WORKABLE FOR BOTH POWER SUPPLY / DC BACKUP SYSTEM
- INPUT VOLTAGE 115/230VAC AUTO SELECT

SELECTION CHART

DRAN I 20 - 24 A *

Wattage | DC Backup System | SCREW TERMINALS

12 : 13.6VOUT
 24 : 27.2VOUT
 48 : 54.5VOUT

MODEL LIST

MODEL NO.	INPUT VOLTAGE	OUTPUT WATTAGE	OUTPUT VOLTAGE	OUTPUT CURRENT	EFF. (min.)	EFF. ⁽¹⁾ (typ.)
-----------	---------------	----------------	----------------	----------------	-------------	----------------------------

Single Output Models

DRAN I 20-12A*	115 / 230 VAC	120 WATTS	+ 13.6 VDC	9A	82%	84%
DRAN I 20-24A*	115 / 230 VAC	120 WATTS	+ 27.2 VDC	4.4A	84%	86%
DRAN I 20-48A*	115 / 230 VAC	120 WATTS	+ 54.5 VDC	2.2A	85%	87%

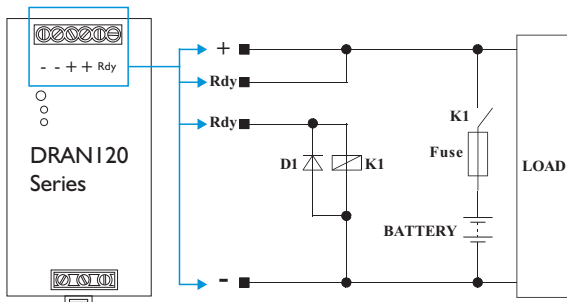

DRAN I 20 Series For DC Backup System Application

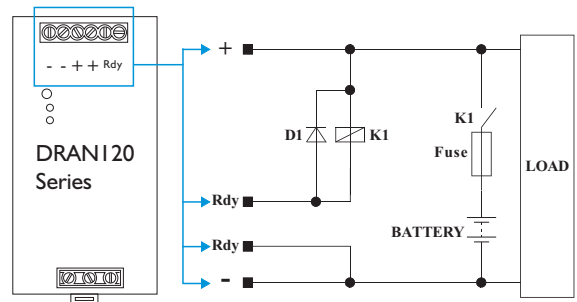

DRAN I 20 Series For DC Backup System Application

Note :

1. The suffix "A*" is part of the model number, which specifies the product is designed and pre-trim for low-cost DC backup power system with external Lead-Acid battery, Relay and Fuse.
2. The manufacturer is liable neither for the external components nor the damage to the power supply causing by external components.
3. The total consumption current including loading and battery charging current should not exceed the maximum rated current of power supply.
4. The operation concept of DC backup power system :
 - A. When AC power alive : The "Rdy" is close circuit to active the external Relay . The power supply feeds current into the external loads and charges through Relay to the external battery as well.
 - B. When AC power interrupted : The "Rdy" is remain close circuit to maintain the external Relay remain active, the external battery supply current to the external loads.
 - C. When Battery power low : The "Rdy" become open circuit and the external Relay become inactive to disconnect the battery from external loads.

SPECIFICATION

All Specifications Typical At Nominal Line, Full Load, 25°C Unless Otherwise Noticed

GENERAL

Characteristics	Conditions	min.	typ.	max.	unit
Isolation voltage	Input / Output	3,000			VAC
Isolation resistance	Input / Output, @ 500VDC	100			MΩ
Ambient temperature	Operating at Vi nom	-25		+ 71	°C
Derating	Vi nom, from +61 to +71°C			2.5	% / °C
Storage temperature	Non operational	-25		+ 85	°C
Relative humidity	Vi nom, lo nom	20		95	% RH
Dimension	Screw terminal type	L125 x W63.5 x D123.6			mm
Cooling	Free air convection				mm
Case material	Metal				

INPUT SPECIFICATIONS

Characteristics	Conditions	min.	typ.	max.	unit
Rated input voltage	lo nom	115 / 230 (auto select)			VAC
Input voltage range	Ta min ... Ta max, AC	115V selected	90	132	VAC
		230V selected	186	264	VAC
		DC	210	370	VDC
Rated input current	lo nom		2.8 / 1.4		A
Line frequency	Vi nom, lo nom	47		63	Hz
Inrush current	Vi nom, lo nom	Vi : 115VAC		24	A
		Vi : 230VAC		48	A
P.F.C.	Vi : 230VAC, lo nom		0.7		

OUTPUT SPECIFICATIONS

Characteristics	Conditions	min.	typ.	max.	unit
Output voltage accuracy (Adjusted before shipment)	Vi nom, lo max	-0		+ 1	%
Minimum load	Vi nom	0			%
Line regulation	lo nom, Vi min ... Vi max			± 0.5	%
Load regulation	Vi nom, lo min ... lo nom			± 1	%
Temperature coefficient	Vi nom, lo min			± 0.3	% / °C
Ripple & noise	Vi nom, lo nom, BW = 20MHz			50	mV
Hold up time	Vi nom, lo nom	Vi = 115VAC	25		ms
		Vi = 230VAC	30		ms
Voltage trim range	Vi nom, lo nom	12V models	11.4	14.5	VDC
		24V models	22.5	28.5	VDC
		48V models	45	55	VDC
Rdy Close / DC ON indicator threshold at start up	Vi nom, lo nom	12V models	10.4	11.4	VDC
		24V models	21.2	22.2	VDC
		48V models	42.8	43.8	VDC
Rdy Open / DC LOW indicator threshold after start up	Vi nom, lo nom	12V models	10.3	11.3	VDC
		24V models	21.1	22.1	VDC
		48V models	42.7	43.7	VDC

SPECIFICATION

All Specifications Typical At Nominal Line, Full Load, 25°C Unless Otherwise Noticed

CONTROL AND PROTECTION

Characteristics	Conditions	min.	typ.	max.	unit
Input fuse		T3.15A / 250VAC internal			
Rated over load protection	V_i nom	105		125	%
Over voltage protection	V_i nom, I_o nom	125		145	%
Output short circuit	V_i nom, I_o nom	Current limited			

APPROVALS AND STANDARDS

UL / cUL	UL508 Listed, UL60950-I Recognized
TUV	EN60950-1
CE	EN61000-6-3, EN55022 class B, EN61000-3-2, EN61000-3-3 EN61000-6-2, EN55024

CIRCUIT SCHEMATIC

• Block diagram for DRAN120 series

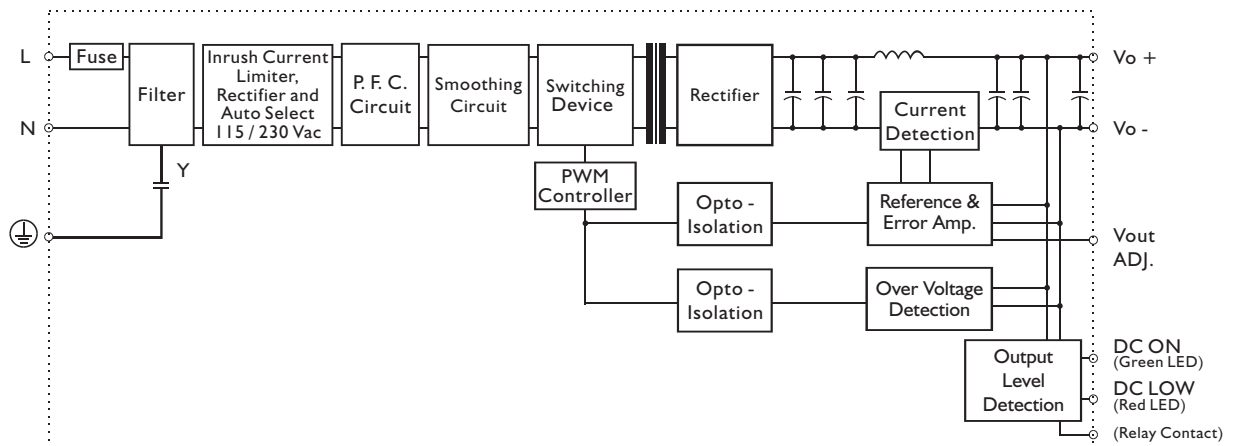

PHYSICAL CHARACTERISTICS

CASE SIZE	
SCREW TERMINAL TYPE	125 x 63.5 x 123.6 mm 4.92 x 3.27 x 4.87 inches
WEIGHT	920g

MECHANISM & PIN CONFIGURATION

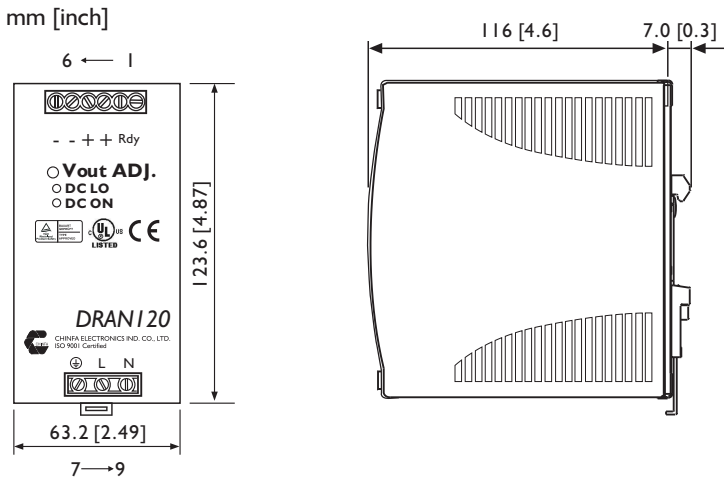

CONSTRUCTION

Easy snap-on mounting onto the DIN-Rail (TS35/7.5 or TS35/15), unit sits safely and firmly on the rail.

INSTALLATION

Ventilation / Cooling

Normal convection

All sides 25m/m free space

For cooling recommended

Connector size range

Screw terminal:

10-24AWG flexible / solid cable,

8 m/m stripping at cable end recommends

Detachable connector:

14-24AWG flexible / solid cable,

7 m/m stripping at cable end recommends

PIN ASSIGNMENT

PIN NO.	Designation	Description
1	RDY	A normal open relay contact for DC ON level control (Never connect except 24V model)
2		
3	V +	Positive output terminal
4	V +	Positive output terminal
5	V -	Negative output terminal
6	V -	Negative output terminal
7	⊕	Ground this terminal to minimize high-frequency emissions
8	L	Input terminals (phase conductor, no polarity at DC input)
9	N	Input terminals (neutral conductor, no polarity at DC input)
	DC ON	Operation indicator LED
	DC LO	DC LOW voltage indicator LED
	Vout ADJ.	Trimmer-potentiometer for Vout adjustment

DERATING

