

FEATURES

- Real-time clock (RTC)/calendar in binary-coded decimal (BCD) format counts seconds, minutes, hours, date, month, day of the week, and year with leap-year compensation and is year 2000-compliant
- Logs up to 1025 consecutive events in read-only nonvolatile (NV) memory
- The event trigger is user-programmable and can be triggered by the falling edge, rising edge, or rising and falling edges of the $\overline{\text{INT}}$ pin
- Event count register provides data on the number of events that have been logged in the current event logging mission
- Programmable real-time clock alarm
- 32-byte, battery-backed, NV RAM for data storage
- Two-wire serial interface allows for a simple connection to your system
- Three resolution options are available to trade off accuracy versus maximum time between events
- Underwriters Laboratory (UL) recognized

ORDERING INFORMATION

DS1678	8-Pin DIP (300-mil)
DS1678S	8-Pin SOIC (208-mil)

PIN ASSIGNMENT

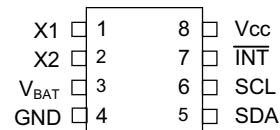

8-Pin DIP (300-mil)
8-Pin SOIC (208-mil)

Package dimension information can be found at:
<http://www.maxim-ic.com/TechSupport/PackInfo.htm>

PIN DESCRIPTION

- | | |
|-------------------------|--------------------------|
| V _{BAT} | - Battery Supply |
| X1 | - Crystal Input |
| X2 | - Crystal Output |
| $\overline{\text{INT}}$ | - Interrupt Input/Output |
| GND | - Ground |
| SDA | - 2-wire Input/Output |
| SCL | - 2-wire Clock Input |
| V _{CC} | - +5V Supply |

TYPICAL OPERATING CIRCUIT

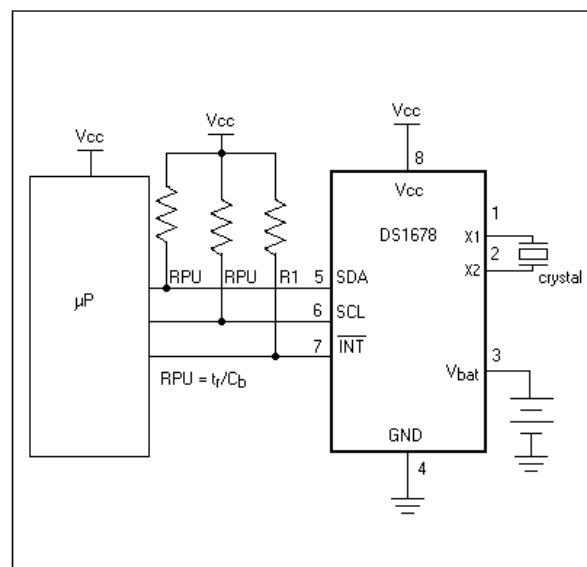

DESCRIPTION

The DS1678 Real-Time Clock Event Recorder records the time and date of a non-periodic, asynchronous event each time the $\overline{\text{INT}}$ pin is activated. The device records the seconds, minutes, hours, date, day of the week, month, year, and century when the first event occurs. Subsequent events trigger the recording of the 16-bit elapsed time counter (ETC) into the 2048 bytes of event log memory. This allows for up to 1025 events to be logged.

The event count register contains the total number of events that have been logged in the current event-logging mission. The event count register also allows the user to determine if the data in the event log memory has rolled over.

Three resolution options allow users to maximize the event log resolution while providing an adequate maximum time between events without using extra memory locations based on the specific characteristics of the event being logged. The seconds resolution provides the time of an event down to the second while allowing up to 18.2 hours between events without using extra memory locations. The minutes resolution provides the time of an event down to the minute while allowing up to 45.5 days between events without using extra memory locations. The hours resolution provides the time of an event down to the hour in which it occurred, while allowing up to 7.5 years between events without using extra memory locations. Based on the expected frequency of events, the correct setting can be easily selected to maximize the resolution and memory utilization.

The event can be triggered in three different ways depending on how the user programs the trigger select (TRx) bits in the control register. The event can be triggered by a falling edge on the $\overline{\text{INT}}$ pin only, a rising edge only, or it can be triggered by rising and falling edges. Triggering with both the rising and falling edges allows for monitoring when something is turned on/off and how long it is in either state.

The RTC provides seconds, minutes, hours, day, date, month, and year information with leap-year compensation, year 2000-compliance, and also provides an alarm interrupt. The 2-wire interface allows the RTC to function as a stand alone RTC in the system.

The programmable alarm trip points in the RTC will allow a flag to be set in the control register when the specified time in the alarm trip point register is reached. The flag is readable via the 2-wire interface during an event logging mission or, when the DS1678 is not in a mission, the $\overline{\text{INT}}$ pin will become an output and generate an alarm interrupt if the value in the RTC equals the value in the RTC alarm register and the duration interval select (DISx) bits are both set to zeros.

The DS1678 operates as a slave device on the 2-wire serial bus. Access is obtained by implementing a START condition and providing a device identification code followed by a register address. All data is transferred to and from the DS1678 most significant bit (MSB) first. The address counter will automatically increment so that subsequent registers can be accessed sequentially until a STOP condition is executed. When V_{CC} falls below $1.25 \times V_{BAT}$ the device automatically write protects itself, terminates any access in progress and resets the device address counter. Inputs to the device via the 2-wire bus will not be recognized at this time to prevent erroneous data from being written to the device from an out of tolerance system. When V_{CC} falls below V_{BAT} the device switches into a low-current battery backup mode. Upon power-up, the device switches from battery power to V_{CC} when V_{CC} is greater than $V_{BAT} + 0.2V$ and recognizes inputs from the system when V_{CC} is greater than $1.25 \times V_{BAT}$ by releasing control of the write protection on the 2-wire bus.

The block diagram in Figure 1 shows the main elements of the RTC event recorder. The device has four major components: 1) 64-bit RTC and control block, 2) 32-byte user NV RAM, 3) 2048 bytes of event log memory (1024 events), and 4) 2-wire serial interface.

DS1678 BLOCK DIAGRAM Figure 1

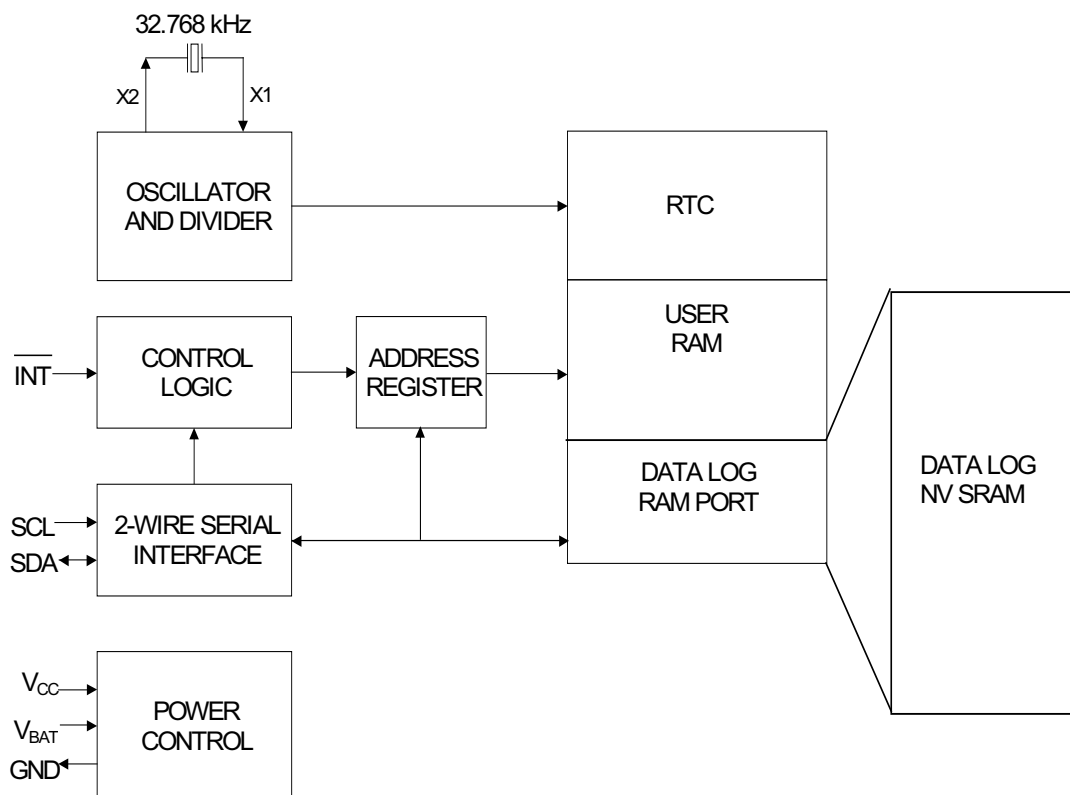

SIGNAL DESCRIPTIONS

The following paragraphs describe the function of each pin.

V_{CC} – V_{CC} is a +5V input supply. Communication with the DS1678 can take place only when V_{CC} is connected to a +5V supply.

V_{BAT} – Battery input for standard lithium cell or other energy source. All functions of the DS1678 with the exception of the serial interface circuitry are powered by V_{BAT} when V_{CC} < V_{BAT}. All functions are powered by V_{CC} when V_{CC} > V_{BAT}. If a battery or other energy source is not used, V_{BAT} should be connected directly to ground. UL recognized to ensure against reverse charging current when used in conjunction with a lithium battery.

See “Conditions of Acceptability” at <http://www.maxim-ic.com/TechSupport/QA/ntrl.htm>.

GND – Ground.

SCL (2-Wire Serial Clock Input) – The SCL pin is the serial clock input for the 2-wire synchronous communications channel. The SCL pin is an open drain input, which requires an external pull-up resistor.

SDA (2-Wire Input/Output) – The SDA pin is the data input/output (I/O) signal for the 2-wire synchronous communications channel. The SDA pin is an open drain I/O, which requires an external pull-up resistor.

$\overline{\text{INT}}$ (Interrupt Input/Output) – The $\overline{\text{INT}}$ pin is an I/O that will be activated by an external device to signify an event has occurred and should be logged. Once the pin is activated, the event will be recorded in the event log memory and the event counter register will be incremented by one.

The $\overline{\text{INT}}$ pin can be activated in three different ways depending on how the user programs the TRx bits. The event can be triggered by a falling edge on the $\overline{\text{INT}}$ pin only, a rising edge only, or it can be triggered by both the rising and falling edges. By logging both the rising and falling edges as events, the time when something is turned on and turned off can be determined and the amount of time that the external system was in either state.

This assumes that the external system always starts logging data in a known state. For example, if a light switch is being monitored and the switch is always in the off position before a mission is started, the first event would be turning the lights on. The next event would have to be to turn the lights off. The time between the events would be the amount of time the lights were in the on state. The time from turning the lights off until the next event, which would be to turn the lights back on again, would be the amount of time the lights were off.

The $\overline{\text{INT}}$ pin can also be used as an output when the DS1678 is not in an event logging mission. The $\overline{\text{INT}}$ pin will become an output and generate an alarm interrupt if the DISx bits are both set to zero and the RTC reaches the preset value in the alarm register. The $\overline{\text{INT}}$ output remains low as long as the status bit causing the interrupt is present and the DISx bits are both set to zero.

The $\overline{\text{INT}}$ pin is an open-drain input/output with a weak internal pull-down resistor to prevent the pin from floating if the signal connected to the pin is tri-stated. Without the resistor, the input would float and potentially log phantom events. With the pull-down resistor, the pin can be transitioned to a low state causing an event to be recorded if the $\overline{\text{INT}}$ pin was being held high by an outside signal that becomes tri-stated.

X1, X2 – Connections for a standard 32.768kHz quartz crystal, Daiwa part number DT-26S or equivalent. For greatest accuracy, the DS1678 must be used with a crystal that has a specified load capacitance of 12.5pF. There is no need for external capacitors or resistors. Note: X1 and X2 are very high impedance nodes. It is recommended that they and the crystal be guard-ringed with ground and that high frequency signals be kept away from the crystal area. For more information on crystal selection and crystal layout considerations, please consult Application Note 58, “Crystal Considerations with Dallas Real-Time Clocks.”

RECOMMENDED LAYOUT FOR CRYSTAL

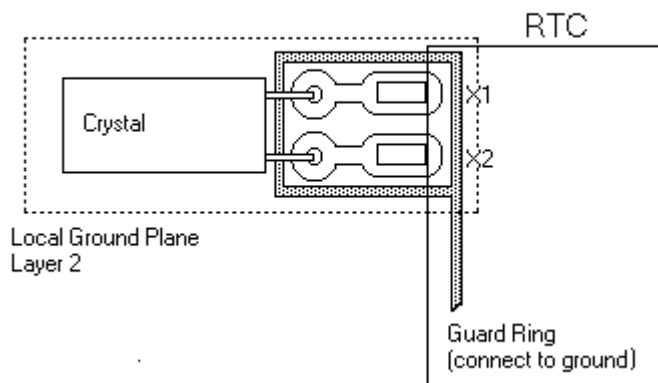

CLOCK ACCURACY

The accuracy of the clock is dependent upon the accuracy of the crystal and the accuracy of the match between the capacitive load of the oscillator circuit and the capacitive load for which the crystal was trimmed. Additional error will be added by crystal frequency drift caused by temperature shifts. External circuit noise coupled into the oscillator circuit may result in the clock running fast. See Application Note 58, “Crystal Considerations with Dallas Real-Time Clocks” for detailed information.

MEMORY

The memory map in Figure 2a shows the general organization of the DS1678. As can be seen in the figure, the device memory is in one contiguous segment with a data port to access the event log memory. Since the 2-wire bus only has the capability to use one byte addressing, the DS1678 utilizes the data port to access the 2048 bytes of event log memory. The address that the next data will be written to is stored in the address pointer registers LSB (3Fh) and MSB (40h). These will be helpful in recovering all of the data if a rollover occurs. The address pointer will point to the oldest event in the memory after a rollover. This is the memory location in event log memory that would be over written by the next event. Read the data from this point to the end of the memory and the start time stamp, including the 2-byte ETC from last event. Working backward from the value in the start time stamp, subtract the value in the ETC from last event to get the time the last event in the memory occurred. Then subtract the values in each of the 2-byte memory locations for elapsed time between events in order to recover the time the previous event occurred.

The value in the ETC register LSB (3Dh) and MSB (3Eh) is the value in the actual ETC. This is the time from the last event recorded until logging was stopped. Since a new event has not occurred, this data has not been stored in the event memory yet.

The data port is made up of three bytes. The first byte (41h) is the event log memory address LSB, the second byte (42h) is the event log memory address MSB, and the third byte (43h) is the event log memory data byte. To access data via the data port, the LSB of the event log memory address is written into 41h, the main memory address pointer will automatically increment to 42h where the event log memory address MSB data will be written. The next transfer will indicate a read command with a 1 in the R/\overline{W} bit of the 2-wire address byte. The data from the event log memory location corresponding to the address written into main memory locations 41h and 42h will be available in location 43h to be read. Any address greater than 43h will read back 00h and will not be able to be written. For address above 43h, the address pointer will increment until it reaches FFh then rollover to 00h.

The event log memory address pointer in main memory locations 41h and 42h will be auto-incremented to the next higher event log memory address, while the pointer for the main memory will remain at location 43h. This will allow the event log memory to be read continuously without having to write the next desired event log memory location prior to each data read. The even address locations in the event log memory will correspond to the LSB of the elapsed time between events and the odd memory locations will correspond to the MSB of the elapsed time between events. For more information about how the data is stored in the event log memory, see Figure 2b.

When the event log memory address pointer gets to the last address location (07FFh), the automatic incrementing will stop. A new starting address will then have to be written into the event log memory pointer bytes (41h & 42h) in order to begin reading additional data. The event log memory addresses that can be put into the pointer (41h & 42h) are 0000h to 07FFh. The five MSB of the address are ignored.

Entering a value greater than 07FFh will result in the address location associated with the value of the lowest 11 bits of the address.

The RTC and control registers (See Figure 2a for more detail.) are located in the main memory between addresses 00h and 0Fh. The user NV RAM resides in locations 10h through 2Fh. The event logging memory data port is located at locations 41h, 42h, and 43h. Memory locations 44h and up are reserved for future extensions and will read 00h.

The end user can write only to the RTC and control registers and the user NV RAM. The rest of the memory map is read-only from the end user's perspective. During an event log mission, all of the memory is read only. A write will terminate the mission. If there is an event being recorded when the mission is terminated, the event will finish being recorded before the mission will be stopped and the values in the MIP and ME bits will not change to 0's until the mission has completed.

During an event log mission, memory locations 30h and above are not accessible to the user to avoid data collisions from a user read and an event being logged at the same time. If the user tries to read a location with an address greater than 2Fh during a mission, the value returned will be 00h.

DS1678 RTC AND CONTROL PAGE Figure 2a

ADDRESS	BIT 7	BIT 6	BIT 5	BIT 4	BIT 3	BIT 2	BIT 1	BIT 0	FUNCTION	
00	0	10 SECONDS			SECONDS					RTC
01	0	10 MINUTES			MINUTES					
02	0	12/24	AM/PM 10 HR	10 HR	HOUR					
03	0	0	0	0	0	DAY OF WEEK				
04	0	0	10 DATE		DATE					
05	0	0	0	10 MO	MONTH					
06	10 YEAR				YEAR					
07	10 CENTURY				CENTURY					
08	MS	10 SECONDS ALARM			SECONDS ALARM					RTC Alarm
09	MM	10 MINUTES ALARM			MINUTES ALARM					
0A	MH	12/24	AM/PM 10 HR	10 HR	HOUR ALARM					
0B	MD	0	0	0	0	DAY-OF-WEEK ALARM				
0C	(reads 00h)								Reserved	
0D										
0E	ME	CLR	DIS1	DIS0	RO	TR1	TR0	COE	Control	
0F	0	MEM CLR	MIP	CM	LOBAT	ROF	0	ALMF	Status	
10 11 12 ↓ 2F	Byte 1 Byte 2 Byte 3 ↓ Byte 32								User-Programmable NV Memory	
30	0	10 SECONDS			SECONDS					Time Stamp And Elapsed Time Counter
31	0	10 MINUTES			MINUTES					
32	0	12/24	AM/PM 10 HR	10 HR	HOURS					
33	0	0	0	0	0	DAY-OF-WEEK				
34	0	0	10 DATE		DATE					
35	0	0	0	10 MO	MONTH					
36	10 YEAR				YEAR					
37	10 CENTURY				CENTURY					
38	Event 0 Elapsed Time from last Event Counter LSB									
39	Event 0 Elapsed Time from last Event Counter MSB									
3A	Low byte								Event Count	
3B	Medium Byte									
3C	High Byte									
3D	Low Byte								Elapsed Time Counter (ETC)	
3E	High Byte									
3F	Low Address Byte								Address Pointer	
40	High Address Byte									
41	Low Address Byte								Data Log RAM Port	
42	High Address Byte									
43	Data Byte									
44 ↓ FF	(reads 00h)								Reserved	

DS1678 EVENT ELAPSED TIME DURATION Figure 2b

ADDRESS	REGISTER
0000	Event 1 Elapsed Time from Last Event Counter LSB
0001	Event 1 Elapsed Time from Last Event Counter MSB
0002	Event 2 Elapsed Time from Last Event Counter LSB
0003	Event 2 Elapsed Time from Last Event Counter MSB
0004	↓
↓	
07FB	
07FC	Event 1023 Elapsed Time from Last Event Counter LSB
07FD	Event 1023 Elapsed Time from Last Event Counter MSB
07FE	Event 1024 Elapsed Time from Last Event Counter LSB
07FF	Event 1024 Elapsed Time from Last Event Counter MSB

EVENT LOGGING

When the DS1678 event logging function is enabled, the device is said to be on an “event log mission” until the event logging is stopped.

An event can be triggered one of three ways depending on the settings of the TRx bits in the control register. With TR0 bit set to a 1 and TR1 bit set to a 0, the $\overline{\text{INT}}$ signal will be activated on the falling edge of the input signal. With the TR0 bit set to a 0 and the TR1 bit set to a 1, the $\overline{\text{INT}}$ pin will be activated on the rising edge of the input signal. With both TR0 and TR1 bits set to 1, the $\overline{\text{INT}}$ pin will be activated on both the falling and rising edges to allow for the measurement of on/off type events and their duration's. If TR0 and TR1 are both set to 0, nothing will happen when the $\overline{\text{INT}}$ pin is toggled and a mission will not start. This is an illegal state and the mission will not start without a valid value in the TRx bits prior to attempting to start the mission.

During an event log mission, every time the $\overline{\text{INT}}$ pin is activated, the elapsed time from the last event is written to the event log memory pages. These memory pages are accessible through the data port in the main memory. To access data via the data port, the LSB of the address location in the event log memory is written into 41h, the main memory address pointer will automatically increment to 42h where the event log memory address MSB data will be written. The data from the event log memory location corresponding to the address written into main memory locations 41h and 42h will be available in location 43h to be read. The event log data is located at addresses 0000h to 07FFh in the event log memory. The LSB of the first event duration is written to address location 0000h. The MSB of the first event duration is written to address location 0001h. The LSB of the second event is written to address location 0002h. The MSB of the second event duration is written to address location 0003h (see figure 2b for more details). Likewise, the address is incremented with each additional event duration. A total of 2048 registers have been reserved for event log data, which will allow 1024 events to be logged.

A event log mission can be initiated via two different methods (See Figure 7); by a host writing a 1 to the MIP bit of the status register over the serial interface which automatically sets the mission enable bit in the control register to a 1 or by activating the $\overline{\text{INT}}$ input when the mission enable bit in the control register is set to a one. The elapsed time between events recorded during an event log mission is equal to the value written to the event logger memory multiplied by one second, minute, or hour depending on which one of the three is selected in the DISx bits of the control register. Writing a 0 to the MIP bit in the Status register completes the mission and automatically writes a 0 to the ME bit in the control register

once any events that are being recorded have completed. The value in the MIP and ME bits will remain a 1 until the mission has completed, even if they are written to a 0. Upon initiation of an event log mission by either method, the DS1678 will set the Mission-in-Progress (MIP) bit in the Control register to a one.

It should be noted that the MEM CLR bit of the Status register must be a one in order to start an event log mission. This means that the Event Log memory, the Event Count, Elapsed Time Counter, Address Pointer, and Start Time Stamp registers are cleared of data (all zero's) so that an end user can not turn the logger on and off to avoid recording events. Once the mission is stopped, the memory must be cleared in order to start a new mission.

The time at which the first event log sample is measured is dependent upon the way the mission is started. The first way to start a mission is with a delayed start by writing a 1 to the ME bit. The ME bit will only be able to be written to a 1 if the MEM CLR bit is set to a 1. The mission will have a delayed start until the first event occurs by activating the $\overline{\text{INT}}$ pin. If the mission starts because the ME bit is set to a one and the $\overline{\text{INT}}$ pin is activated, the MIP bit in the status register is set to a one, the current time/date is written to the start time stamp register, the event 0 elapsed time from last event bytes in the time/date stamp are both written with zeros, the event count register will be incremented and the elapsed time counter will start incrementing based on the settings in the DISx bits of the control register. Subsequent events will be logged as the duration of time from the previous event by writing the contents of the ETC into the event log memory when that subsequent event is triggered by the $\overline{\text{INT}}$ pin being activated.

The second way to start a mission is write a 1 to the MIP bit of the status register over the 2-wire interface, which will automatically write a 1 to the ME bit of the control register. This start mission command will be ignored and no action taken if the MEM CLR bit is not set to a 1. When the MIP bit is written to a 1 and the ME bit is set to a 1, the mission is started by loading the current time/date into the start time stamp, the event 0 elapsed time from last event bytes in the time/date stamp are both written with zeros, the event count register will be incremented and the elapsed time counter will start incrementing based on the settings in the DISx bits of the control register. The first event will then be logged as the duration of time since the start time. All subsequent events will then be logged as the duration of time since the previous event.

The user has two options for dealing with the potential occurrence of a data overrun (i.e., more than 1024 total event logs in the event log memory) (See Figure 8). The first option is to enable the rollover feature of the DS1678. This is accomplished by setting the rollover bit (bit 3 of the control register) to 1. When the rollover feature is enabled, new data is written over previous data, starting with the start time stamp register as if a new mission is starting.

The one difference with a time/date stamp from a rollover compared to a new mission start is that the two bytes after the time/date stamp, event 0 elapsed time from last event, will have the elapsed time since event 1024 of the event log memory. This is to allow the user to recover the information recorded prior to the rollover. At the start of a mission, the value in these two bytes will be all zeros since there was no previous event to have an elapsed time from.

The next event will have its elapsed time since the new time/date stamp recorded in event log memory locations 0000h and 0001h as before. For example, if the event log memory has been completely filled (i.e., 1024 event logs have been recorded in the event log memory) the next event will cause a new time/date stamp to be written to the start time stamp register and the elapsed time since event 1024

written to the two event 0 elapsed time from last event registers, the subsequent event log will be written to address locations 0000h and 0001h, and the address pointer will be incremented with each successive data sample. When this rollover occurs, the roll over flag (ROF) in the control register will be set to one to indicate that the memory has rolled over at least one time.

The second option for dealing with data overrun is to simply stop the recording of events after the event log memory has been completely used. In other words, the DS1678 will stop recording event logs after event 1025. More precisely, when the address pointer is incremented from 07FFh to 0000h after the last memory byte is filled with a log, the DS1678 will stop recording events. This feature is enabled by setting the Rollover bit to 0. The device will still continue monitoring the $\overline{\text{INT}}$ pin and the event counter will continue to increment when the $\overline{\text{INT}}$ pin is activated even though the event log memory has been filled.

It should be noted that during an event log mission, a time stamp for the first event is recorded, but is not included for each subsequent event. However, the time of acquisition for any event is easily determined by considering the start time, the value in the event counter register, ROF, and the address of the particular data sample in the event log memory.

If no rollover has occurred in the event log memory (ROF = 0), the sample time associated with any particular data point can be calculated by multiplying the sum of the elapsed time between the events up to that event by one second, minute, or hour depending on which resolution is selected in the DISx bits of the control register, and adding this elapsed time to the value in the start time stamp register.

If the rollover feature has been enabled, the user can determine if rollover has occurred by reading the value in the events counter register or the ROF. The event counter register counts the total number of events that have been acquired. If this value is greater than 0400h (decimal 1025) then the user knows that rollover has occurred. If rollover has occurred, the user needs to determine how many times rollover occurred in determining the sample time for any particular data sample. The address pointer will be pointing to the oldest data in the event log memory and if the memory has rolled over at least one time, the roll over flag will be set to 1.

As a safety measure, the DS1678 has been designed such that the end user cannot write to the event log memory. This prevents the falsification of event log data by writing values to event log registers.

CLOCK, CALENDAR, AND ALARM

The time and calendar information is accessed by reading/writing the appropriate register bytes. Note that some bits are set to zero. These bits will always read zero regardless of how they are written. The contents of the time, calendar, and alarm registers are in the BCD format and are year 2000-compliant.

The DS1678 can run in either 12-hour or 24-hour mode. Bit 6 of the hour's register is defined as the 12- or 24-hour mode select bit. When high, the 12-hour mode is selected. In the 12-hour mode, bit 5 is the AM/PM bit with logic one being PM. In the 24-hour mode, bit 5 is the second 10-hour bit (20–23 hours).

TIME-OF-DAY ALARM BITS Table 1

ALARM REGISTER MASK BITS (bit 7)				
SECONDS (MS)	MINUTES (MM)	HOURS (MH)	DAYS (MD)	
1	1	1	1	ALARM ONCE PER SECOND
0	1	1	1	ALARM WHEN SECONDS MATCH
0	0	1	1	ALARM WHEN MINUTES AND SECONDS MATCH
0	0	0	1	ALARM WHEN HOURS, MINUTES, AND SECONDS MATCH
0	0	0	0	ALARM WHEN DAY, HOURS, MINUTES, AND SECONDS MATCH

The DS1678 also contains a time-of-day alarm. The alarm registers are located in registers 08h to 0Bh. Bit 7 of each of the alarm registers are mask bits (See Table 1). When all of the mask bits are logic 0, an alarm will occur once per week when the values stored in timekeeping registers 00h to 03h match the values stored in the time-of-day alarm registers. An alarm will be generated every day when mask bit of the day alarm register is set to 1. An alarm will be generated every hour when the day and hour alarm mask bits are set to 1. Similarly, an alarm will be generated every minute when the day, hour, and minute alarm mask bits are set to 1. When day, hour, minute, and seconds alarm mask bits are set to 1, an alarm will occur every second.

As a security measure to prevent unauthorized tampering, writing to any memory location or changing any value in the RTC and control registers will stop a event log mission and clear the MIP bit to a 0.

SPECIAL PURPOSE REGISTERS

The following description defines the operation of the special function registers of the DS1678.

CONTROL REGISTER

MSB						LSB	
ME	CLR	DIS1	DIS0	RO	TR1	TR0	COE

ME - Mission Enable – This bit enables the device to begin a mission. The ME bit can not be written to a 1 unless the MEM CLR bit in the Status register is a 1, signifying that the memory and registers have been cleared. With the ME bit set to a one, the device will wait for the first event to occur ($\overline{\text{INT}}$ is activated). Once that first event occurs, the time/date stamp will be recorded in the start time stamp register, the event 0 elapsed time from last event bytes are both written with zeros, the event count register will be incremented, and the elapsed time count will begin incrementing to be ready with the duration of time from the first event until the next event.

When the ME bit is set to logic 0, the DS1678 will wait until a 1 is written to the MIP bit via the 2-wire interface to start the mission. When the MIP bit is written to a 1, the ME bit will be set to a one, the current time/date will be recorded in the start time stamp, the event 0 elapsed time from last event bytes are both written with zeros, the event count register will be incremented, and the elapsed time count will begin incrementing to be ready with the duration of time from the start until the first event.

The ME bit is automatically written to a 0 whenever a mission is stopped.

CLR - Clear Enable – This bit enables the memory to be cleared. When this bit is set to a one and the clear memory (CM) bit in the status register is subsequently written to a 1, the event log memory, event count, and start time stamp registers are all cleared to zeros. Following the writing of a 1 to the ME bit, the CLR bit is also cleared to zero. If the clear enable bit is set, but a command other than writing a 1 to the clear memory bit is issued next, the CLR bit is cleared to a zero and the contents of the event log, start time stamp, and event counter register are unchanged.

DIS1, DIS0 - Duration Interval Select [0-1] – These bits select the amount of time between increments of the elapsed time counter that is used to determine the amount of time between events. After the first event is recorded, all subsequent events are recorded as the elapsed time since the previous event. When a subsequent event occurs, the ETC value is stored in the event log memory.

In order to obtain the maximum accuracy of the event logger, the smallest possible resolution of the ETC should be selected. The expected maximum time between events must also be taken into account in order to get the full 1025 events logged because when the ETC count reaches 65535 increments, if the next event has not occurred by that point in time, FFh will be written into the memory, the ETC will roll over to 00h and continue to count until the next event occurs or FFh is reached again. Whenever FFh is reached by the ETC, it will store that value in event log memory, reset to 00h, continue counting, and the memory address pointer will increment to the next memory location. When ever an FFh appears in the memory, the next two bytes of data will be part of the elapsed time for the same event, even if the value in the next two bytes of memory are 00h which means that an event occurred at time increment FFh. In order to recover the total elapsed time between events when a FFh is in the Event Log Memory; simply add the contents of the next two bytes to the FFh. If the next two bytes are 00h indicating that the event occurred at FFh, by adding the 00h in the next two bytes, you will end up with FFh. If the next two bytes are 01h, you will get 100h when the data is added to FFh. This will represent the total elapsed time since the previous event. The event counter will not be incremented when the ETC rolls over since a new event has not occurred.

The ETC will be incremented as the selected single seconds, minutes, or hours byte of the RTC increments to prevent time losses from short duration events. Since the time base in the RTC continues to run, even when the ETC is cleared to prepare for a new event, and the ETC is incremented every time the selected byte in the RTC increments, the actual time resolution will not be lost even when events occur more frequently than the minimum time resolution selected. If an event occurs half way between increments of the ETC, then the first increment of the next event will occur when the seconds, minutes or hours register increments next, thus preserving the correct time to the resolution selected in the DISx bits. The user can select one of the settings in Table 2.

When the Alarm Interrupt Output is to be used, the DISx bits should be set to zeros, which will disable the ETC and the rest of the event logger circuitry to conserve battery life. An event-logging mission can not be started if the DISx bits are both set to zero. This will enable the Alarm Flag to generate an Alarm Interrupt via the $\overline{\text{INT}}$ output pin.

With the DIS0 bit set to a one and the DIS1 bit set to zero, the ETC will increment every time the single seconds byte in the RTC is incremented. This will give the maximum resolution between events, but since the counter is limited to only 16 bit and will roll over to the next two memory bytes when it reaches the maximum value, the largest interval between events that can be accurately measured without using additional memory space and reducing the total number of events able to be logged is 65,535 seconds or about 18.2 hours. If the maximum time between events could be greater than 18.2 hours, you should consider using one of the courser resolutions to conserve memory.

With the DIS0 bit set to a zero and the DIS1 bit set to a one, the ETC will increment every time the single minutes byte in the RTC is incremented. This will give a medium resolution between events, but will increase the largest possible interval between events that can be accurately measured without using additional memory space and reducing the total number of events able to be logged to 65,535 minutes or about 45.5 days. If the maximum time between events could be greater than 45.5 days, you should consider using one of the courser resolutions to conserve memory.

With both of the DISx bits set to a one, the ETC will increment every time the single hours byte in the RTC is incremented. This will give the lowest resolution between events, but will increase the largest possible interval between events that can be accurately measured without using additional memory space and reducing the total number of events able to be logged to 65,535 hours or about 7.5 years.

In the event that a second event occurs before the ETC is able to increment for the first time, all zeros will be logged in the event log memory and the ETC will be reset. If this occurs, the time base will remain correct since it is based on the separate RTC incrementing, but the exact time of the event will be no more accurate than the size of the time increment that is chosen. For this reason, it is recommended to use the finest resolution possible for your logging to minimize the errors. If the normal duration between events is several days or months, then a few minutes or an hour may not be significant to your data accuracy.

As an example, an event occurs after 28h hours which causes the ETC to be reset. The ETC is set to increment on the hour, but the next event happens after 45 minutes. The value recorded in the event log memory is 00h, the event counter is incremented, and the ETC is cleared to begin counting for the next event. That next event happens 20 minutes later, but the value in the ETC is 01h because the RTC incremented the ETC on the hour, which was 15 minutes after the last event was recorded in the event log memory. We now know that in the course of about an hour three events took place. If this is normal, then we should have chosen a finer resolution, but this does sometimes happen, even when events are normally spread widely apart. We did not loose any data in our example because we know in which hour the events took place and when we chose the resolution, we decided that knowing which hour was accurate enough for our needs. The RTC maintained the correct time base, even though the ETC was cleared before it was incremented even once for the second event in our example. The third event incremented after only 15 minutes, but, relative to the first event in our example, this was correct because the second event occurred after 45 minutes, and the third event was incremented after an additional 15 minutes, which makes one hour.

DURATION INTERVAL SELECT BITS Table 2

DIS1	DIS0	ELAPSED TIME COUNT RESOLUTION	MAX. TIME BETWEEN EVENTS
0	0	Alarm Interrupt Output Enabled	
0	1	The Counter will Increment Every Second	18.2 Hours
1	0	The Counter will Increment Every Minute	45.5 Days
1	1	The Counter will Increment Every Hour	7.5 Years

RO - Roll-Over – This bit determines whether the datalog function of the DS1678 rolls over or stops writing data to the event log memory if the event log memory is completely filled. If RO is set to a 1, the event log memory will “roll over” after all 2048 bytes in the event log memory have been used. In other words, after the 1024th event recorded in the event log memory, the following sample will have the full time/date stamp information written to the start time stamp register and the contents of the ETC written to the 2-byte following the start time stamp (event 0 elapsed time from last event) and the next sample will have the duration of time from the new start time stamp value written to event log memory address

locations 0000h and 0001h, overwriting the original data. Likewise, subsequent samples will increment through the event log registers, overwriting their data.

The event 0 elapsed time from last event bytes will have the elapsed time since the last event in the event log memory. This is to allow the user to recover the information prior to the rollover. At the start of a mission, the value in these 2 bytes will be all zeros since there was no previous event from which to have an elapsed time.

If RO is set to a 0, no further event logs will be written to the event log memory after all event log memory registers have been filled. Events, however, will continue to be recognized and the Event Count register will be incremented for each event. Likewise, the RTC alarm flag will also continue to function.

TR1, TR0 - Trigger Select [1,0] – This bit selects the edge(s) that will activate the $\overline{\text{INT}}$ pin to cause an event to be logged. An event can be triggered one of three ways depending on the settings of the TRx bits in the control register. With TR0 bit set to a 1 and TR1 bit set to a 0, the $\overline{\text{INT}}$ signal will be activated on the falling edge of the input signal. With the TR0 bit set to a 0 and the TR1 bit set to a 1, the $\overline{\text{INT}}$ pin will be activated on the rising edge of the input signal.

With both TR0 and TR1 bits set to 1, the $\overline{\text{INT}}$ pin will be activated by both the rising and falling edges to allow for the measurement of on/off type events and their durations. If TR0 and TR1 are both set to 0, nothing will happen when the $\overline{\text{INT}}$ pin is toggled and a mission will not start. This is an illegal state and the mission will not start without a valid value in the TRx bits prior to attempting to start the mission.

TRIGGER SELECT BITS Table 3

TR1	TR0	EDGE(S) USED TO TRIGGER AN EVENT
0	0	Nothing, Illegal State
0	1	Falling Edge
1	0	Rising Edge
1	1	Both Rising and Falling Edges

COE - Clock Oscillator Enable – This bit allows the clock oscillator to be shut off to save power. The RTC will no longer keep time when the oscillator is shut off, but the information stored in the device memory will be maintained. An event log mission can not start with COE set to zero and the RTC must be reset to the correct value after the oscillator is restarted and prior to starting a mission in order to obtain good data. A clear memory can also not be executed without the oscillator running. When $V_{CC} > V_{BAT}$, the oscillator will automatically start, no matter what the value in the COE bit to allow proper communications. This is a way to preserve the data longer in battery mode once a mission has been completed in order to increase the battery life and thus the data integrity lifetime.

STATUS REGISTER

MSB						LSB	
0	MEM CLR	MIP	CM	LOBAT	ROF	0	ALMF

MEM CLR - Memory Cleared – This bit indicates that the event log memory, event count, and start time stamp registers are all cleared to zero. MEM CLR is cleared to zero when an event log mission is started (i.e., MIP = 1).

MIP - Mission in Progress – This bit indicates the sampling status of the DS1678. If MIP is logic 1, the device is currently on a “mission” in which it is operating in the event logging mode. The MIP bit is changed to logic 1 immediately following the activation of the $\overline{\text{INT}}$ pin if the ME bit of the control register contains a 1. In order to immediately start an event logging mission via the 2-wire bus, a 1 can be written into the MIP bit and a 1 will automatically be written into the ME bit of the control register.

If MIP is logic 0, the DS1678 is not currently in event logging mode. The MIP bit transitions from logic 1 to logic 0 whenever event logging is stopped. Event logging is stopped when the DS1678 is cleared by writing to the clear enable and memory clear bits or when any memory location including the RTC or control registers are written to during a mission. The MIP bit can also be written to logic 0 by the end user to stop event logging via the 2-wire bus. By writing a 0 to the MIP bit and stopping the mission, a 0 is automatically written to the ME bit of the control register. It cannot, however, be written to logic 1 to start a mission unless the MEM CLR bit is a 1 to signify that the memory has been cleared.

CM - Clear Memory – This bit will trigger the memory to be cleared if the CLR clear enable and COE clock oscillator enable bits in the control register are set to a 1. This will cause the event log memory, event count, and start time stamp registers to all be cleared to zeros. Once the memory has been cleared, the CLR enable bit and the CM bits will be set to zeros and the MEM CLR bit will be set to a 1 to allow a new mission to begin. Clearing the memory is a two-write process to reduce the risk of accidentally erasing the memory. The CLR bit must be set to a 1 before the CM bit can be written to a 1. During the clear memory operation the DS1678 should not be accessed for 500 μ s while the memory is erased. The MEM CLR bit should read a 1 before trying to access the cleared memory or registers.

LOBAT - Low Battery Flag – This bit reflects the status of the backup power source connected to the V_{BAT} pin. A logic 1 for this bit indicates an exhausted lithium energy source.

ROF - Roll Over Flag – This bit will be set to a one if the RO bit of the control register is set to a one, the last data log memory location has been filled and a new event has occurred, which will cause the time/date stamp to be over written. If RO is set to a 0 (roll over is disabled), the last data log memory location has been filled and an new event has occurred, ROF will be set to a 1 to indicate that more events have occurred than the number of available memory locations. The event counter will continue to record events, even after the event log memory is full. The ROF is cleared by the clear memory command.

ALMF - Alarm Flag – A logic 1 in the alarm flag bit indicates that the current time has matched the time-of-day alarm registers. If at the same time, the DISx bits are both logic 0’s, the $\overline{\text{INT}}$ pin will go low to issue an alarm interrupt. ALMF is a read only bit and is cleared by accessing any of the Alarm register bytes either with a read or a write. Writing any memory location during a mission will stop the mission. A mission can not be started when the DISx bits are both set to 0.

EVENT COUNTER

This 3-byte register set provides the number of events that have been logged during the current data logging operation (also known as a “mission”). The contents of this register can be used by software to point to the most recent data sample in the event log memory. The data in these registers are cleared when the event log memory is cleared. The event counter is not incremented when the ETC reaches FFh and rolls over to the next 16 bits of memory.

ADDRESS POINTER REGISTER

The address pointer register always contains the address that the next data LSB will be written to in the event log memory. The address pointer registers are located in the main memory map at LSB (3Fh) and

MSB (40h). These will be helpful in recovering all of the data if a rollover occurs. The address pointer will point to the oldest event in the memory after a rollover. This is the memory location that would be over written by the next event. Read the data from this point to the end of the memory and the start time stamp including the 2-byte ETC from last event in order to recover all of the data in the correct order.

GLITCH CONTROL CIRCUIT

The DS1678 has a built-in glitch control circuit to filter noise on the $\overline{\text{INT}}$ pin from triggering false events. A minimum of one internal clock cycle (0.122ms) up to a maximum of two internal clock cycles (0.245ms) are required to recognize a transition on the input as an event. An event then requires an additional six to eight internal clock cycles (0.752ms to 0.977ms) to be processed and recorded into memory. This means that the minimum event occurrence that can be recognized by the DS1678 requires seven to 10 internal clock cycles (0.854ms to 1.22ms). Failure to ensure this timing will cause the event to be ignored. Thus, it is recommended that you design with the maximum timing specs.

The $\overline{\text{INT}}$ pin has a weak internal pull-down resistor to prevent the pin from floating if the signal connected to the pin is tri-stated. Without the resistor, the input would float and potentially log phantom events. With the pull-down resistor, the pin can be transitioned to a low state causing an event to be recorded if the $\overline{\text{INT}}$ pin was being held high by an outside signal that becomes tri-stated.

SECURITY

The DS1678 provides several measures to insure data integrity for the end user. These security measures are intended to prevent third-party intermediaries from tampering with the data that has been stored in the event log memory.

As a first security measure, the event log memory is read-only from the perspective of the end user. The DS1678 can write the data into these memory banks, but the end user cannot write data to individual registers. This prevents an unscrupulous intermediary from writing false data to the DS1678. The end user, however, can clear the contents of the event log memory. A new mission can not be started unless the MEM CLR bit has been set to a 1 to indicate that the memory and registers are cleared.

As a second security measure, changing any value in the memory including the RTC and control registers will stop event logging and clear the MIP and ME bits. The MEM CLR bit must be set to 1 so that the memory and registers are cleared before a new event log mission can begin.

POWER CYCLING

When V_{CC} falls below $1.25 \times V_{BAT}$ the device automatically write protects itself, terminates any access in progress and resets the device address counter. Inputs to the device via the 2-wire bus will not be recognized at this time to prevent erroneous data from being written to the device from an out of tolerance system. When V_{CC} falls below V_{BAT} the device switches into a low-current battery backup mode. Upon power-up, the device switches from battery power to V_{CC} when V_{CC} is greater than $V_{BAT} + 0.2V$ and recognizes inputs from the system when V_{CC} is greater than $1.25 \times V_{BAT}$ by releasing control of the write protection on the 2-wire bus.

2-WIRE SERIAL DATA BUS

The DS1678 supports a bi-directional, 2-wire bus and data transmission protocol. A device that sends data onto the bus is defined as a transmitter, and a device receiving data as a receiver. The device that controls the message is called a “master.” The devices that are controlled by the master are “slaves.” The bus must be controlled by a master device that generates the serial clock (SCL), controls the bus access,

and generates the START and STOP conditions. The DS1678 operates as a slave on the 2-wire bus. Connections to the bus are made via the open-drain I/O lines SDA and SCL.

The following bus protocol has been defined (See Figure 3):

- Data transfer may be initiated only when the bus is not busy.
- During data transfer, the data line must remain stable whenever the clock line is HIGH. Changes in the data line while the clock line is high will be interpreted as control signals.

Accordingly, the following bus conditions have been defined:

Bus not busy: Both data and clock lines remain HIGH.

Start data transfer: A change in the state of the data line, from HIGH to LOW, while the clock is HIGH, defines a START condition.

Stop data transfer: A change in the state of the data line, from LOW to HIGH, while the clock line is HIGH, defines the STOP condition.

Data valid: The state of the data line represents valid data when, after a START condition, the data line is stable for the duration of the HIGH period of the clock signal. The data on the line must be changed during the LOW period of the clock signal. There is one clock pulse per bit of data.

Each data transfer is initiated with a START condition and terminated with a STOP condition. The number of data bytes transferred between START and STOP conditions is not limited, and is determined by the master device. The information is transferred byte-wise and each receiver acknowledges with a ninth bit. Within the bus specifications a regular mode (100kHz clock rate) and a fast mode (400kHz clock rate) are defined. The DS1678 works in both modes.

Acknowledge: Each receiving device, when addressed, is obliged to generate an acknowledge after the reception of each byte. The master device must generate an extra clock pulse which is associated with this acknowledge bit.

A device that acknowledges must pull down the SDA line during the acknowledge clock pulse in such a way that the SDA line is stable LOW during the HIGH period of the acknowledge related clock pulse. Of course, setup and hold times must be taken into account. A master must signal an end of data to the slave by not generating an acknowledge bit on the last byte that has been clocked out of the slave. In this case, the slave must leave the data line HIGH to enable the master to generate the STOP condition.

Figure 4 details how data transfer is accomplished on the 2-wire bus. Depending upon the state of the R/\overline{W} bit, two types of data transfer are possible:

1. **Data transfer from a master transmitter to a slave receiver.** The first byte transmitted by the master is the slave address. Next follows a number of data bytes. The slave returns an acknowledge bit after each received byte.
2. **Data transfer from a slave transmitter to a master receiver.** The first byte (the slave address) is transmitted by the master. The slave then returns an acknowledge bit. Next follows a number of data bytes transmitted by the slave to the master. The master returns an acknowledge bit after all received bytes other than the last byte. At the end of the last received byte, a “not acknowledge” is returned.

The master device generates all of the serial clock pulses and the START and STOP conditions. A transfer is ended with a STOP condition or with a repeated START condition. Since a repeated START condition is also the beginning of the next serial transfer, the bus will not be released.

The DS1678 may operate in the following two modes:

1. **Slave receiver mode (DS1678 write mode):** Serial data and clock are received through SDA and SCL. After each byte is received, the receiver transmits an acknowledge bit. START and STOP conditions are recognized as the beginning and end of a serial transfer. The slave address byte is the first byte received after the start condition is generated by the master. The address byte contains the 7-bit DS1678 address, which is 1001010, followed by the direction bit (R/\overline{W}), which is 0. The second byte from the master is the register address. This sets the register pointer. If the write is being done to set the register pointer, a STOP or repeated START may then be sent by the master. Otherwise, the master then transmits each byte of data, with the DS1678 acknowledging each byte received. The master will generate a stop condition to terminate the data write (See Figure 4).
2. **Slave transmitter mode (DS1678 read mode):** The first byte is received and handled as in the slave receiver mode. However, in this mode, the direction bit will indicate that the transfer direction is reversed. Serial data is transmitted on SDA by the DS1678 while the serial clock is input on SCL. The slave address byte is the first byte received after the start condition is generated by the master. The address byte contains the 7-bit DS1678 address, which is 1001010, followed by the direction bit (R/\overline{W}), which is 1. After receiving a valid slave address byte and direction bit, the DS1678 generates an acknowledge on the SDA line. The DS1678 begins to transmit data on each SCL pulse starting with the register address pointed to by the register pointer. As the master reads each byte, it must generate an acknowledge. The DS1678 must receive a “not acknowledge” on the last byte to end a read (See Figure 4).

ABSOLUTE MAXIMUM RATINGS*

Voltage on Any Pin Relative to Ground	-0.3V to +6V
Operating Temperature	-40°C to +85°C
Storage Temperature	-55°C to +125°C
Soldering Temperature	See J-STD-020A specification

* This is a stress rating only and functional operation of the device at these or any other conditions above those indicated in the operation sections of this specification is not implied. Exposure to absolute maximum rating conditions for extended periods of time may affect reliability.

RECOMMENDED DC OPERATING CONDITIONS (-40°C to +85°C)

PARAMETER	SYMBOL	MIN	TYP	MAX	UNITS	NOTES
Power Supply Voltage	V_{CC}	4.5	5.0	5.5	V	
Input Logic 1	V_{IH}	2.2		$V_{CC} + 0.3$	V	
Input Logic 0	V_{IL}	-0.3		+0.8	V	
Battery Voltage	V_{BAT}	2.6		3.5	V	

DC ELECTRICAL CHARACTERISTICS (-40°C to +85°C)

PARAMETER	SYMBOL	MIN	TYP	MAX	UNITS	NOTES
Input Leakage	I_{LI}	-1		+1	μ A	
Logic 0 Output $I_{OL} = 4\text{mA}$	V_{OL}			0.4	V	
Output Current 0.4V						
Active Supply Current	I_{CCA}		1	2	mA	
Battery Standby Current (Oscillator On)	I_{OSC}		300	500	nA	
Battery Standby Current (Oscillator Off)	I_{BAT}		50	150	nA	
Power-Fail Voltage	V_{PF}	$1.216 \times V_{BAT}$	$1.25 \times V_{BAT}$	$1.284 \times V_{BAT}$	V	6

AC ELECTRICAL CHARACTERISTICS (-40°C to 85°C, $V_{CC} = 2.6\text{V}$ to 5.5V)

PARAMETER	SYMBOL	MIN	TYP	MAX	UNITS	NOTES
Input Capacitance	C_I		10		pF	
Crystal Capacitance	C_X		12.5		pF	
Minimum Signal Width	t_{GLITCH}	0.122		0.245	ms	
Minimum Event Rate	t_{EVENT}	0.854		1.22	ms	

AC ELECTRICAL CHARACTERISTICS (-40°C to +85°C, $V_{CC} = 4.5V$ to 5.5V)

PARAMETER	SYMBOL	CONDITION	MIN	TYP	MAX	UNITS	NOTES
SCL Clock Frequency	f_{scl}	Fast Mode Standard Mode	100		400 100	kHz	
Bus Free Time Between a STOP and START Condition	t_{buf}	Fast Mode Standard Mode	1.3 4.7			μs	
Hold Time (Repeated) START Condition.	$t_{hd:sta}$	Fast Mode Standard Mode	0.6 4.0			μs	1
LOW Period of SCL	t_{low}	Fast Mode Standard Mode	1.3 4.7			μs	
HIGH Period of SCL	t_{high}	Fast Mode Standard Mode	0.6 4.0			μs	
Set-Up Time for a Repeated START	$t_{su:sta}$	Fast Mode Standard Mode	0.6 4.7			μs	
Data Hold Time	$t_{hd:dat}$	Fast Mode Standard Mode	0 0		0.9	μs	2
Data Set-up Time	$t_{su:dat}$	Fast Mode Standard Mode	100 250			ns	3
Rise Time of Both SDA and SCL Signals	t_r	Fast Mode Standard Mode	20 + $0.1C_b$		300 1000	ns	4
Fall Time of Both SDA and SCL Signals	t_f	Fast Mode Standard Mode	20 + $0.1C_b$		300 300	ns	4
Set-up Time for STOP	$t_{su:sto}$	Fast Mode Standard Mode	0.6 4.0			μs	
Capacitive Load for Each Bus Line	C_b				400	pF	4
Input Capacitance	C_i			5		pF	

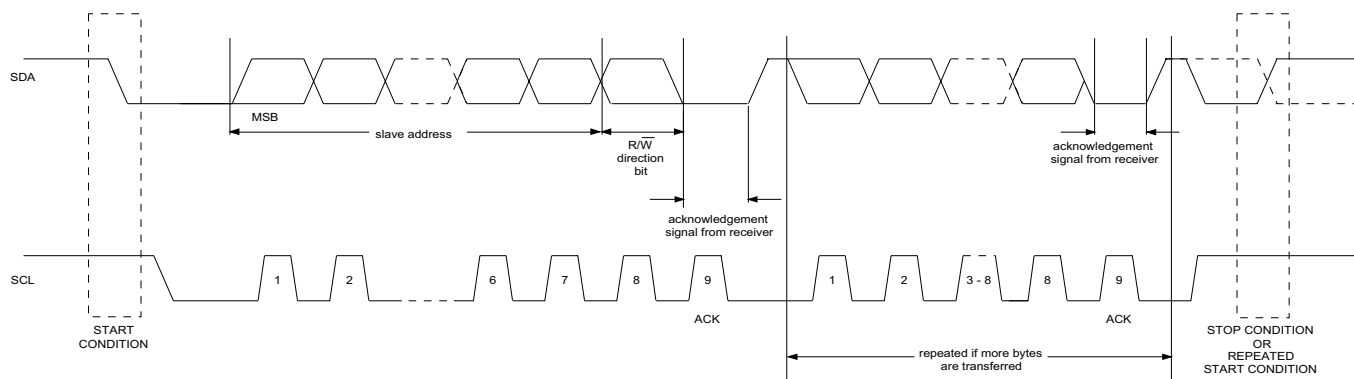
DATA TRANSFER ON 2-WIRE SERIAL BUS Figure 3

2-WIRE SERIAL COMMUNICATION WITH DS1678 Figure 4

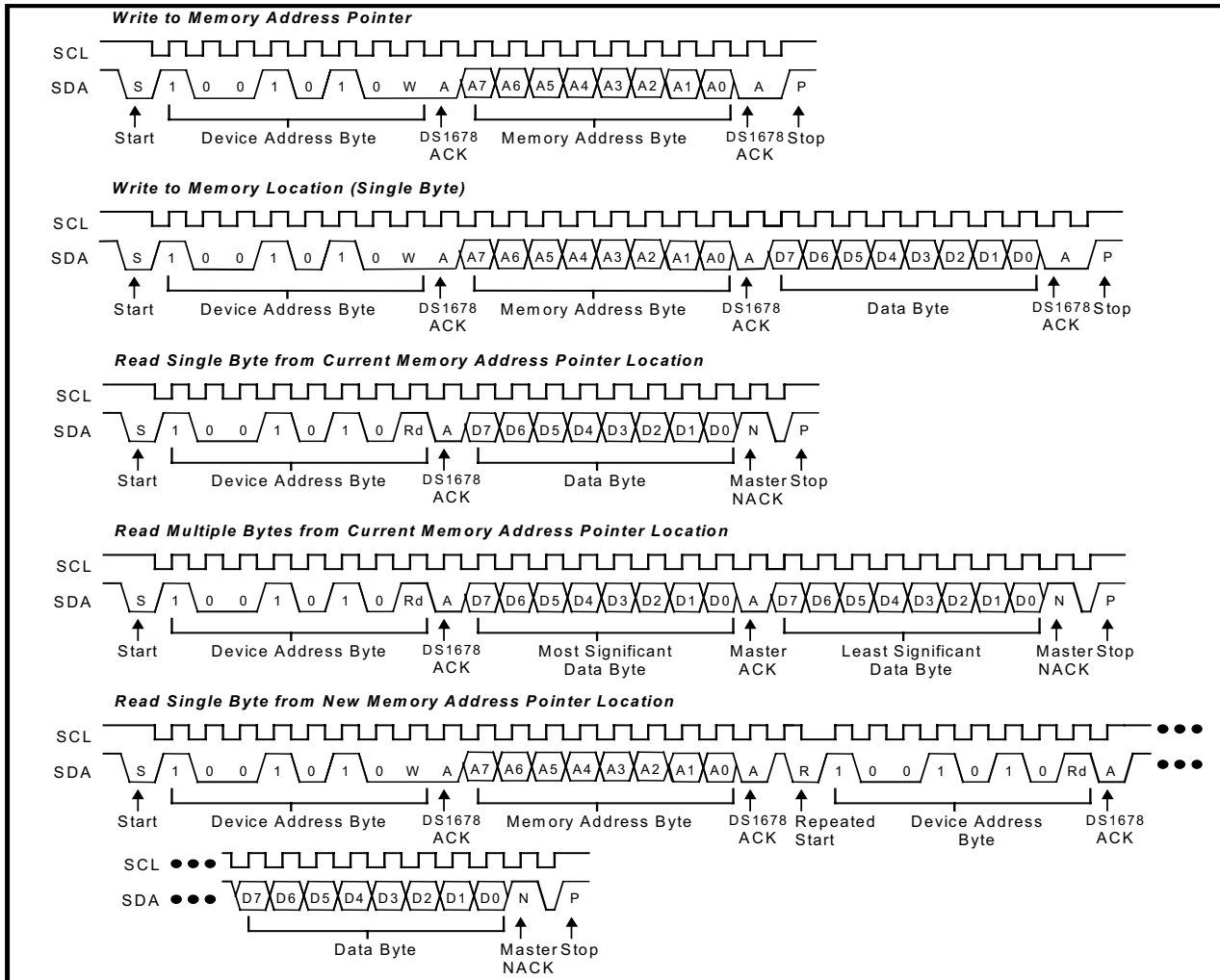

2-WIRE COMMUNICATION TIMING DIAGRAM Figure 5

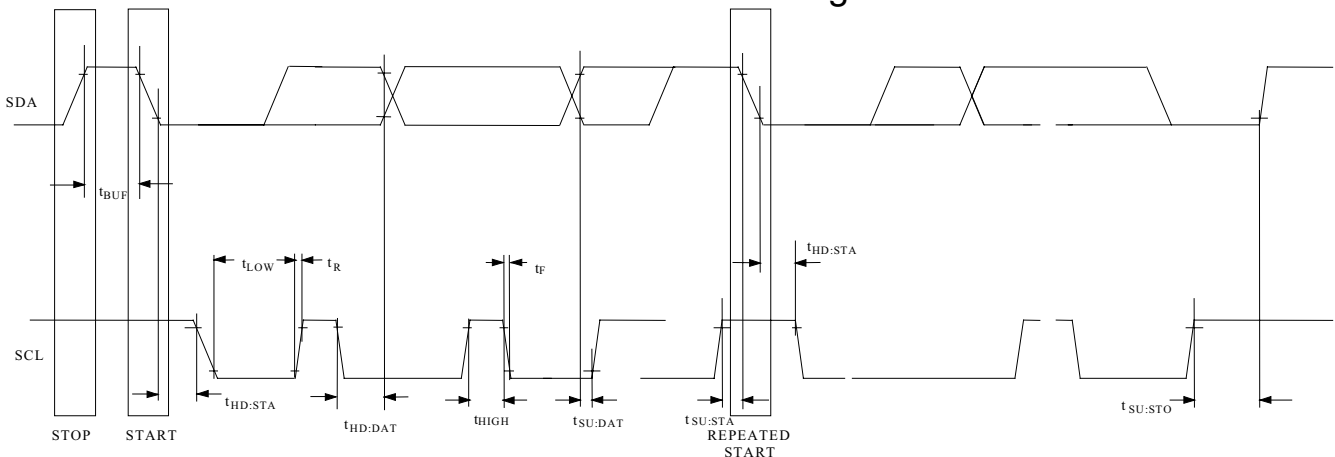

EVENT RECOGNITION TIMING DIAGRAM Figure 6a

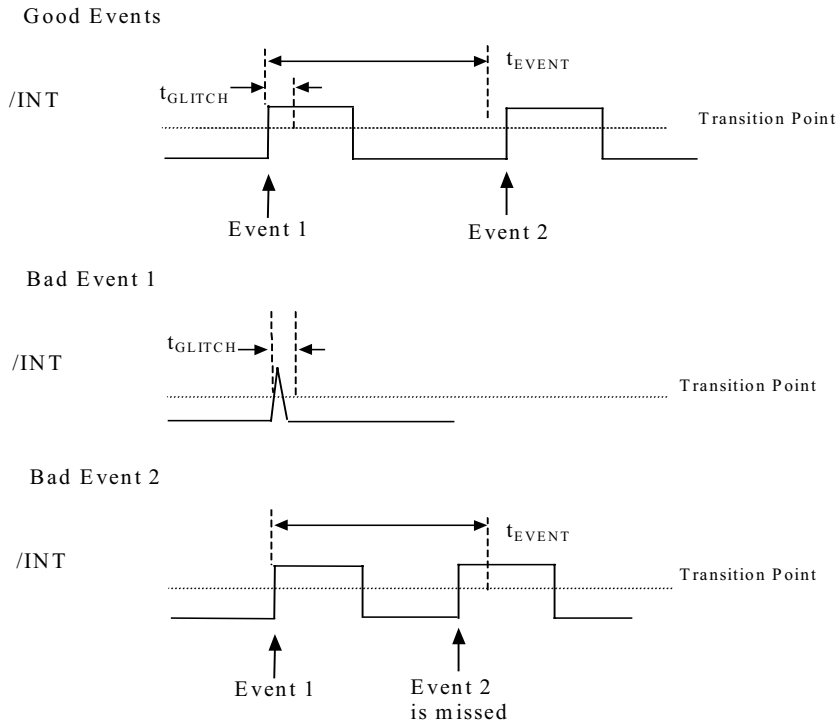

EVENT RECOGNITION TIMING DIAGRAM Figure 6b

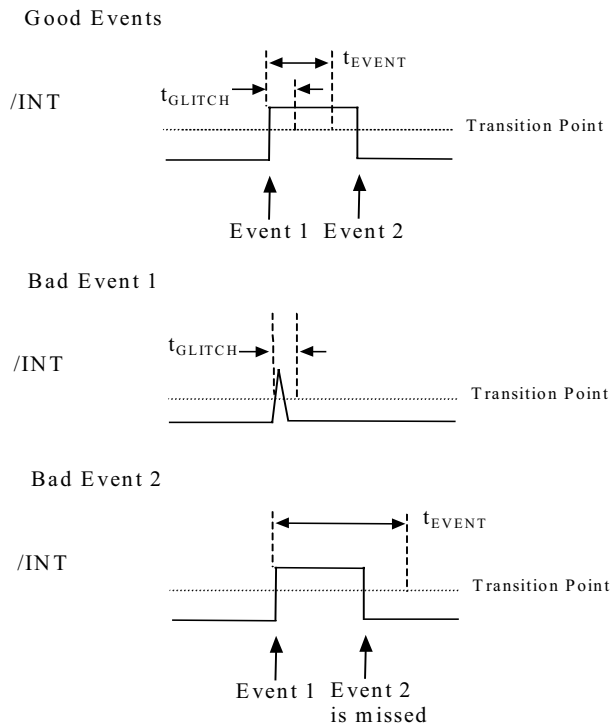

START MISSION FLOW CHART Figure 7

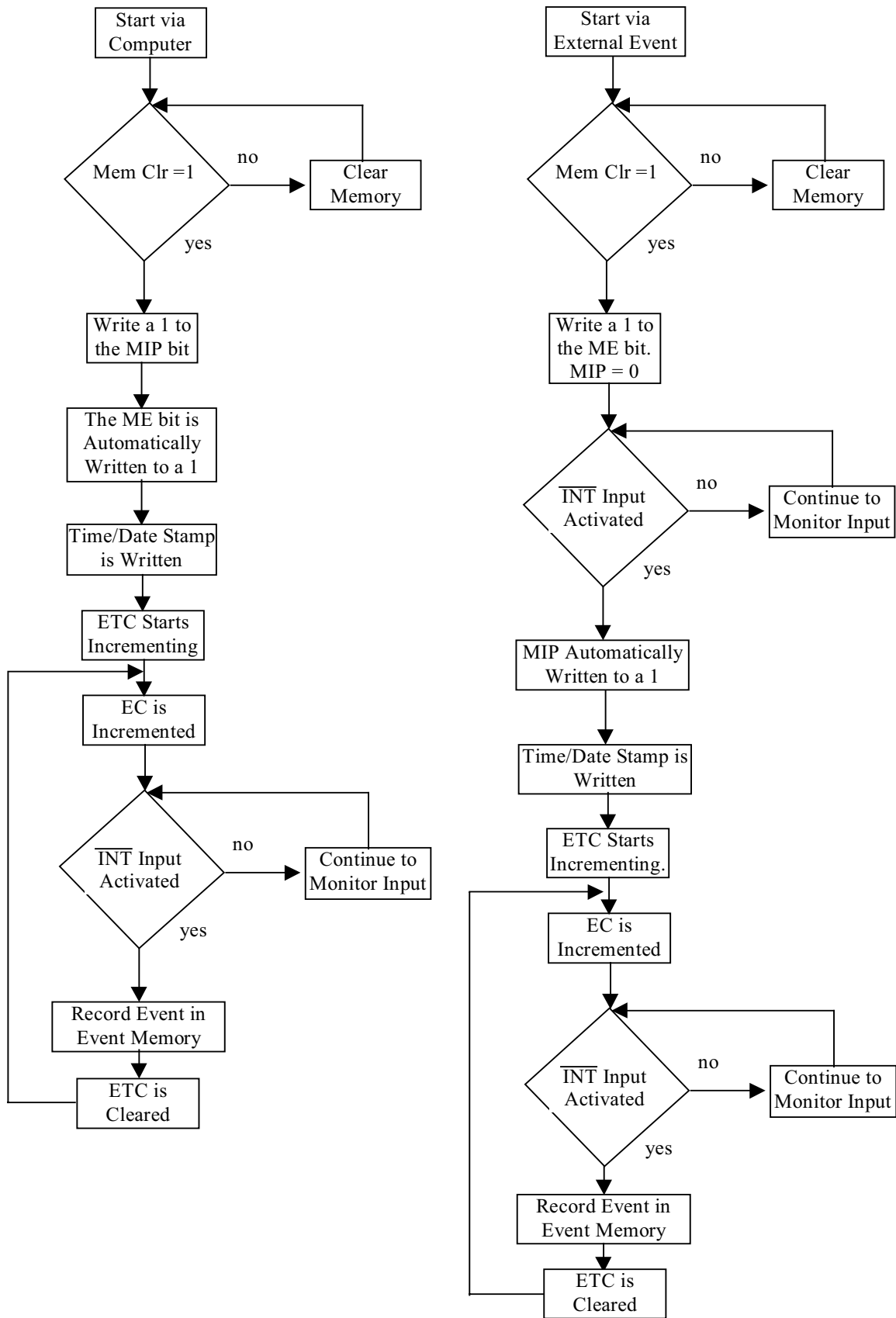

ROLL OVER FLOW CHART Figure 8

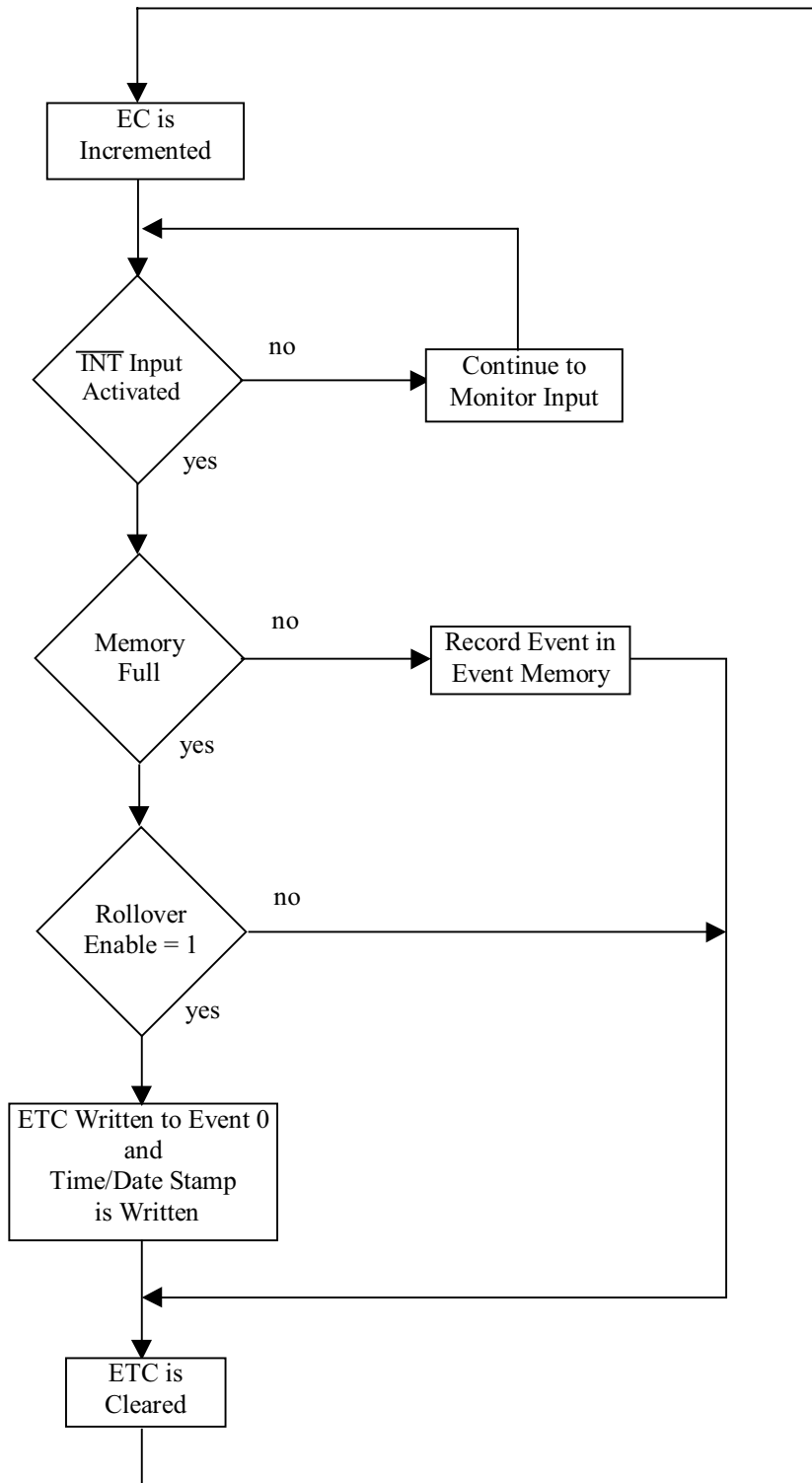

NOTES:

1. After this period, the first clock pulse is generated.
2. A device must initially provide a hold time of at least 300ns for the SDA signal in order to bridge the undefined region of the falling edge of SCL. The maximum $t_{hd:dat}$ has only to be met if the device does not stretch the LOW period (t_{low}) of the SCL signal.
3. A fast mode device can be used in a standard mode system, but the requirement $t_{su:dat} > 250ns$ must then be met. This will automatically be the case if the device does not stretch the LOW period of the SCL signal. If such a device does stretch the LOW period of the SCL signal, it must output the next data bit to the SDA line $t_{rMAX} + t_{su:dat} = 1000 + 250 = 1250ns$ before the SCL line is released.
4. C_B – Total capacitance of one bus line in pF.
5. t_R and t_F are measured with a 1.7k Ω pull-up resistor, 200pF pull-up capacitor, 1.7k Ω pull-down resistor and 5pF pull-down capacitor.
6. V_{pf} measures at $V_{BAT} = 3.0V$.