

GPS Engine Board

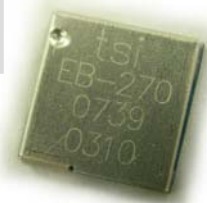

EB-270/ EB-271

EB-27x is an ultra miniature 10.4 x10.5 mm² GPS engine board. It provides superior navigation performance under dynamic conditions in areas with limited sky view like urban canyons. High sensitivity up to **-158dBm** for weak signal operation without compromising accuracy. EB-27x series is your best choice for embedded applications.



Key Features :

- Small form factor: 10.4 x 10.5 x 2.0 mm
- Lead-Free – RoHS/WEEE compliant
- High sensitivity -158dBm
- Tracks 51-Channel of satellites
- Fast Position Fix
- Low power consumption
- Backup Battery :
EB-270 DC 1.0~1.5V
EB-271 DC 1.5~6.0V

Applications :

- Handheld devices
- Automotive and Marine Navigation
- Automotive Navigator Tracking
- Emergency Locator
- Geographic Surveying
- Personal Positioning
- Sporting and Recreation
- Embedded applications : PDA, DSC, Smart phone, UMPC, PND, MP4

PIN Definition :

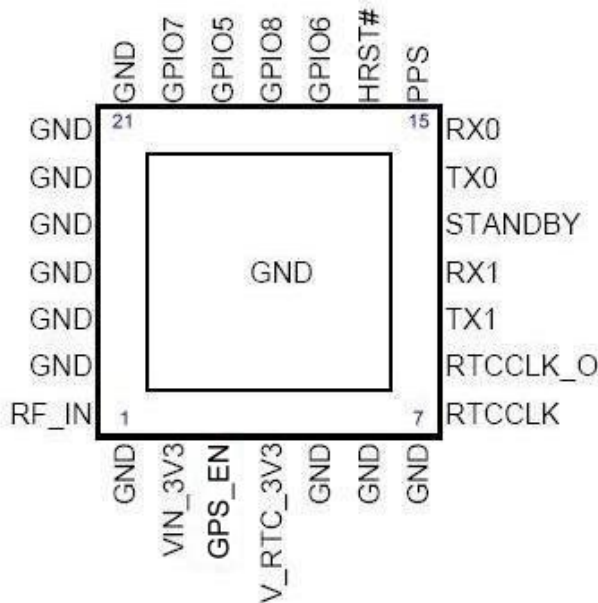

PIN Coordinates Unit:mm

Pin #	X	Y	Pin #	X	Y
1	0.00	0.00	15	6.60	10.40
2	1.10	0.00	16	5.50	10.40
3	2.20	0.00	17	4.40	10.40
4	3.30	0.00	18	3.30	10.40
5	4.40	0.00	19	2.20	10.40
6	5.50	0.00	20	1.10	10.40
7	6.60	0.00	21	0.00	10.40
8	8.55	1.90	22	-1.95	8.50
9	8.55	3.00	23	-1.95	7.40
10	8.55	4.10	24	-1.95	6.30
11	8.55	5.20	25	-1.95	5.20
12	8.55	6.30	26	-1.95	4.10
13	8.55	7.40	27	-1.95	3.00
14	8.55	8.50	28	-1.95	1.90



TRANSYSTEM INC.

An A+ supplier of RF microwave & GPS products

Ultimate

EB

EB-27x Specifications

Specification	Description
General	L1 frequency, C/A code (SPS) 51 independent tracking channels
Sensitivity	-158dBm /Tracking; -146dBm /Acquisition
Update Rate	Up to 5Hz
Accuracy	Without aid: 3.0m 2D-RMS <3m CEP (50%) without SA (horizontal) DGPS (WAAS, EGNOS, MSAS, RTCM): 2.5m
Acquisition (open sky)	Cold Start: 36sec Warm Start: 33sec Hot Start: 1sec
Reacquisition	< 1sec
Dynamics	Altitude: 18000m (max.) Velocity: 515m/sec (max.) Vibration: 4G (max.)
Supply Voltage	DC 3.0~6 V
Power Consumption	< 27.5mA @ 2.85V (w/o Active ANT) / Tracking
Backup Battery	EB-270: DC 1.0~1.5V EB-271: DC 1.5~6.0V
NMEA Message	NMEA0183 v3.1 baud rate 4800/9600/.../115200, default 115200 Selectable Output: GGA, GLL, GSA, GSV, RMC, and VTG
Datum	Default WGS-84
Antenna	External Active Antenna Output Voltage: 2.85 VDC
Serial Interface	UART
Operating Temperature	-30°C to 85°C
Storage Temperature	-40°C to 85°C
Operating Humidity	≤ 95%, non condensing
Mounting	SMT Type, 28 Pin
Dimension	10.4 x 10.5 x 2.0(H) mm

*Specifications subject to change without prior notice.

© 2007 TRANSYSTEM INC. all rights reserved.



Table of Contents

1	Introduction.....	4
1.1	Key Features	4
1.2	Applications	4
1.3	Look & Feel	4
2	Technical Description	5
2.1	Block Diagram	5
2.2	Pin Definition.....	6
2.3	Specification.....	7
3	Dimension and Package	8
3.1	Mechanical Dimension	8
3.2	Recommend Layout Pattern.....	8
3.3	Package	8
4	Application Information.....	9
4.1	GPS Antenna Recommendations	9
4.2	Application Circuit.....	10
4.3	General GPS Receiver User's Tips	11
4.4	How to avoid ESD damage to ICs	12

PRELIMINARY

1 Introduction

EB-27x is an ultra miniature 10.4 x10.5mm² GPS engine board. It provides superior navigation performance under dynamic conditions in areas with limited sky view like urban canyons. High sensitivity up to -158dBm for weak signal operation without compromising accuracy. EB-27x is your best choice for embedded applications.

1.1 Key Features

- Small form factor: 10.4 x 10.5 x 2.0 mm
- Lead-Free – RoHS/WEEE compliant
- High sensitivity -158dBm
- Tracks 51-Channel of satellites
- Fast Position Fix, 36/ 33/ 1s for Cold/ Warm/ Hot start
- Low power consumption

1.2 Applications

- Handheld devices
- Automotive and Marine Navigation
- Automotive Navigator Tracking
- Emergency Locator
- Geographic Surveying
- Personal Positioning
- Sporting and Recreation
- Embedded applications such as: PDA, DSC, Smart phone, UMPC, PND, MP4

1.3 Look & Feel

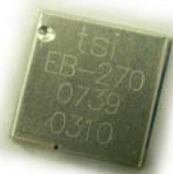

2 Technical Description

2.1 Block Diagram

EB-270 Block Diagram

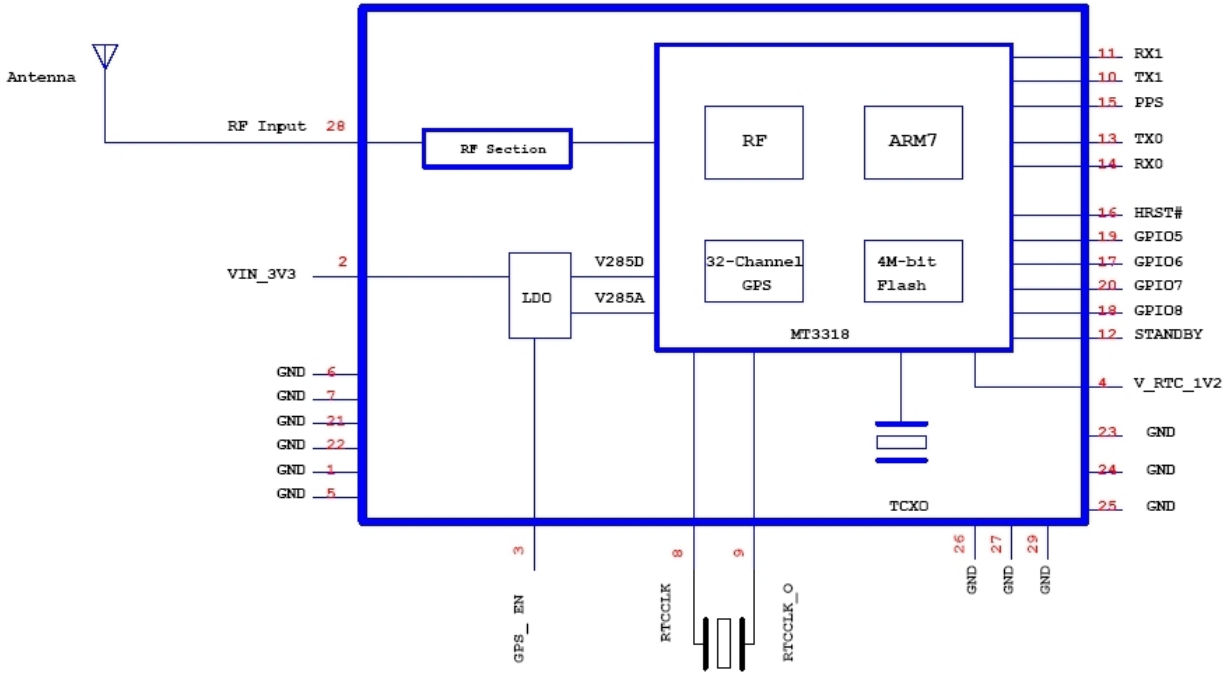

EB-271 Block Diagram

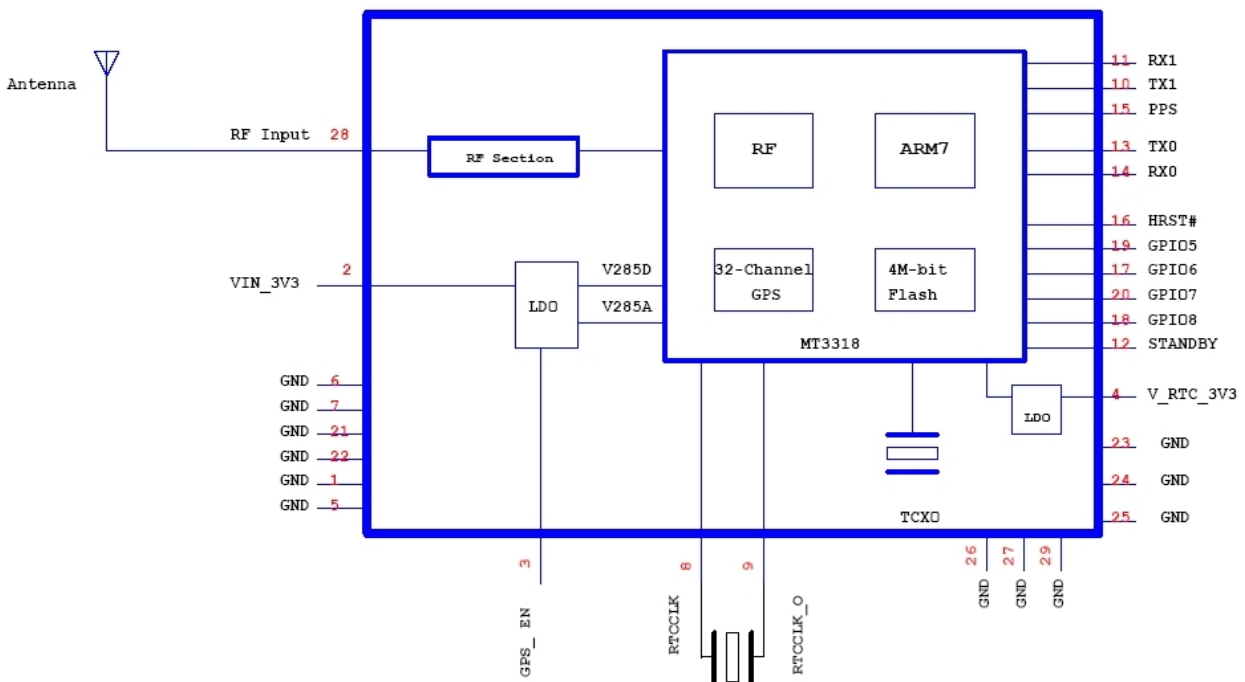

【Note】 : EB-271 is with V_RTC LDO, EB-270 is not

2.2 Pin Definition

Pin#	Signal Name	Type	Description
1	GND	P	Ground
2	VIN_3V3	P	Power Supply 3.0~6V DC
3	GPS_EN	I	Low to disable module; High to enable module
4	V_RTC_1V2; V_RTC_3V3	P	RTC power 1.0~1.5V DC; RTC power 1.5~6.0V DC (EB-271 with on-module LDO to 1.2V)
5	GND	P	Ground
6	GND	P	Ground
7	GND	P	Ground
8	RTCCLK	I	(Analog/ Input) RTC Xtal connection
9	RTCCLK_O	O	(Analog/ Output) RTC Xtal connection
10	TX1	O	GPS TX1
11	RX1	I	GPS RX1
12	STANDBY	I	STANDBY/ Interrupt, active low STANDBY is a function not ready for prime time
13	TX0	O	GPS TX0
14	RX0	I	GPS RX0
15	PPS	O	PPS
16	HRST#	I	GPS reset, active low. Internal pull high
17	GPIO6	I/O*	GIO or SO
18	GPIO8	I/O*	GIO or SCK
19	GPIO5	I/O*	GIO or SCS0#
20	GPIO7	I/O*	GIO or SIN
21	GND	P	Ground
22	GND	P	Ground
23	GND	P	Ground
24	GND	P	Ground
25	GND	P	Ground
26	GND	P	Ground
27	GND	P	Ground
28	RF_IN	I	(Analog) 50-ohm RF signal in, with DC bias to off-module

P: Power I: Input O: Output I/O*: Input or Output, Open if not used

2.3 Specification

EB-27x Specifications

<i>Specification</i>	<i>Description</i>
General	L1 frequency, C/A code (SPS) 51 independent tracking channels
Sensitivity	-158dBm /Tracking; -146dBm /Acquisition
Update Rate	Up to 5Hz
Accuracy	Without aid: 3.0m 2D-RMS <3m CEP (50%) without SA (horizontal) DGPS (WAAS, EGNOS, MSAS, RTCM): 2.5m
Acquisition (open sky)	Cold Start: 36sec Warm Start: 33sec Hot Start: 1sec
Reacquisition	< 1sec
Dynamics	Altitude: 18000m (max.) Velocity: 515m/sec (max.) Vibration: 4G (max.)
Supply Voltage	DC 3.0~6 V
Power Consumption	< 27.5mA @ 2.85V (w/o Active ANT) / Tracking
Backup Battery	EB-270: DC 1.0~1.5V EB-271: DC 1.5~6.0V
NMEA Message	NMEA0183 v3.1 baud rate 4800/9600/.../115200, default 115200 Selectable Output: GGA, GLL, GSA, GSV, RMC, and VTG
Datum	Default WGS-84
Antenna	External Active Antenna Output Voltage: 2.85 VDC
Serial Interface	TTL
Operating Temperature	-30°C to 85°C
Storage Temperature	-40°C to 85°C
Operating Humidity	≤ 95%, non condensing
Mounting	SMT Type, 28 Pin
Dimension	10.4 x 10.5 x 2.0(H) mm

3 Dimension and Package

3.1 Mechanical Dimension

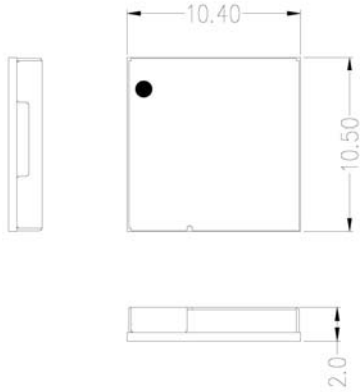

3.2 Recommend Layout Pattern

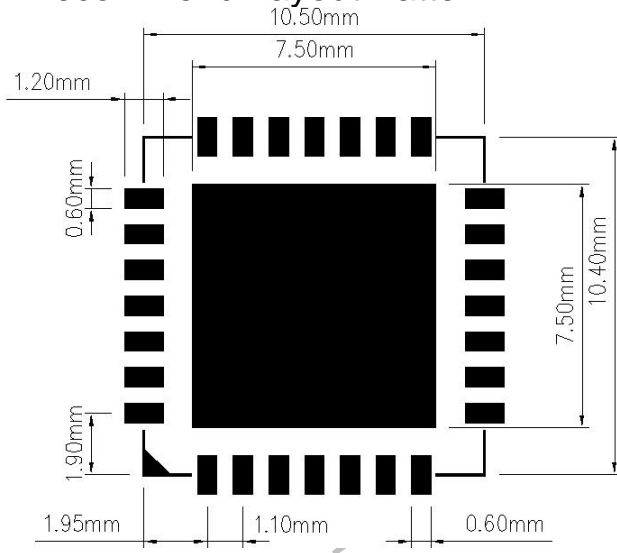

3.3 Package

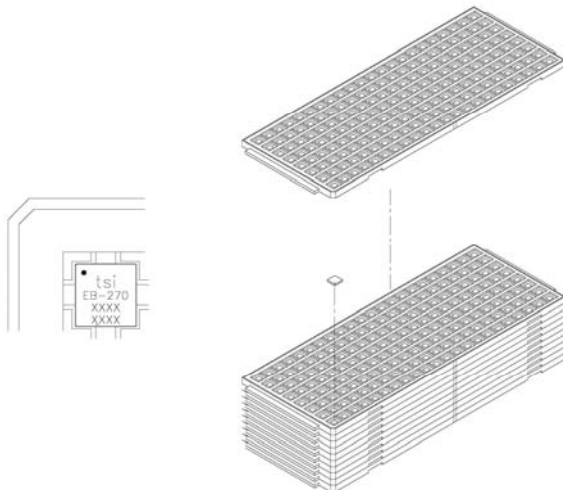

4 Application Information

4.1 GPS Antenna Recommendations

Follow below recommendations when choosing GPS antenna for EB-27x for best system performance. Transystem also offers active antenna products for optimal performance with EB-27x. For details, please contact your Transystem sales contact directly.

- Use active antenna that works with 3V power supply
- Receiving frequency $1575.42 \pm 1.032\text{MHz}$
- Polarization RHCP (right hand circular polarized)
- Output impedance = 50 Ohm
- $15\text{dB} \leq \text{LNA Gain} \leq 20\text{dB}$
- Noise figure $\leq 2.0\text{dB}$
- Connector: surface mounted on main PCB, Ipex or MMCX

4.2 Application Circuit

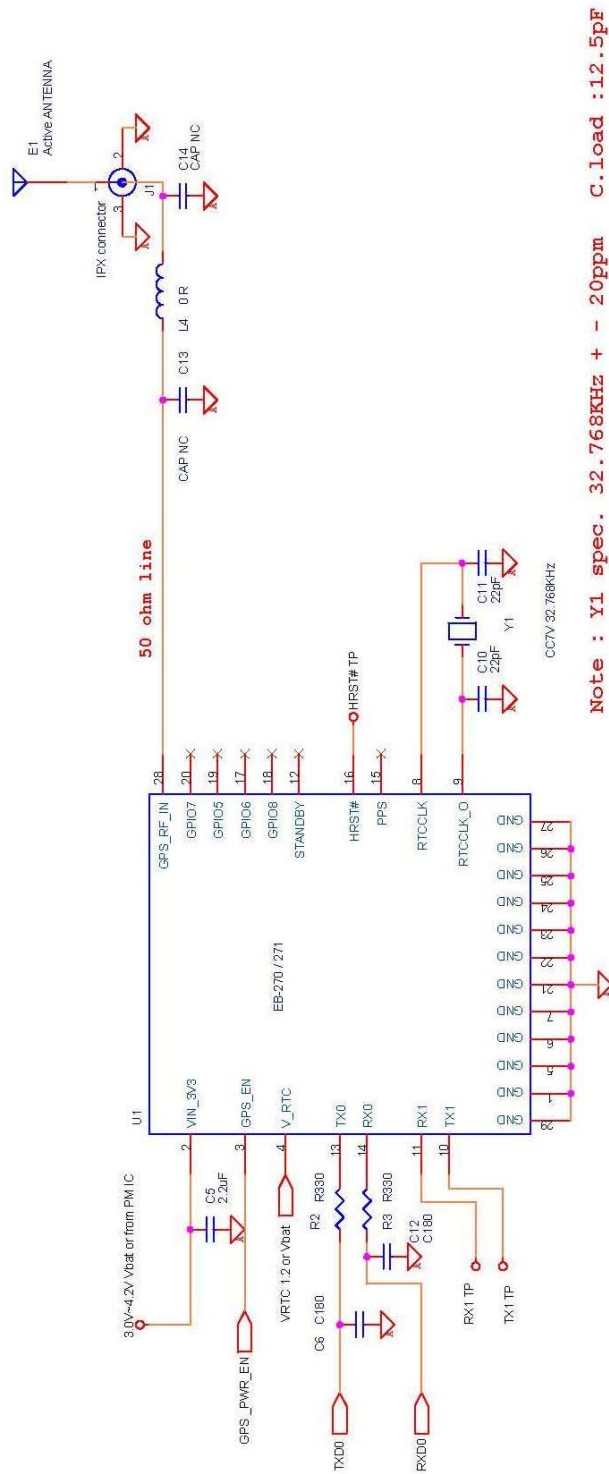

Note : Y1 spec. 32.768KHz + - 20ppm C.load :12.5pF

【Note 1】 Y1 spec. 32.768KHz + - 20ppm C.load :12.5pF

【Note 2】 : V_RTC_1V2 (pin#4) could connect to 1.2V DC power supply or battery directly. (EB-270)

【Note 3】 : V_RTC_3V3 (pin#4) could connect to 3.3V DC power supply or battery directly. (EB-271)

4.3 General GPS Receiver User's Tips

- If the satellite signals can not be locked or experiencing receiving problem (while in urban area), following steps are suggested:
 - a) Please plug the external active antenna into GPS receiver and put the antenna outdoor or on the roof of the vehicle for better receiving performance.
 - b) Move to another open space or reposition GPS receiver toward the direction with least blockage.
 - c) Move the GPS receiver away from the interference sources.
 - d) Wait until the weather condition is improved.
- Some vehicles having heavy metallic sun protecting coating on windshields may affect signal receptions
- Driving in and around high buildings may affect signal reception.
- Driving under tunnels or in buildings may affect signal reception.
- In general, GPS receiver performs best in open space where it can see clean sky. Weather will affect GPS reception – rain & snow contribute to worsen sensitivity.
- When GPS receiver is moving, it will take longer time to get position fix. Wait for satellite signals to be locked at a fixed point when first power-on the GPS receiver to ensure quick GPS position fix.

PRELIMINARY

4.4 How to avoid ESD damage to module

- Any person handling the module should be grounded either with a wrist strap or ESD-protective footwear used in conjunction with a conductive or static-dissipative floor or floor mat.
- The work surface where devices are placed for handling, processing, testing, etc., must, be made of static-dissipative material and be grounded to ESD ground.
- All insulator materials must either be removed from the work area or must be neutralized with an ionizer. Static-generating clothing must be covered with an ESD-protective smock.
- When module are being stored, transferred between operations or workstations, or shipped, they must be kept in a Faraday shield container with inside surfaces (surfaces touching the module) that are static-dissipative.

PRELIMINARY

Contact Information

Transystem Inc.
No. 1-2 Li-Hsin Rd. I,
Science-Based Industrial Park,
Hsinchu, Taiwan, R.O.C.
T : +886.3.578.0393
F : +886.3.578.4111
www.transystem.com.tw
sales@transystem.com.tw

PRELIMINARY