1. About this document

This document concerns the E-blocks MIDI board code EB021 version 1.

The order code for this product is EB021.

1. **Trademarks and copyright**

PIC and PICmicro are registered trademarks of Arizona Microchip Inc.

E-blocks is a trademark of Matrix Multimedia Limited.

2. **Other sources of information**

There are various other documents and sources that you may find useful:

Getting started with E-Blocks.pdf

This describes the E-blocks system and how it can be used to develop complete systems for learning electronics and for PICmicro programming.

PPP Help file

This describes the PPP software and its functionality. PPP software is used for transferring hex code to a PICmicro microcontroller.

C and assembly strategies

This is available as a free download from our web site.

3. **Disclaimer**

The information in this document is correct at the time of going to press. Matrix Multimedia reserves the right to change specifications from time to time. This product is for development purposes only and should not be used for any life-critical application.

4. **Technical support**

If you have any problems operating this product then please refer to the troubleshooting section of this document first. You will find the latest software updates, FAQs and other information on our web site:

www.matrixmultimedia.com . If you still have problems please email us at: support@matrixmultimedia.co.uk.

2. General information

1. Description

This E-block allows investigation of MIDI message and control protocols. MIDI stands for Musical Instrument Digital Interface and comprises of a standard communication protocol that enables electronic instruments such as synthesizers, samplers, sequencers, and drum machines from any manufacturer to communicate not only with one another, but also with computers. The Midi board can transmit, receive and pass on MIDI data via the three five pin DIN connectors. These connectors are labeled IN, OUT and THRU.

A set of jumper links are available which allow the MIDI E-block to easily be set for all PICmicro® microcontroller compatible devices. With the patch system available on board makes this board compatible with numerous other devices.

2. Features

- MIDI Input
- MIDI Output
- MIDI Through
- Optical isolation to prevent ground loops

3. Block schematic

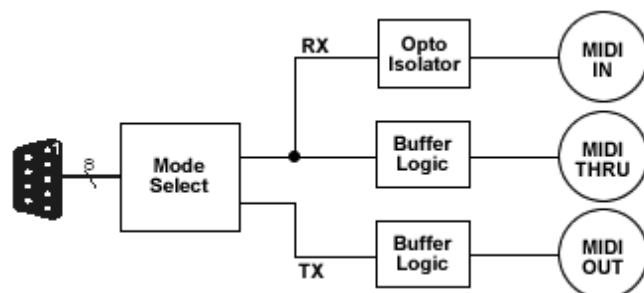

4. Programming Guide

MIDI devices transmit and receive commands via a serial method of communication. Each command is eight bits long with a start and a stop bit. The start bit is a logic 0 and the stop bit is a logic 1. Each bit should remain on the serial line for 32 microseconds meaning that a byte of data including start and stop bits takes 320 microseconds to send or receive. MIDI messages generally comprise of a command byte followed by up to 2 data bytes. There is a complication with the MIDI protocol involving real time messages. These real time messages can occur at any time any may be received between a command byte and its data byte so this has to be taken into account.

Example MIDI serial byte

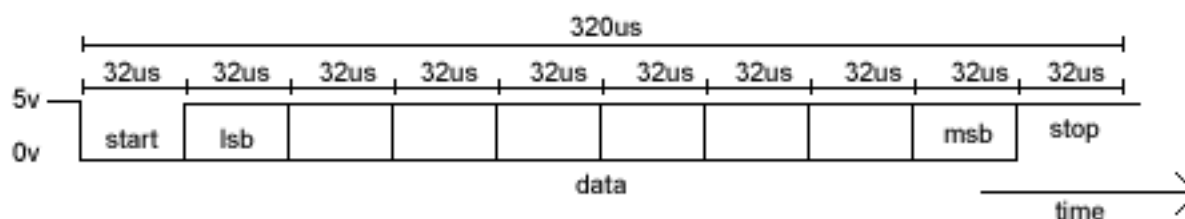

3. Board layout

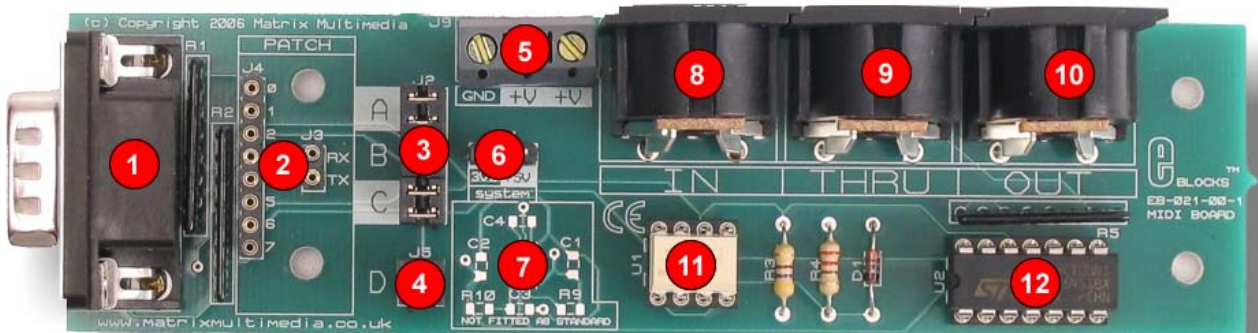

EB021-74-2.jpg

- 1) 9-way downstream D-type connector
- 2) Patch system
- 3) Receive and Transmit selection jumper pins
- 4) Patch Receive and Transmit selection jumper pins
- 5) Power screw terminals
- 6) MIDI VCC power selection Jumper
- 7) 3.3 Volt compatible circuit (not fitted as standard)
- 8) MIDI Input port
- 9) MIDI Through port
- 10) MIDI Output port
- 11) Optical Isolator chip
- 12) Quad NAND logic chip

General Guide for RX and TX settings:

	Jumper at A	Jumper at B	Jumper at C	Jumper at D
TX	Pin 5	Pin 2	Pin 6	Patch
RX	Pin 2	Pin 1	Pin 7	Patch

4. Testing this product

The following program will test the circuit. The test file can be downloaded from www.matrixmultimedia.com.

1. System Setup

MIDI Input / Output Interface

MIDI patch lead

Multi-programmer board (EB006) with:

EB006 Options	Setting
Power supply	External, 14V
PICmicro device	16F877A
SW1 (Fast/Slow)	Don't care
SW2 (RC/Xtal)	Xtal
Xtal frequency	19.6608MHz
Port A	
Port B	LCD board EB005
Port C	MIDI board EB021
Port D	
Port E	
Test program	ConstRX.hex
Test program	ConstTX.hex

EB021 Options	Setting
Patch system	A
J11 VCC Voltage	RIGHT 5V

2. Test Procedure A – MIDI IN and THRU

- 1) Wire power LCD and MIDI boards.
- 2) Configure system and board options as above.
- 3) Connect the MIDI patch lead to the OUT port of the MIDI interface
- 4) Connect the other end of the MIDI patch lead to the IN port of the MIDI E-block
- 5) If you have a second MIDI interface and a second MIDI patch lead you can also test the MIDI through port to check that the MIDI signal is being forwarded correctly
- 6) Download the ConstRX test program to the Multiprogrammer
- 7) Press RESET on EB006 Multiprogrammer
- 8) The LCD E-block should display "Receiving"
- 9) Send some MIDI signals from the MIDI interface and verify that the MIDI messages being displayed on the LCD this proves that the MIDI IN is functional.
- 10) If testing the MIDI Through then make sure that the MIDI signals are reaching the second MIDI interface

Diagram of test solution A

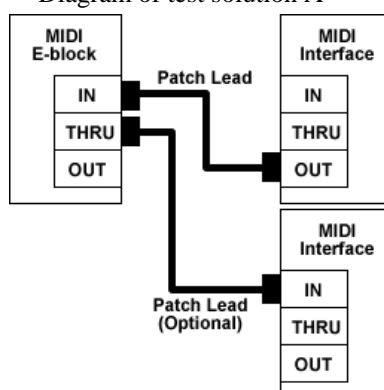

3. Test Procedure B – MIDI OUT

- 1) Disconnect any MIDI patch cables.
- 2) Reconnect the MIDI patch lead to the IN port of the MIDI interface
- 3) Connect the other end of the MIDI patch lead to the OUT port of the MIDI E-block
- 4) Download the ConstTX test program to the Multiprogrammer
- 5) Press RESET on EB006 Multiprogrammer
- 6) The LCD E-block should display “Transmitting”
- 7) The MIDI interface should now be receiving notes getting higher and higher in pitch

Diagram of test solution B

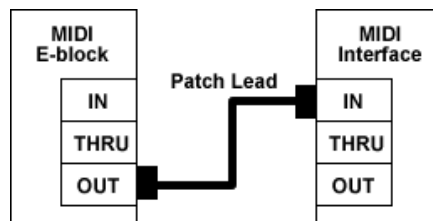

Test procedures A and B test the complete functionality of the board

5. Circuit description

The circuit as can be seen in the circuit diagram below (See Appendix 1 – Circuit diagram), made up of three sections: Connectors, Optical Isolator and Logic Buffering.

1. *Connectors*

The design of this product is to enable you to use it with many standard PICmicro® microcontroller devices. This is achieved by identifying the PICmicro® that you are using and which input output pins are available. Depending on which I/O pins are free you can configure the jumpers on the MIDI board to route access to the RX and TX control lines. (see section 3 for jumper guide)

The Patch System allows the user to route RX and TX to any 8 of the bits that they require. This allows great flexibility.

2. *Optical Isolator Circuit*

The Optical Isolator chip that is used is a 6N138. It contains an active light emitting diode and a light dependant sensor. Used together these components act to convert the electrical signal coming into the MIDI IN port into a light based signal and then back into an electrical signal. This method of converting the signal medium is very useful as it firstly prevents earth loops that would incur oscillations within the signal and secondly as it helps to prevent the PICmicro® become damaged from incorrect wiring or over current.

3. *Logic Buffering*

The logic buffer chip that is used is a 74HC00 and is made up of four standard NAND gates. The buffer chip is important for the circuits operation as it provides a way of double buffering the output to the MIDI OUT and the MIDI THRU. This helps boost the current of the signal making the signal stronger at the remote end allowing for easier reception.

4. *3.3V operation*

The MIDI Board is not 3.3V compatible. However users can ask for a MIDI board fitted with extra circuitry, which allows for 3.3V compatible operation.

