

SEED TECHNOLOGY INC (SEEEDUINO) Electronic brick - PIR motion sensor(digital) Model: ELB106C5M

Introduction

This brick includes a PIR motion sensor module, Max sentry distance is 7 meters. If anyone moved in that range, Alarm pin will go high. The signal duration can be adjusted from 0.3s-18s by the yellow potienmeter.

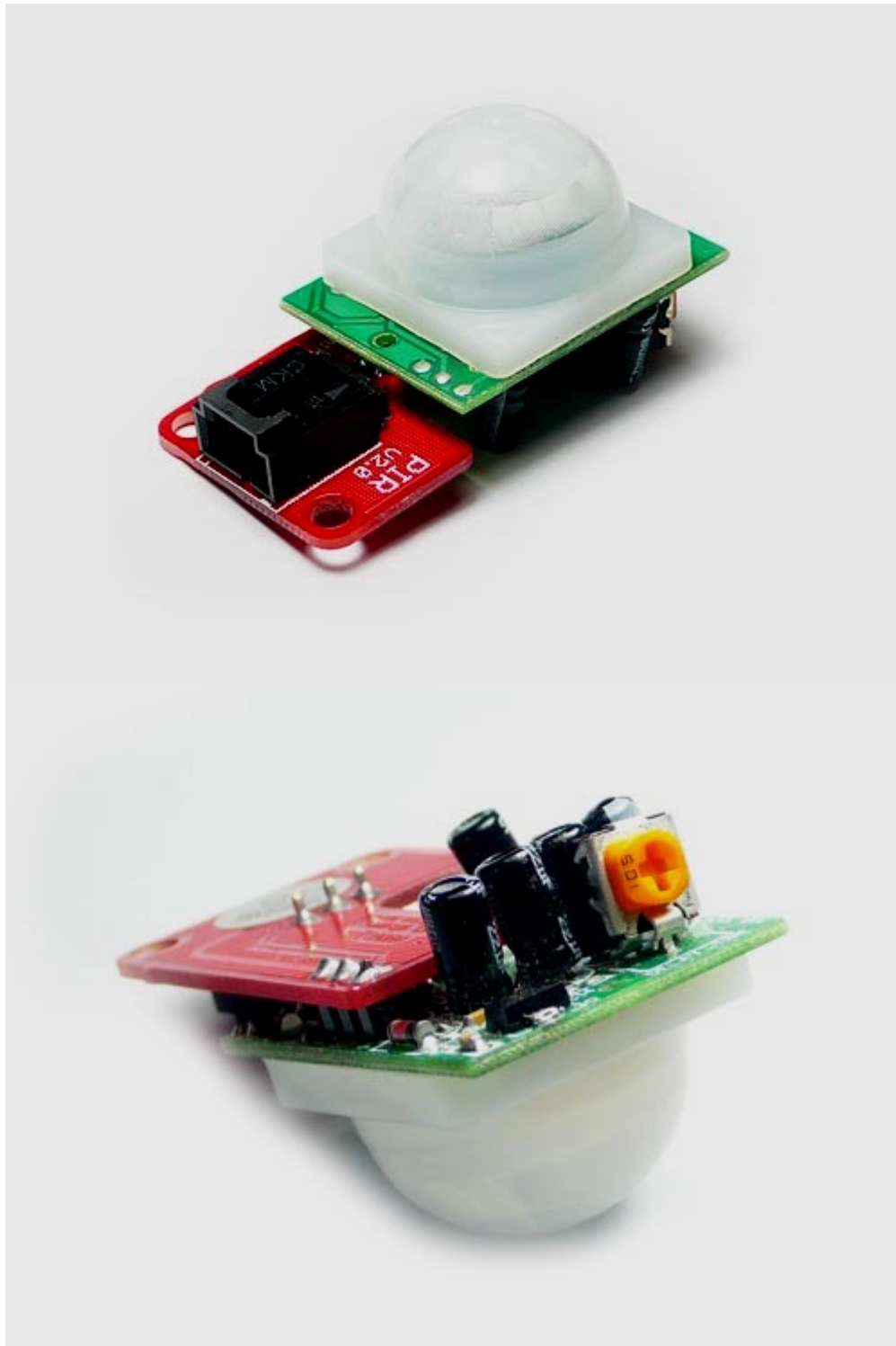

Electronic Bricks?

Yes! We can build electronics projects just as easy as piling bricks. Arduino and community have made the programming much easier than ever before. How about some elixir on hardware part? Maybe it is not yet convenient to make complex interfaces, but we can at least start from the most commonly used modules.

By using electronic bricks, you may connect Arduino compatible boards easily with various digital, analog and I2C/Uart interfaces. These the breadboard-less firm connection are prepared to extensive modules like potentiometers, sensors, relays, servos...even buttons, just plug and play.

Each terminal module has buckled port with VCC, GND and Output, which has corresponding port on the sensing board, with a plain 2.54mm dual-female cable you may start playing already. Buckled brick cables are like cement for bricks, make the connections easier, secure and more professional looking.

Electronic Brick Series

- Arduino Sensor Board Explained.

Easy
Reliable

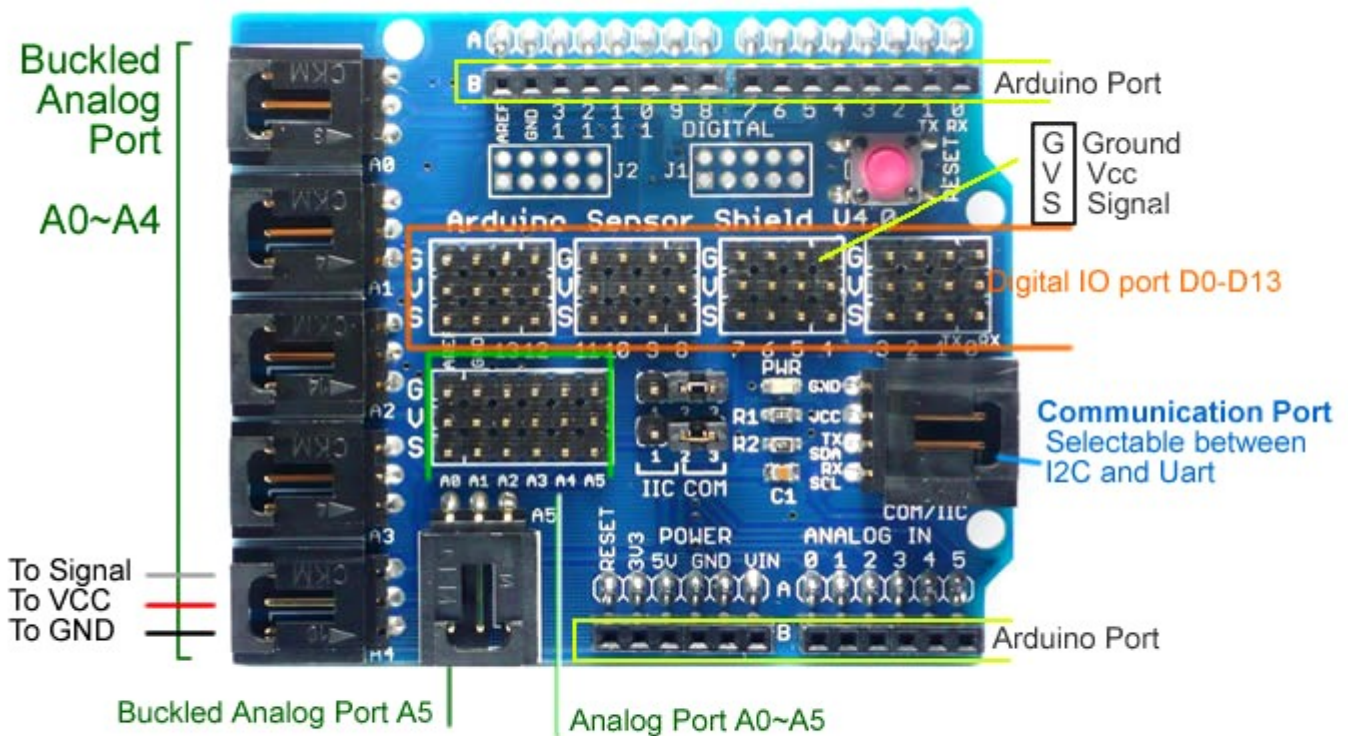

- Buckled Analog Port - Easy, Solid connection with Analog input with VCC/GND.
- Buckled Communication Port - Easy communication port with I2C and Uart
- Digital IO port - Standard servo pin compatible,
- Analog IO port - 2.54 grid male pin header connections

Features

- feature1
- feature2
- feature3

Application Ideas

- Application1
- Application2

- Application3

Cautions

The warnings and wrong operations possible cause dangerous.

Schematic

It is the schematic, the circuit about Eagle resource like .pdf should linked here in order to avoid memory exhausted.

Specification

May include key specification and other specifications.

Pin definition and Rating

Mechanic Dimensions

Usage

Hardware Installation

These bricks are working with Arduino sensor shield:

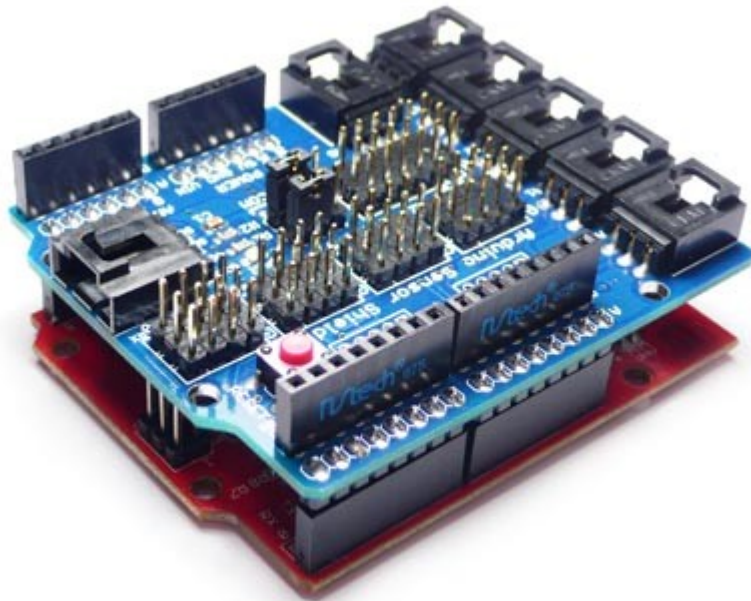

Programming

Includes important code snippet. Demo code like :

```
Demo code  
{  
  
}
```

Example

The projects and application examples.

Bill of Materials (BOM) /parts list

All the components used to produce the product.

FAQ

Please list your question here:

Support

If you have questions or other better design ideas, you can go to our [forum](#) or [wish](#) to discuss.

Version Tracker

Revision	Descriptions	Release
v0.9b	Initial public release	Aug 04, 2009

Bug Tracker

Bug Tracker is the place you can publish any bugs you think you might have found during use. Please write down what you have to say, your answers will help us improve our products.

Additional Idea

The Additional Idea is the place to write your project ideas about this product, or other usages you've found. Or you can write them on Projects page.

Resources

The resources need to be downloaded, like Eagle file, Demo code, project or other datasheet.

See Also

Other related products and resources.

Licensing

This documentation is licensed under the Creative Commons [Attribution-ShareAlike License 3.0](#) Source code and libraries are licensed under [GPL/LGPL](#), see source code files for details.