



ORION

ROBOTICS

Fire Ant Assembly Guide

Introduction

All Orion Robotics brackets are made in the USA. We fabricate them using a large in-house industrial laser. We anodized our brackets to prevent oxidation. This gives the bracket a much better look and longer life.

Servos

The Orion Robotics robots are built around special robotics servos we developed. Our servos are custom manufactured and assembled in the USA. Our robotic servos allow us to create unique features for each of our robots.

Tools

There are some basic tools you will need to get started. A good set of Phillips screw drivers and small pliers. Different sized screws are used throughout each robot. So more than one size Phillips is a good ideal.

Safety

When working with robots some basic safety rules should be followed:

1. Eye protection should be worn at all times.
2. Some bracket edges can be sharp and can easily cut you.
3. The robots are powered from lithium polymer, or Li-Po, batteries with high discharge rates. If shorted or incorrectly connected they can easily cause fire or other damaged.
4. The servos in these robots are high power and can easily cause injury. Make sure you are clear of the robot on first power up or during operation.
5. When working with the robots there are several pinch points. Be aware as this will hurt if you get caught in them.
6. Don't be in a rush when assembly your robots. Injury or damaged parts can easily result. Take your time and double check each step.

Servo Setup

If you are using the Orion Robotics HV220 Digital Servo, it has a range of $\pm 100^\circ$ of rotation CCW and CW from the center. Each servo should be set for maximum range of motion on each joint before final installation. Any robot part that is attached to a servo disc should be set to the proper angle so the range of motion is not limited.

If you are using the Orion Robotics HV220R Advanced Digital Servo, it has a full 360 degree rotation capability and always has maximum range of motion. No special adjustments are necessary before final installation.

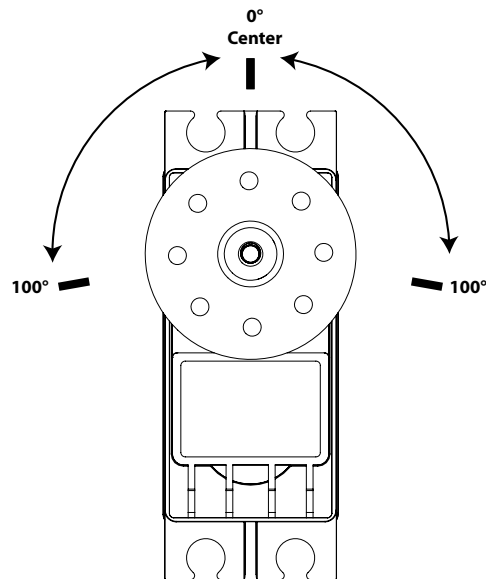

Orion Setup

Set all the VS / VCC jumpers to VS. This puts the main input voltage (VIN) on the servo power pin. For most configurations wire the main battery to GND / S+. Make sure JP6 are jumpered in the correct orientation. JP6 combines the logic power and servo power. This minimizes wiring. In some applications you may need to supply a separate logic battery. This is caused by the servos drawing too much power for a brief period and the battery drops out. Which then causes logic to reset. This will not usually happen when using Li-Po batteries. If you use NiMH batteries you may need the separate logic battery.

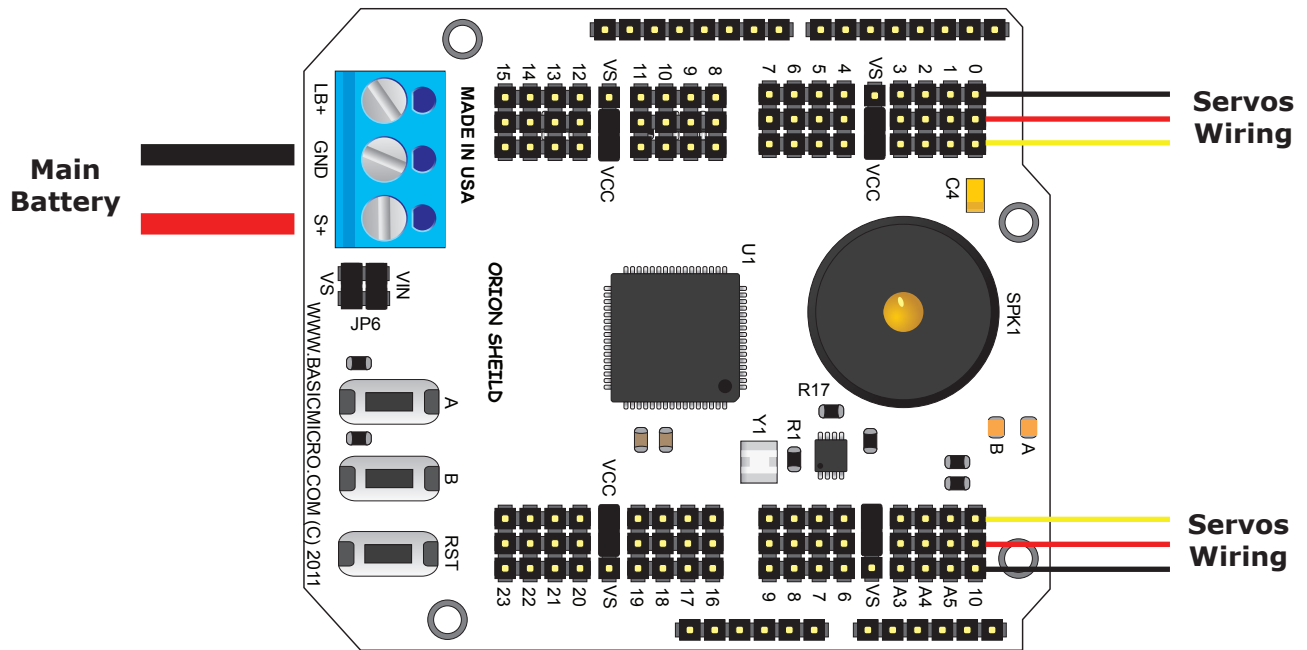

STEP

1

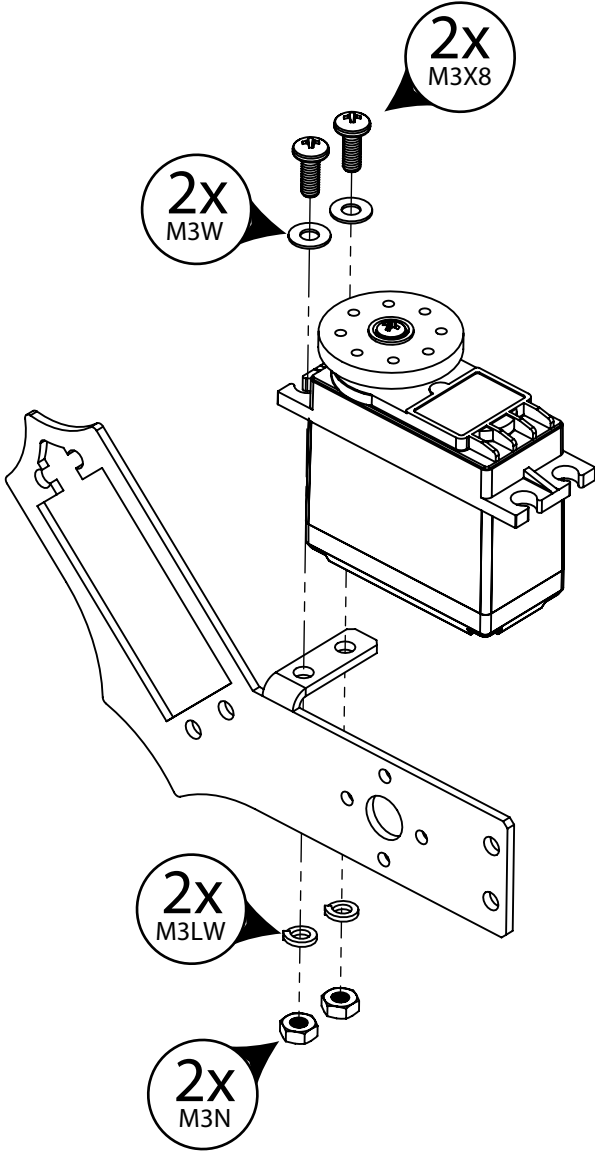

STEP 2

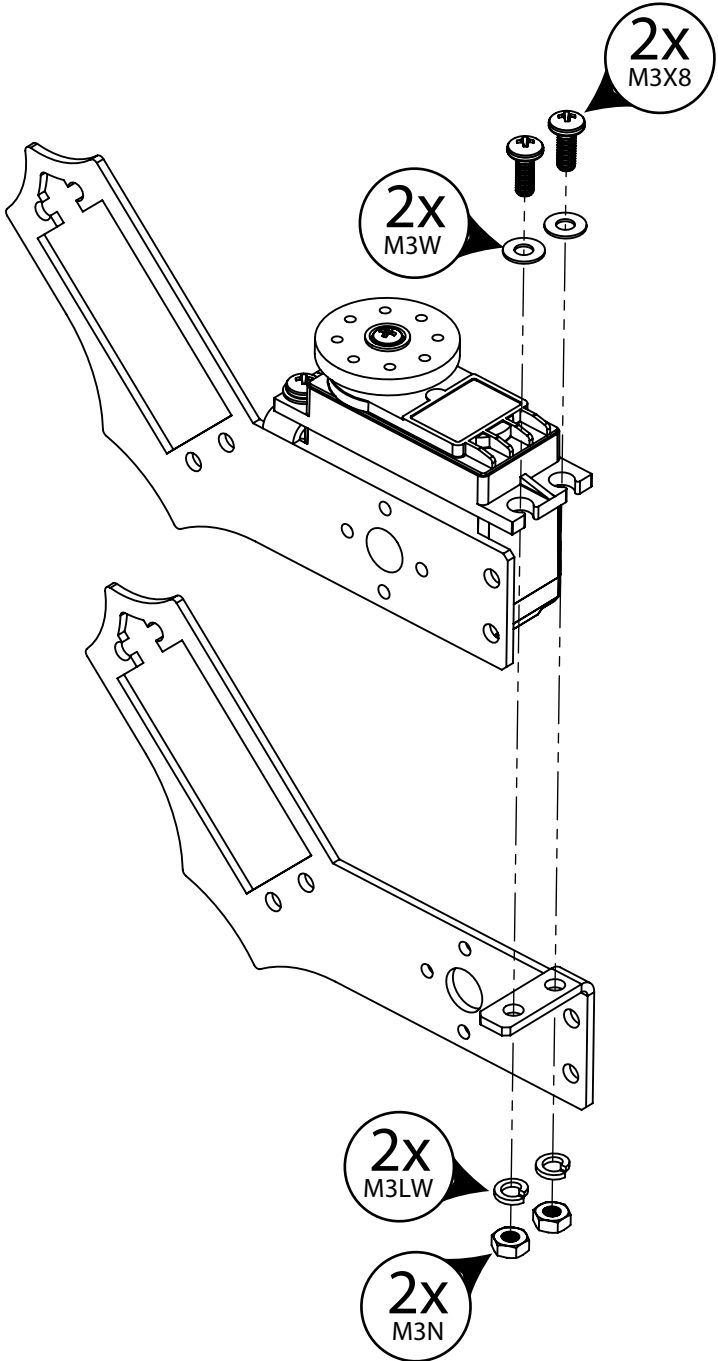

STEP

3

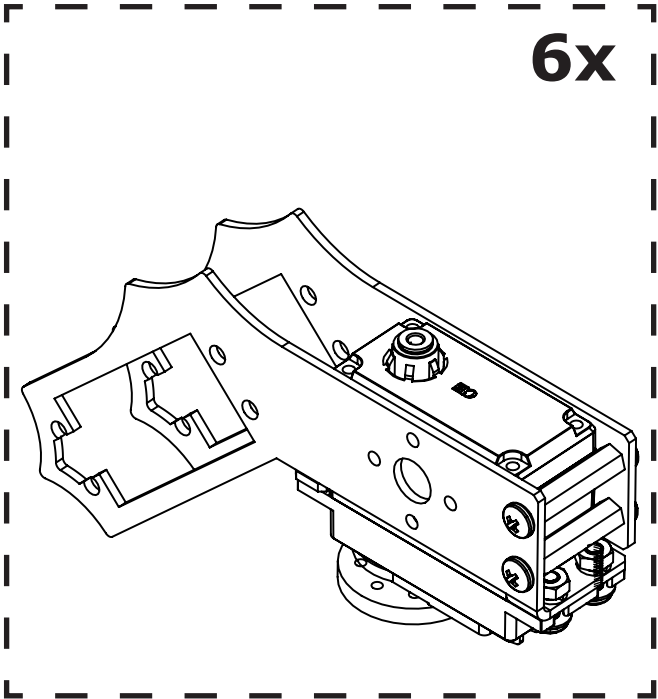
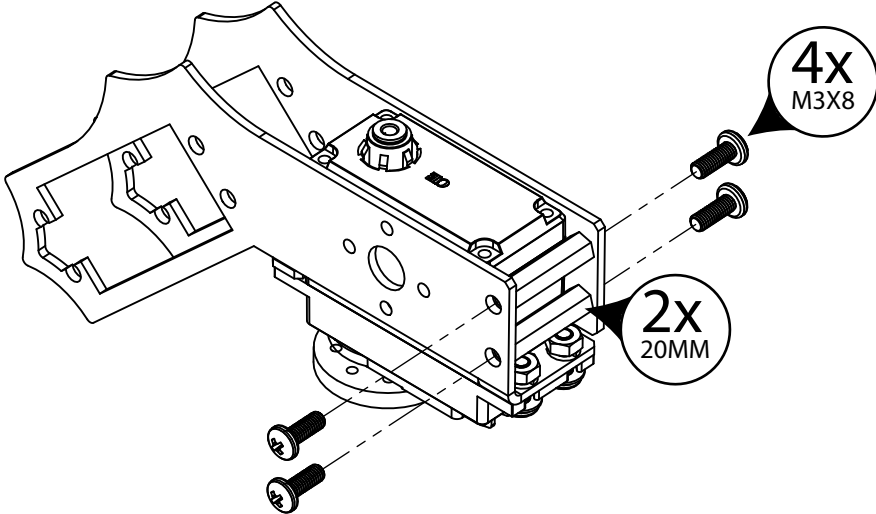

STEP

4

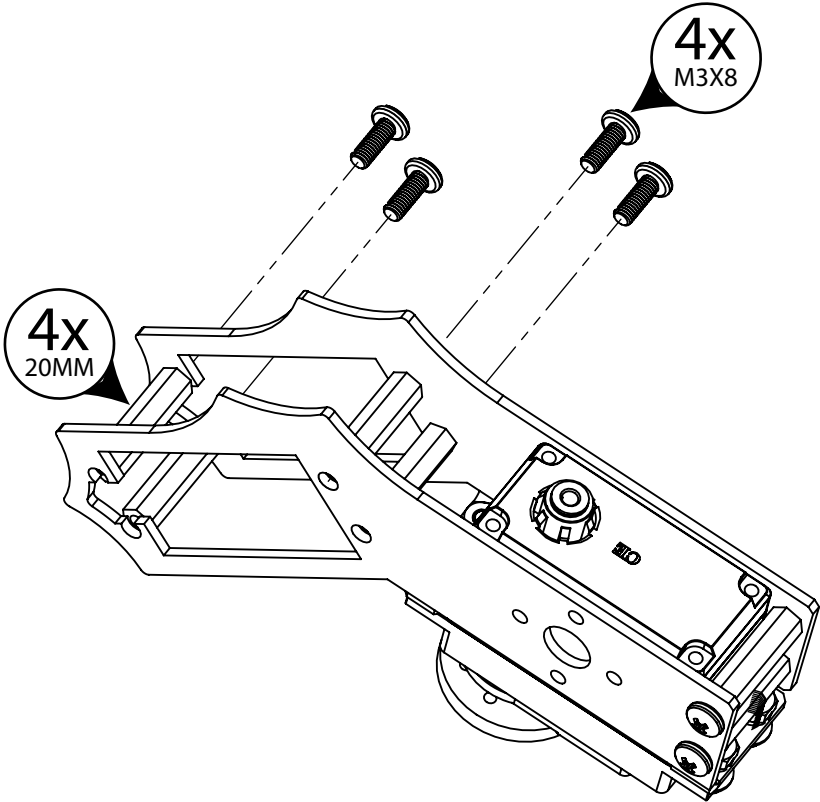

STEP

5

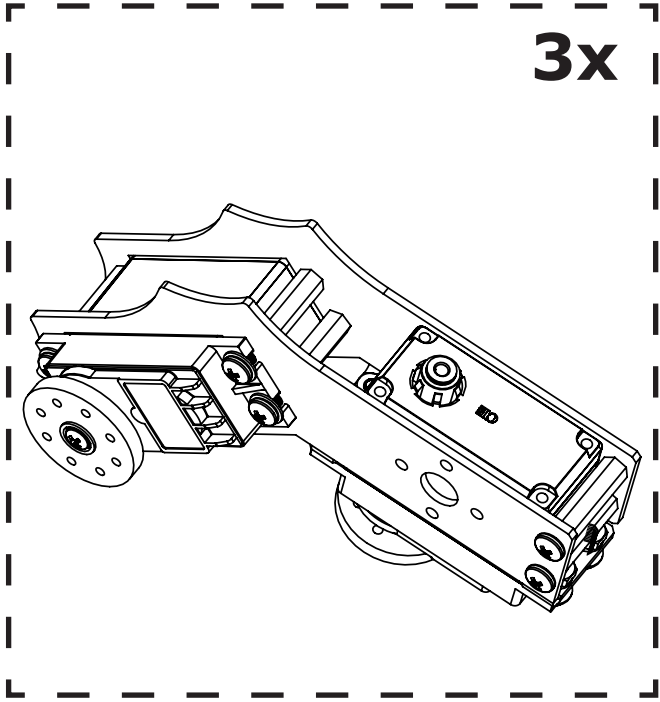
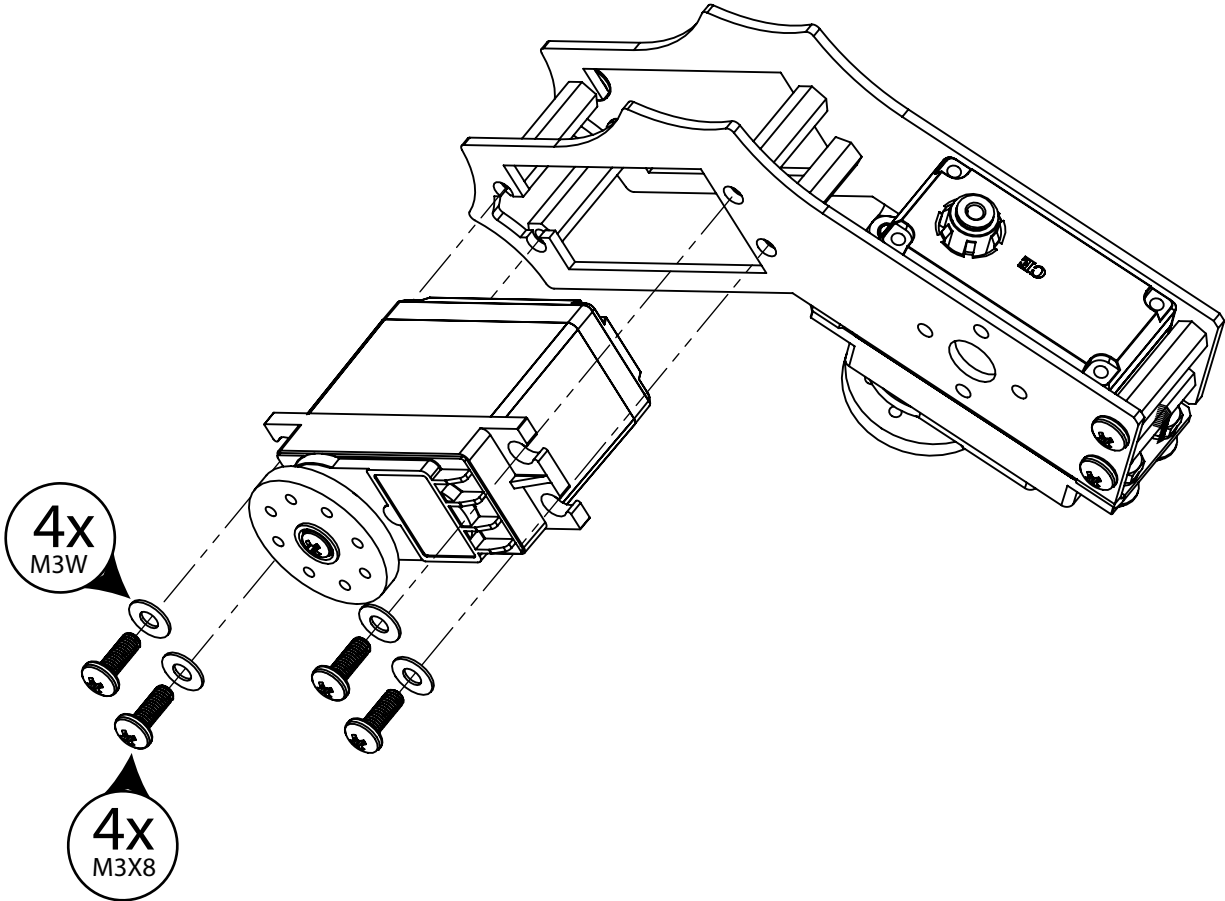

STEP 6

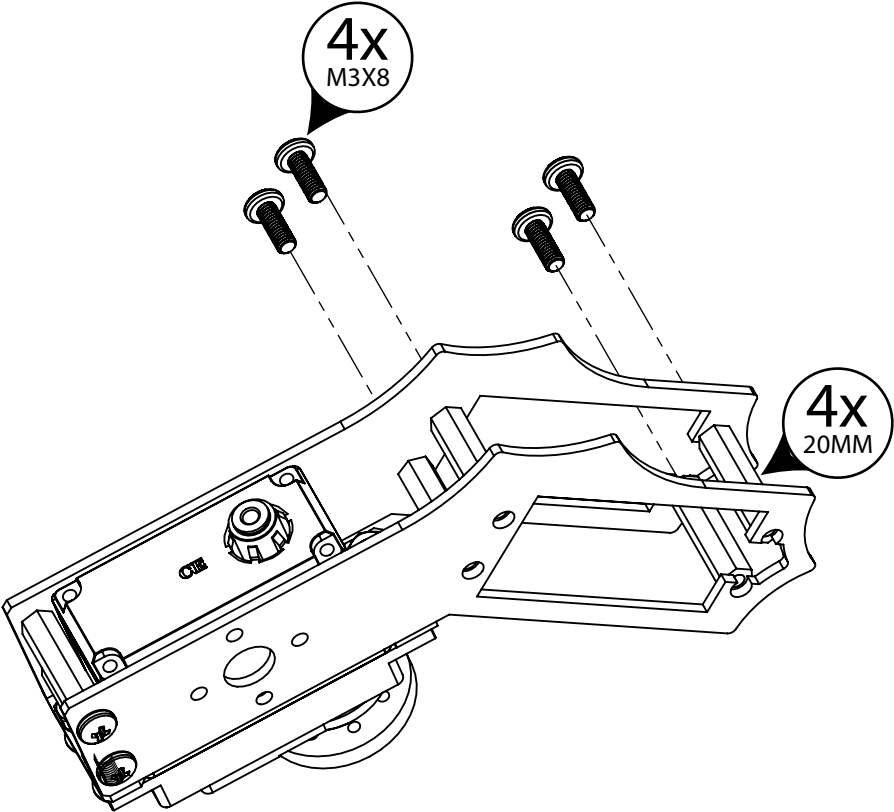

STEP

7

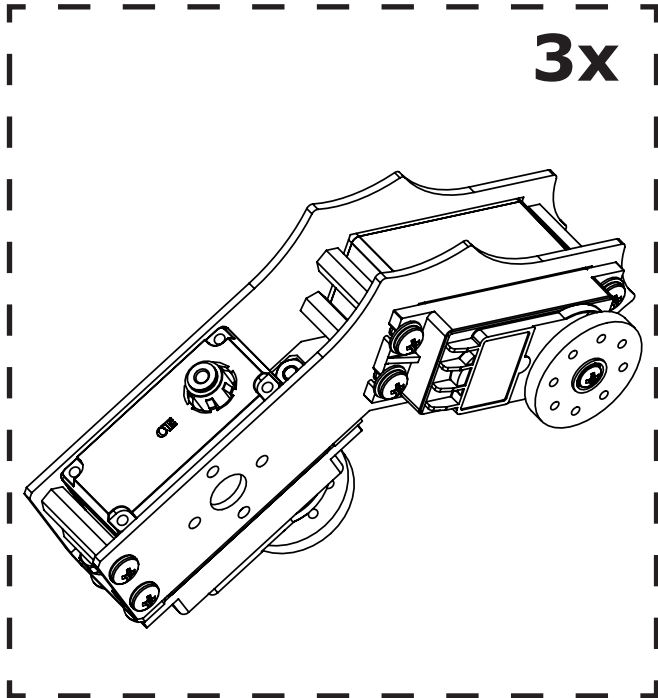
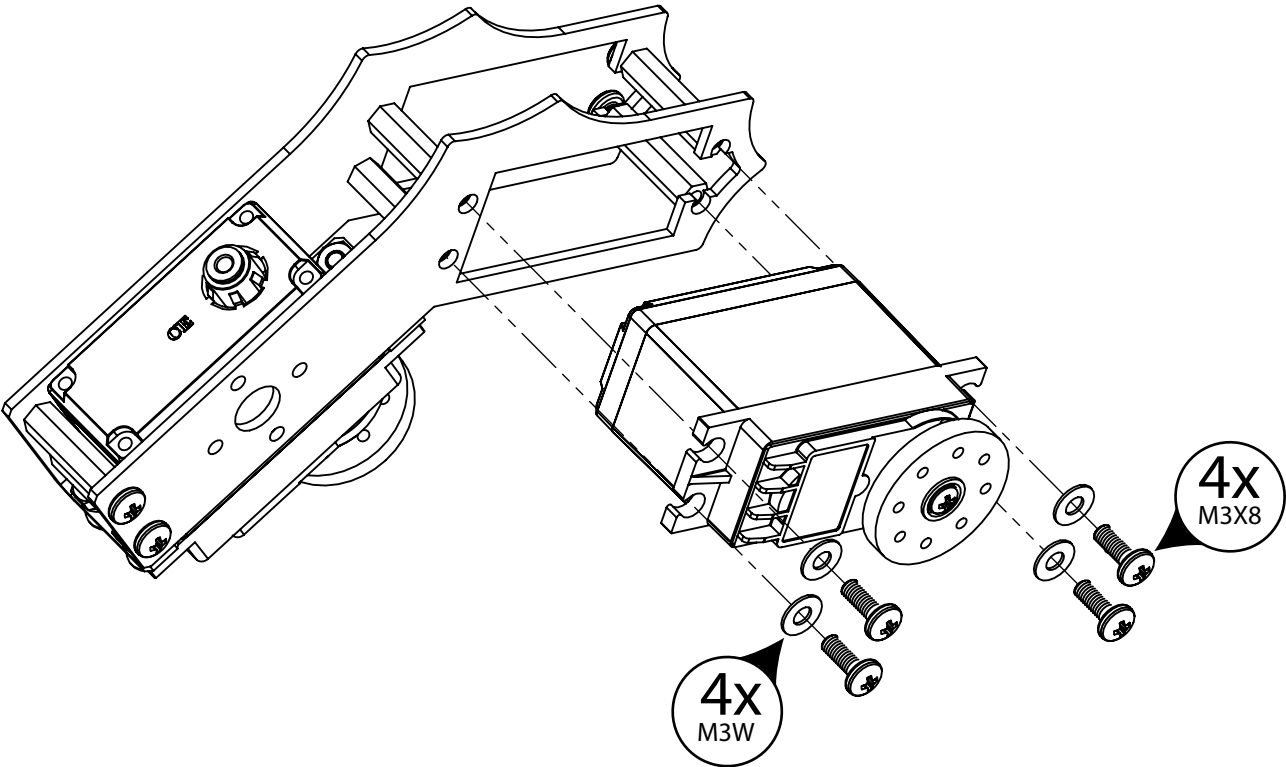

STEP 8

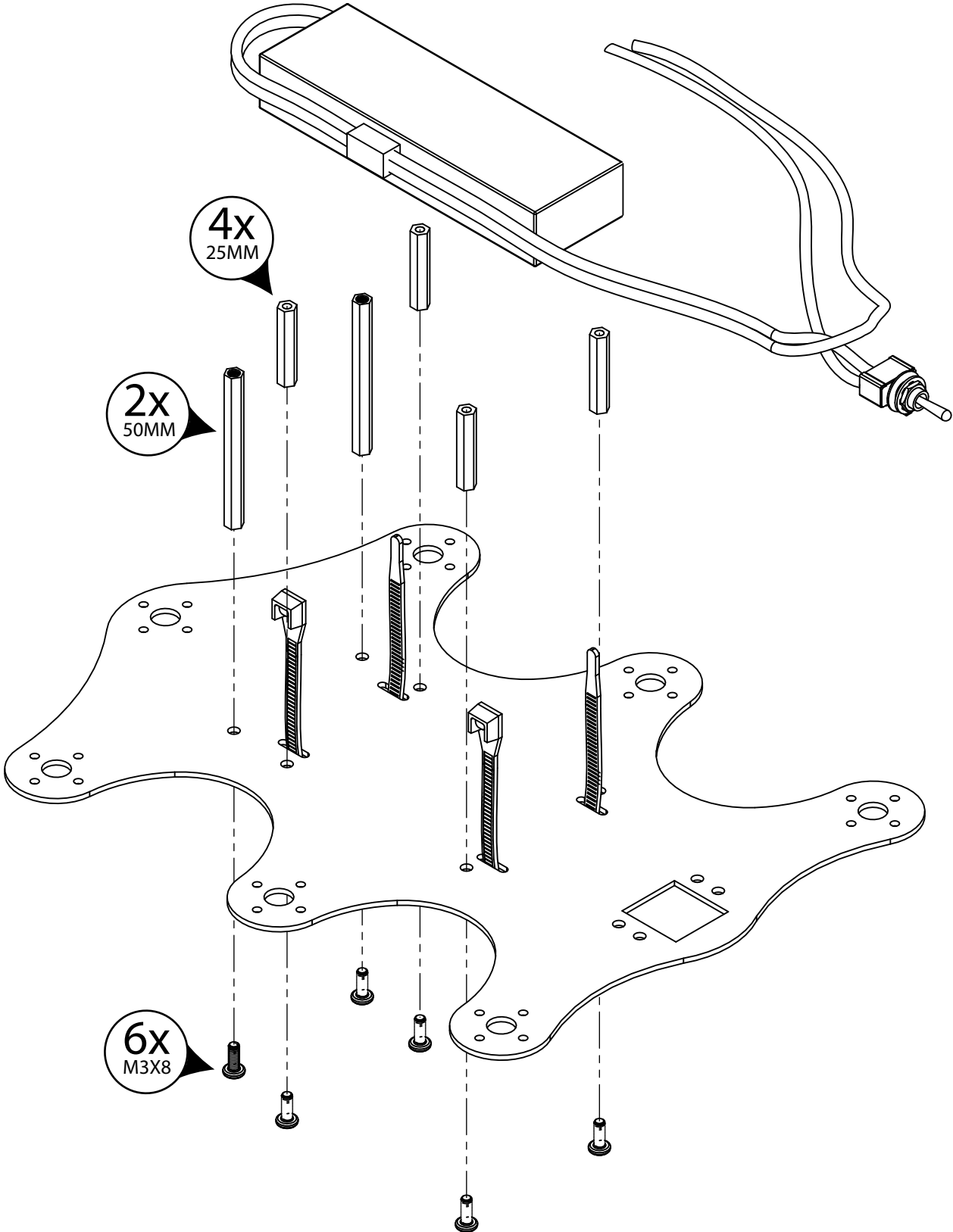

STEP 9

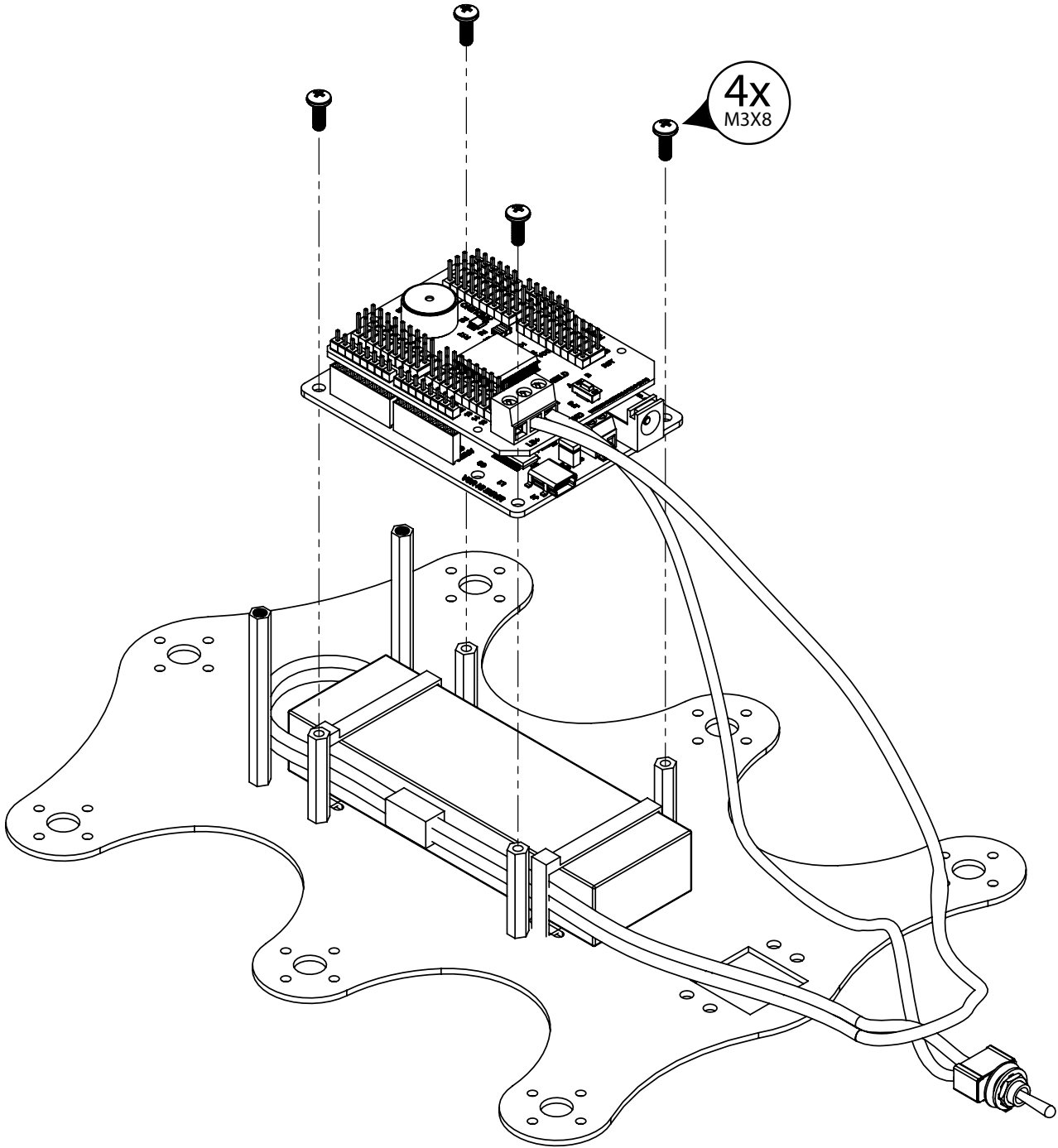

STEP

10

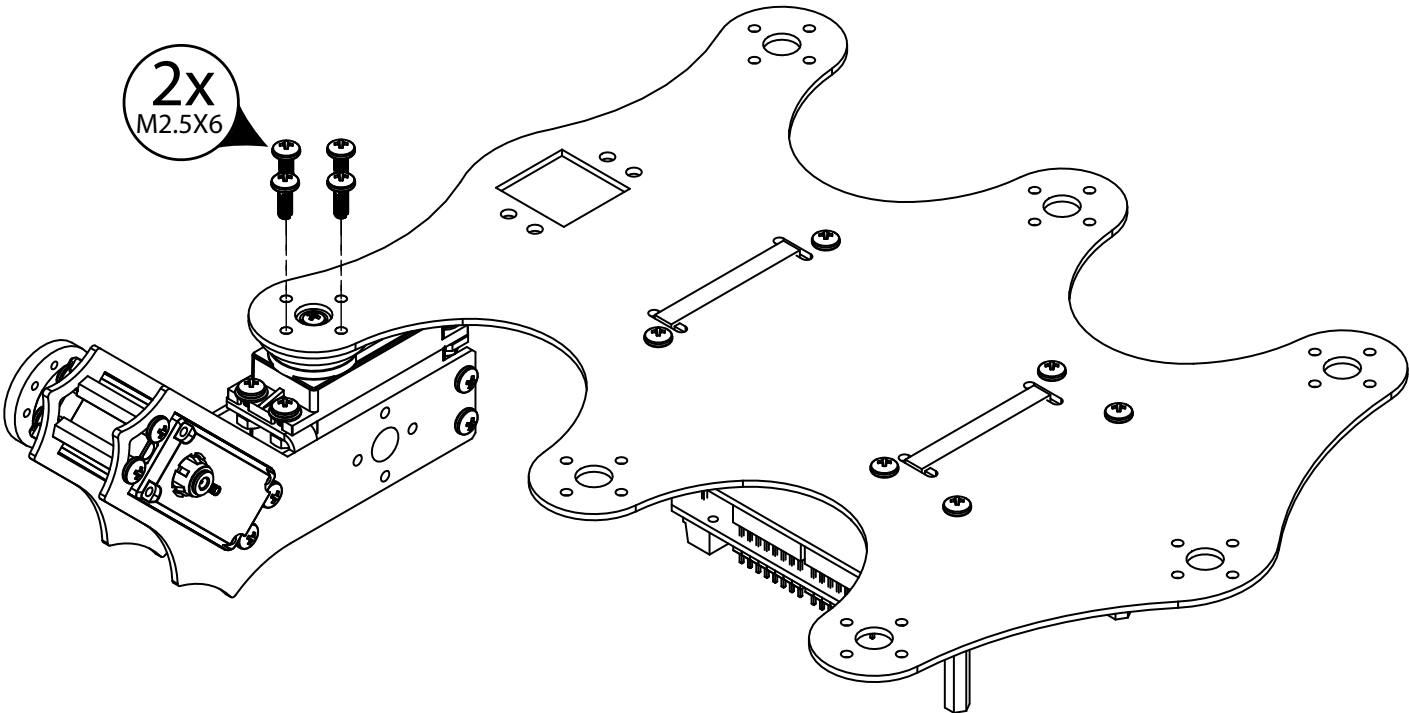

STEP

11

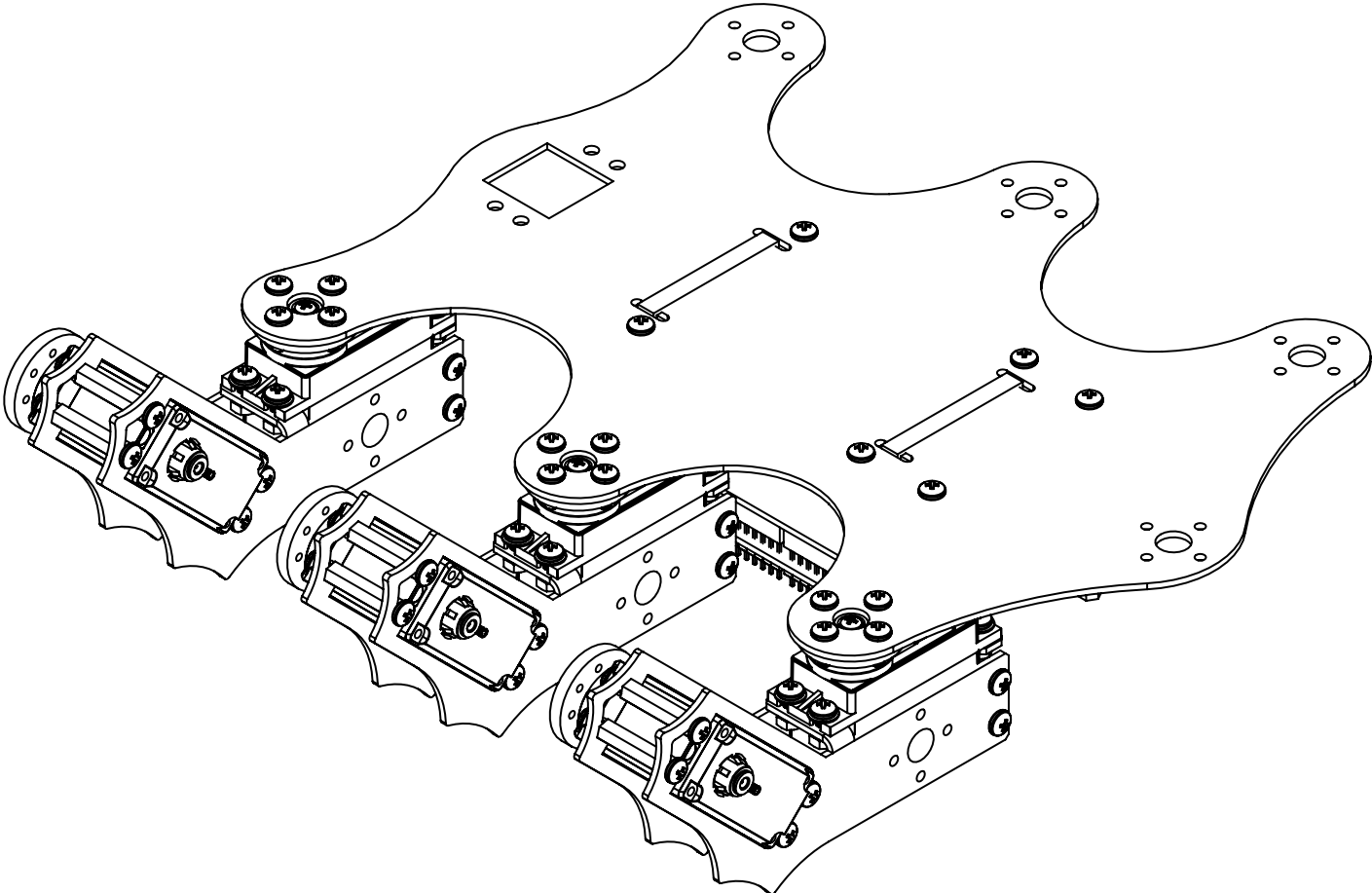

STEP

12

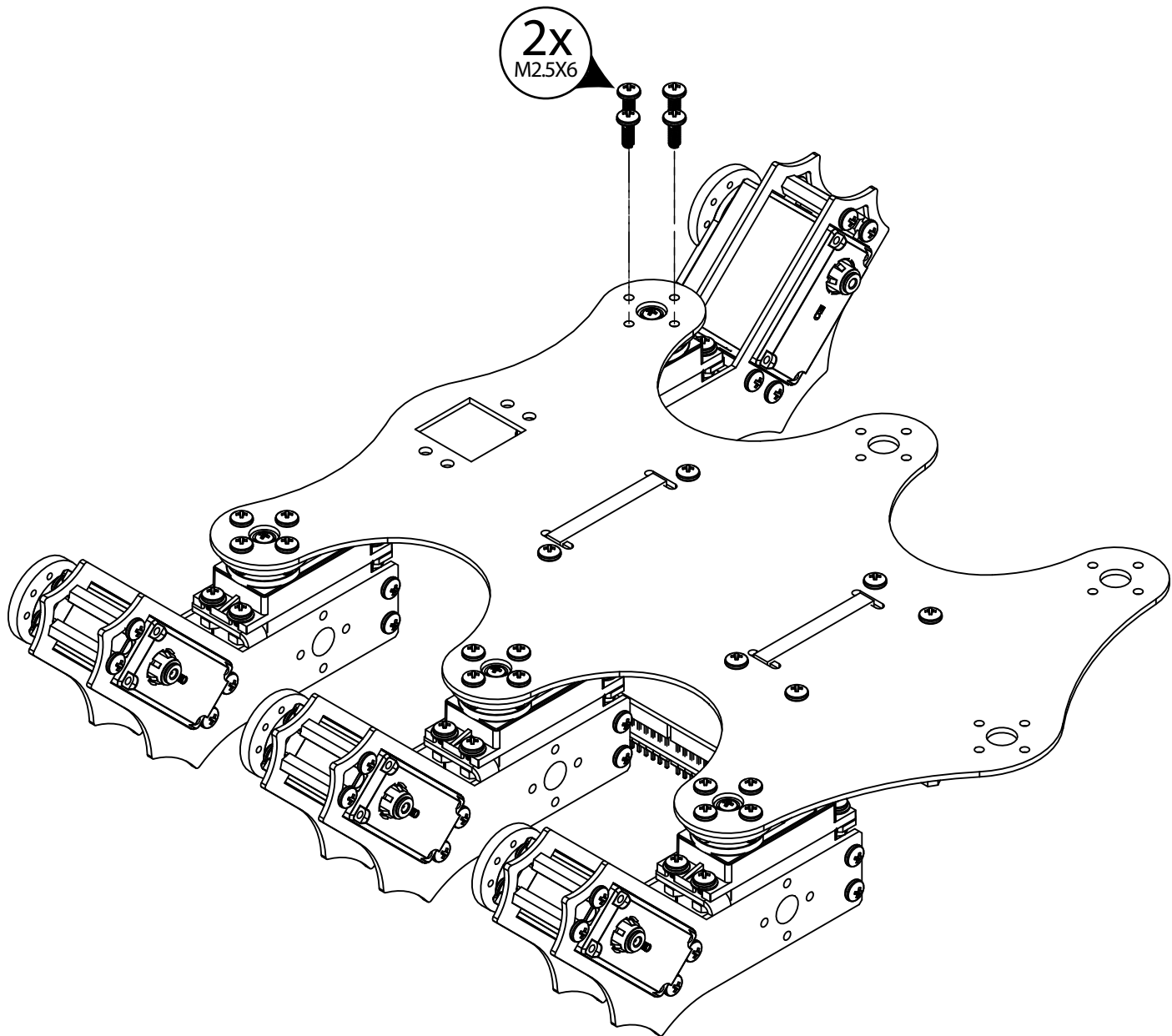

STEP

13

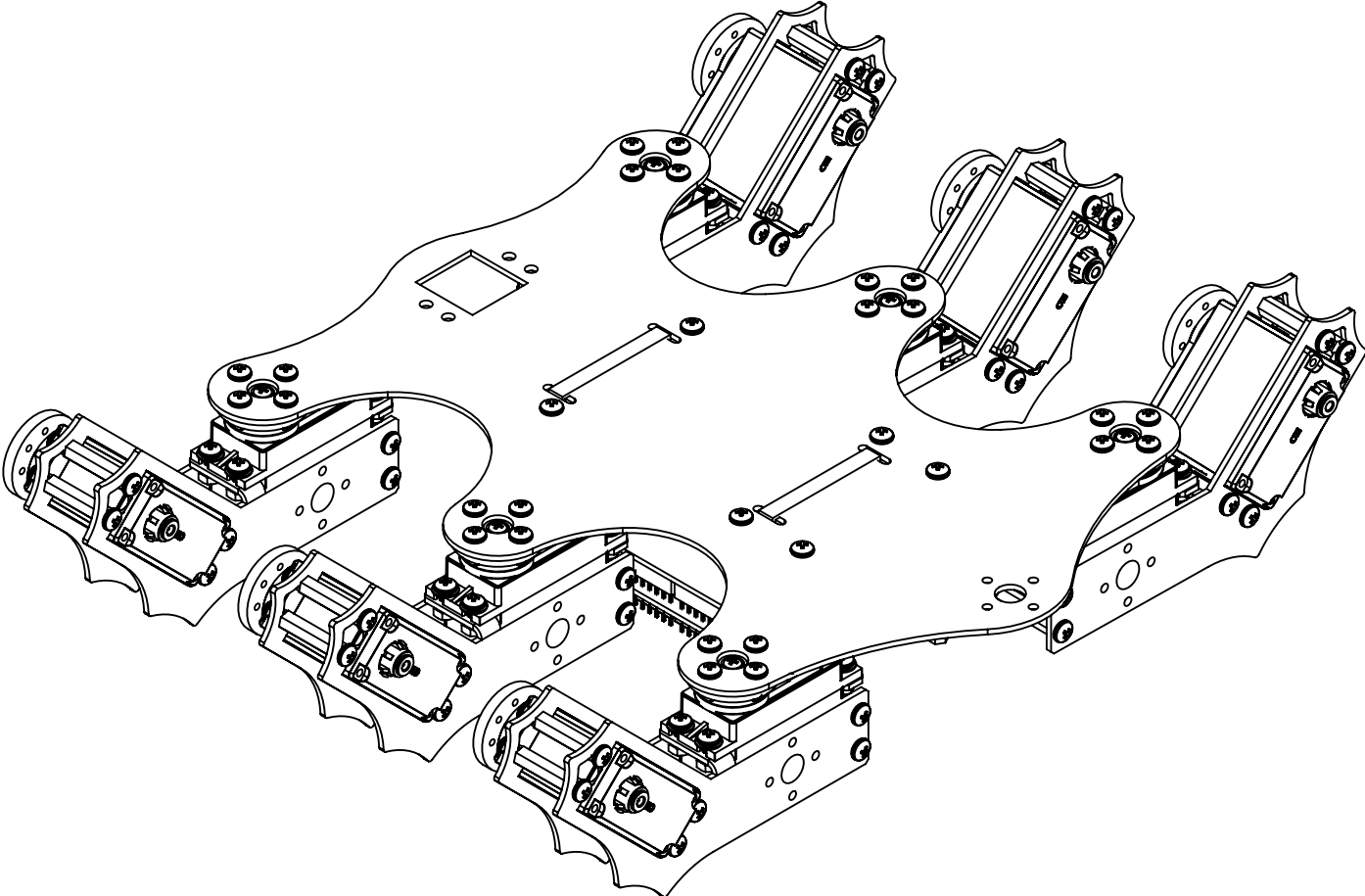

STEP

14

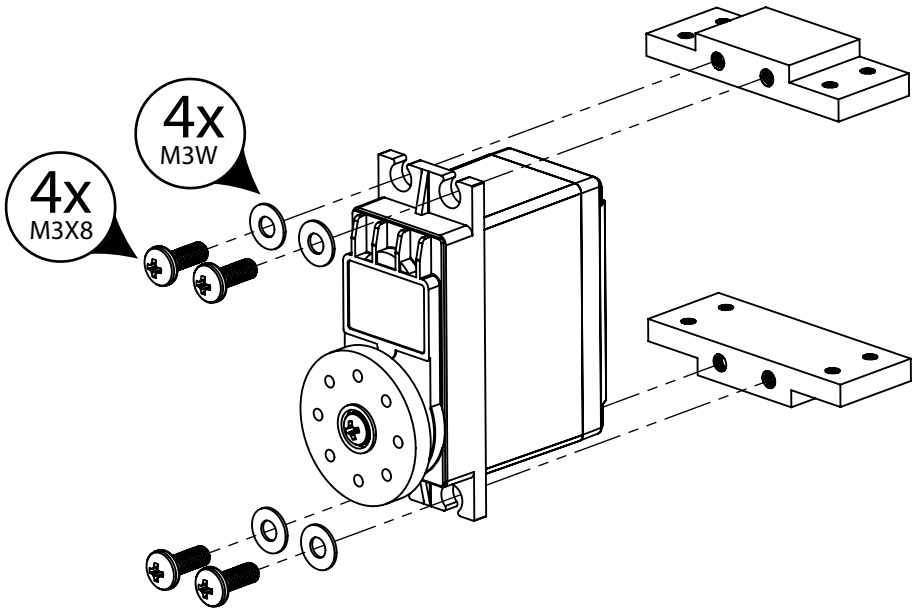

STEP

15

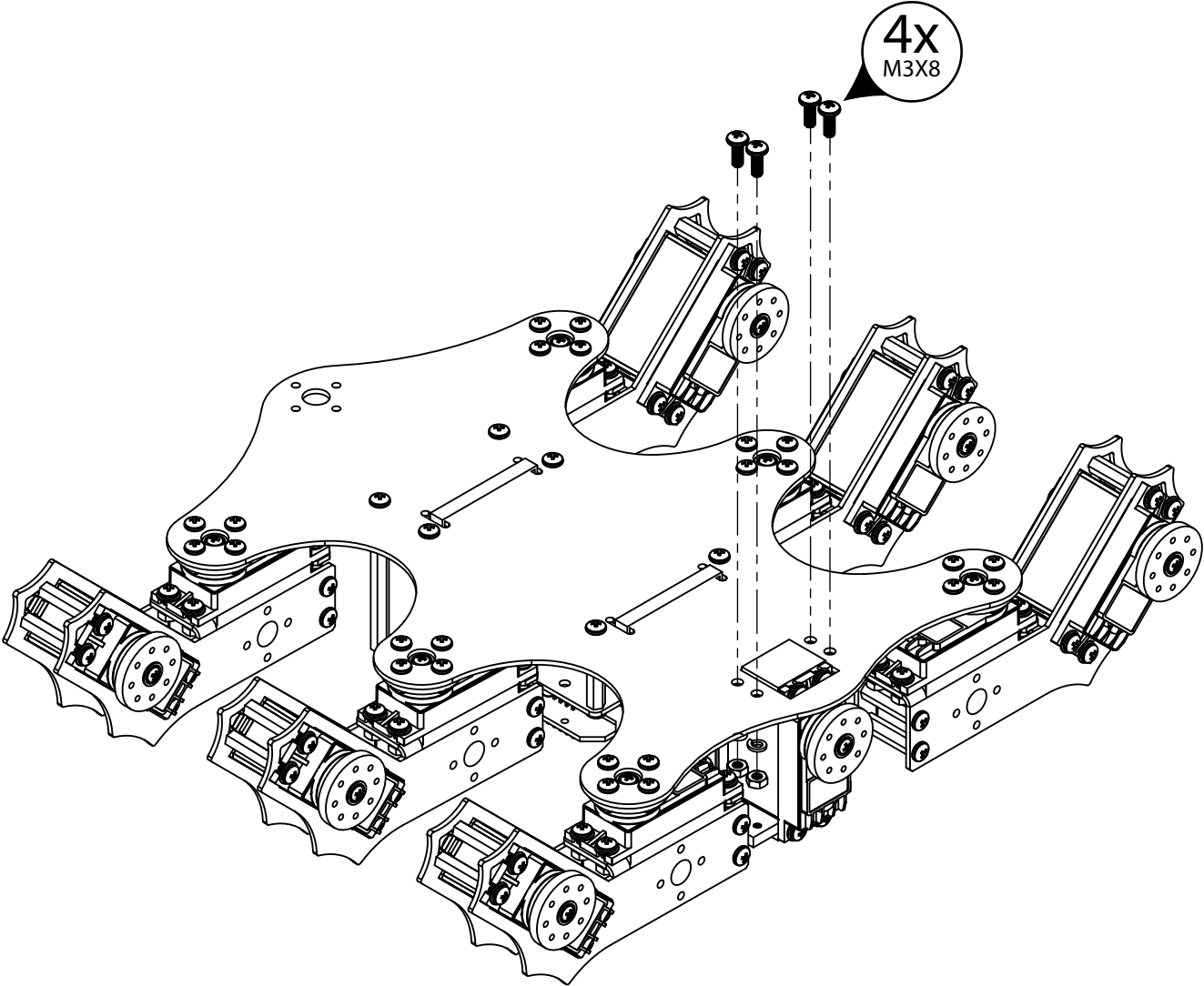

STEP

16

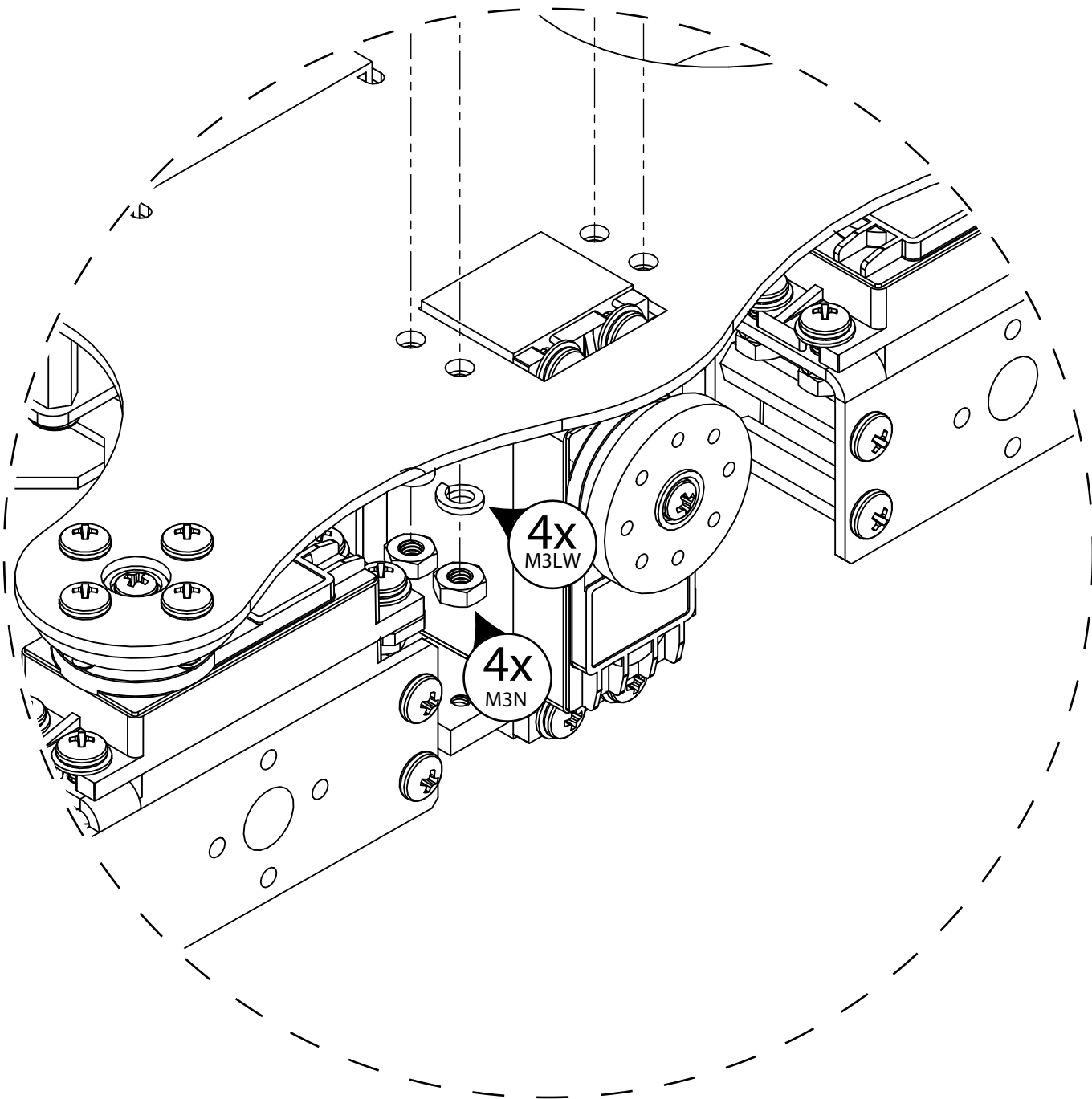

STEP 17

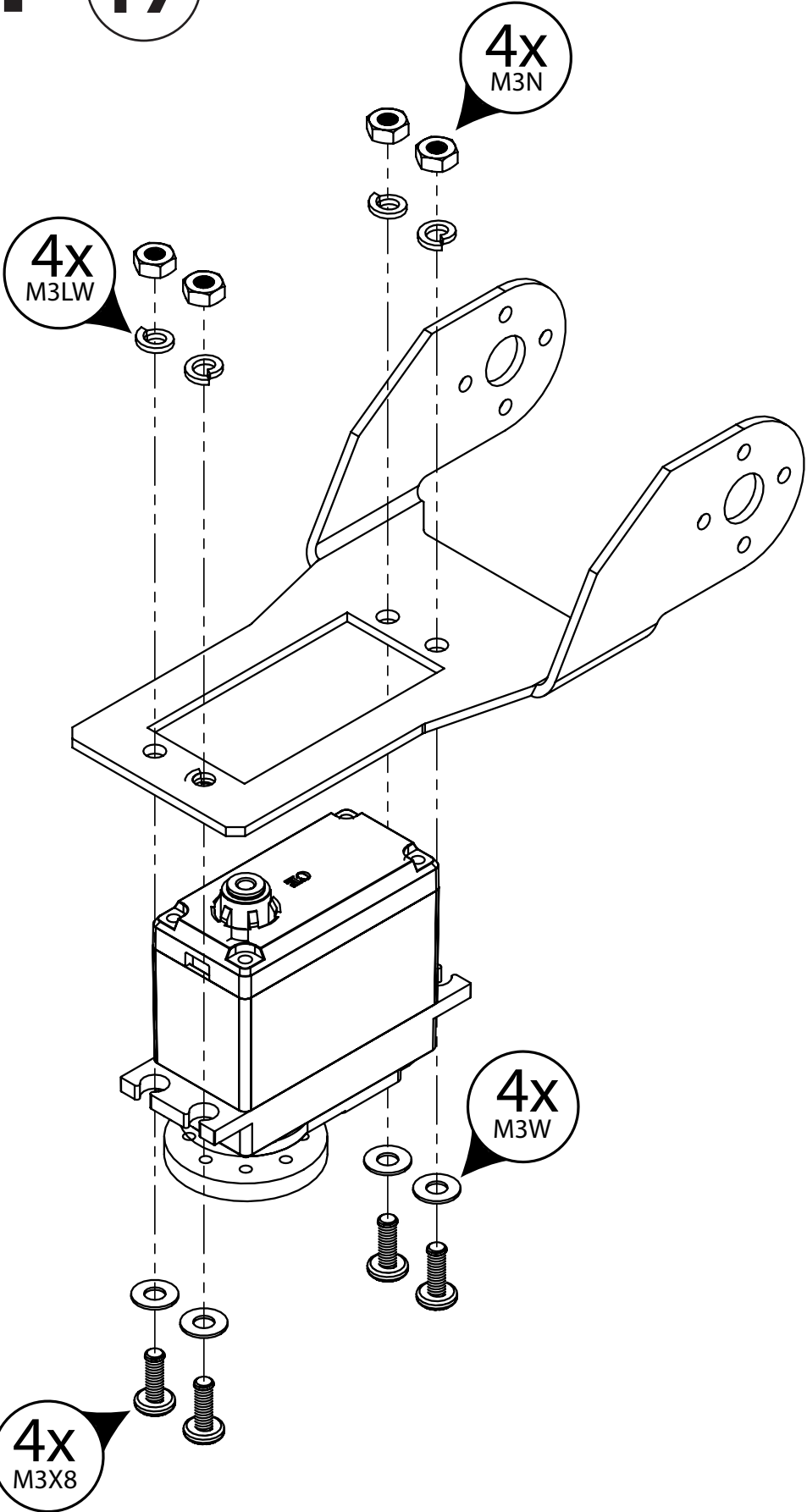

STEP

18

4x

M2.5X6

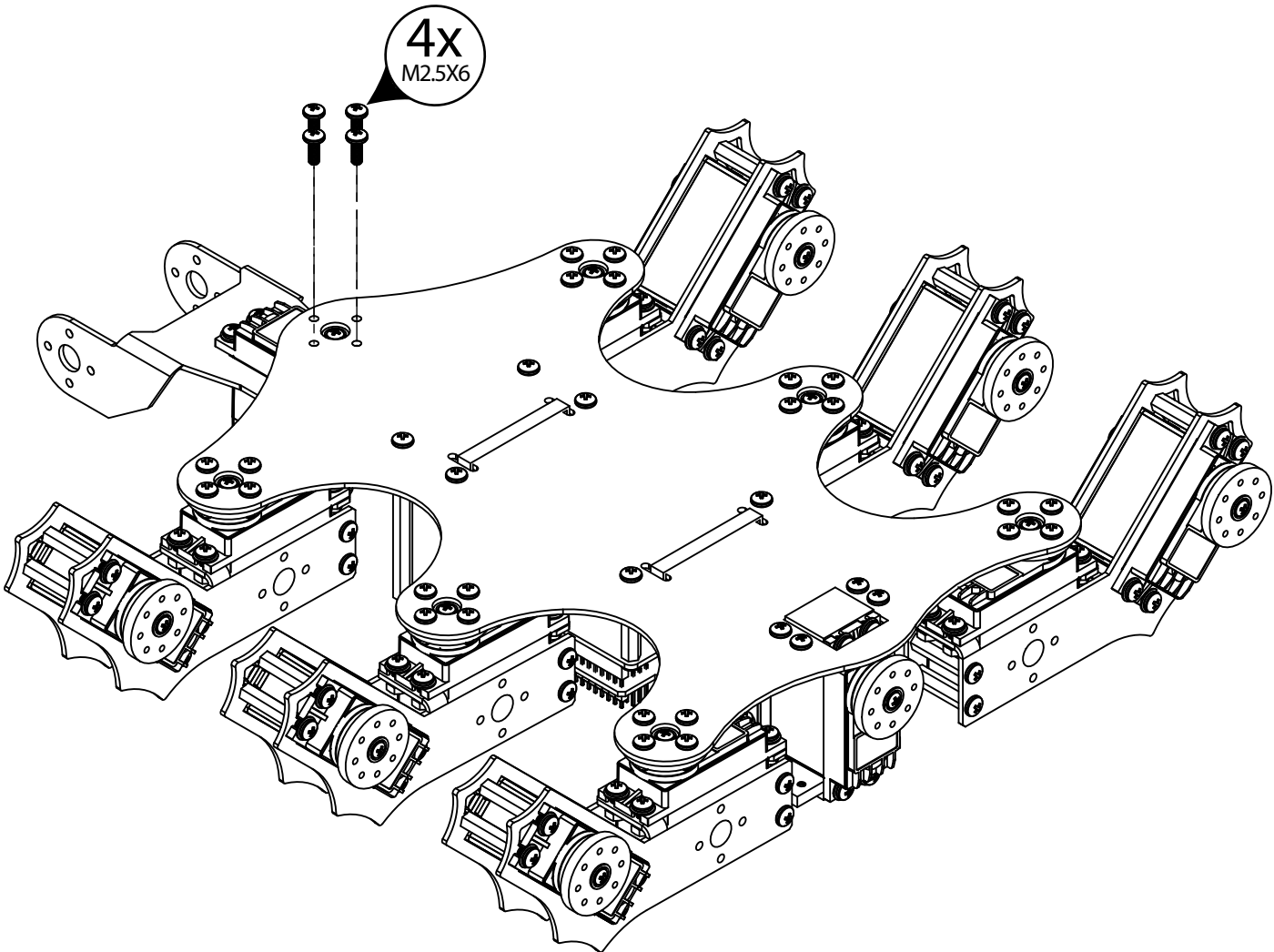

STEP

19

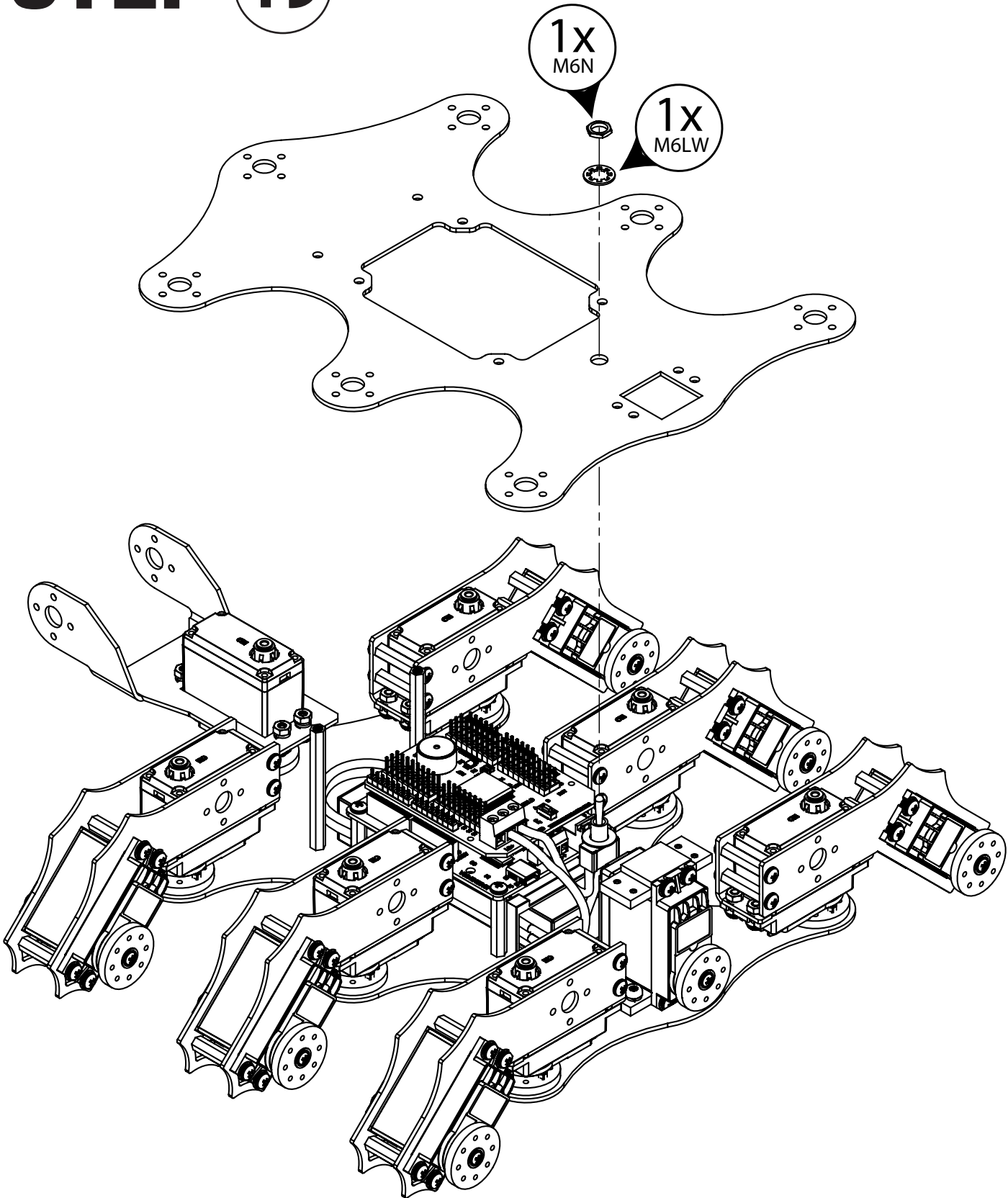

STEP

20

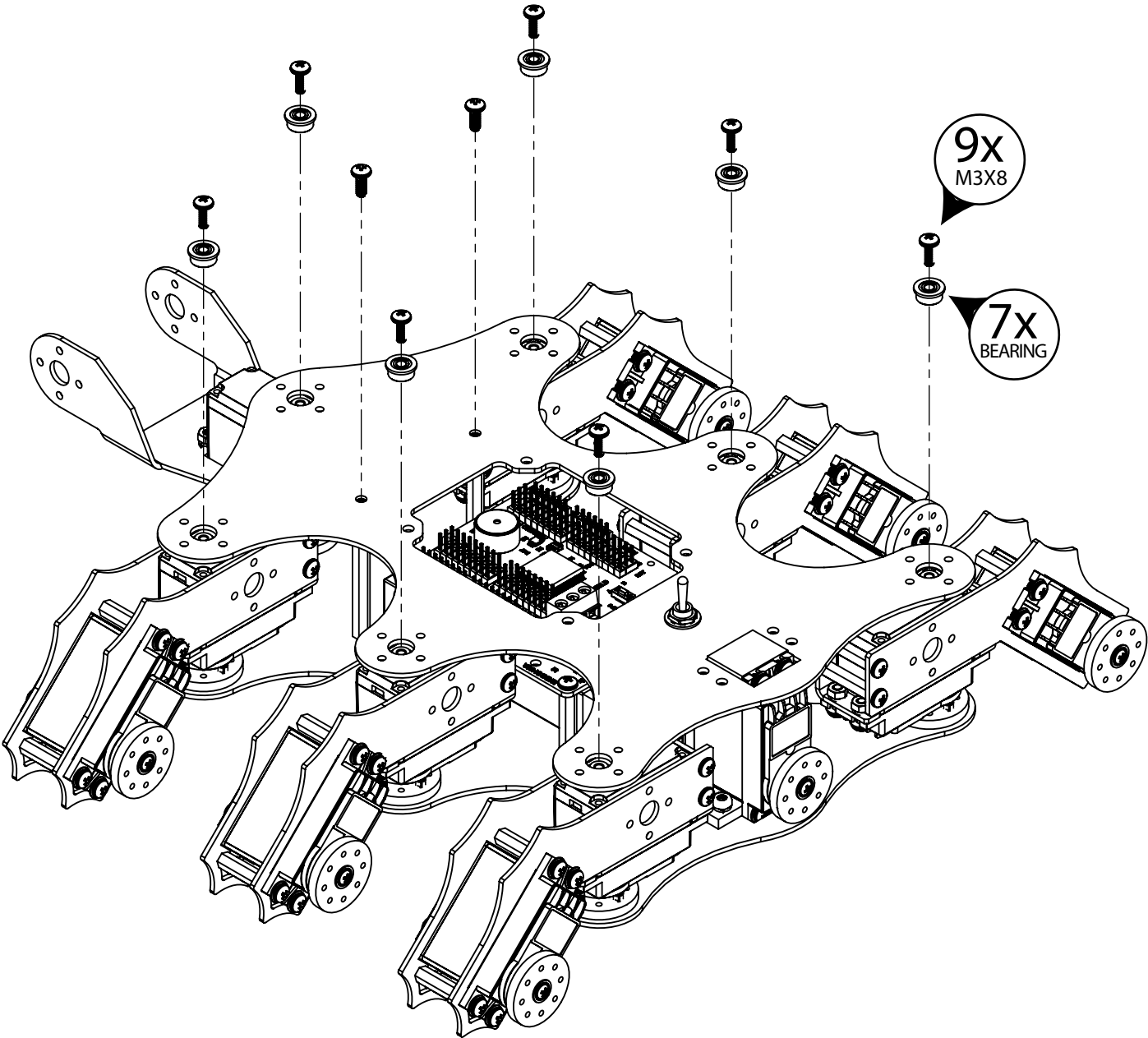

STEP

21

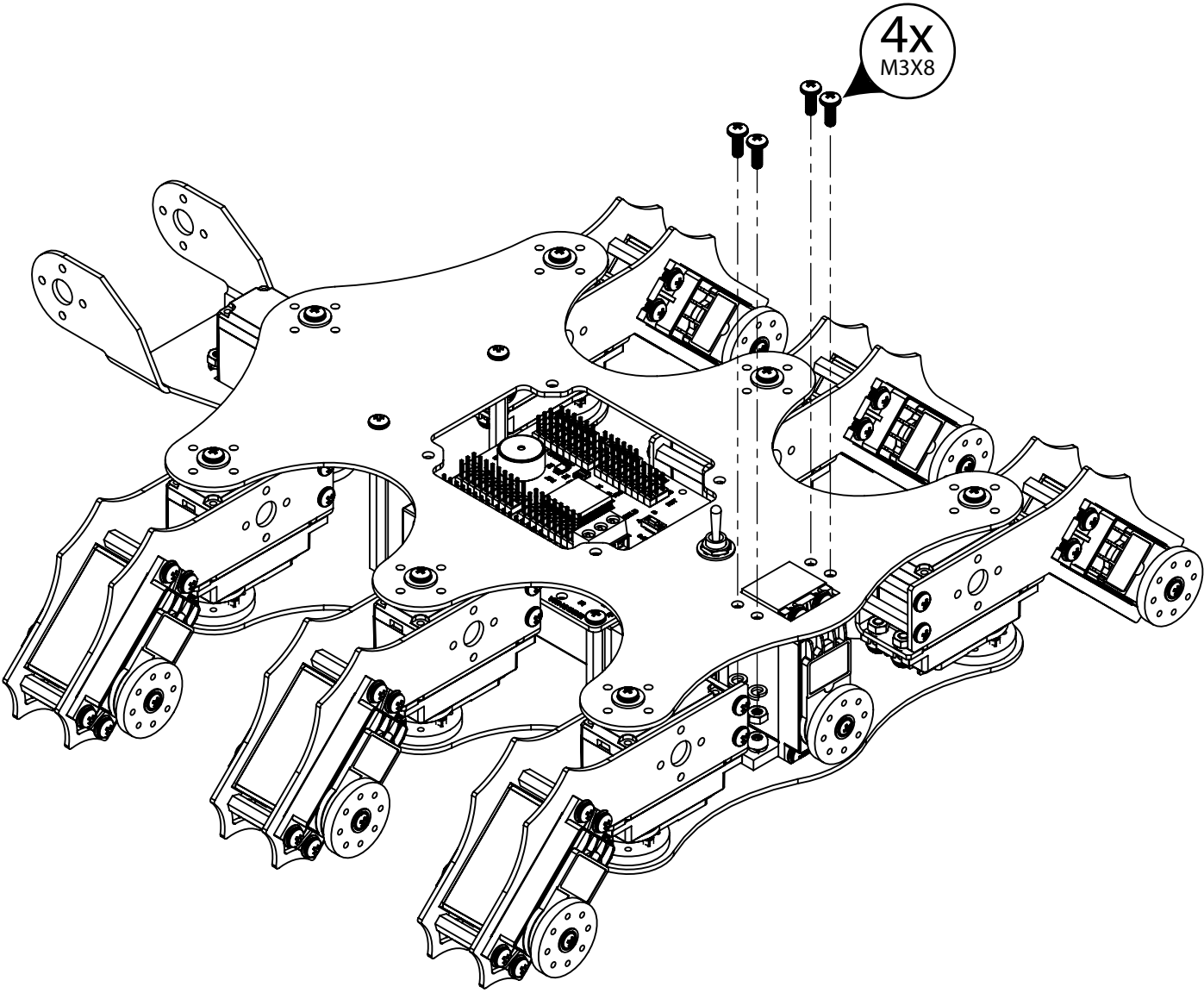

STEP 22

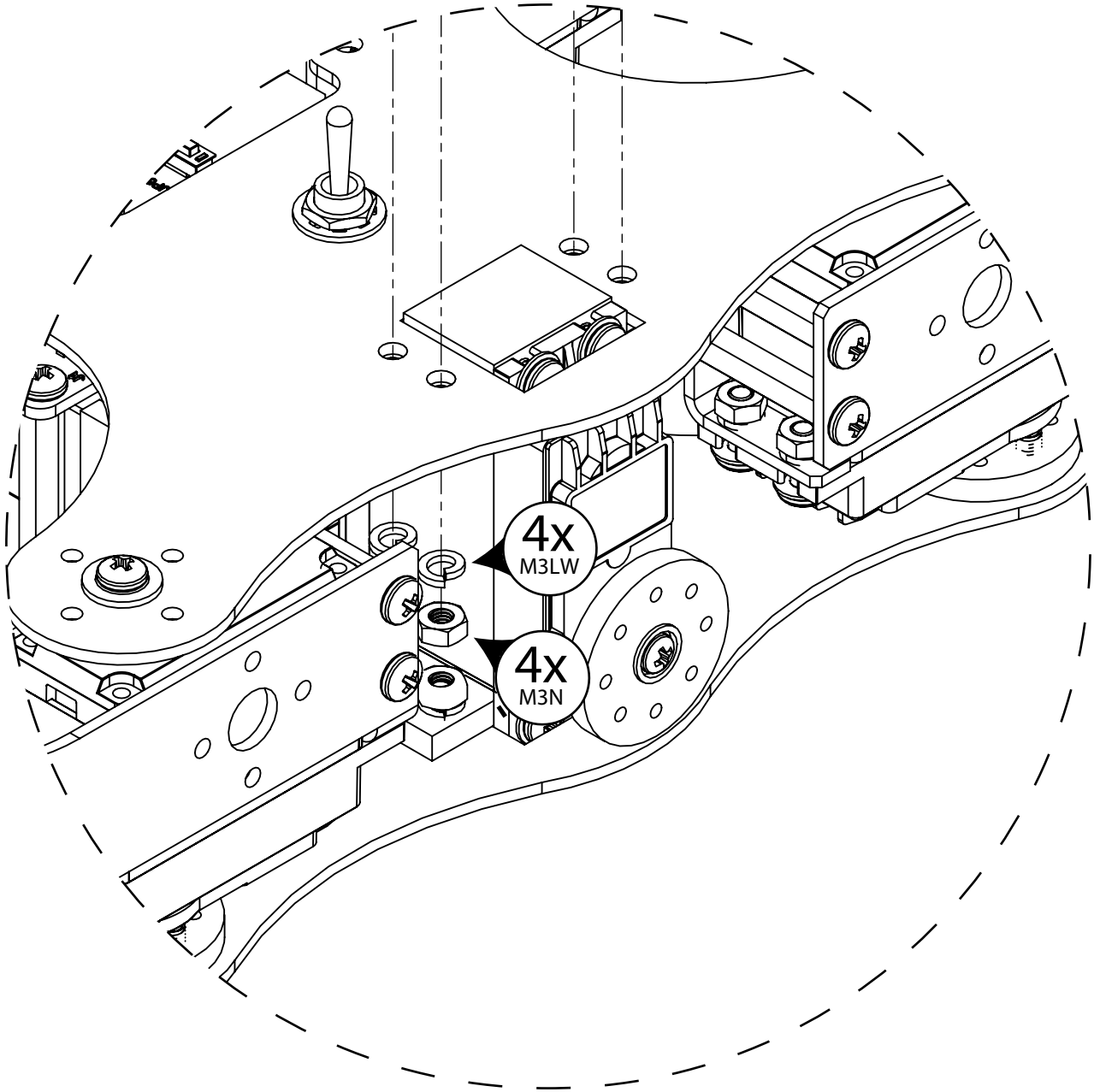

STEP

23

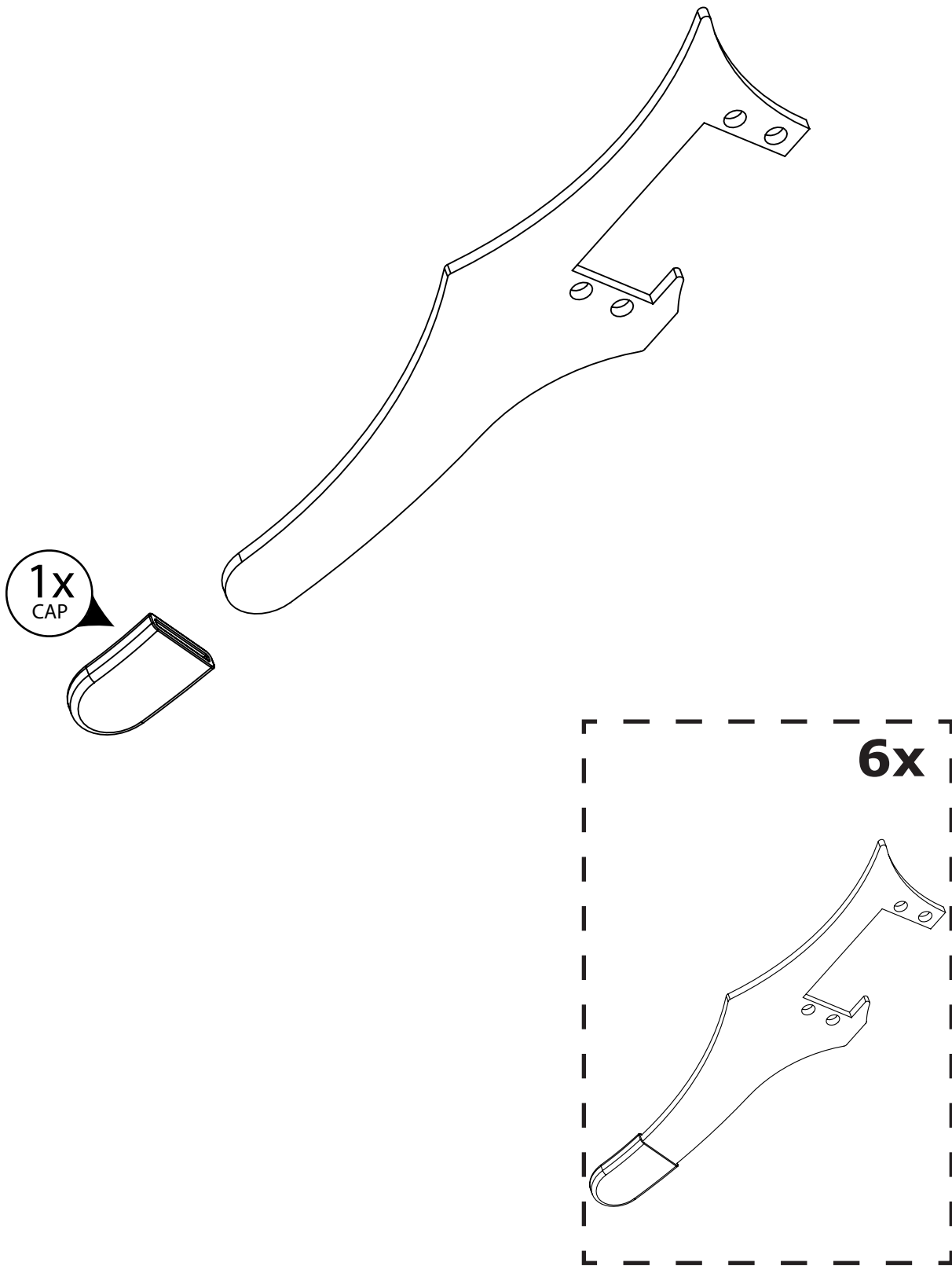

STEP

24

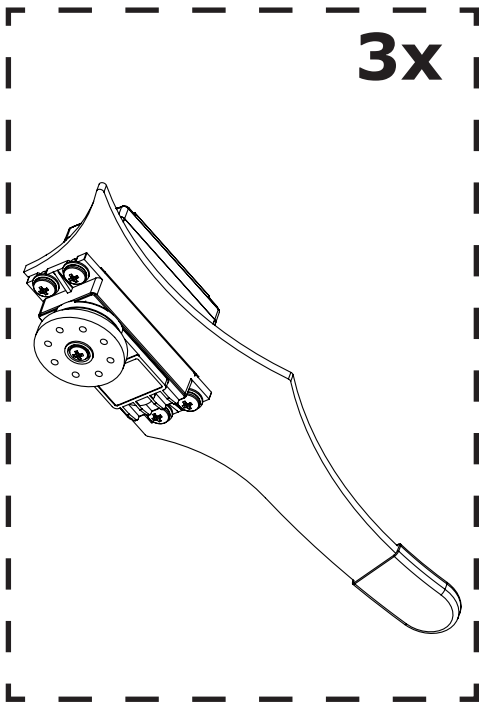
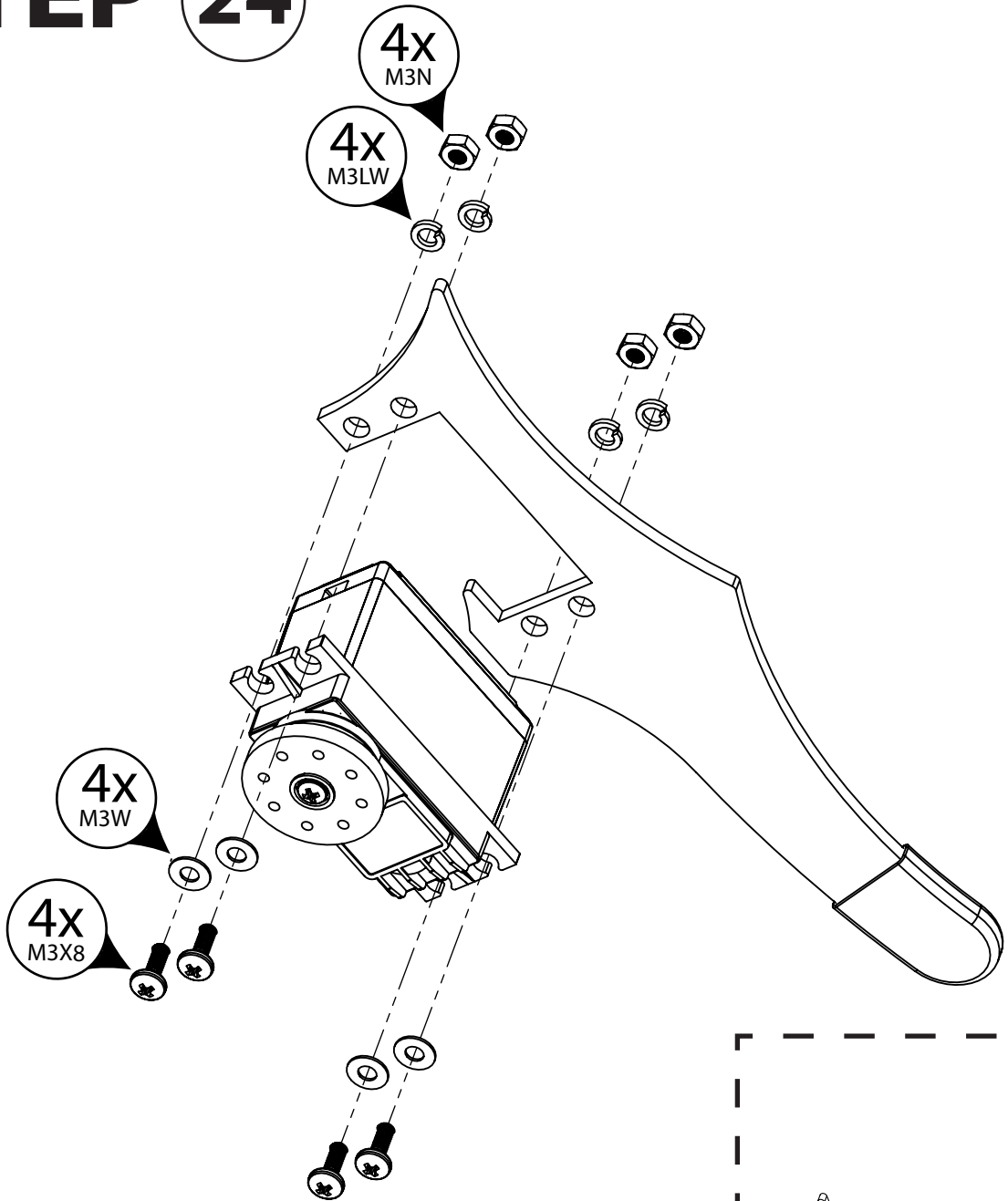

STEP

25

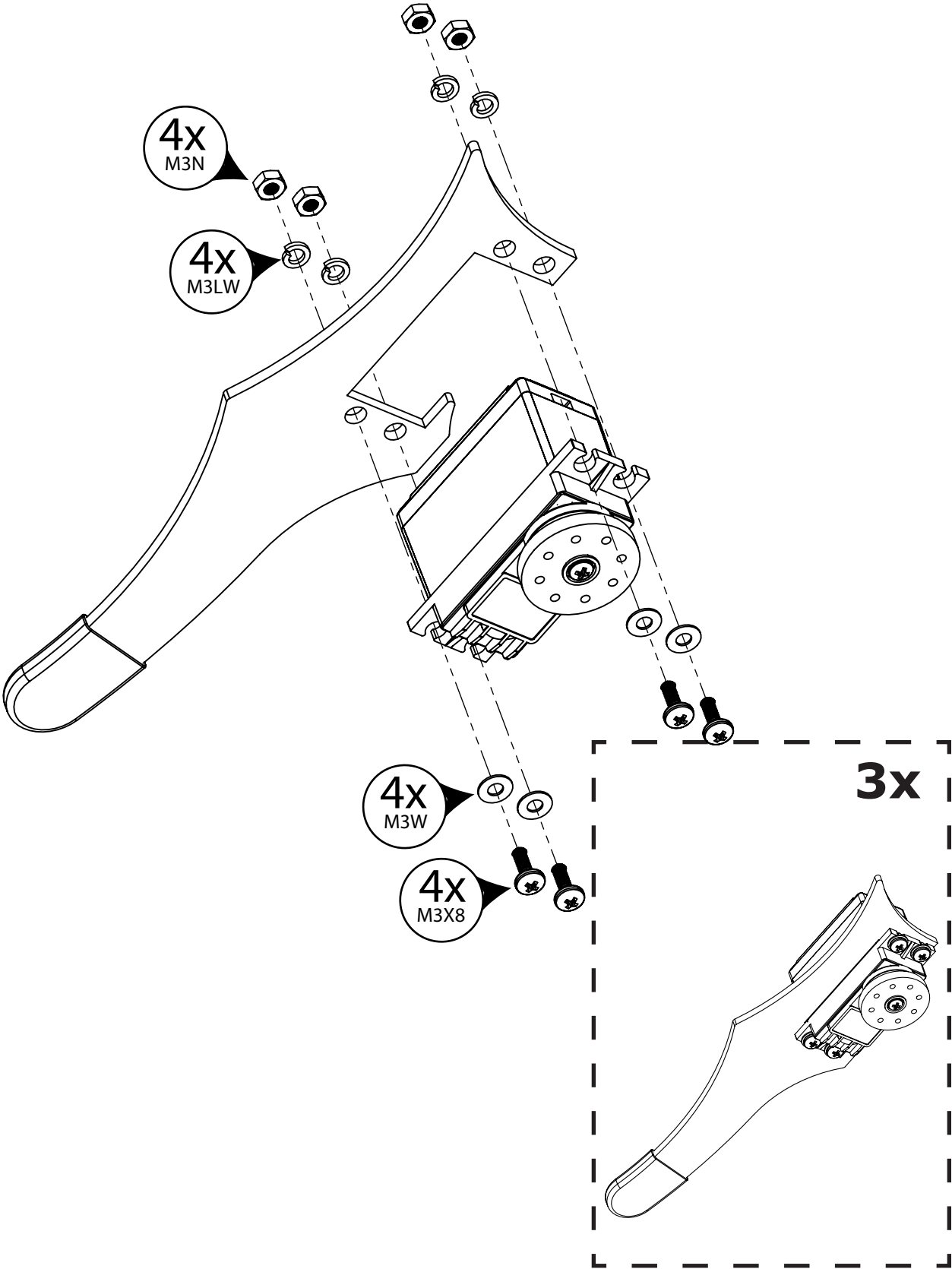

STEP 26

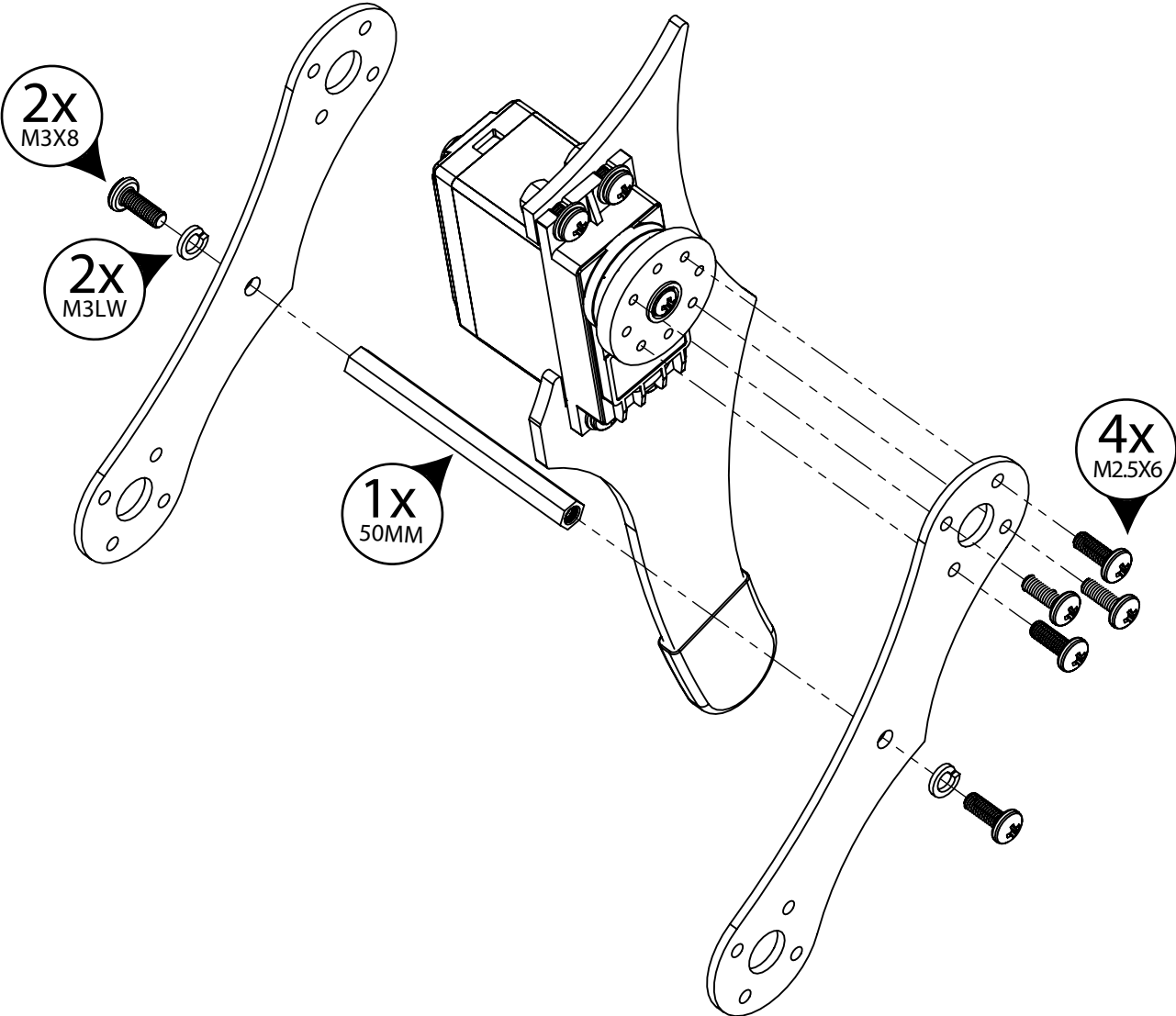

STEP 27

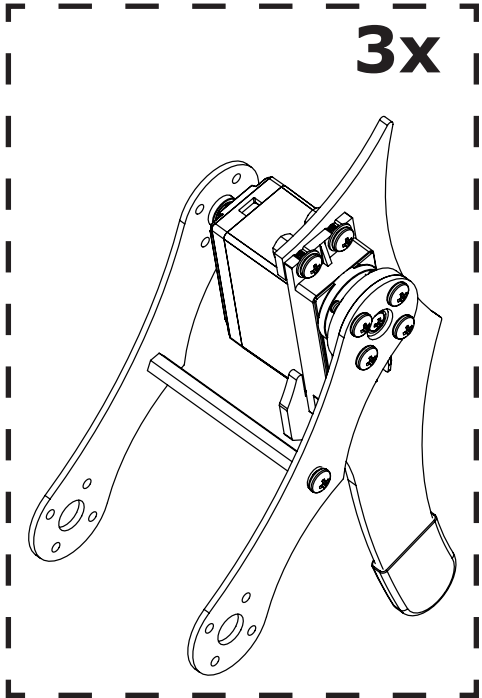
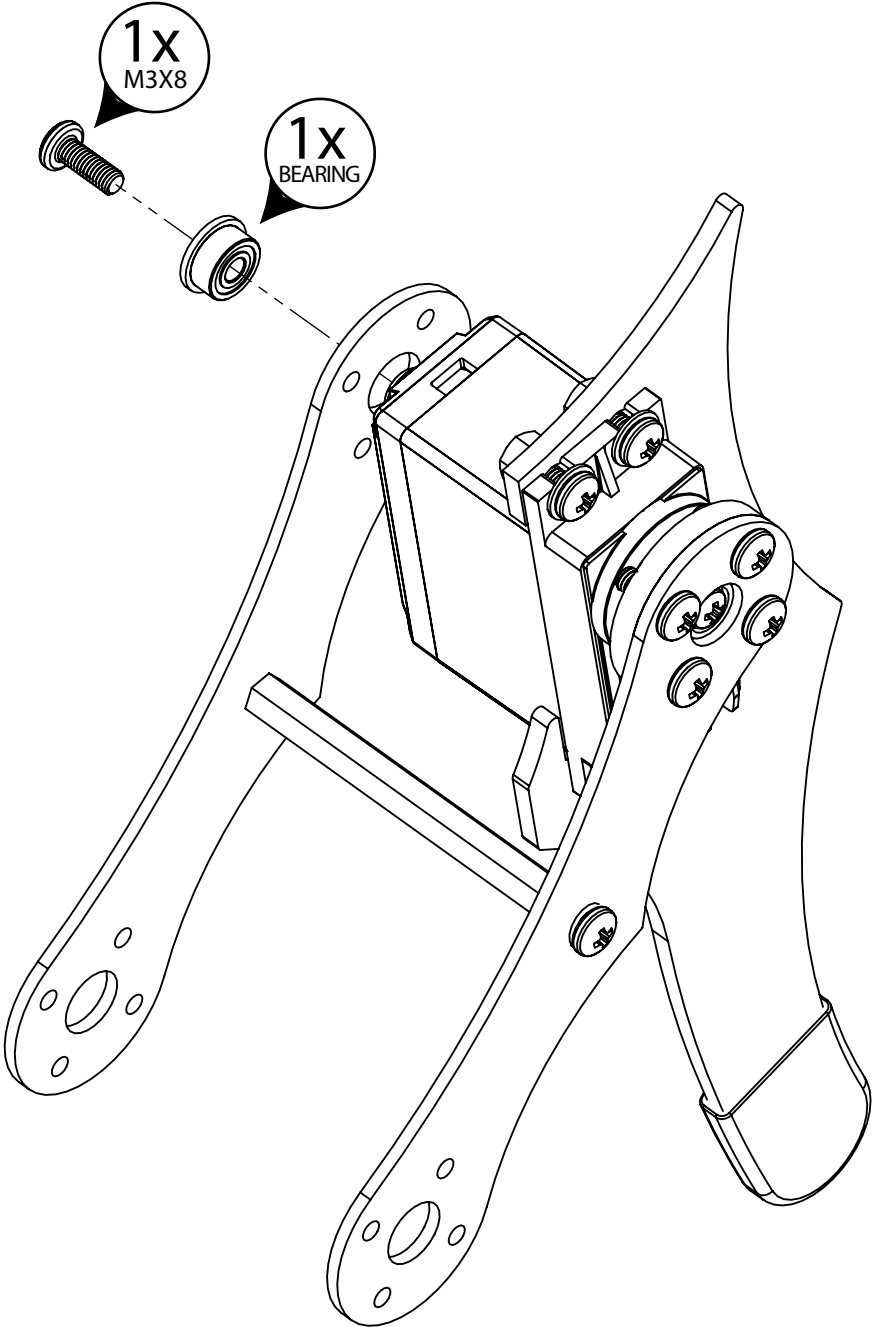

STEP 28

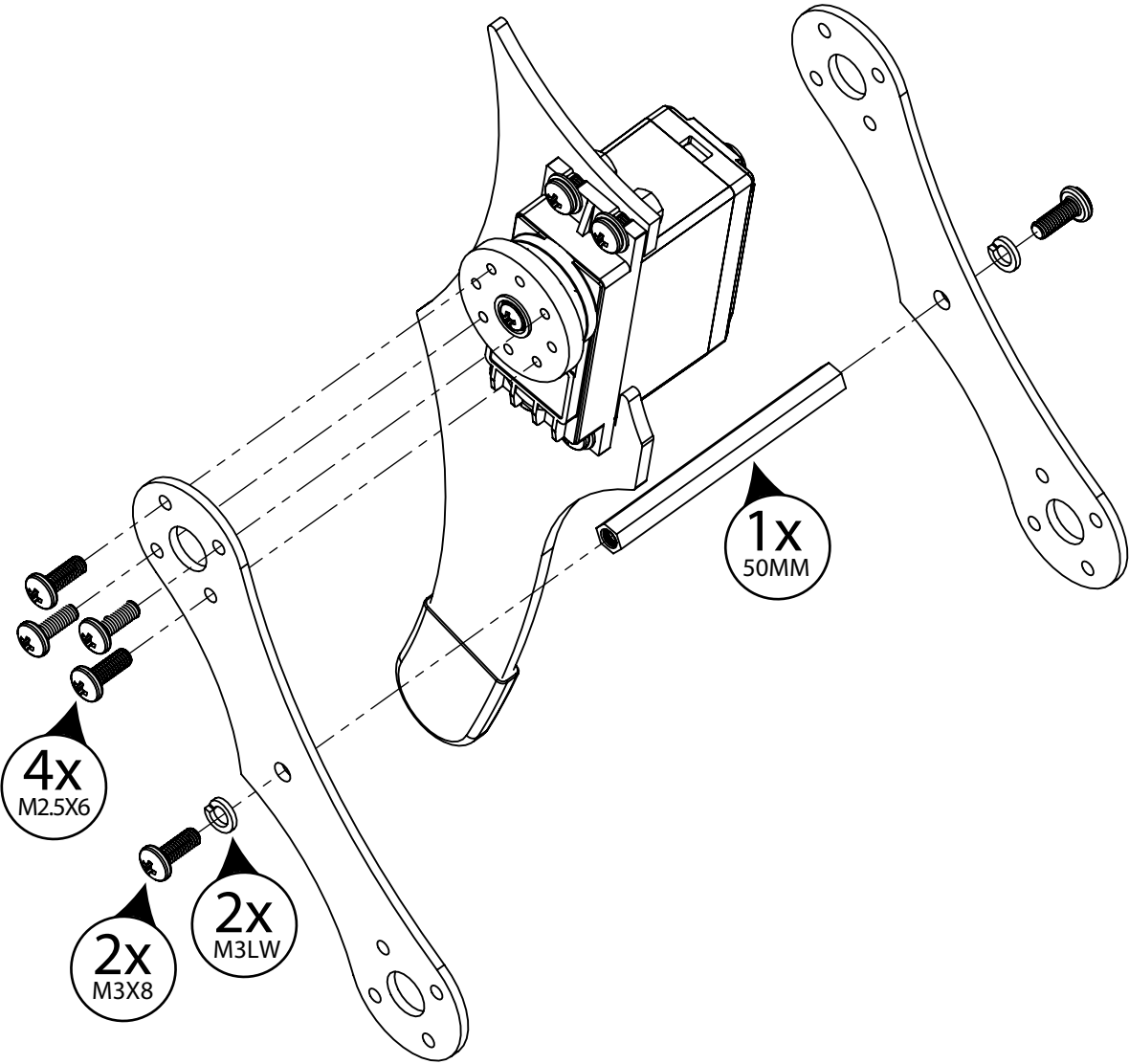

STEP

29

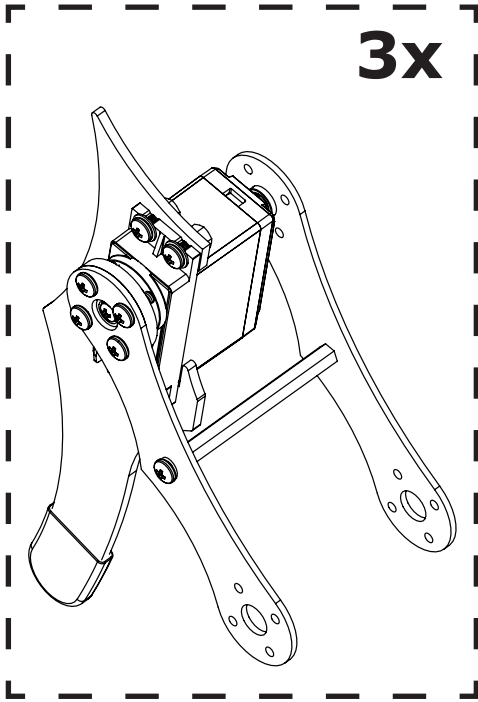
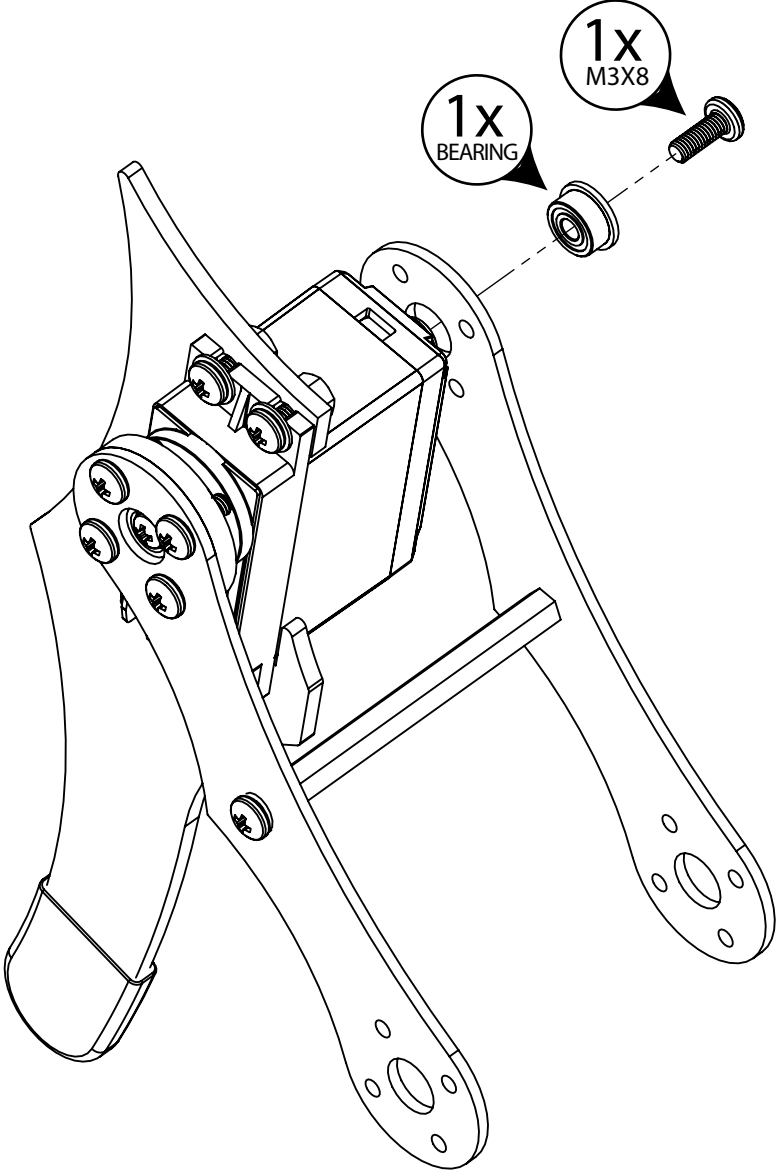

STEP

30

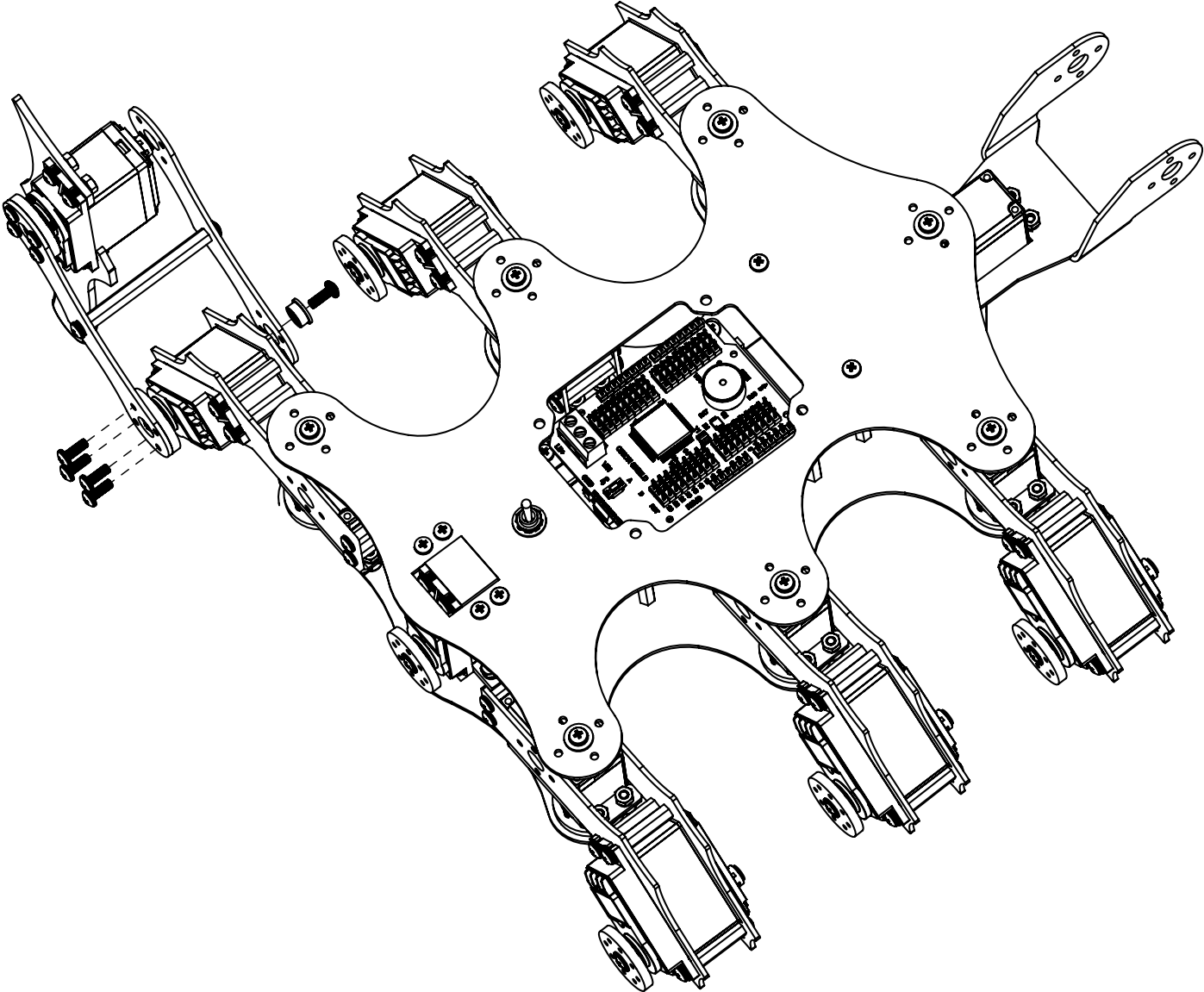

STEP

31

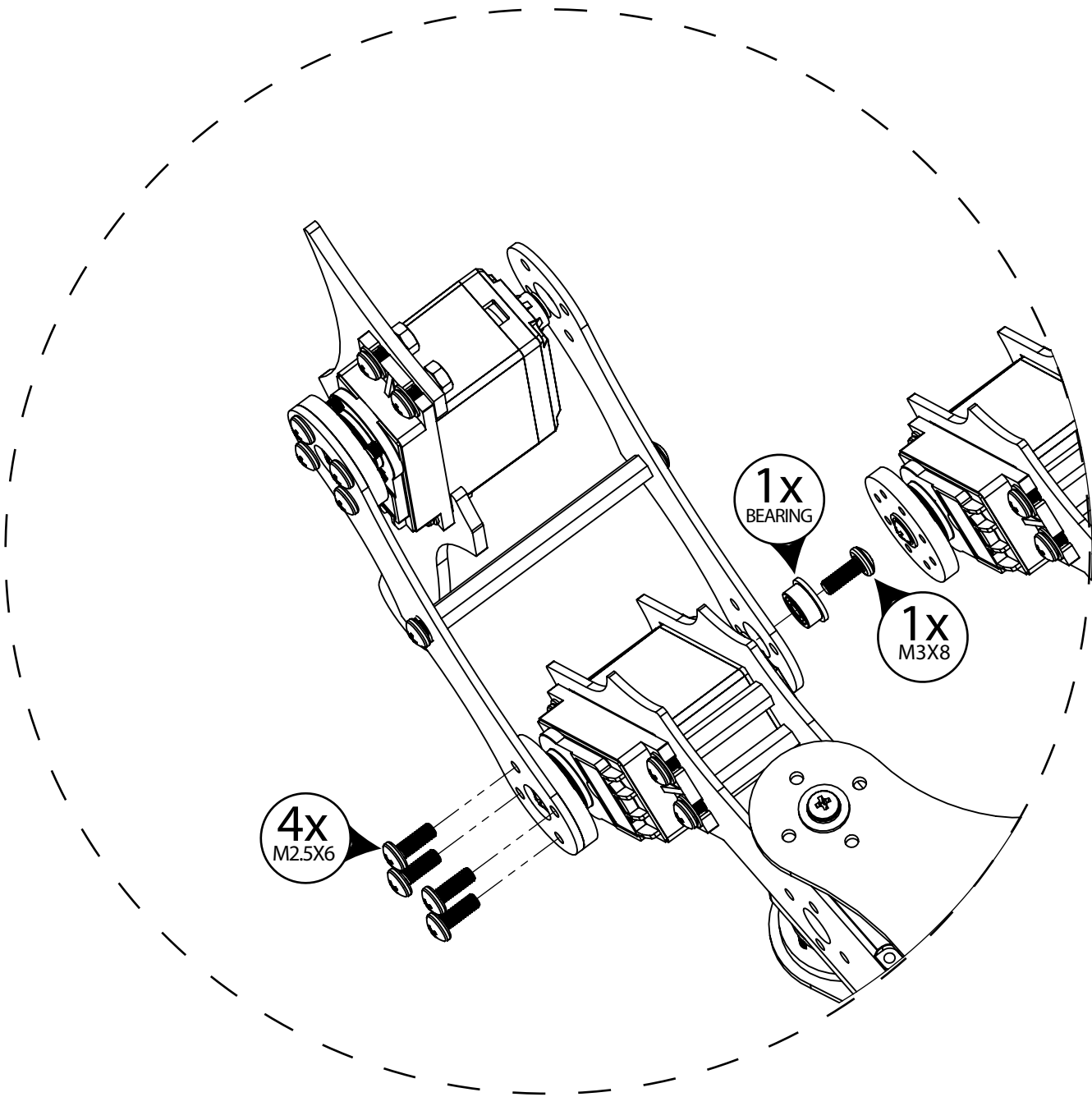

STEP 32

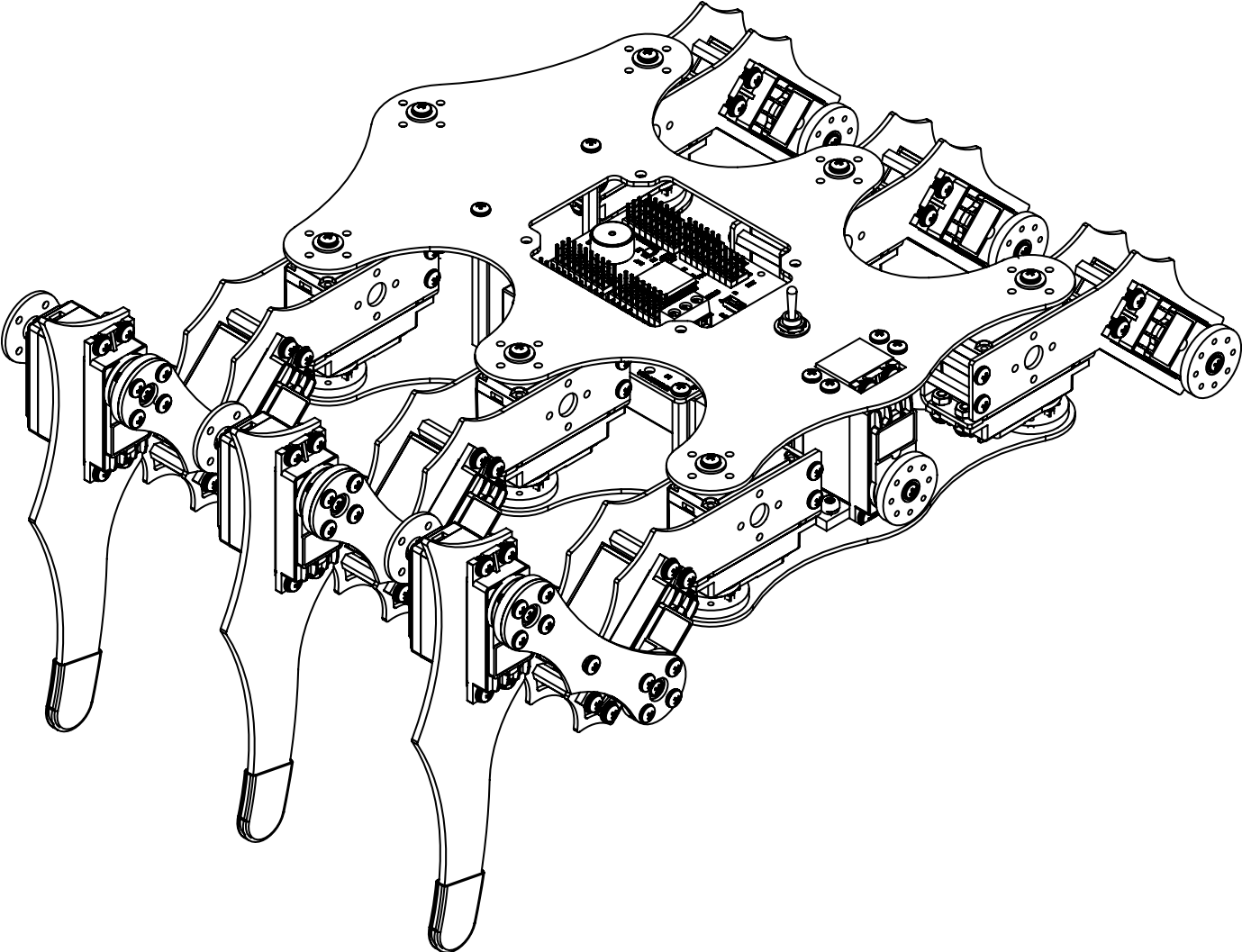

STEP

33

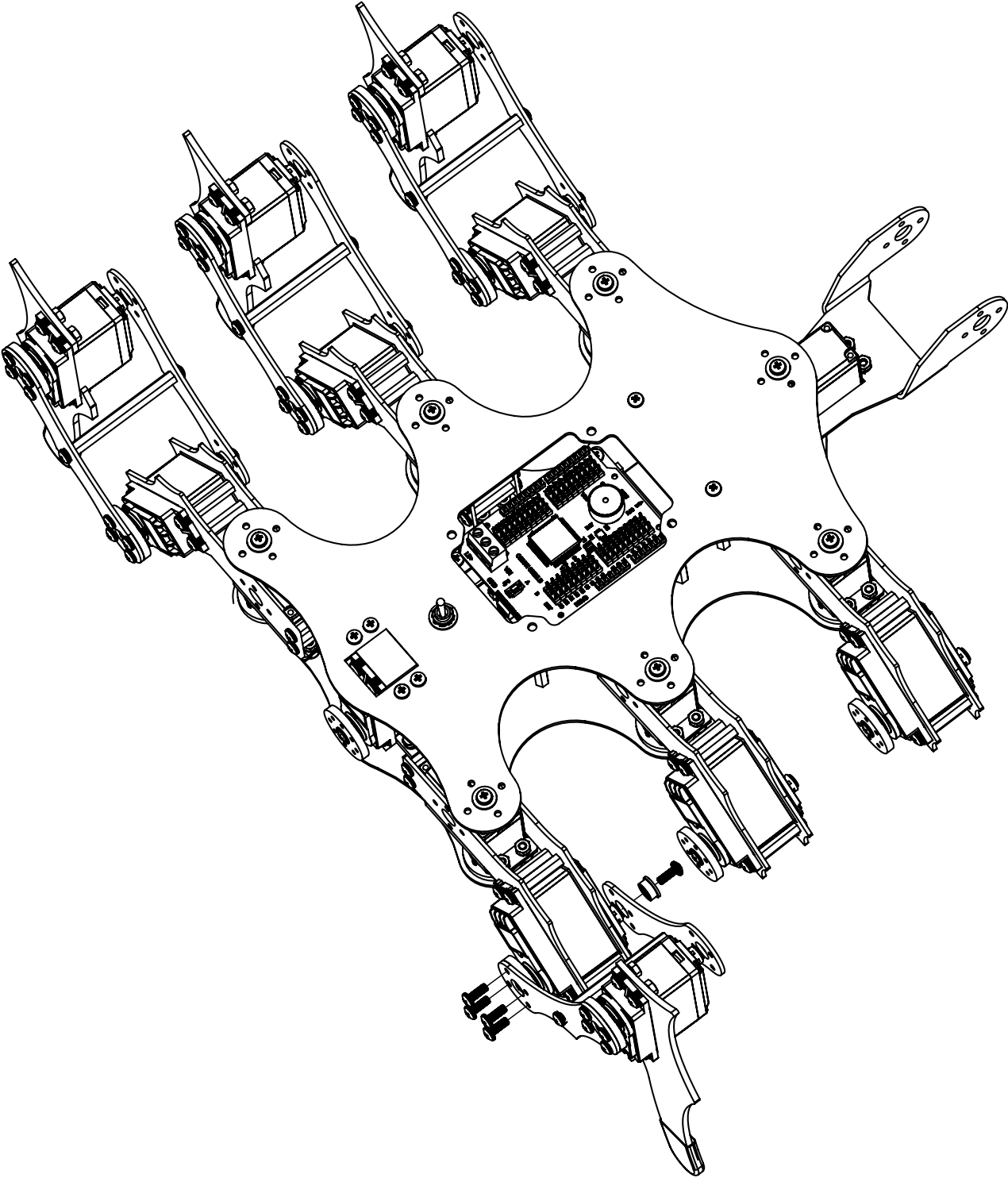

STEP

34

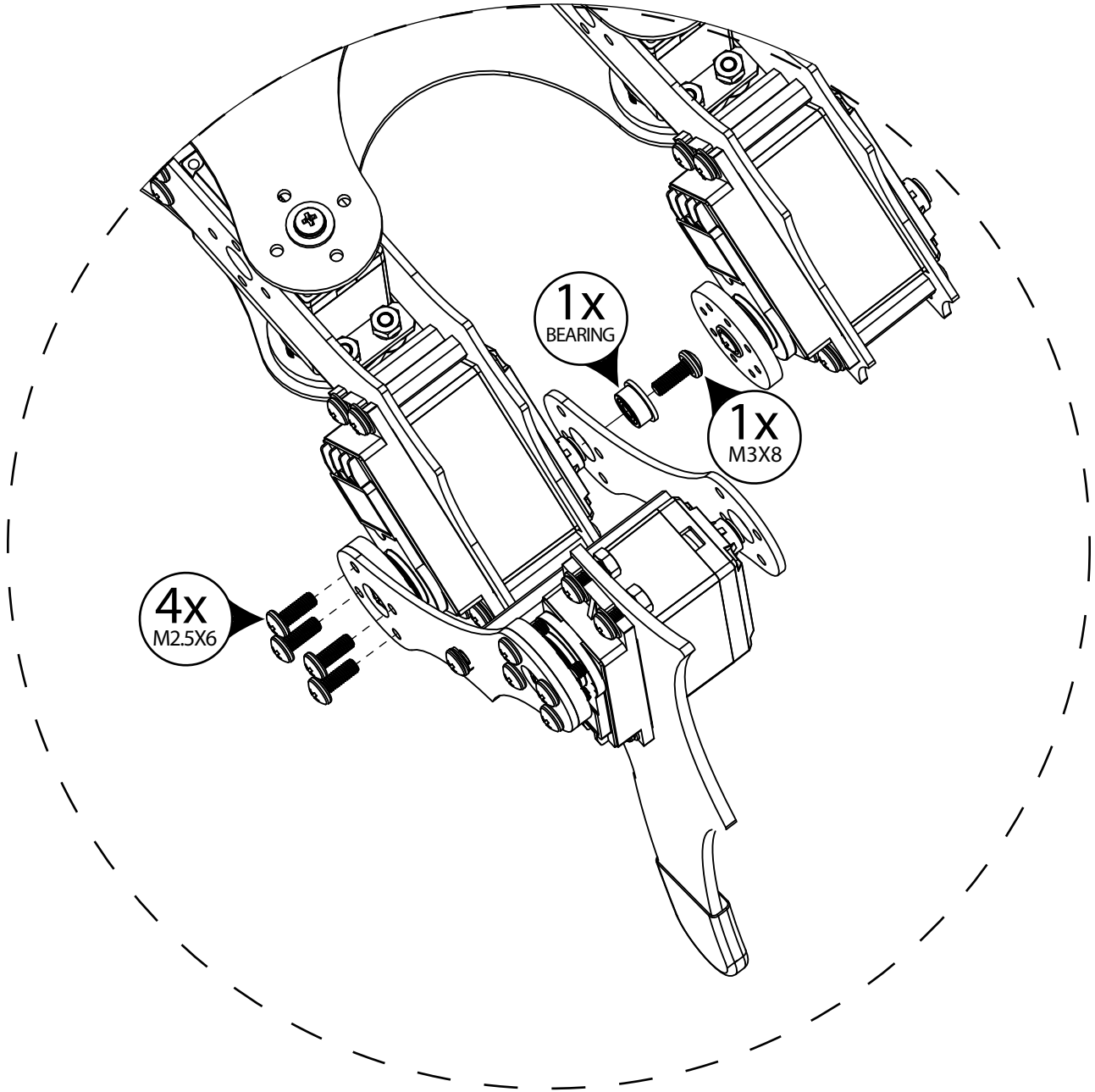

STEP

35

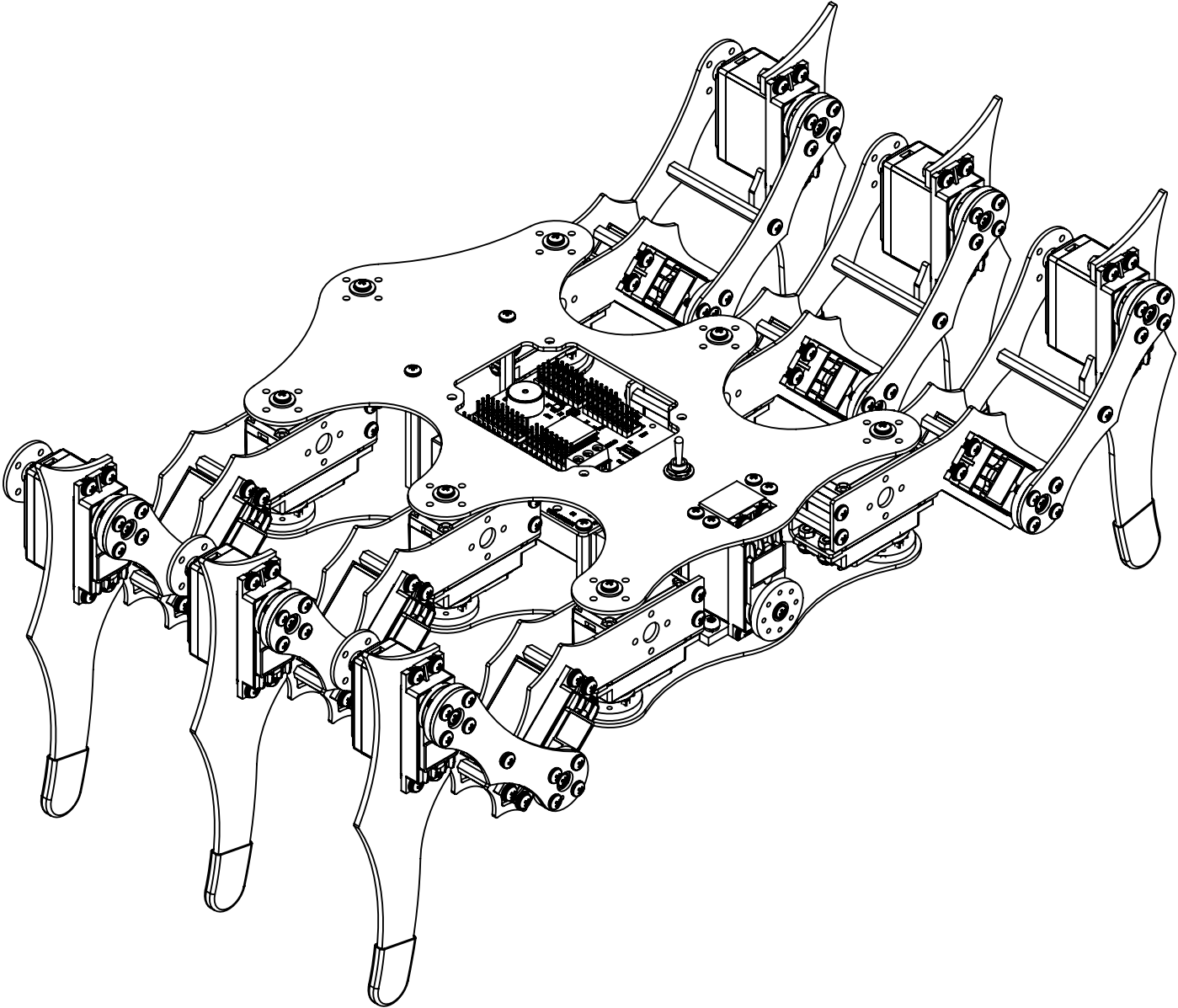

STEP

36

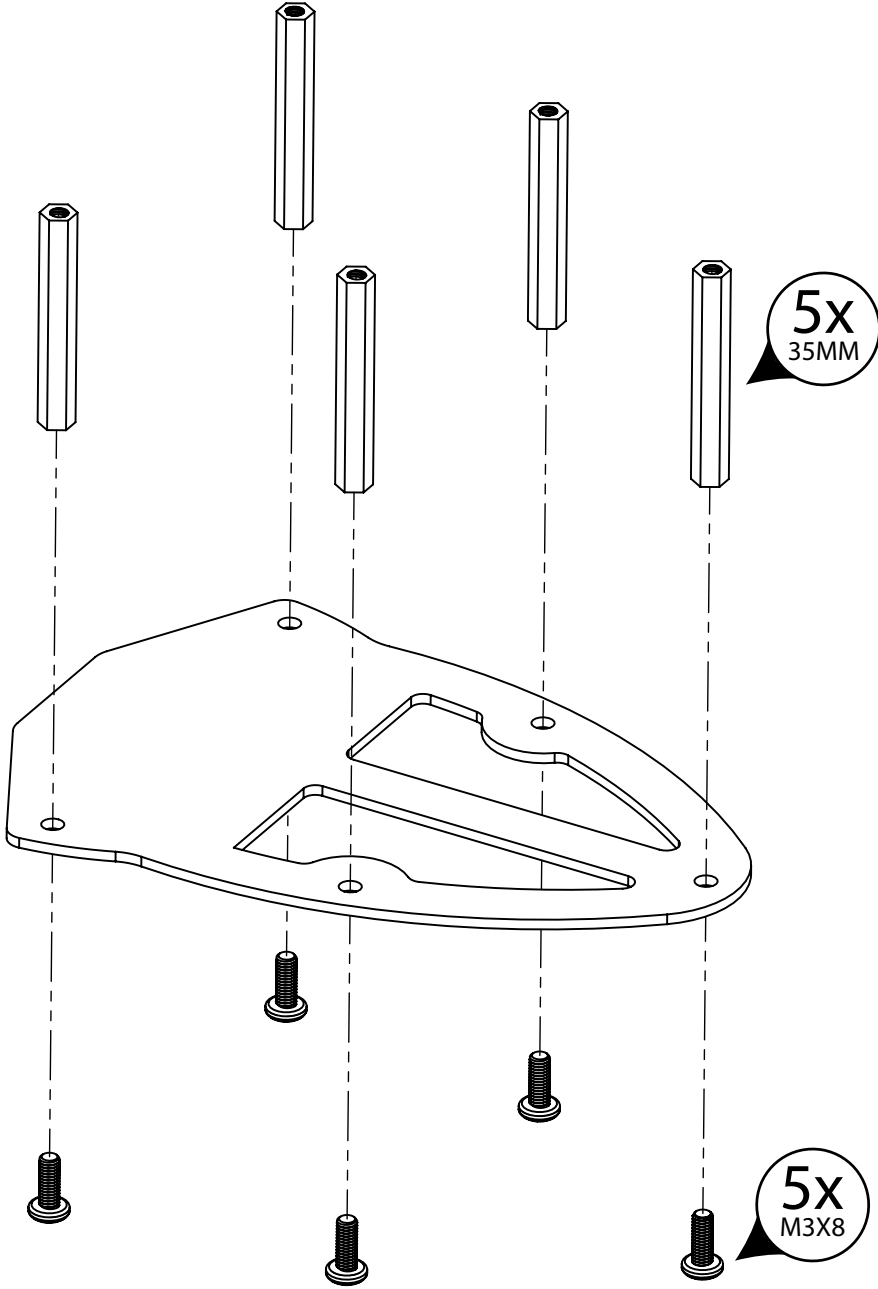

STEP

37

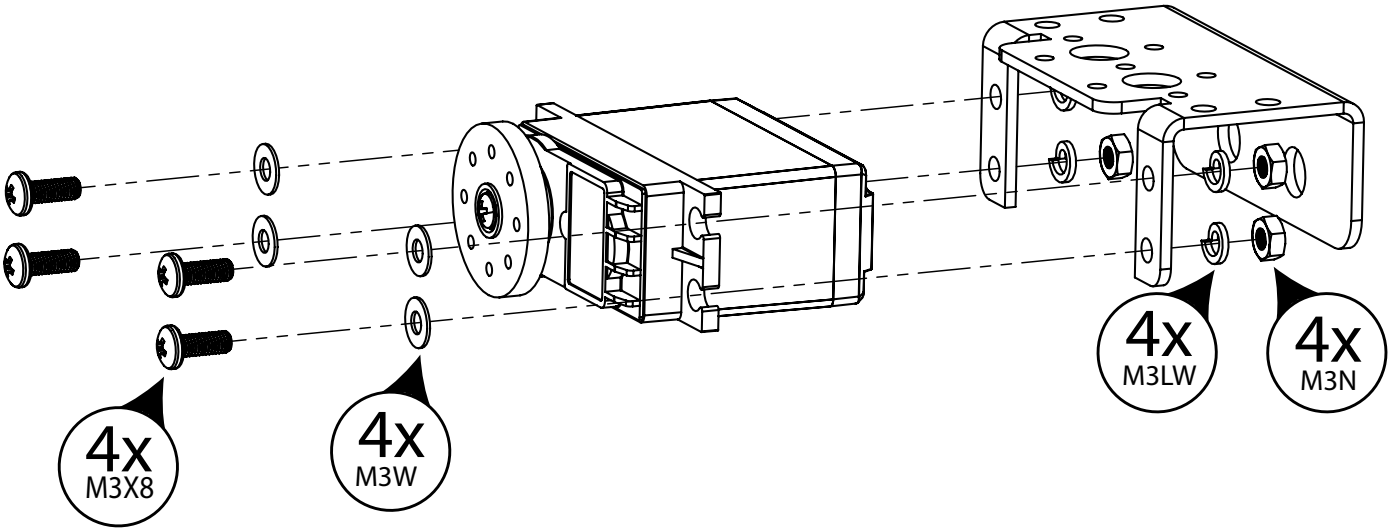

STEP

38

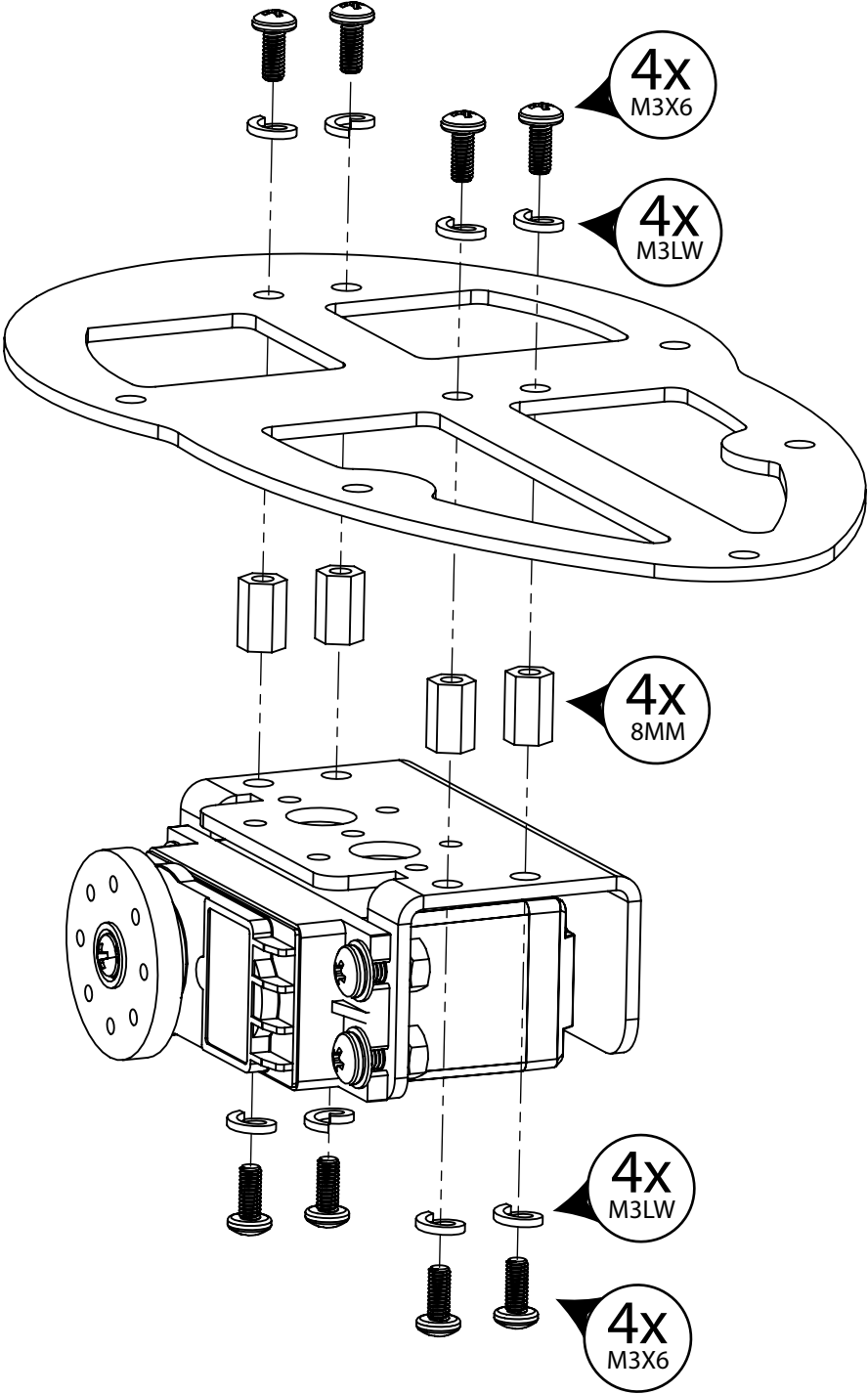

STEP

39

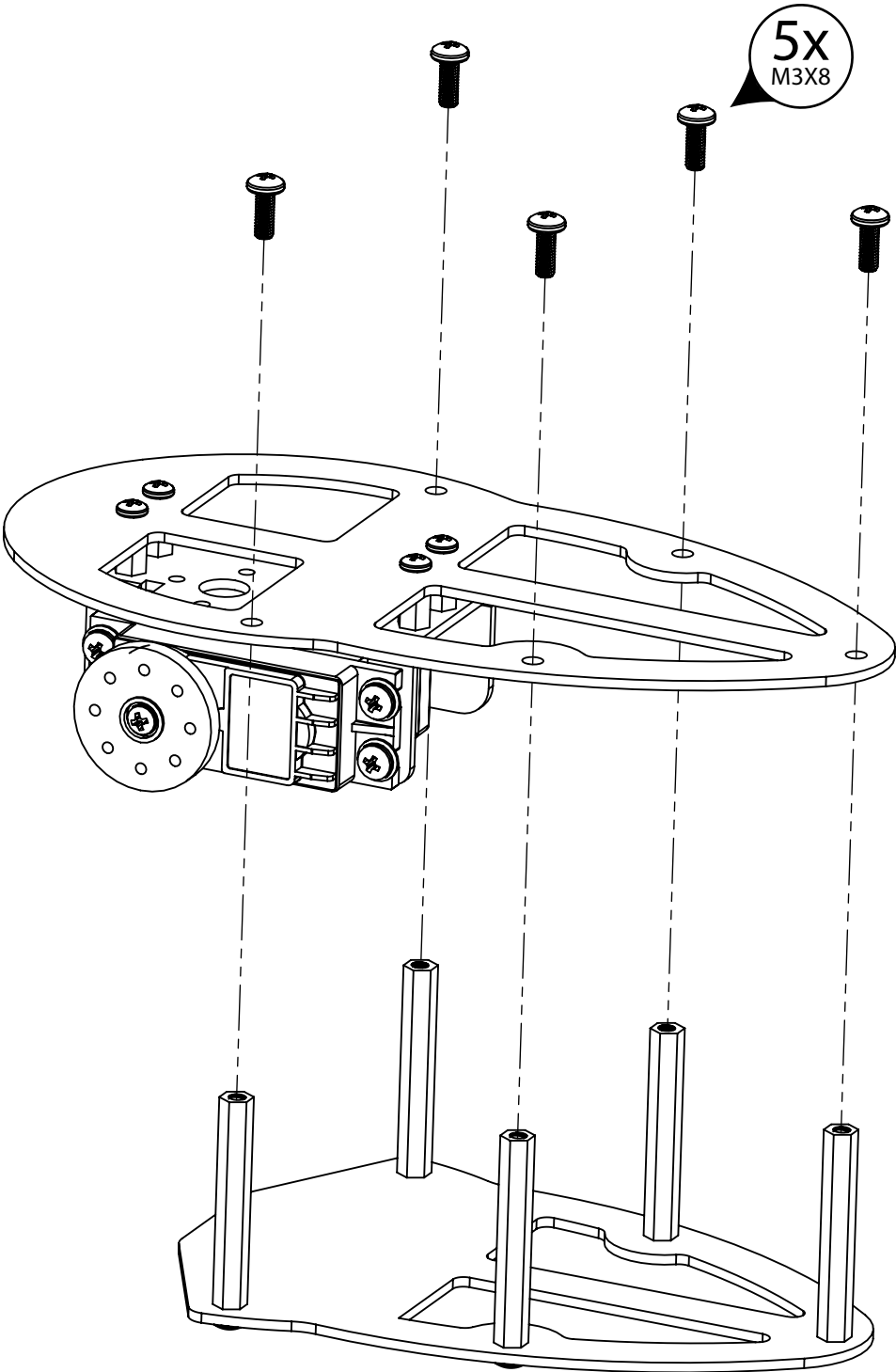

STEP

40

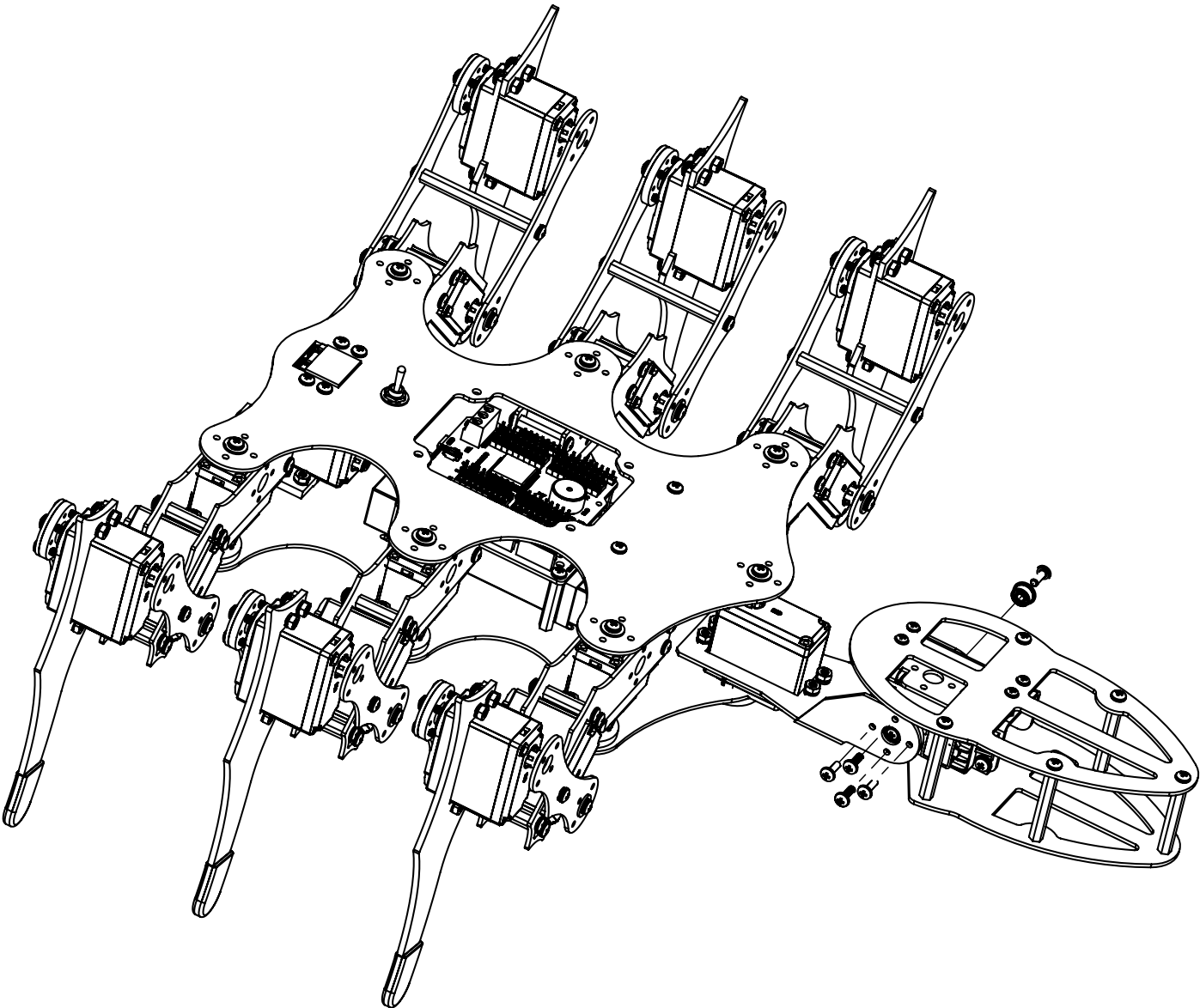

STEP

41

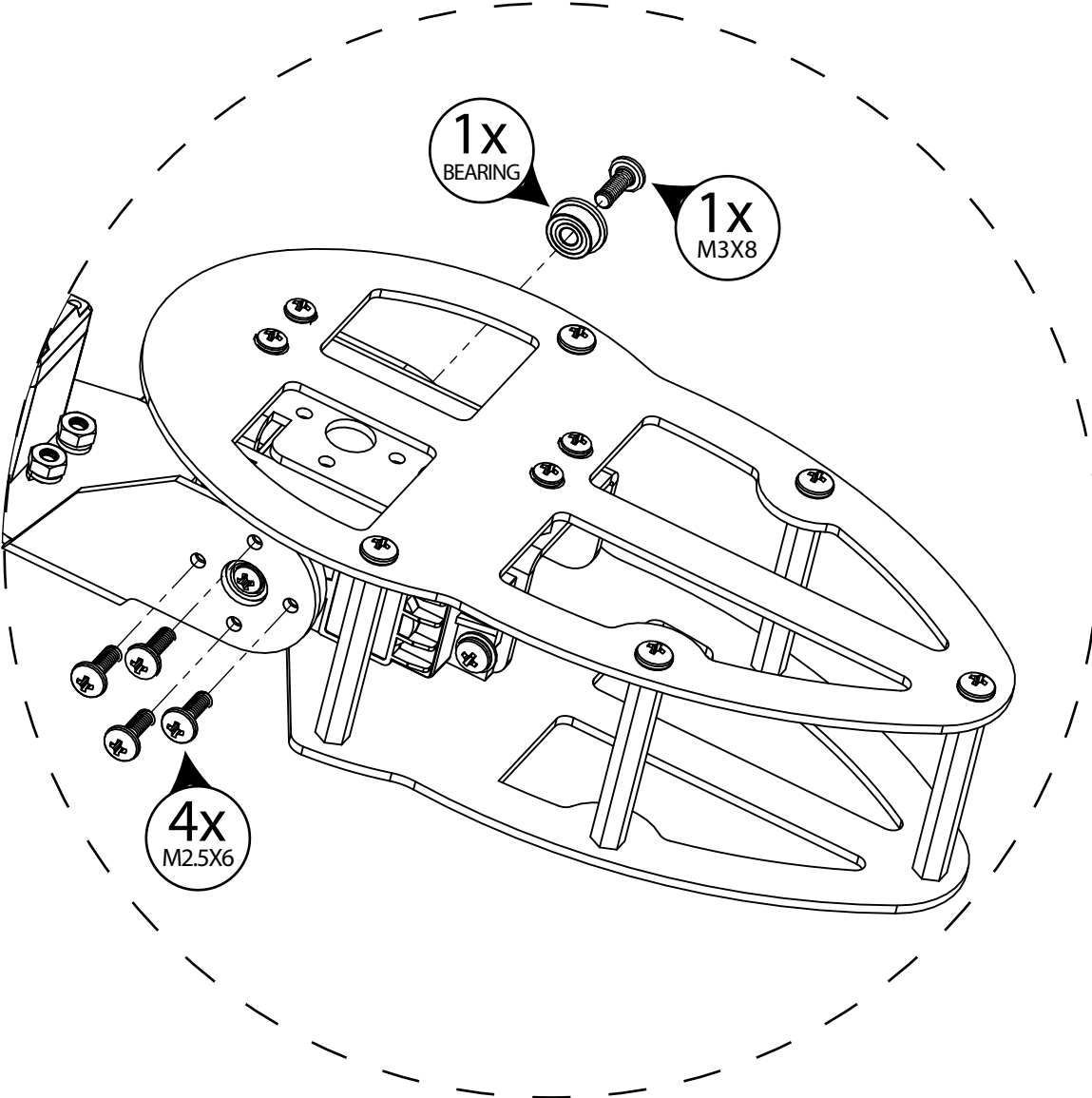

STEP

42

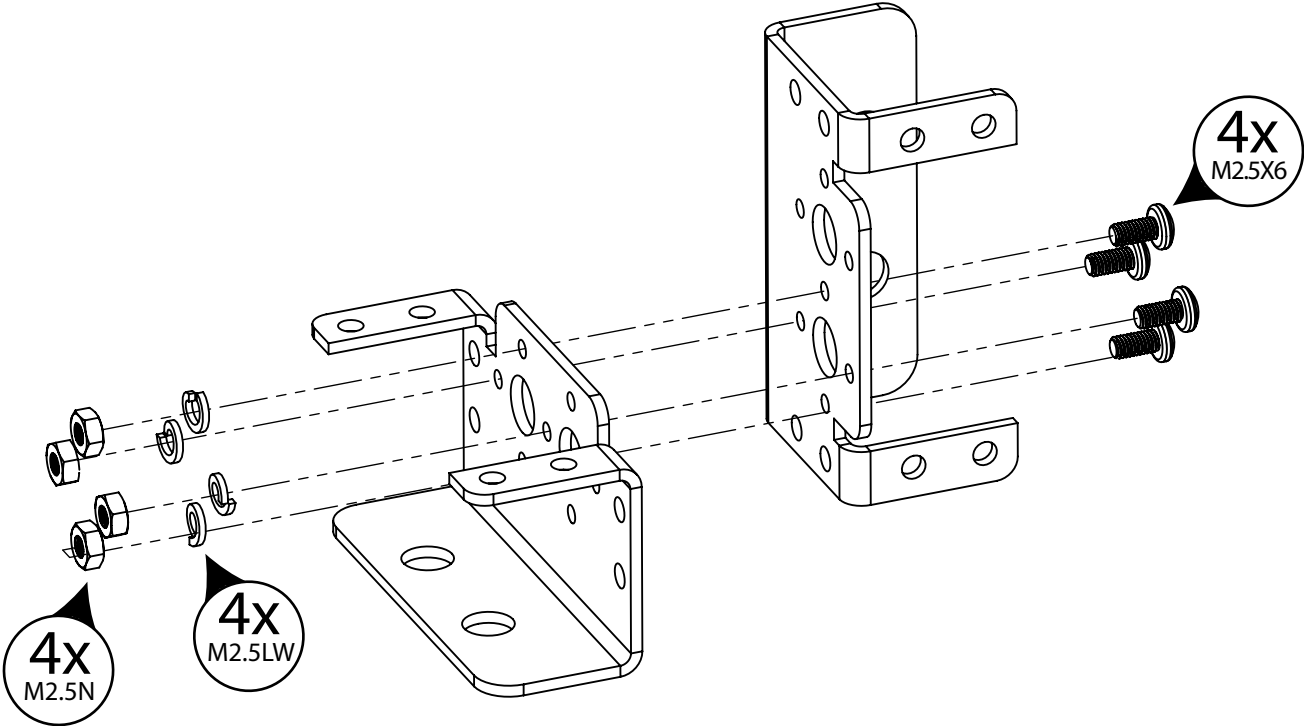

STEP

43

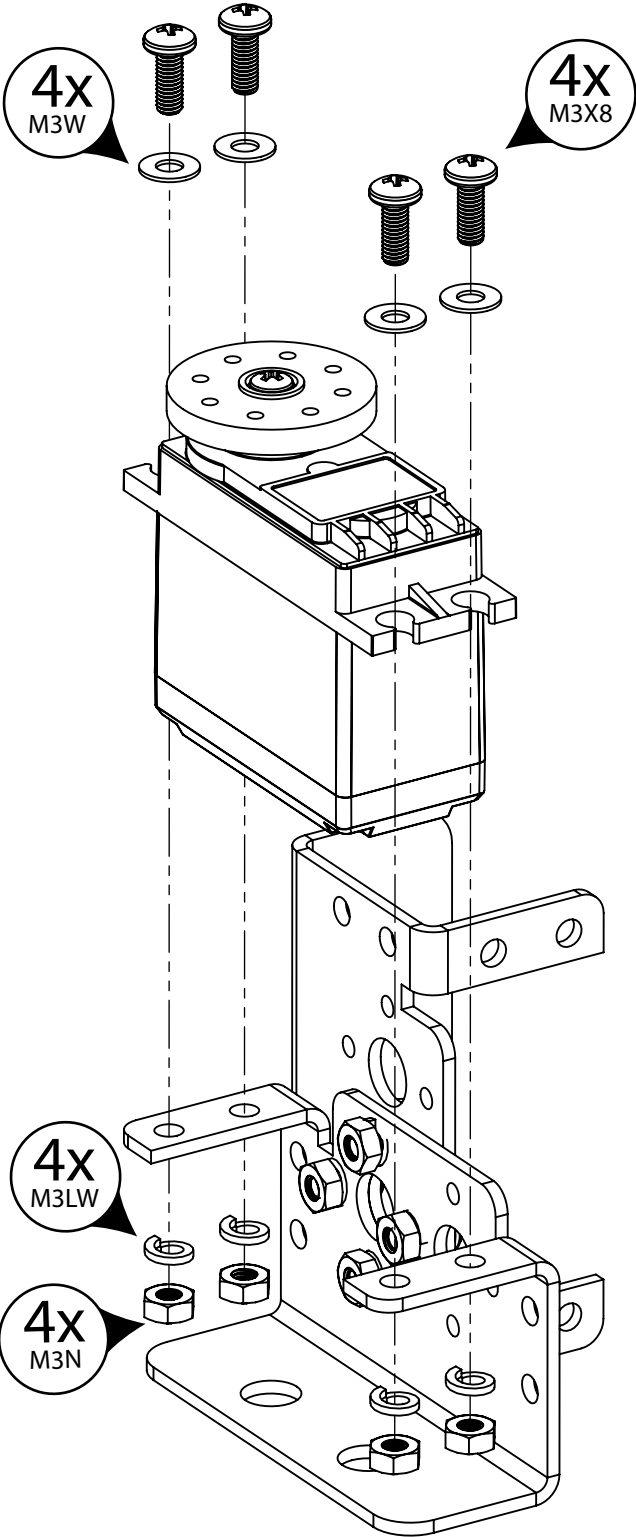

STEP

44

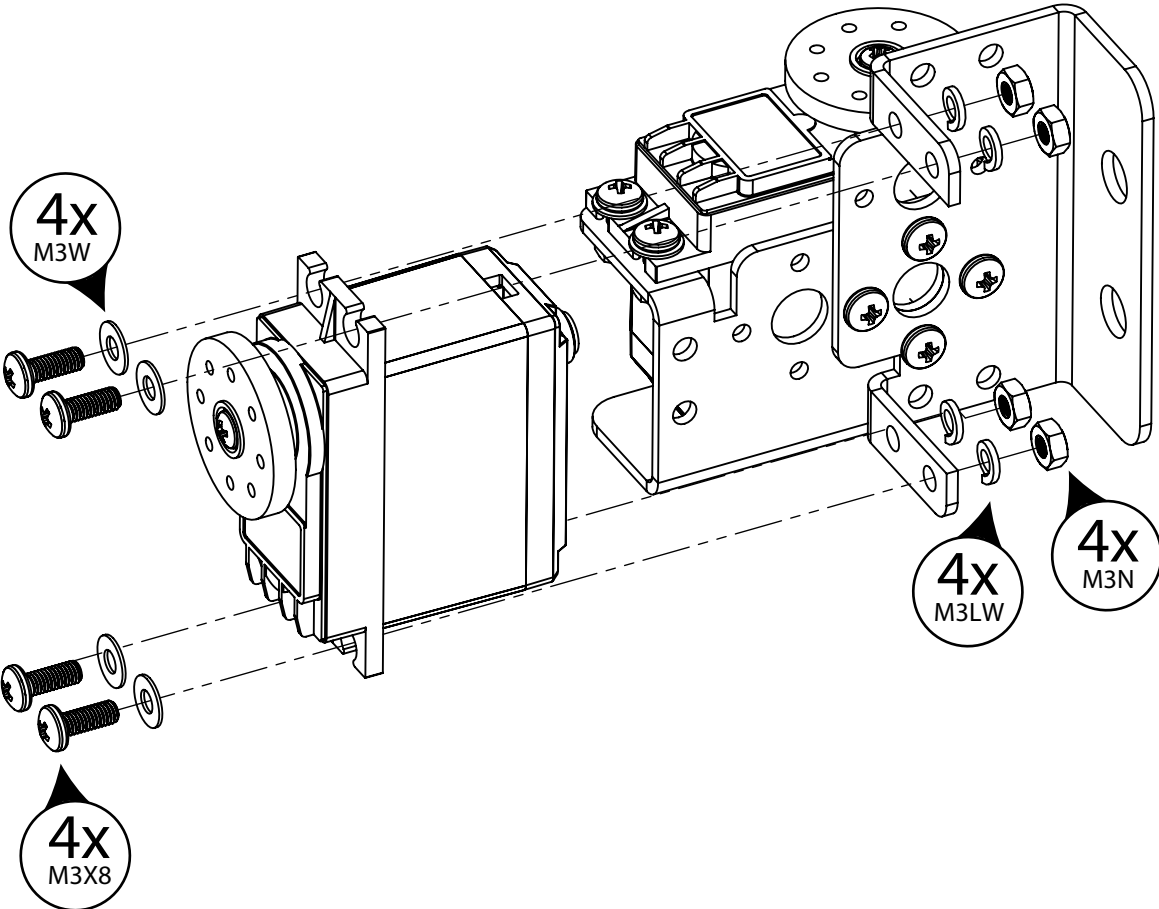

STEP

45

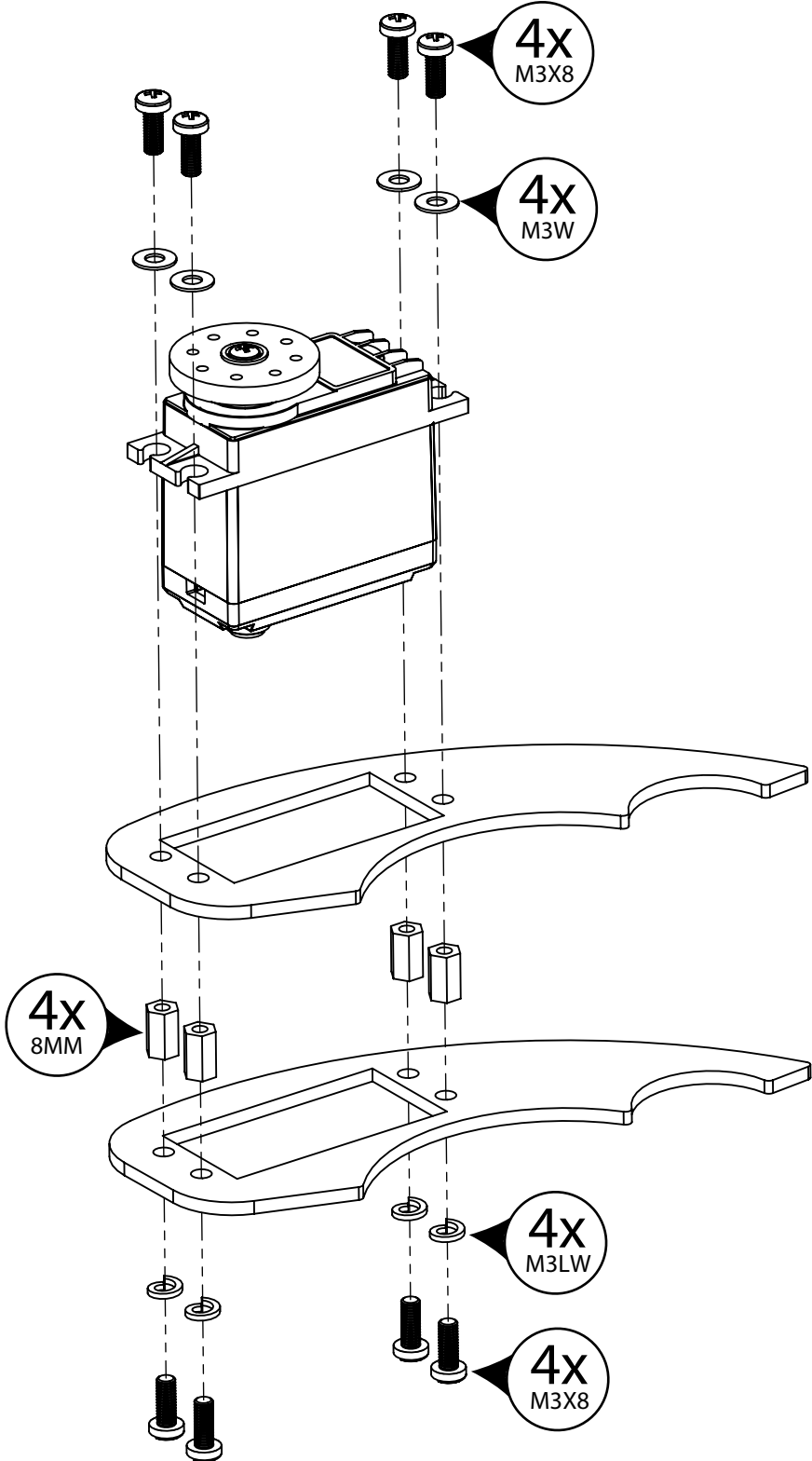

STEP

46

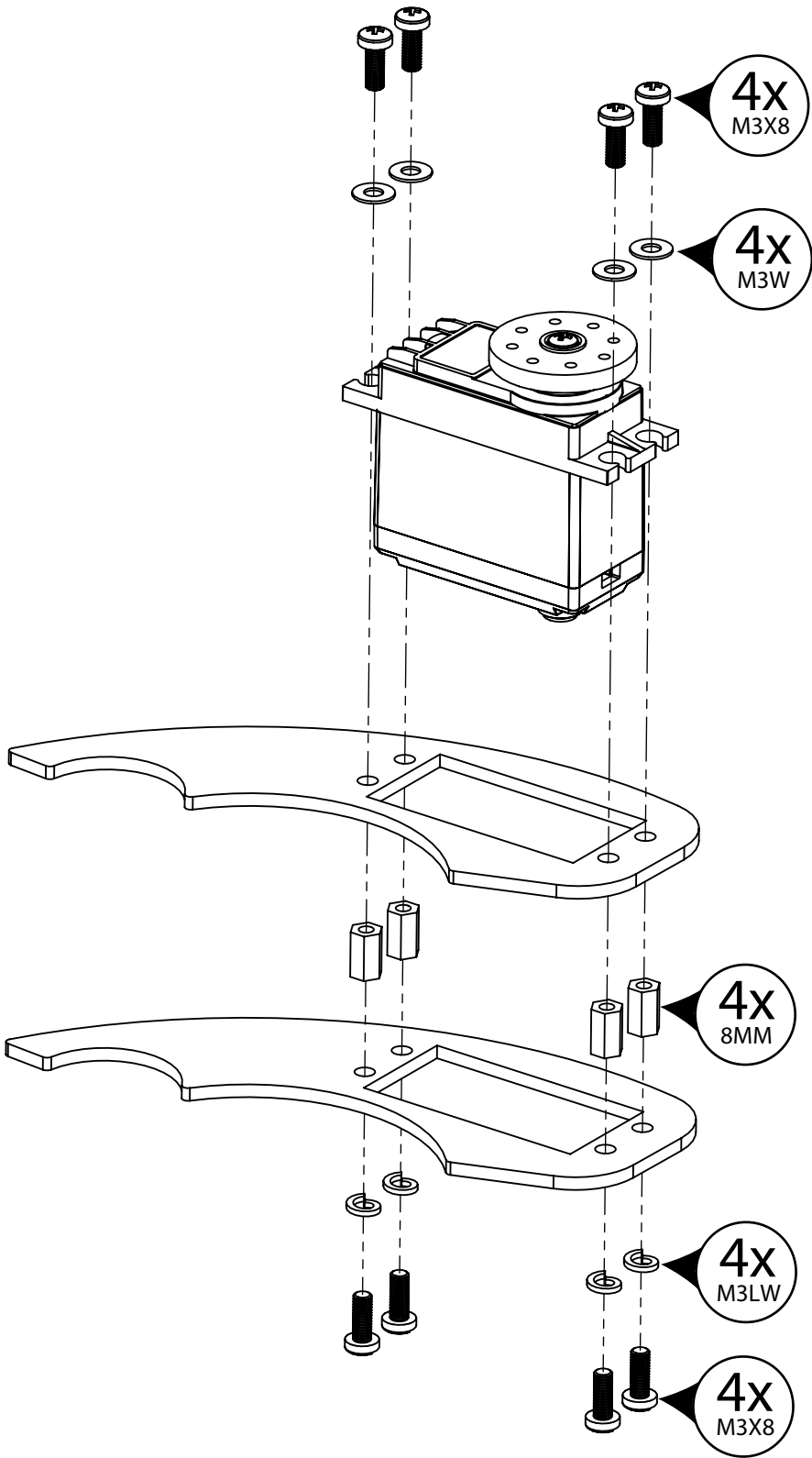

STEP

47

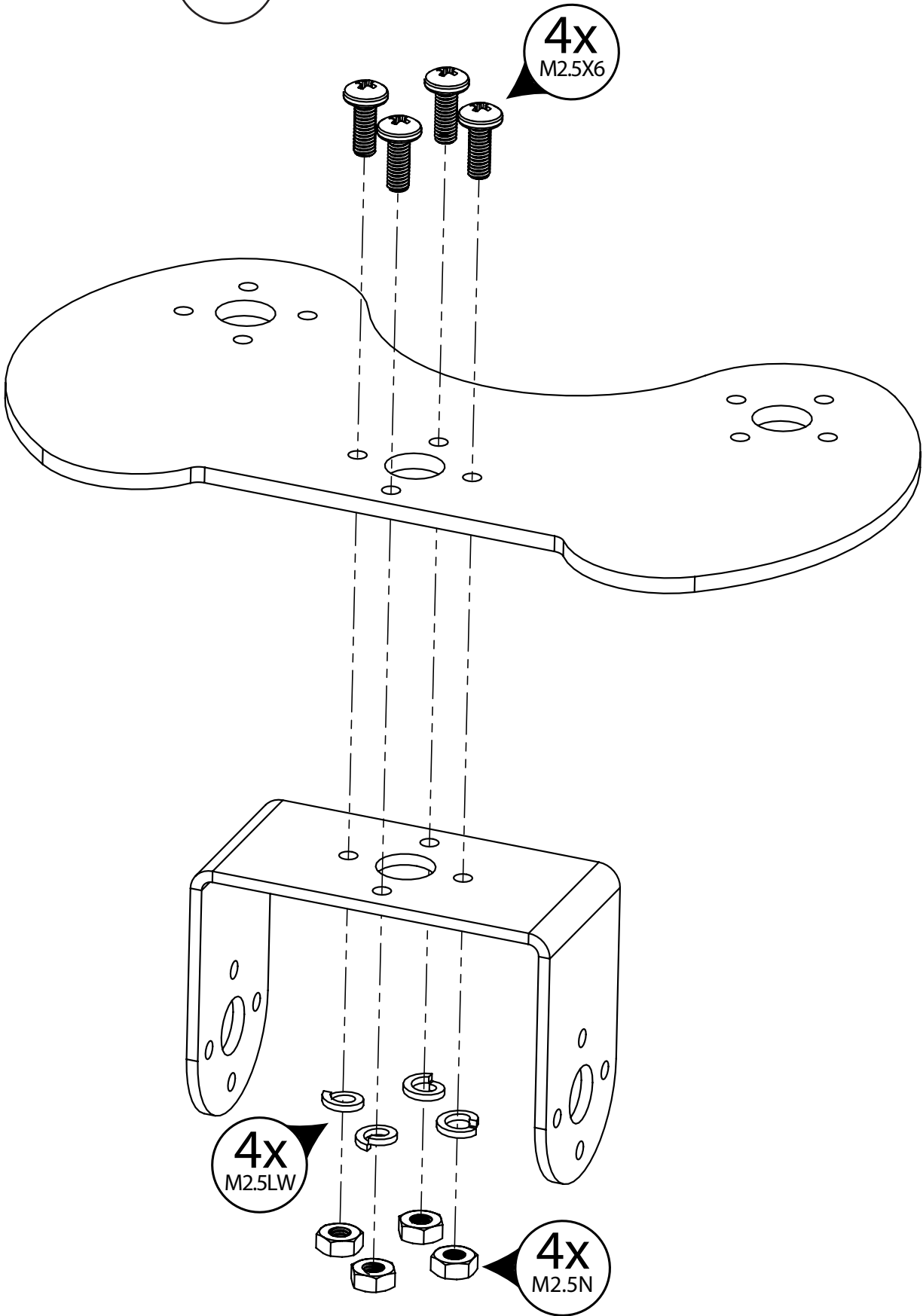

STEP

48

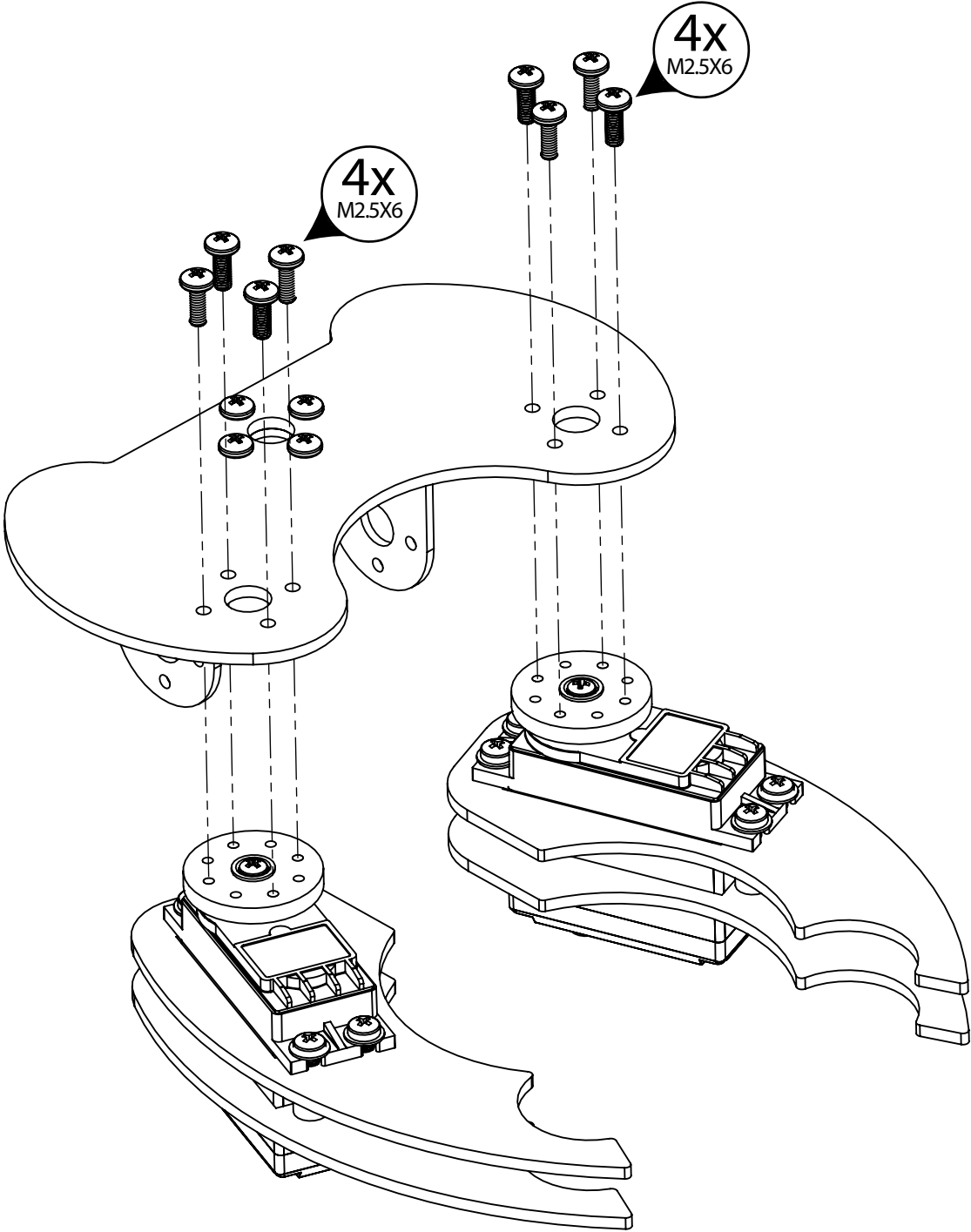

STEP

49

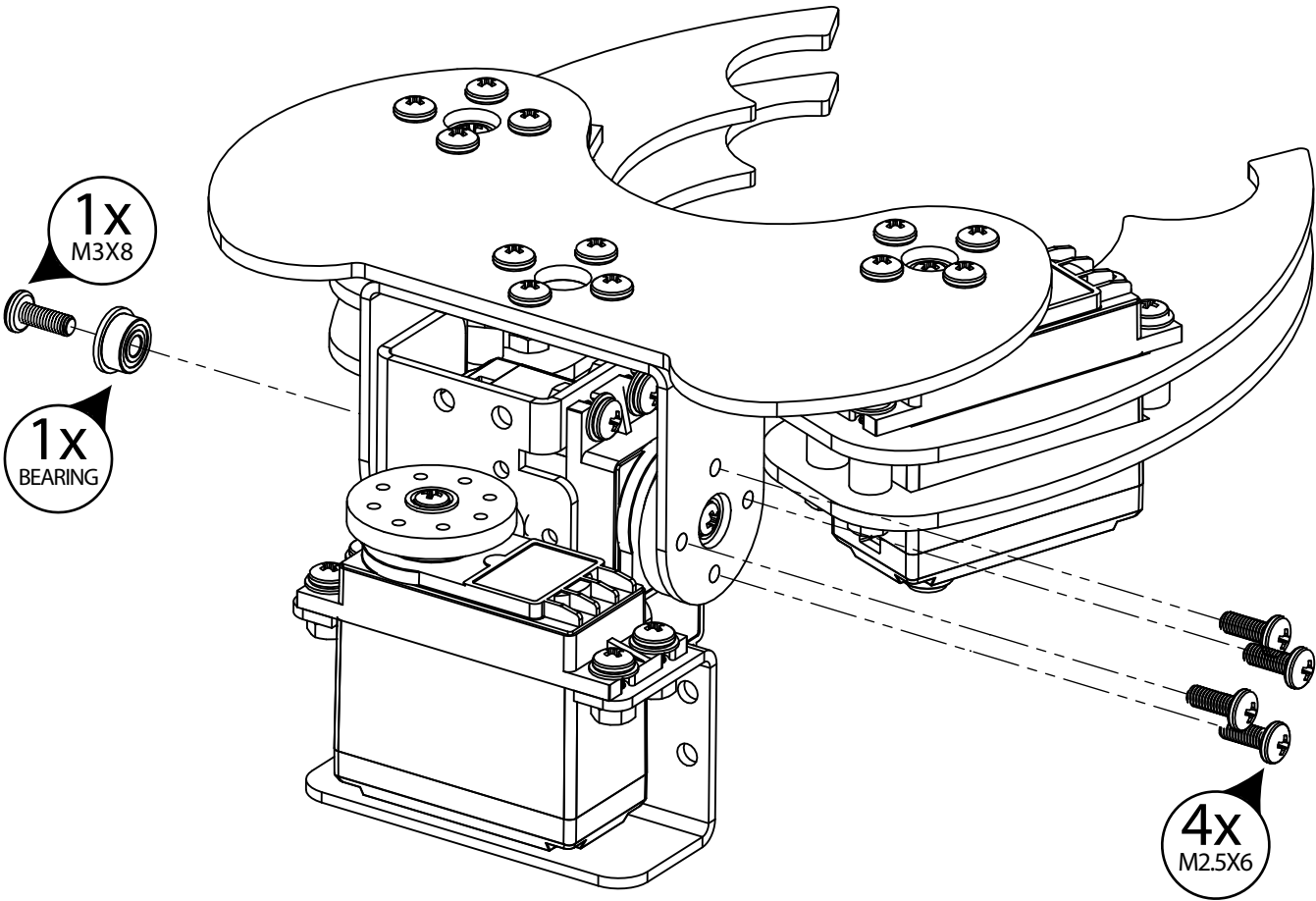

STEP

50

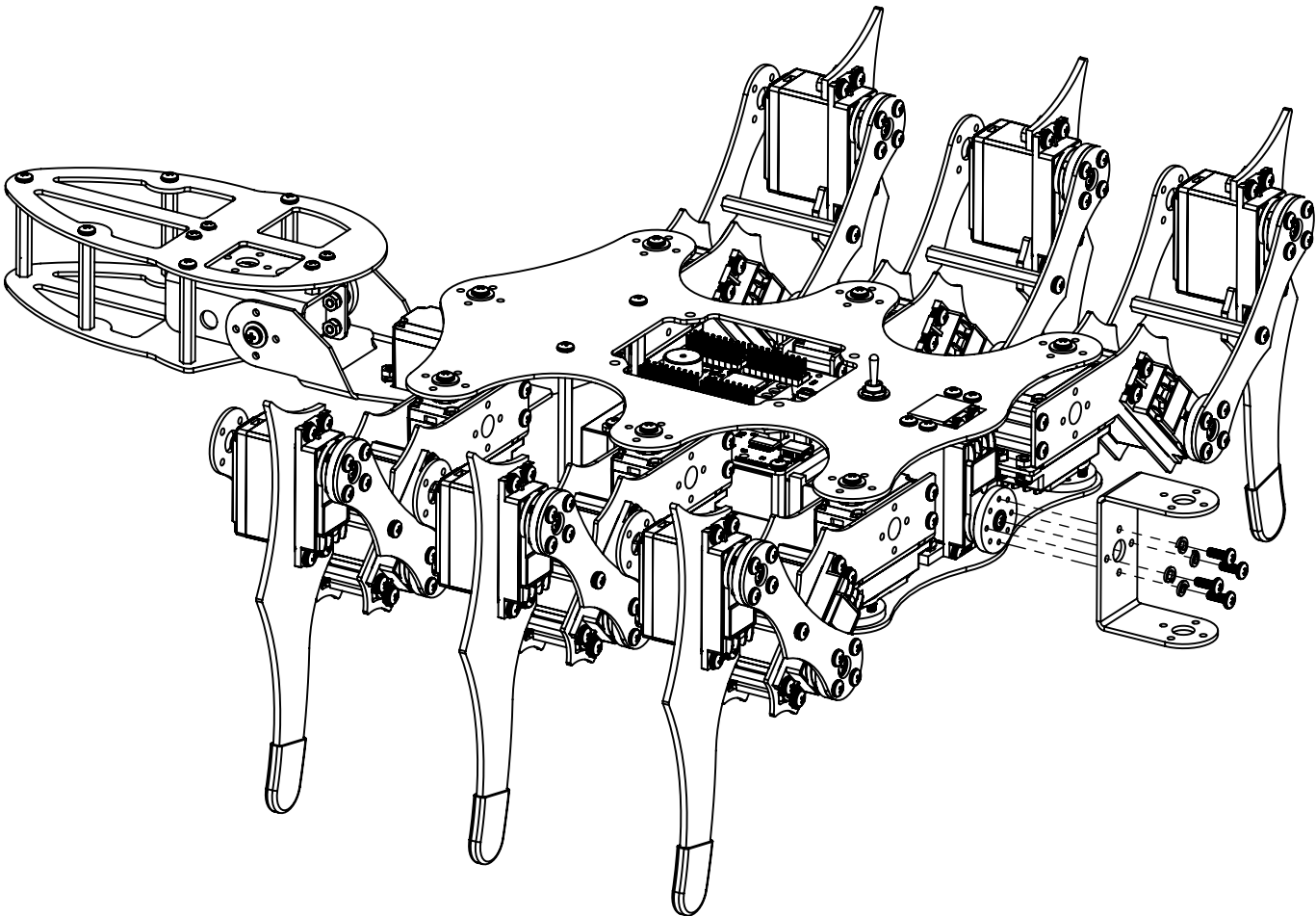

STEP

51

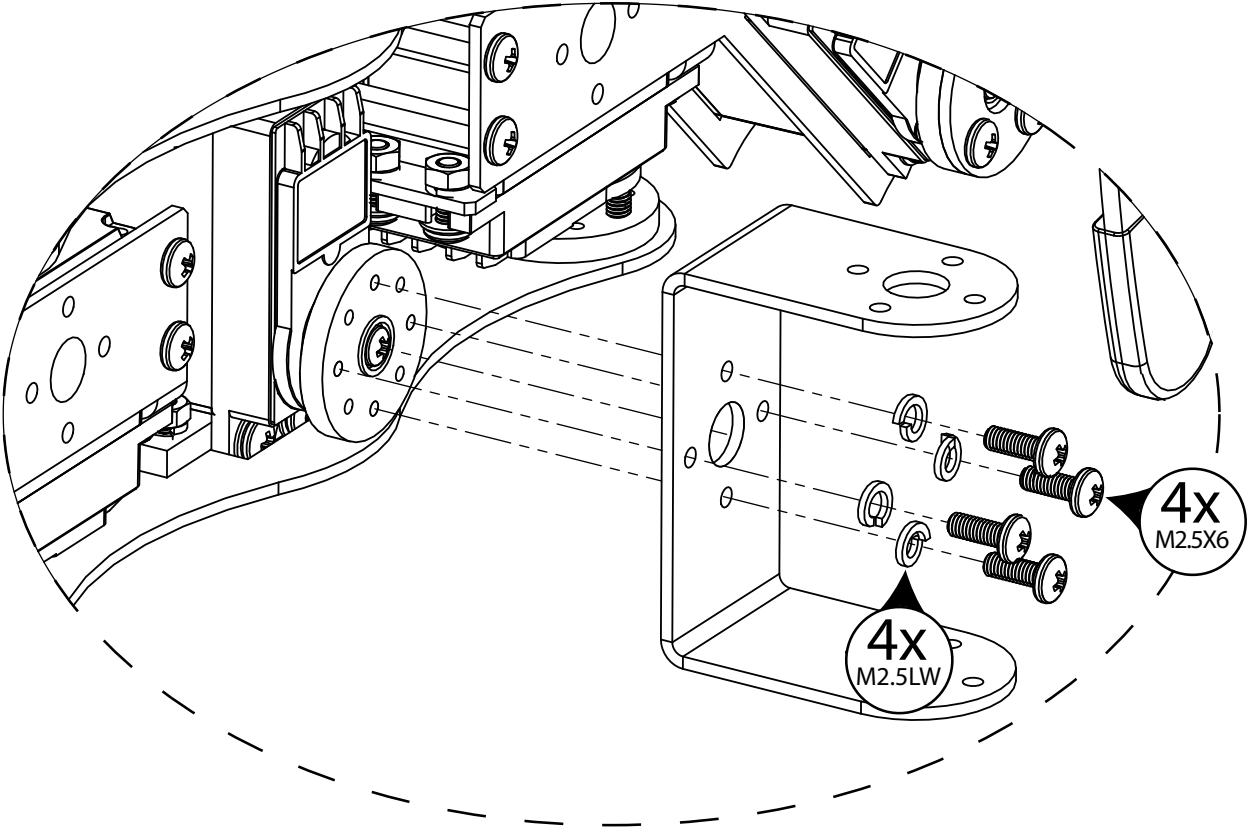

STEP

52

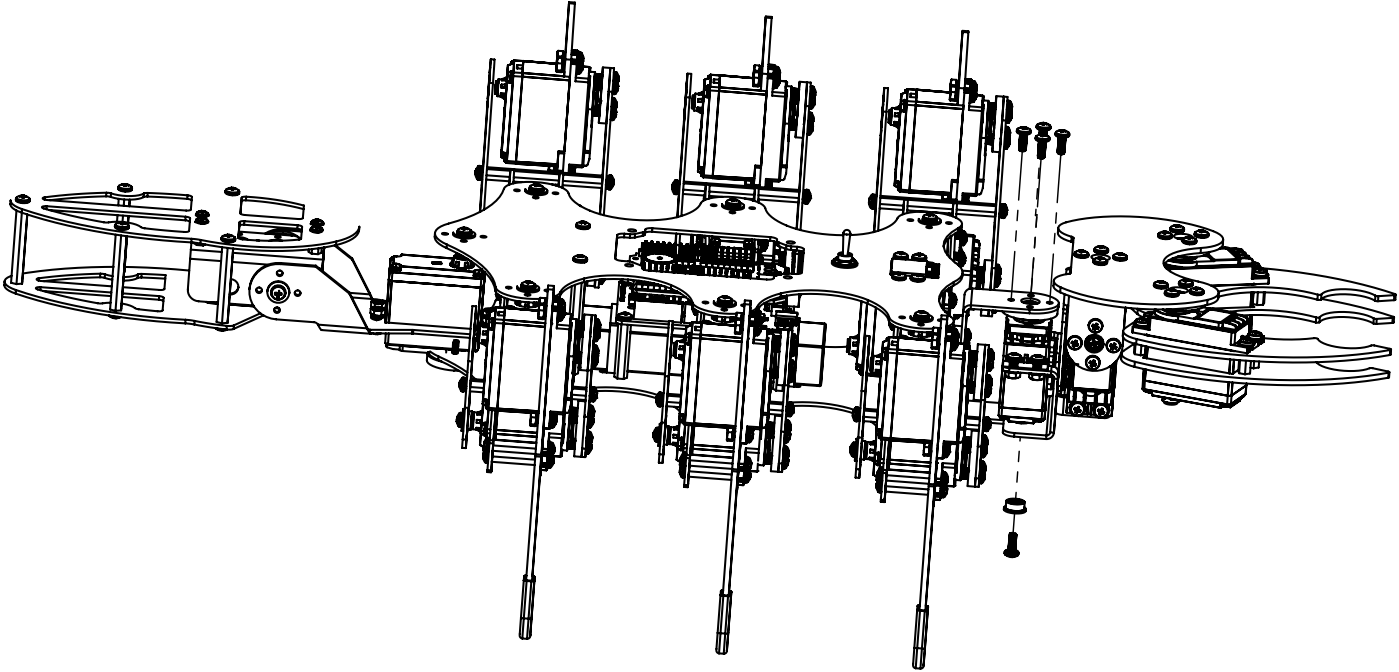

STEP

53

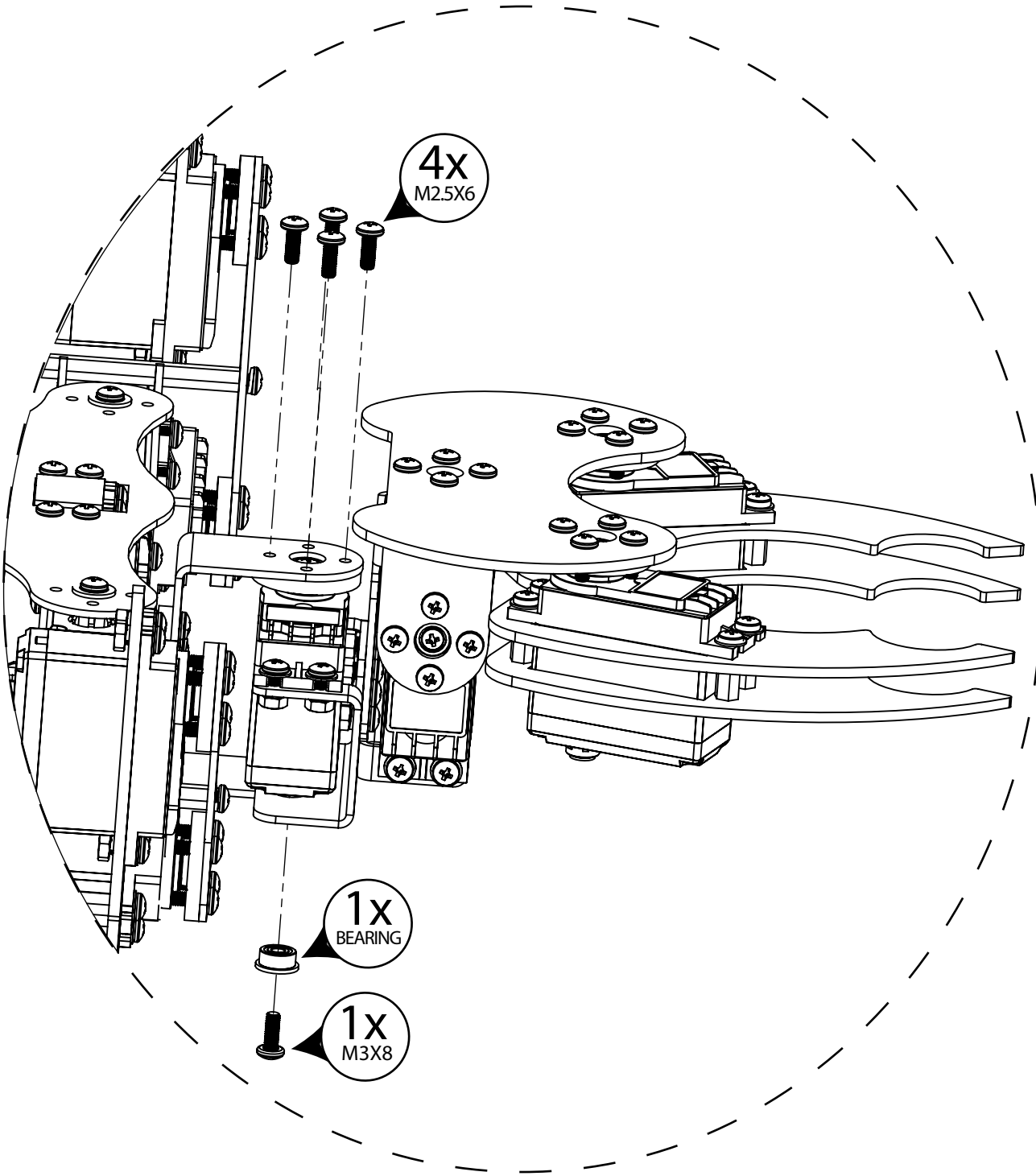

STEP

54

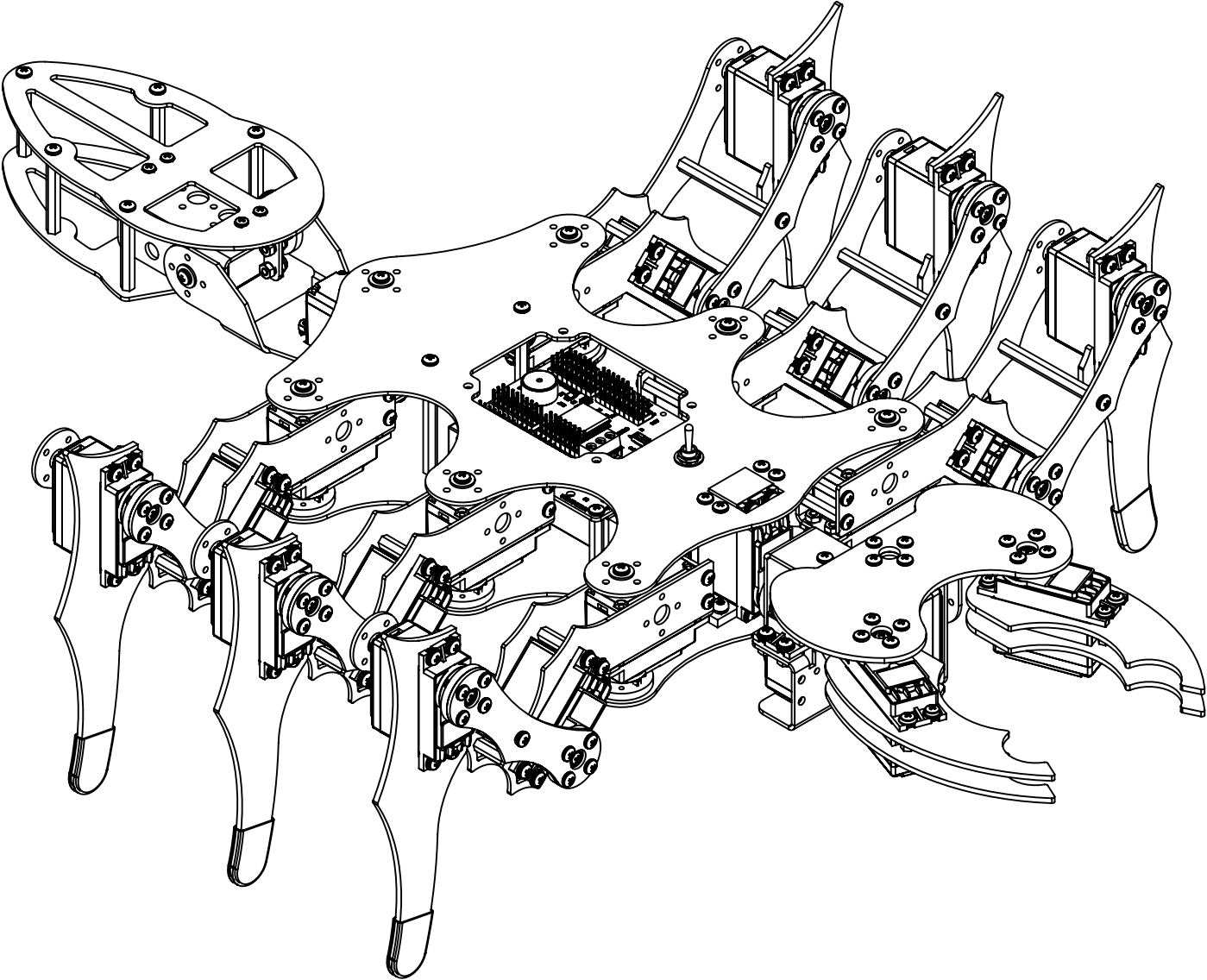

Servo Wiring

After the mechanical assembly of the robot is done all the servos need to be routed to the control electronics. A default wiring configuration is provided in the main program loop. The robot has to be wired based on the default configuration. This configuration can be changed. However it is not recommended.

Servo Wire Routing

When routing servo wires it is important to ensure the wire has enough slack to accommodate the robots full range of movements. You can use zip ties to secure each servo cable. When securing the servo wire make sure it is not on the edge of a bracket or in an area where over time the servo wire can be damaged.

Servo Wiring Table

Use the following table to setup the servo wiring order. The Orion’s servo headers are labeled. Each servo should be routed to its corresponding Orion header as shown in the chart. See the Robot Servo Diagram for servo locations and numbers.

Servo Number	Servo Name	Orion Header
1	Left Front Coxa	23
2	Left Front Femur	22
3	Left Front Tibia	21
4	Left Middle Coxa	20
5	Left Middle Femur	19
6	Left Middle Tibia	18
7	Left Rear Coxa	17
8	Left Rear Femur	16
9	Left Rear Tibia	0
10	Right Front Coxa	15
11	Right Front Femur	14
12	Right Front Tibia	13
13	Right Middle Coxa	12
14	Right Front Femur	11
15	Right Front Tibia	10
16	Right Rear Coxa	9
17	Right Rear Femur	8
18	Right Rear Tibia	1
19	Neck Rotate	7
20	Neck Pan	6
21	Neck Tilt	5
22	Left Pincer	4
23	Right Pincer	3
24	Tail Pan	Ard 10
25	Tail Tilt	Ard 9

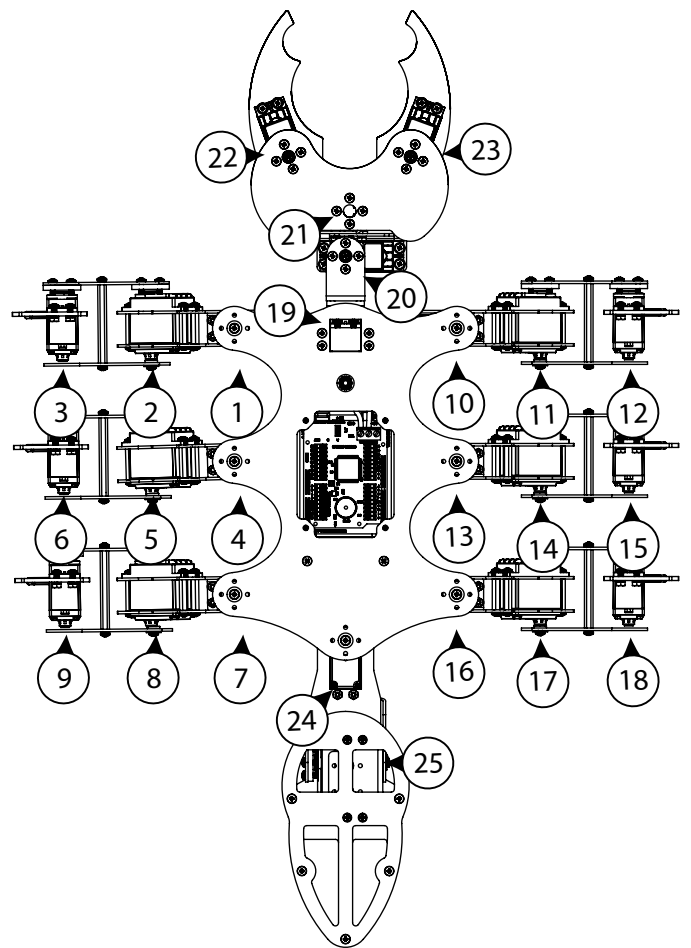

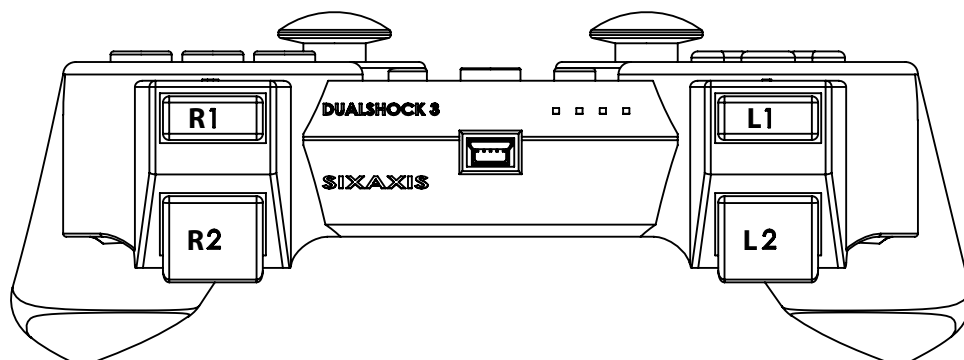
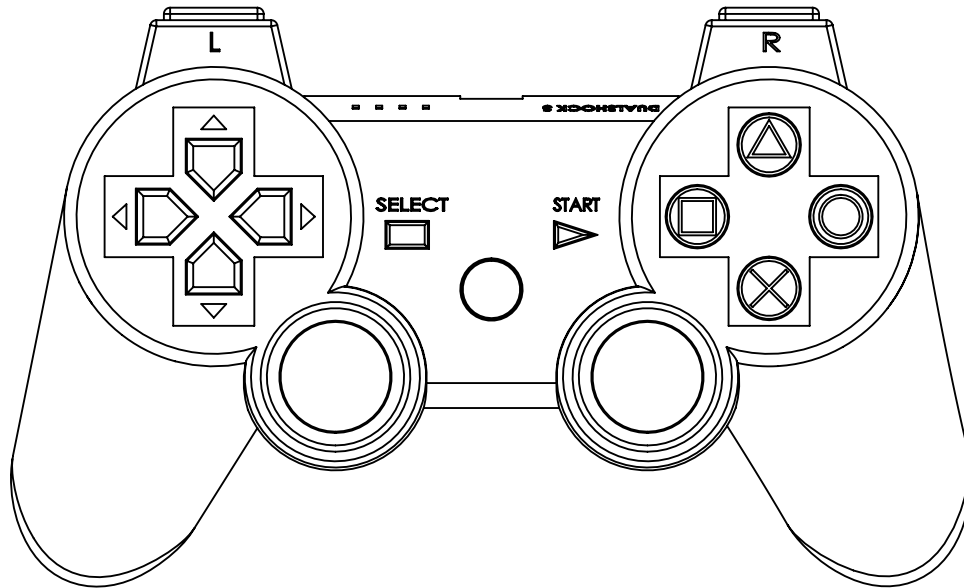

Controller Functions

The following table defines each PS2 controller button function using the default Arduino program.

PS2 Button	Function	Notes
Select	Enter Calibration Mode	
Start	Activate/Deactivate Robot	
Green (Triangle)	Increase Speed	
Blue (X)	Decrease Speed	
Red (Circle)	Next Walking Gait	
Pink (Square)	Previous Walking Gait	
D-Pad Up	Increase Walking Leg Lift	
D-Pad Down	Decrease Walking Leg Lift	
D-Pad Up + L1	Shift Body Up	
D-Pad Down + L1	Shift Body Down	
D-Pad Left	Twist Body Left	
D-Pad Right	Twist Body Right	
Right Joystick Up	Walk Forward/Shift Body Forward	
Right Joystick Down	Walk Backward/Shift Body Backward	
Right Joystick Left	Turn Left/Shift Body Left	
Right Joystick Right	Turn Right/Shift Body Right	
Right Joystick Left + L1	Slide Left/Shift Body Left	
Right Joystick Right + L1	Slide Right/Shift Body Right	
Left Joystick Up	Pitch Body Down	
Left Joystick Down	Pitch Body up	
Left Joystick Left	Roll Body Left	
Left Joystick Right	Roll Body Left	
Left Joystick Up + L1	Shift Body Forward	
Left Joystick Down + L1	Shift Body Backward	
Left Joystick Left + L1	Shift Body Left	
Left Joystick Right + L1	Shift Body Right	
R1	Reset Body Rotation	
R1 + L1	Reset Body Shift	
L2	Open Pincers	
R2	Close Pincers	
L3	Cycle Body Rotation Point	Center, Front, Rear
L3 + L1	Cycle Balance Mode	Off, Shift, Rotate, Both
R3	Toggle Right Joystick Mode	Walk/Body Shift
R3 + L1	Toggle Return to Center	

Enter Calibration Mode

Press the Select button to enter Calibration mode. All servos will deactivate when Calibration Mode is started.

Calibrate Joint Positions

Press the Green/Triangle button to start position calibration. You will hear a beep when pressing the button which indicates the robot is ready for you to adjust the positions.

Move the robot legs head and tail so they match the diagrams below.
Press the Start button to save the settings or press Select to cancel.

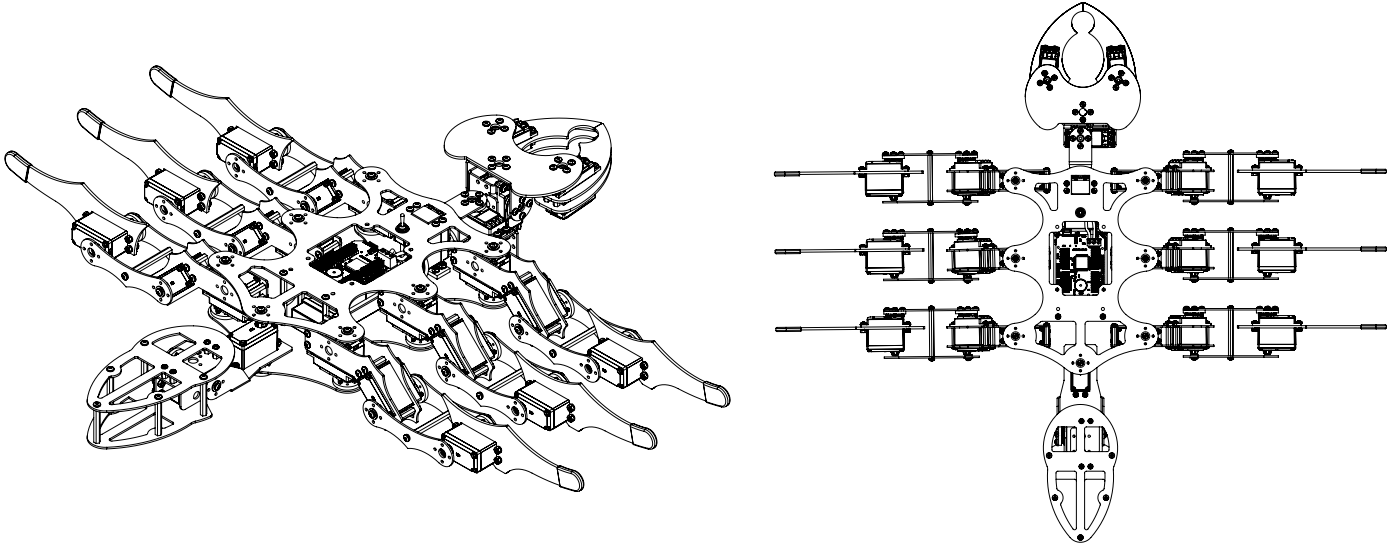
**Calibrate Joint Ranges (HV220 only)**

Press the Blue/Cross button to start range calibration. You will hear a beep when pressing the button which indicates the robot is ready for you to adjust the positions.

Rotate each joint within its full range. The robot microprocessor is tracking these movements and calculating the maximum range for each joint. For example rotate the front left tibia joint clockwise until it stops and then counter clockwise until it stops. Repeat on the other 17 joints. Press the Start button to save or Select to cancel.

Exit Calibration Mode

Press the Red/Circle button to exit from Calibration mode.

Warranty

Orion Robotics warrants its products against defects in material and workmanship for a period of 90 days. If a defect is discovered, Orion Robotics will, at our discretion, repair, replace, or refund the purchase price of the product in question. Contact us at support@orionrobotics.com. No returns will be accepted without the proper authorization.

Copyrights and Trademarks

Copyright© 2012 by Orion Robotics, Inc. All rights reserved. Other trademarks mentioned are registered trademarks of their respective holders.

Disclaimer

Orion Robotics cannot be held responsible for any incidental, or consequential damages resulting from use of products manufactured or sold by Orion Robotics or its distributors. No products from Orion Robotics should be used in any medical devices and/or medical situations. No product should be used in a life support situation.

Contacts

Email: sales@orionrobotics.com
Tech support: support@orionrobotics.com
Web: <http://www.orionrobotics.com>

Discussion List

A web based discussion board is maintained at <http://www.orionrobotics.com>.

Technical Support

Technical support is made available by sending an email to support@orionrobotics.com. All email will be answered within 48 hours. All general syntax and programming questions, unless deemed to be a software issue, will be referred to the on-line discussion forums.