

DATA SHEET

For a complete data sheet, please also download:

- The IC04 LOCMOS HE4000B Logic Family Specifications HEF, HEC
- The IC04 LOCMOS HE4000B Logic Package Outlines/Information HEF, HEC

HEF4060B

MSI

14-stage ripple-carry binary counter/divider and oscillator

Product specification
File under Integrated Circuits, IC04

January 1995

14-stage ripple-carry binary counter/divider and oscillator

HEF4060B MSI

DESCRIPTION

The HEF4060B is a 14-stage ripple-carry binary counter/divider and oscillator with three oscillator terminals (RS, R_{TC} and C_{TC}), ten buffered outputs (O₃ to O₉ and O₁₁ to O₁₃) and an overriding asynchronous master reset input (MR). The oscillator configuration allows design of either RC or crystal oscillator circuits. The oscillator may

be replaced by an external clock signal at input RS. The counter advances on the negative-going transition of RS. A HIGH level on MR resets the counter (O₃ to O₉ and O₁₁ to O₁₃ = LOW), independent of other input conditions. Schmitt-trigger action in the clock input makes the circuit highly tolerant to slower clock rise and fall times.

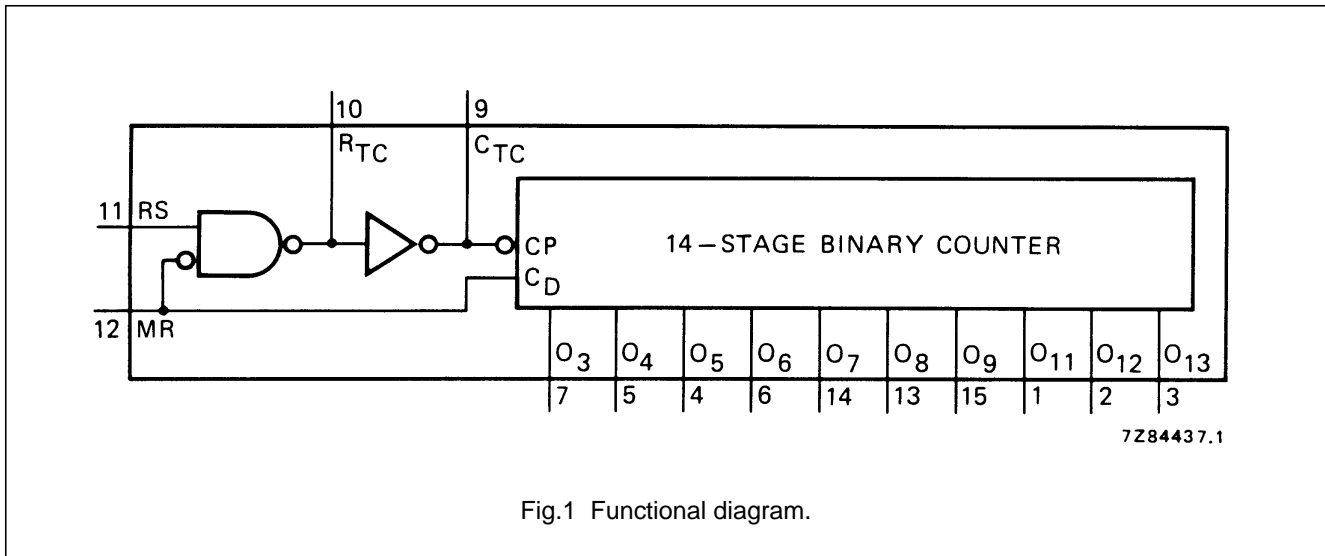

Fig.1 Functional diagram.

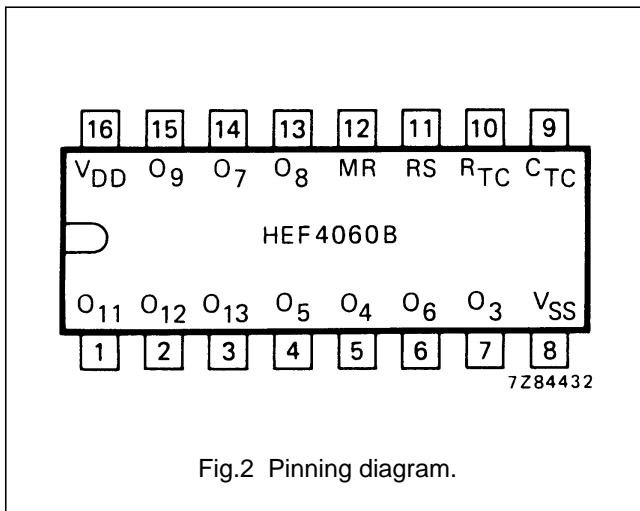

Fig.2 Pinning diagram.

PINNING

- MR master reset
- RS clock input/oscillator pin
- R_{TC} oscillator pin
- C_{TC} external capacitor connection
- O₃ to O₉ counter outputs
- O₁₁ to O₁₃ counter outputs

- HEF4060BP(N): 16-lead DIL; plastic (SOT38-1)
- HEF4060BD(F): 16-lead DIL; ceramic (cerdip) (SOT74)
- HEF4060BT(D): 16-lead SO; plastic (SOT109-1)
- (): Package Designator North America

FAMILY DATA, I_{DD} LIMITS category MSI

See Family Specifications

14-stage ripple-carry binary counter/divider and oscillator

HEF4060B MSI

AC CHARACTERISTICS

$V_{SS} = 0$ V; $T_{amb} = 25$ °C; $C_L = 50$ pF; input transition times ≤ 20 ns

	V_{DD} V	SYMBOL	MIN.	TYP.	MAX.	TYPICAL EXTRAPOLATION FORMULA			
Propagation delays	5	t_{PHL}		210	420	ns	$183 \text{ ns} + (0,55 \text{ ns/pF}) C_L$		
				RS \rightarrow O ₃	80	160		ns	$69 \text{ ns} + (0,23 \text{ ns/pF}) C_L$
				HIGH to LOW	50	100		ns	$42 \text{ ns} + (0,16 \text{ ns/pF}) C_L$
	LOW to HIGH	10	t_{PLH}		210	420	ns	$183 \text{ ns} + (0,55 \text{ ns/pF}) C_L$	
					80	160	ns		$69 \text{ ns} + (0,23 \text{ ns/pF}) C_L$
					50	100	ns		$42 \text{ ns} + (0,16 \text{ ns/pF}) C_L$
	O _n \rightarrow O _{n+1}	5	t_{PHL}		25	50	ns		
					HIGH to LOW	10	20		ns
					6	12	ns		
		LOW to HIGH	10	t_{PLH}		25	50		ns
						10	20		ns
						6	12		ns
MR \rightarrow O _n	15	t_{PHL}		100	200	ns	$73 \text{ ns} + (0,55 \text{ ns/pF}) C_L$		
				HIGH to LOW	40	80		ns	$29 \text{ ns} + (0,23 \text{ ns/pF}) C_L$
				30	60	ns		$22 \text{ ns} + (0,16 \text{ ns/pF}) C_L$	
Output transition times	5	t_{THL}		60	120	ns	$10 \text{ ns} + (1,0 \text{ ns/pF}) C_L$		
				HIGH to LOW	30	60		ns	$9 \text{ ns} + (0,42 \text{ ns/pF}) C_L$
				20	40	ns		$6 \text{ ns} + (0,28 \text{ ns/pF}) C_L$	
	LOW to HIGH	10	t_{TLH}		60	120	ns	$10 \text{ ns} + (1,0 \text{ ns/pF}) C_L$	
					30	60	ns		$9 \text{ ns} + (0,42 \text{ ns/pF}) C_L$
					20	40	ns		$6 \text{ ns} + (0,28 \text{ ns/pF}) C_L$
Minimum clock pulse width input RS	15	t_{WRSH}		120	60	ns			
				HIGH	50	25		ns	
				30	15	ns			
Minimum MR pulse width; HIGH	5	t_{WMRH}		50	25	ns			
				10	30	15		ns	
				15	20	10		ns	
Recovery time for MR	10	t_{RMR}		160	80	ns			
				80	40	ns			
				60	30	ns			
Maximum clock pulse frequency input RS	5	f_{max}		4	8	MHz			
				10	10	20		MHz	
				15	15	30		MHz	

14-stage ripple-carry binary counter/divider
and oscillator

HEF4060B
MSI

AC CHARACTERISTICS

$V_{SS} = 0\text{ V}$; $T_{amb} = 25\text{ }^\circ\text{C}$; input transition times $\leq 20\text{ ns}$

	V_{DD} V	TYPICAL FORMULA FOR P (μW) ⁽¹⁾
Dynamic power dissipation per package (P)	5	$700 f_i + f_o C_L V_{DD}^2$
	10	$3\,300 f_i + f_o C_L V_{DD}^2$
	15	$8\,900 f_i + f_o C_L V_{DD}^2$
Total power dissipation when using the on-chip oscillator (P)	5	$700 f_{osc} + f_o C_L V_{DD}^2 + 2C_t V_{DD}^2 f_{osc} + 690 V_{DD}$
	10	$3\,300 f_{osc} + f_o C_L V_{DD}^2 + 2C_t V_{DD}^2 f_{osc} + 6\,900 V_{DD}$
	15	$8\,900 f_{osc} + f_o C_L V_{DD}^2 + 2C_t V_{DD}^2 f_{osc} + 22\,000 V_{DD}$

Notes

1. where:

f_i = input frequency (MHz)

f_o = output frequency (MHz)

C_L = load capacitance (pF)

V_{DD} = supply voltage (V)

C_t = timing capacitance (pF)

f_{osc} = oscillator frequency (MHz)

RC oscillator

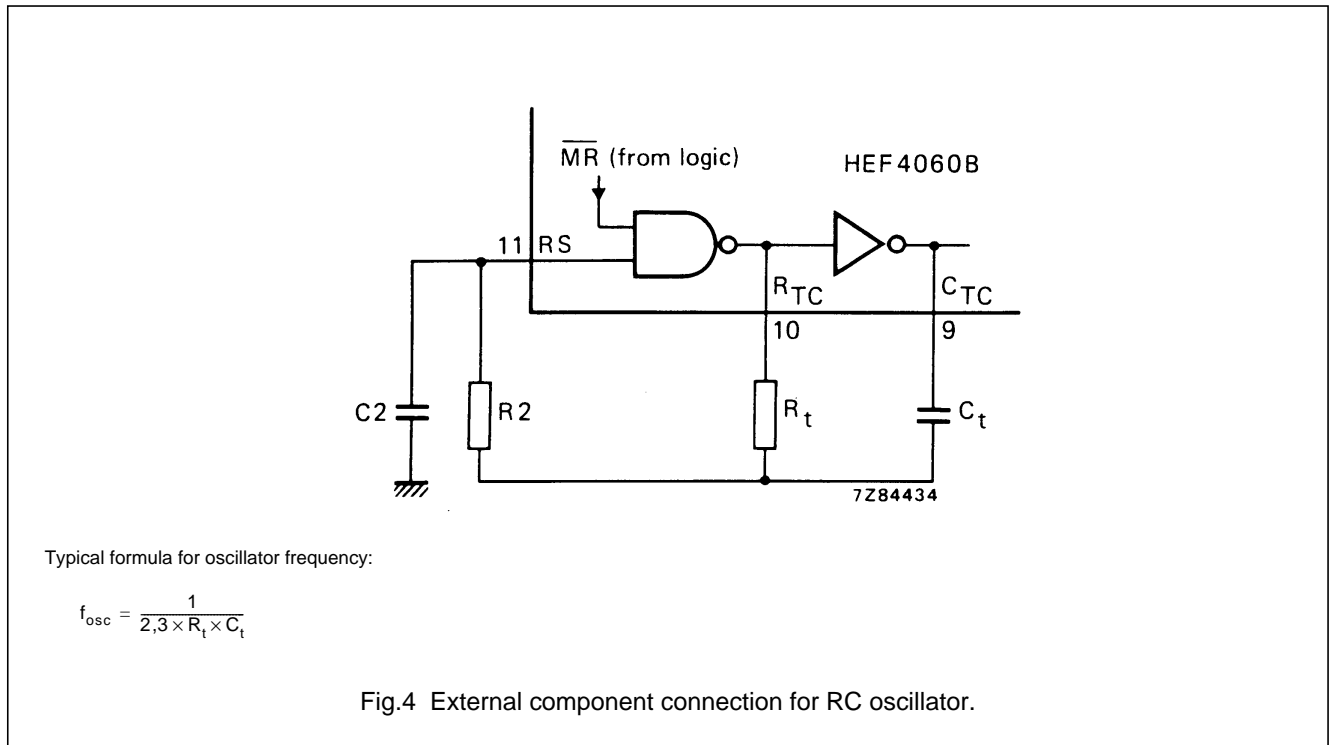

14-stage ripple-carry binary counter/divider and oscillator

HEF4060B
MSI

Timing component limitations

The oscillator frequency is mainly determined by $R_t C_t$, provided $R_t \ll R_2$ and $R_2 C_2 \ll R_t C_t$. The function of R_2 is to minimize the influence of the forward voltage across the input protection diodes on the frequency. The stray capacitance C_2 should be kept as small as possible. In consideration of accuracy, C_t must be larger than the inherent stray capacitance. R_t must be larger than the LOCMOS 'ON' resistance in series with it, which typically is 500 Ω at $V_{DD} = 5$ V, 300 Ω at $V_{DD} = 10$ V and 200 Ω at $V_{DD} = 15$ V.

The recommended values for these components to maintain agreement with the typical oscillation formula are:

$C_t \geq 100$ pF, up to any practical value,
 10 k $\Omega \leq R_t \leq 1$ M Ω .

Typical crystal oscillator circuit

In Fig.5, R_2 is the power limiting resistor. For starting and maintaining oscillation a minimum transconductance is necessary.

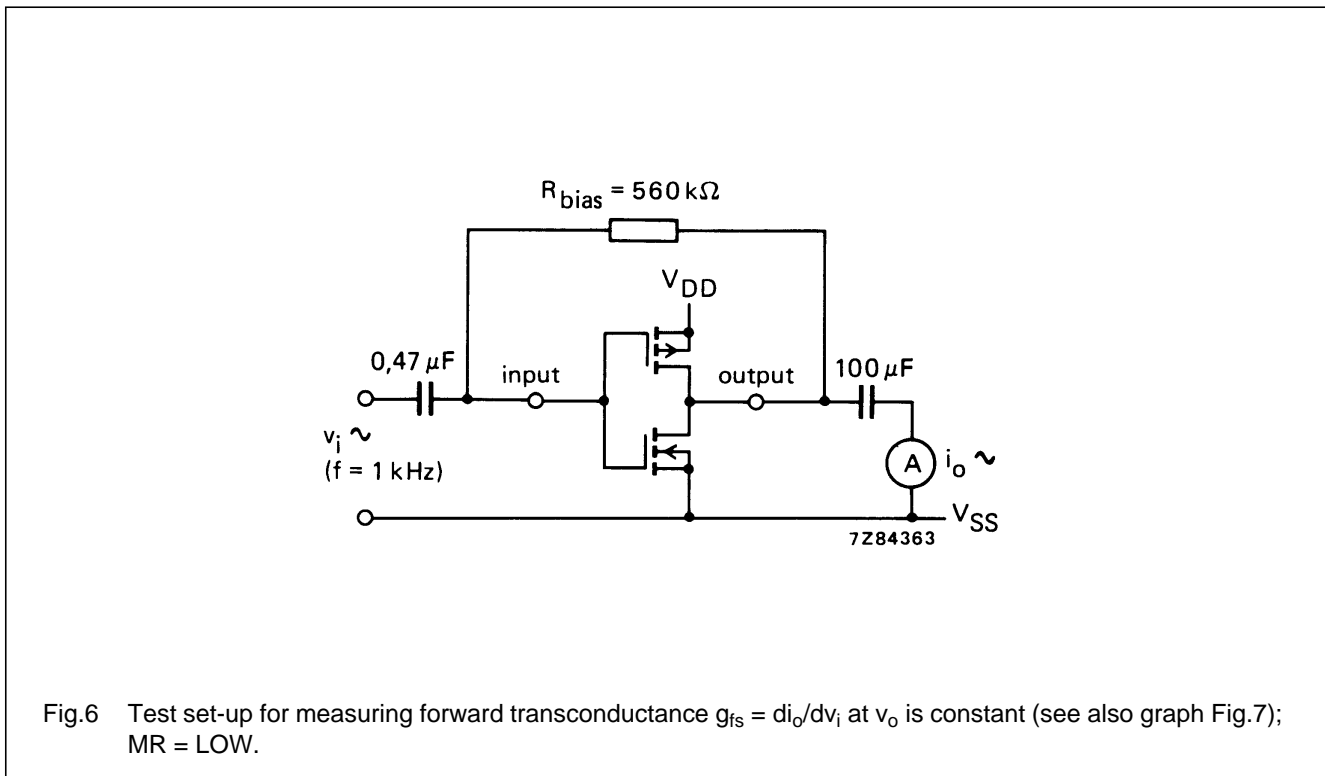
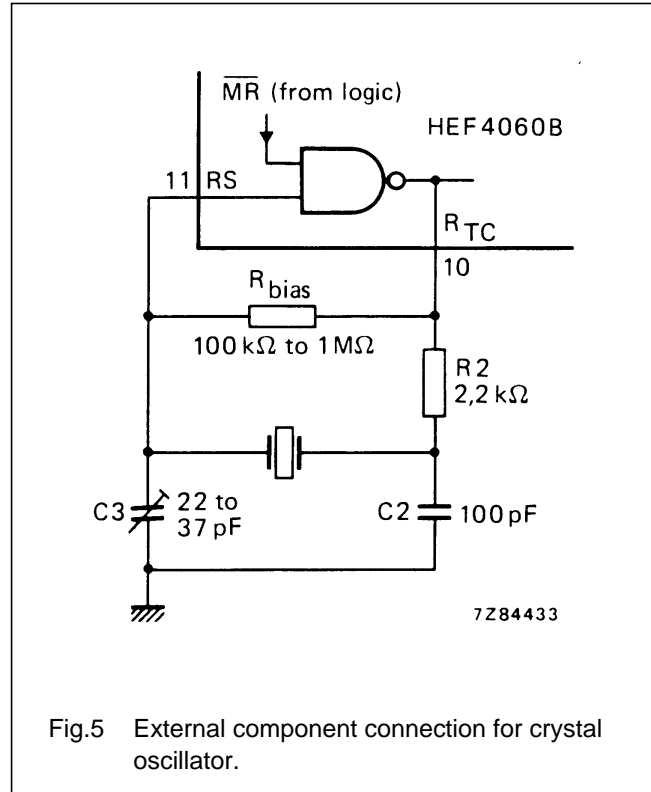

14-stage ripple-carry binary counter/divider
and oscillator

HEF4060B
MSI

