

Hybrid Stepping Motor 42BYGH721

Номер Модели: 42BYGH721
 Тип: Шаговый гибридный мотор
 Кол-во Фаз: 3
 Угол Шага (градусы): 1,8
 Крутящий момент: 2000 g./cm
 Фиксирующий момент: 250 g./cm
 Ток / Фаза: 0.25A
 Номинальное напряжение: 10V
 Сопротивление фазы: 40
 Кол-во проводов: 6
 Длина мотора: 44 мм
 Мотор Вес: 0,3 кг
 Сертификация: CE, ISO

Точность шага: $\pm 5\%$
 Temperature Rise: 80°C Max
 Ambient Temperature Range: -20°C ~ +50°C
 Insulation Resistance: 100 MΩ Min. 500 VDC
 Dielectric Strength: 500 VAC 1 minute



外型图 Mechanical Dimensions

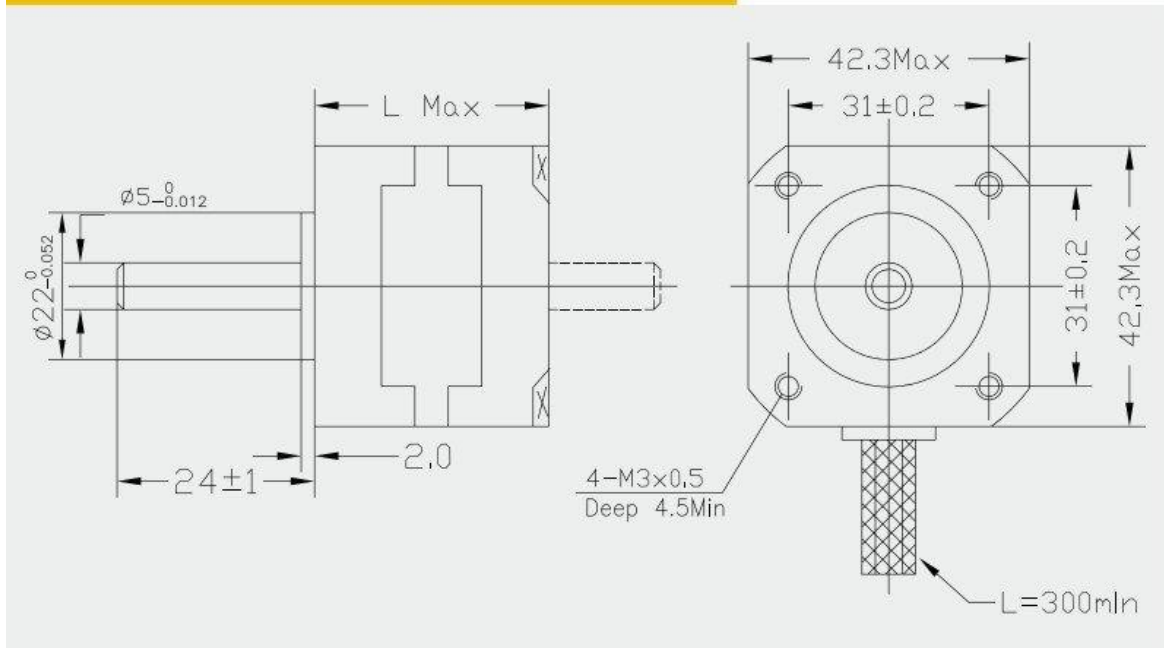

Wiring diagram for 42BYG series step motor

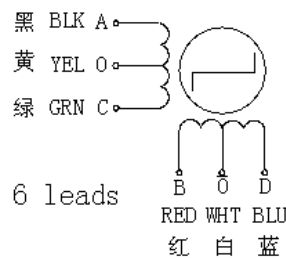
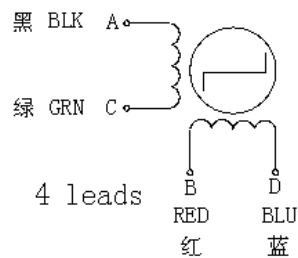

Specifications for 42BYG series step motor

Model	Step angle	Motor Length	Rated Voltage	Rated Current	Phase Resistance	Phase Inductance	Holding Torque	Lead Wire	Rotor Inertia	Detent Torque	Motor Weight
	(°)	(mm)	(V)	(A)	(Ω)	(mH)	(g.cm)	(NO.)	(g.cm ²)	(g.cm)	(kg)
42BYGH201	1.8	34	12	0.16	75	42	950	5	34	200	0.2
42BYGH202	1.8	34	12	0.3	40	22	1250	6	34	200	0.2
42BYGH610	1.8	40	6.5	1.2	6	13	3000	4	54	220	0.24
42BYGH613	1.8	40	2.4	1.7	1.5	2.5	3500	4	54	220	0.24
42BYGH616	1.8	40	4.1	0.5	8	15	2600	4	54	220	0.24
42BYGH718	1.8	44	8.9	0.5	18	23	2900	6	50	250	0.3
42BYGH721	1.8	44	10	0.25	40	36	2000	6	50	250	0.3
42BYGH801	1.8	48	12	0.4	30	28	3800	6	68	280	0.34
42BYGH803	1.8	48	5.6	0.8	7	4	2600	6	68	280	0.34