

Via Monfalcone 41
20092 Cinisello Balsamo (Milano) – Italy
Tel. +39 0266013695 – Fax +39 0266013530

MODEL NO: KCLP1279CR Series

SUBJECT: **Philips Lumileds LUXEON[®] Rebel LEDs – Lens Coupling - Output Luminous Intensity Measurement**

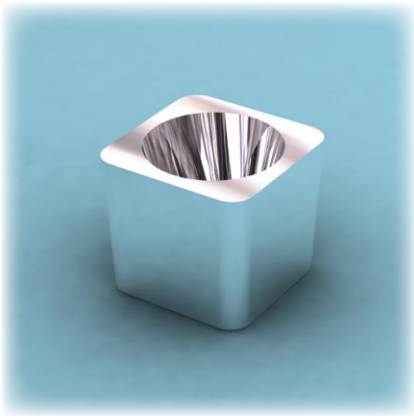

KCLP1279CR Series for Rebel

- High efficiency
- Very narrow spot
- High Uniformity

Typical applications are

- Wall Washer
- Accent Lighting
- Micro Torcics
- Most applications where a compact light source is required

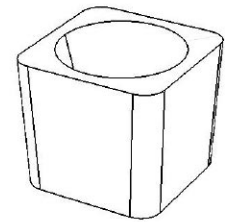

DESCRIPTION:

The luminous intensity test has been carried out by coupling Khatod Lenses with LUXEON[®] Rebel LED: LXML-PWN1-0080.

REPORT:

From 1 m ± 0,02 distance, we have measured Luminous Intensity emitted by LED. Such measurements have been repeated with the same test conditions but coupling LEDs to the reflector Khatod cod. KCLP1279CR.

MEASURED DATA:

Column 1 shows p/n of the Reflector, column 2 shows Luminous Intensity detected measuring LEDs without reflector, column 3 shows Luminous Intensity detected on LEDs coupled with reflector, column 4 shows the difference (X*) between col. 2 and col. 3

| Reflector Type | LED Lux from 1 Mt (ftc From 1 Mt) | LED + reflector Lux from 1Mt (ftc From 1 Mt) | X* |
|---|---|--|----|
| KCLP1279CR (10°) | 44 (4,06 ftc) | 877 (80,94 ftc) | 20 |
| Test carried out after 5 min. of operation of the LED to 700 mA ~ , local power source GOSSEN KONSTANTER mod 3226-K118 Measurements carried out with Luxometer mod LUX-1337 of ISO-TEC and MINOLTA mod LS – 150 * X is the value of the measurement of the LED brightness at 1 meter distance, without optic devices applied to the LED. | | | |

White LED Illuminance chart

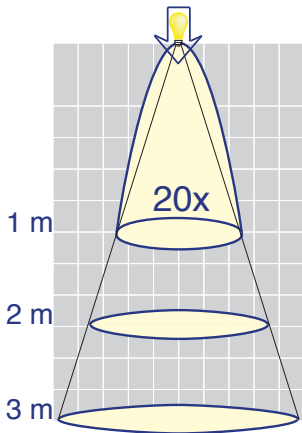

KCLP1279CR (10°)

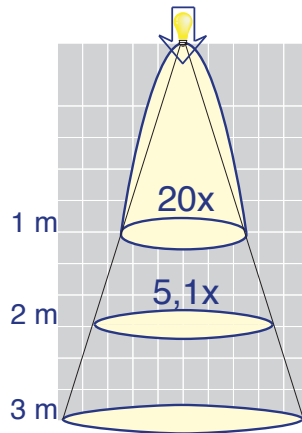

KCLP1279CR (10°)

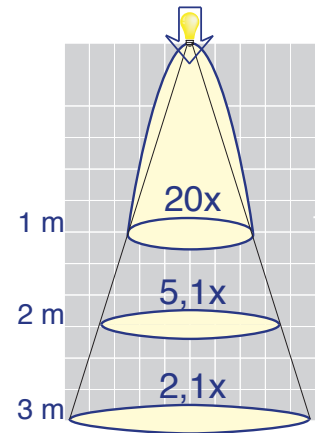

KCLP1279CR (10°)

* X is the value of the measurement of the LED brightness at 1 meter distance, without optic devices applied to the LED.

Test conditions:

Test current: 700 mA / LED

Room Luminous Intensity : 0 Lumen

Room Temperature: 24° C

LED temperature after 10 min. : ~ 51 °C

The diagram demonstrates the performance of the Khatod optoelectronic reflector

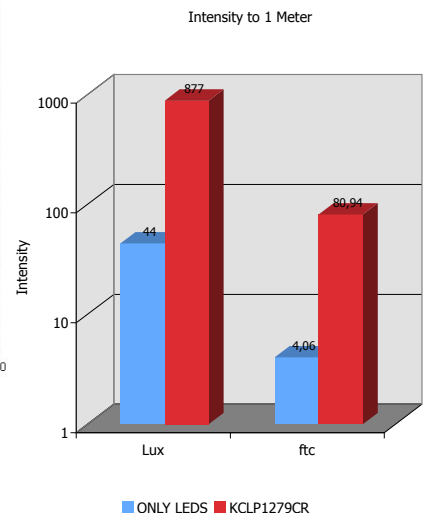
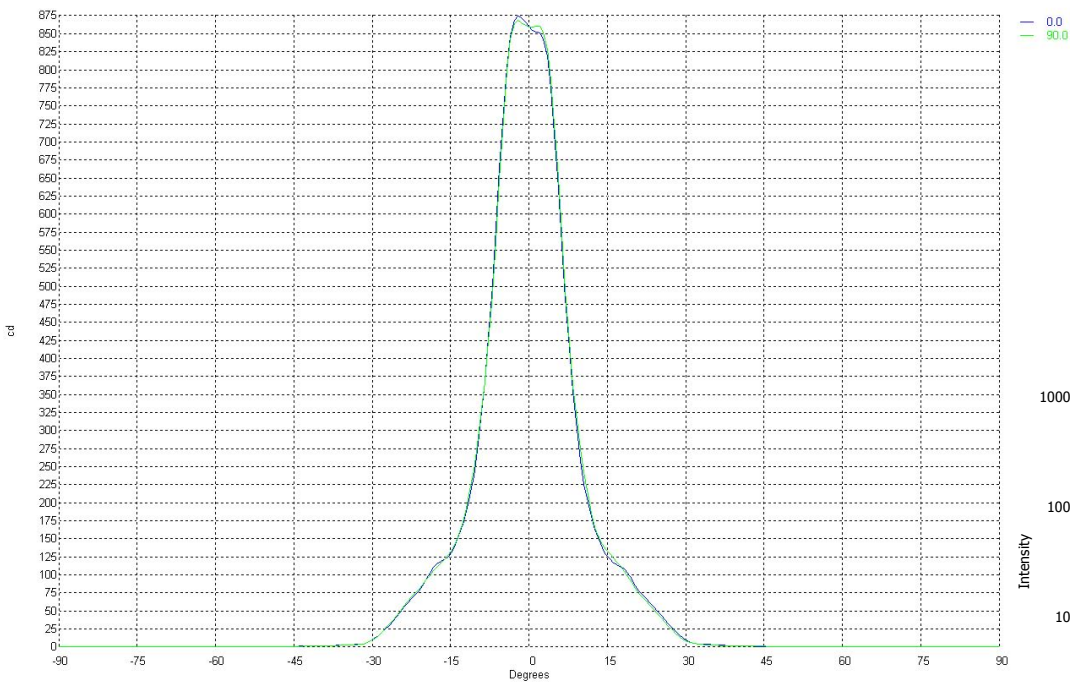

Photos:

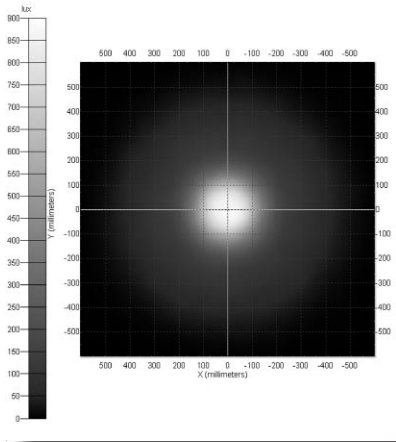

KCLP1279CR
Target at 1 Meter (10°)

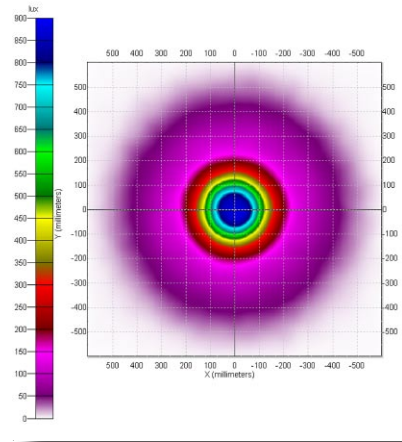

Spectro Metric Analysis
Target at 1 Meter (10°)

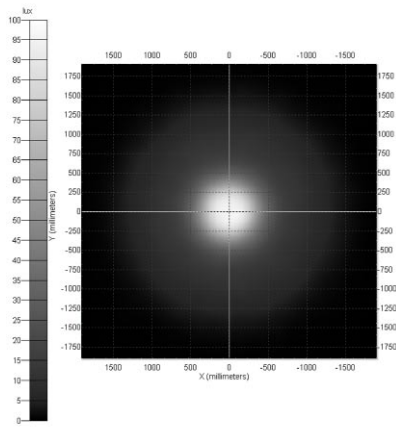

KCLP1279CR
Target at 3 Meters (10°)

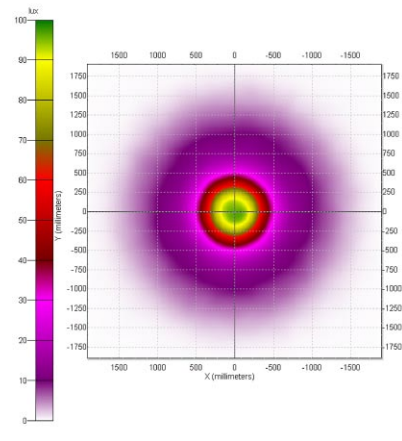

Spectro Metric Analysis
Target at 3 Meters (10°)

Measurements carried out with Luxometer mod LUX-1337. Room Luminous Intensity: 0 Lumen. Camera mod. Fujifilm S7000

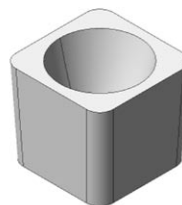
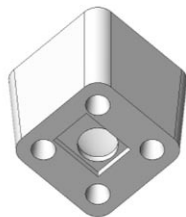

Drawing.

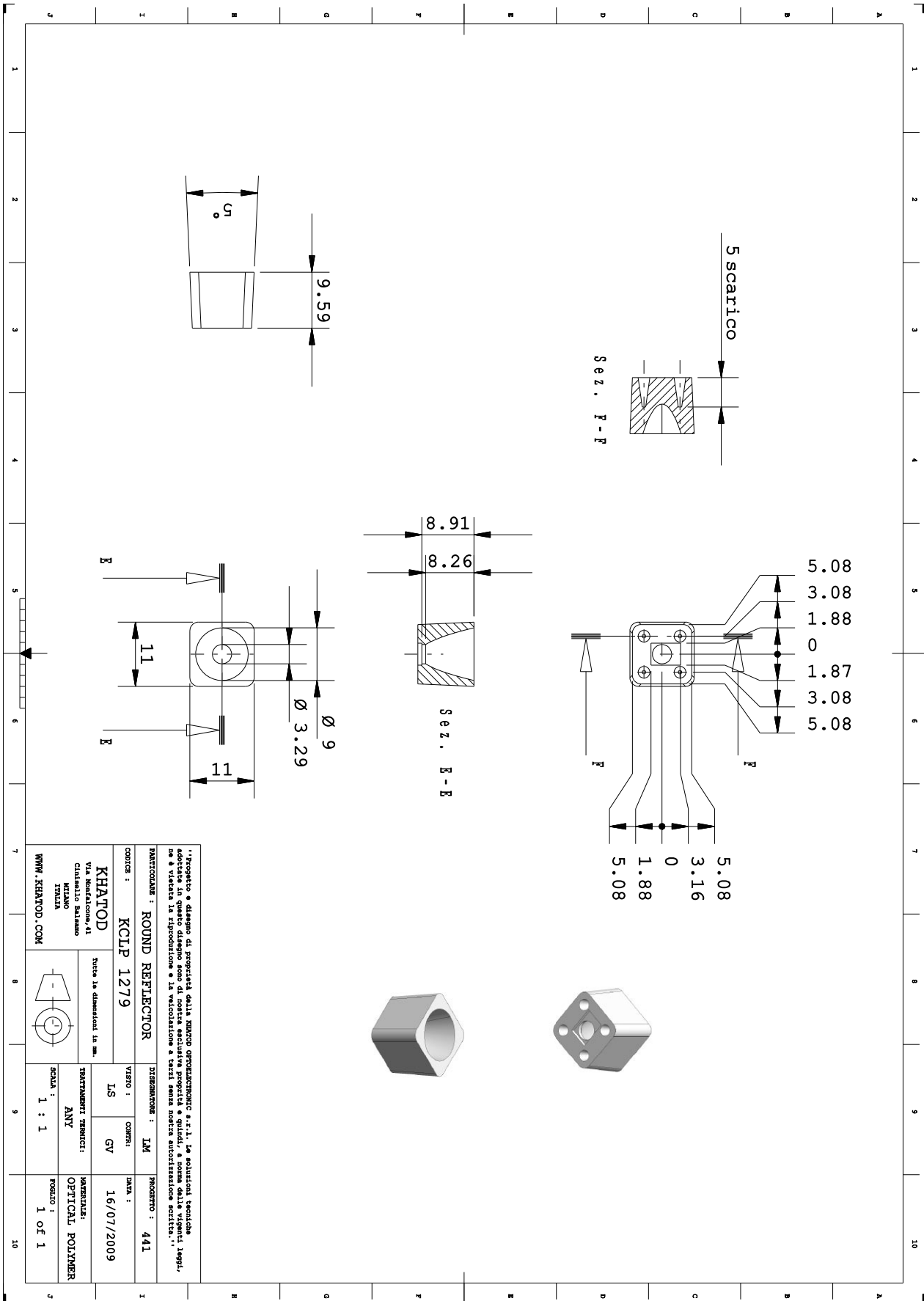

Progetto e disegno di proprietà della KHATOD OPTOELECTRONIC s.r.l. Le soluzioni tecniche adottate in questo disegno sono di nostra esclusiva proprietà e quindi, a norma delle vigenti leggi, ne è vietata la riproduzione e la valorizzazione e terzi senza nostra autorizzazione scritta.

| | | | | | |
|---|--|---------------------------|--|-----------------------------|--|
| PARTICOLARE : ROUND REFLECTOR | | DESCRIZIONE : IM | | PROGETTO : 441 | |
| CODICE : KCIP 1279 | | VERSIONE : IS | | DATA : 16/07/2009 | |
| KHATOD Via Montalione, 41 Castellino Balone 47014 TUSCANI WWW.KHATOD.COM | | TRATTAMENTI TERMICI : ANY | | MATERIALE : OPTICAL POLYMER | |
| Tutte le dimensioni in mm. | | SCALA : 1 : 1 | | FOGLIO : 1 OF 1 | |

Reflector characteristics

| Parameter | Symbol | Rating | Unit |
|-----------------------|--|-------------|------|
| Reflector Material | PC Polycarbonate, Aluminium reflective coating with protective clear-coat | -- | -- |
| Operating Temperature | Topr | -40 to +100 | °C |
| Storage Temperature | Tstg | -40 to +100 | °C |

LED characteristics

For technical specification on LEDs, please refer to LUXEON[®] LEDs datasheet or visit www.luxeon.com

Notes:

Please note that flow lines and weld lines on the external surfaces of the reflector are acceptable if the optical performance of the reflector is within the specification described in the section "OPTICAL CHARACTERISTICS"

- Should you require further information, please contact Khatod for advice.
- All reflector testing must be subject to identical conditions as Khatod test condition.
- Published by Khatod optoelectronic srl - All the data contained in this document are the property of Khatod optoelectronic srl and may change without notice.

KHATOD Reflector Use And Maintenance

- DO NOT HANDLE OR INSTALL Reflector WITHOUT WEARING GLOVES, SKIN OILS MAY DAMAGE Reflector OR LIGHT TRANSMISSION
- CLEAN Reflector WITH MILD SOAP AND WATER AND A SOFT CLOTH
- DO NOT USE ANY COMMERCIAL CLEANING SOLVENTS ON Reflector

Khatod SRL, Milan, Italy, manufactures reflector for LEDs. Any other use of the reflector shall void our liability and warranty. The reflector are an inert component to be used in the manufacture of various products. Our warranty and liability are limited only to the manufacture of the reflector. You may not modify, copy, distribute reproduce, license or alter the reflector and related materials of Khatod SRL. Khatod SRL does not warrant against damages or defects arising out of the use or misuse of the products; against defects or damage arising from improper installation, or against defects in the product or in its components. No warranty of any kind, expressed or implied, is made regarding the safety of the products. The entire risk as to the quality or performance of the product is with the buyer. In no event shall Khatod SRL or Khatod USA be liable for any direct, indirect, punitive, incidental, special, consequential damages, or any damages whatsoever arising out of or connected with the use or misuse of the product. Khatod SRL shall not have any obligation with respect to the product or any part thereof, whether based on contract, tort, strict liability or otherwise. Buyer assumes all risks and liability from use of the product. The laws of Milan, Italy govern this product warranty and liability and you hereby consent to the exclusive jurisdiction and venue of courts in Milan, Italy in all disputes arising out of or relating to the use of this product.

