

**LA7642N****SECAM Format Color TV Chrominance Circuit****Overview**

The LA7642N integrates the chrominance circuit for a SECAM format TV in a single 16-pin DIP (300 mil) package and provides an adjustment-free discriminator circuit. In combination with the Sanyo LA7687, LA7688, this IC can implement a multi-format color TV signal-processing system.

**Features**

- Adjustment-free discriminator circuit
- On-chip bell filter

**Package Dimensions**

unit: mm

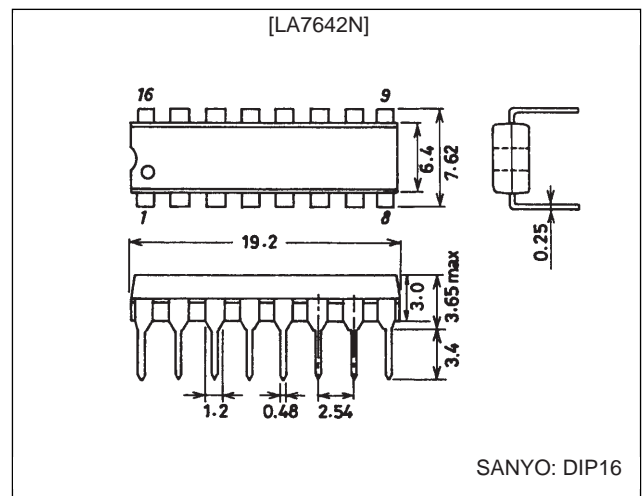
**3006B-DIP16****Specifications****Maximum Ratings at Ta = 25°C**

Parameter	Symbol	Conditions	Ratings	Unit
Maximum supply voltage	V <sub>CC</sub> max		9	V
Allowable power dissipation	P <sub>d</sub> max	T <sub>a</sub> ≤ 65°C	400	mW
Operating temperature	T <sub>opr</sub>		-10 to +65	°C
Storage temperature	T <sub>stg</sub>		-55 to +125	°C

**Operating Conditions at Ta = 25°C**

Parameter	Symbol	Conditions	Ratings	Unit
Recommended operating voltage	V <sub>CC</sub>		7.8	V
Operating voltage range	V <sub>CC</sub> op		7.0 to 8.5	V

**Operating Characteristics at Ta = 25°C, V<sub>CC</sub> = 7.8 V, with pin 13 pulled up to V<sub>CC</sub> through a 20-kΩ resistor**

Parameter	Symbol	Conditions	Ratings			Unit
			min	typ	max	
[Circuit Voltage and Current]						
Circuit current	I <sub>CC</sub>	Chrominance system. Measure the current flowing into pin 15; With no signal applied to pin 14.	28	35	42	mA
[Filter Block]						
Input impedance		The pin 14 input impedance. For reference only (design value)		15		kΩ

Continued on next page.

## LA7642N

Continued from preceding page.

Parameter	Symbol	Conditions	Ratings			Unit
			min	typ	max	
Bell filter frequency characteristics 4.086 MHz	BEL4.086	Referenced to 4.286 MHz. For reference only. EQU = off. Input a 20 mV p-p, f = 4.286 MHz CW signal to pin 14 and, measure the pin 16 output (f = 4.286 MHz). Next, input a CW of 20 mV p-p, f = 4.086 MHz and measure the pin 16 output (f = 4.086 MHz) and calculate the frequency characteristics.	-9	-6	-3	dB
Bell filter frequency characteristics 4.486 MHz	BEL4.486	Referenced to 4.286 MHz. For reference only. EQU = off. Input a 20 mV p-p, f = 4.286 MHz CW signal to pin 14 and, measure the pin 16 output (f = 4.286 MHz). Next, input a CW of 20 mV p-p, f = 4.486 MHz and measure the pin 16 output (f = 4.486 MHz) and calculate the frequency characteristics.	-5	-2	-0.5	dB
EQU frequency characteristics 4.086 MHz	EQU4.086	Referenced to 4.286 MHz. For reference only. EQU = on. Input a 20 mV p-p, f = 4.286 MHz CW signal to pin 14 and, measure the pin 16 output (f = 4.286 MHz). Next, input a CW of 20 mV p-p, f = 4.086 MHz and measure the pin 16 output (f = 4.086 MHz) and calculate the frequency characteristics.	-10.5	-7.5	-4.5	dB
EQU frequency characteristics 4.486 MHz	EQU4.486	Referenced to 4.286 MHz. For reference only. EQU = on. Input a 20 mV p-p, f = 4.286 MHz CW signal to pin 14 and measure the pin 16 output (f = 4.286 MHz). Next, input a CW of 20 mV p-p, f = 4.486 MHz and measure the pin 16 output (f = 4.486 MHz) and calculate the frequency characteristics.	-3	0	+3	dB
Bell filter frequency deviation from center frequency	BELF0	Referenced to 4.35 MHz. For reference only. EQU = off. Input a 20 mV p-p CW signal to pin 14 and modify the frequency of that signal. Measure the deviation from 4.35 MHz of the frequency (the center frequency) for which the pin 16 output is maximized.	-50	0	+50	kHz
Bell filter gain difference at f0 ±500 kHz	BELdG	Referenced to 4.35 MHz. For reference only. EQU = off. Measure the gain at the BELF0 ±500 kHz, and calculate the difference.	-1	0	+1	dB
[Chrominance Block]						
Killer operating point	KILL	Let 0 dB = 200 mV p-p. Input a color bar signal to pin 14 and gradually lower the input signal level. Measure the input level at the point the pin 13 DC voltage falls below 1/2* V <sub>CC</sub> .	-42	-36	-33	dB
B-Y output amplitude	VBY	The pin 7 B-Y amplitude for a color bar signal. Let 0 dB = 200 mV p-p. Input a color bar signal (0 dB) to pin 14, and measure the B-Y amplitude at pin 7.	0.60	0.75	0.90	V <sub>p-p</sub>
R-Y output amplitude	VRY	The pin 6 R-Y amplitude for a color bar signal. Let 0 dB = 200 mV p-p. Input a color bar signal (0 dB) to pin 14, and measure the R-Y amplitude at pin 6.	0.74	0.92	1.10	V <sub>p-p</sub>
R-Y/B-Y output ratio	RATRB	VRY/VBY. Calculate the ratio of the values measured above. RATRB = VRY/VBY	1.1	1.23	1.35	
B-Y linearity	LINBY	Input a color bar signal (0 dB) to pin 14. In the pin 7 (B-Y) output waveform measure the amplitude of the blue (+230 kHz) and yellow (-230 kHz) components (A) and measure the amplitude of the blue green (+78 kHz) and red (-78 kHz) components (B). Calculate the value of LINBY from the following formula. LINBY = (A/B) × (156/460) × 100 (%)	85	100	115	%

Continued on next page.

## LA7642N

Continued from preceding page.

Parameter	Symbol	Conditions	Ratings			Unit
			min	typ	max	
R-Y linearity	LINRY	Input a color bar signal (0 dB) to pin 14. In the pin 6 (R-Y) output waveform measure the amplitude of the blue green (+280 kHz) and red (-280 kHz) components (A) and measure the amplitude of the blue (+45 kHz) and yellow (-45 kHz) components (B). Calculate the value of LINRY from the following formula. $LINRY = (A/B) \times (90/560) \times 100 (\%)$	85	100	115	%
ALC pulse height	VALC	Measure the peak value of the pin 7 ALC pulse signal. Referred to the blanking period DC level.	180	200	220	mVp-p
Blanking period B-Y DC voltage	VALC	The pin 7 blanking period DC level.	3.8	4.1	4.4	V
Blanking period R-Y DC voltage	VRVBLK	The pin 6 blanking period DC level.	3.8	4.1	4.4	V
SECAM output impedance: B-Y	ZBYS	The pin 7 output impedance. For reference only. Input a color bar signal (0 dB) to pin 14 and measure the pin 7 B-Y amplitude $V_b$ (V p-p). Next, connect a 2-k $\Omega$ resistor between pin 7 and ground and measure the pin 7 B-Y amplitude $V_{wrb}$ (V p-p). Derive ZBYS from the following formula. $ZBYS = (V_b - V_{wrb})/V_{wrb} \times 2k (\Omega)$ .		150		$\Omega$
SECAM output impedance: R-Y	ZRYS	The pin 6 output impedance. For reference only. Input a color bar signal (0 dB) to pin 14 and measure the pin 6 R-Y amplitude $V_r$ (V p-p). Next, connect a 2-k $\Omega$ resistor between pin 6 and ground and measure the pin 6 R-Y amplitude $V_{wrr}$ (V p-p). Derive ZRYS from the following formula. $ZRYS = (V_r - V_{wrr})/V_{wrr} \times 2k (\Omega)$ .		150		$\Omega$
Output impedance Non-SECAM: B-Y	ZBY	The pin 7 output impedance. For reference only. Apply a 4-V signal to pin 7 (B-Y), measure the influx current $I_b$ , and derive ZBY from the following formula. $ZBY = 4/I_b$ (M $\Omega$ )	10			M $\Omega$
Output impedance Non-SECAM: R-Y	ZRY	The pin 6 output impedance. For reference only. Apply a 4-V signal to pin 6 (R-Y), measure the influx current $I_r$ , and derive ZRY from the following formula. $ZRY = 4/I_r$ (M $\Omega$ )	10			M $\Omega$
Black level error B-Y	BBBY	The DC difference between the pin 7 no signal period DC level and the signal period DC level for a black-and-white signal. Measure DBY (V) and calculate BBBY from the following formula. $BBBY = DBY \times 460/VBY$ kHz	-5	0	+5	kHz
Black level error R-Y	BBRY	The DC difference between the pin 6 no signal period DC level and the signal period DC level for a black-and-white signal. Measure DRY (V) and calculate BBRY from the following formula. $BBRY = DRY \times 460/VRV$ kHz	-5	0	+5	kHz
[De-Emphasis Characteristics]						
De-emphasis 63k B-Y	DE63B	Input a signal to which a 63-kHz modulation has been applied to pin 14 and measure the pin 7 B-Y amplitude $V_{bon}$ (V p-p) when preemphasis is on. Next, turn off pre-emphasis, measure the pin 7 B-Y amplitude $V_{boff}$ (V p-p), and calculate DE63B from the following formula. $DE63B = 20 \times \log (V_{boff}/V_{bon})$ (dB)	-1.0	-2.6	-4.0	dB

Continued on next page.

## LA7642N

Continued from preceding page.

Parameter	Symbol	Conditions	Ratings			Unit
			min	typ	max	
De-emphasis 63k R-Y	DE63R	Input a signal to which a 63-kHz modulation has been applied to pin 14 and measure the pin 6 R-Y amplitude $V_{ron}$ (V p-p) when pre-emphasis is on. Next, turn off preemphasis, measure the pin 6 R-Y amplitude $V_{roff}$ (V p-p), and calculate DE63R from the following formula. $DE63R = 20 \times \log (V_{roff}/V_{ron})$ (dB)	-1.0	-2.6	-4.0	dB
De-emphasis 250k B-Y	DE250B	Input a signal to which a 250-kHz modulation has been applied to pin 14 and measure the pin 7 B-Y amplitude $V_{bon}$ (V p-p) when pre-emphasis is on. Next, turn off preemphasis, measure the pin 7 B-Y amplitude $V_{boff}$ (V p-p), and calculate DE250B from the following formula. $DE250B = 20 \times \log (V_{boff}/V_{bon})$ (dB)	-4.5	-7.0	-9.5	dB
De-emphasis 250k R-Y	DE250R	Input a signal to which a 250-kHz modulation has been applied to pin 14 and measure the pin 6 R-Y amplitude $V_{ron}$ (V p-p) when pre-emphasis is on. Next, turn off preemphasis, measure the pin 6 R-Y amplitude $V_{roff}$ (V p-p), and calculate DE250R from the following formula. $DE250R = 20 \times \log (V_{roff}/V_{ron})$ (dB)	-6.5	-9.0	-11.5	dB
[Sandcastle Pulse]						
V threshold voltage	VBLK	Apply at least 16 pulses with an amplitude of 0 V to $V_{CC}$ and then take the following measurement. Apply a DC voltage to pin 10 and slowly increase this voltage starting at 0 V. Measure the DC voltage applied to pin at the point the pin 3 DC voltage exceeds 3 V.	1.0	1.3	1.6	V
H threshold voltage	HBLK	Apply at least 16 pulses with an amplitude of 0 V to $V_{CC}$ and then take the following measurement. Apply a pulse signal with a 12- $\mu$ s high period and a 52- $\mu$ s low period (for a 64- $\mu$ s cycle) and slowly increase the amplitude of that signal starting at 0. Measure the wave height of that pulse signal at the point the pin 7 (B-Y) DC voltage exceeds $V_{BYBLK} + 100$ mV.	2.5	3.0	3.5	V
BGP threshold voltage	BGP	Apply at least 16 pulses with an amplitude of 0 V to $V_{CC}$ and then take the following measurement. Apply a pulse signal with a 12- $\mu$ s high period and a 52- $\mu$ s low period (for a 64- $\mu$ s cycle) and slowly increase the amplitude of that signal starting at 0. Measure the wave height of that pulse signal at the point the pin 4 (IDF) DC voltage becomes higher than it was at the point the pulse signal wave height was 0.	4.5	5.0	5.5	V
[System Switching]						
SECAM threshold voltage 1	SESWLO	Slowly increase the pin 12 DC voltage from 0 V and measure that voltage at the point the mode switches to a non-SECAM mode.	1.0	1.3	1.6	V
SECAM threshold voltage 2	SESWHI	Slowly increase the pin 12 DC voltage from 3 V and measure that voltage at the point the mode switches to SECAM mode.	3.6	3.9	4.3	V
[Killer Output: Pin 13]						
Killer on output level	VKILON	Measure the pin 13 voltage when the killer circuit is on.	0.0	0.2	0.5	V
Killer off output level	VKILOF	Measure the pin 13 voltage when the killer circuit is off.	7.3	7.8	7.8	V
[Reference Frequency Input Block]						
4.00-MHz input level variations 1	V5DS4	Measure the variation in the pin 5 DC voltage when the 4.00-MHz input level is changed from 200 mV p-p to 100 mV p-p.	-50	0	+50	mV

## LA7642N

Continued from preceding page.

Parameter	Symbol	Conditions	Ratings			Unit
			min	typ	max	
4.00-MHz input level variations 2	V5DB4	Measure the variation in the pin 5 DC voltage when the 4.00-MHz input level is changed from 200 mV p-p to 300 mV p-p.	-50	0	+50	mV
4.43-MHz input level variations 1	V3DS44	Measure the variation in the pin 3 DC voltage when the 4.43-MHz input level is changed from 200 mV p-p to 100 mV p-p.	-50	0	+50	mV
4.43-MHz input level variations 2	V3DB44	Measure the variation in the pin 3 DC voltage when the 4.43-MHz input level is changed from 200 mV p-p to 300 mV p-p.	-50	0	+50	mV
4.00-MHz input impedance	Z9	The pin 9 input impedance. For reference only (design value)		15		kΩ
4.43-MHz input impedance	Z11	The pin 11 input impedance. For reference only (design value)		15		kΩ
[V <sub>CC</sub> Dependency]						
ALC pulse wave height	dVALC	The percentage change in the ALC pulse peak value when V <sub>CC</sub> changes by 1 V. Measure the ALC pulse peak value when V <sub>CC</sub> = 9 V and record this value as VALC9. Calculate dVALC from the following formula. (VALC9 - VALC)/1.2/VALC × 100 (%)	10	15	20	%

Notes: EQU = off: Pull pin 16 to ground through a 4.7-kΩ resistor.  
 EQU = on: Leave pin 16 open.

### Block Diagram

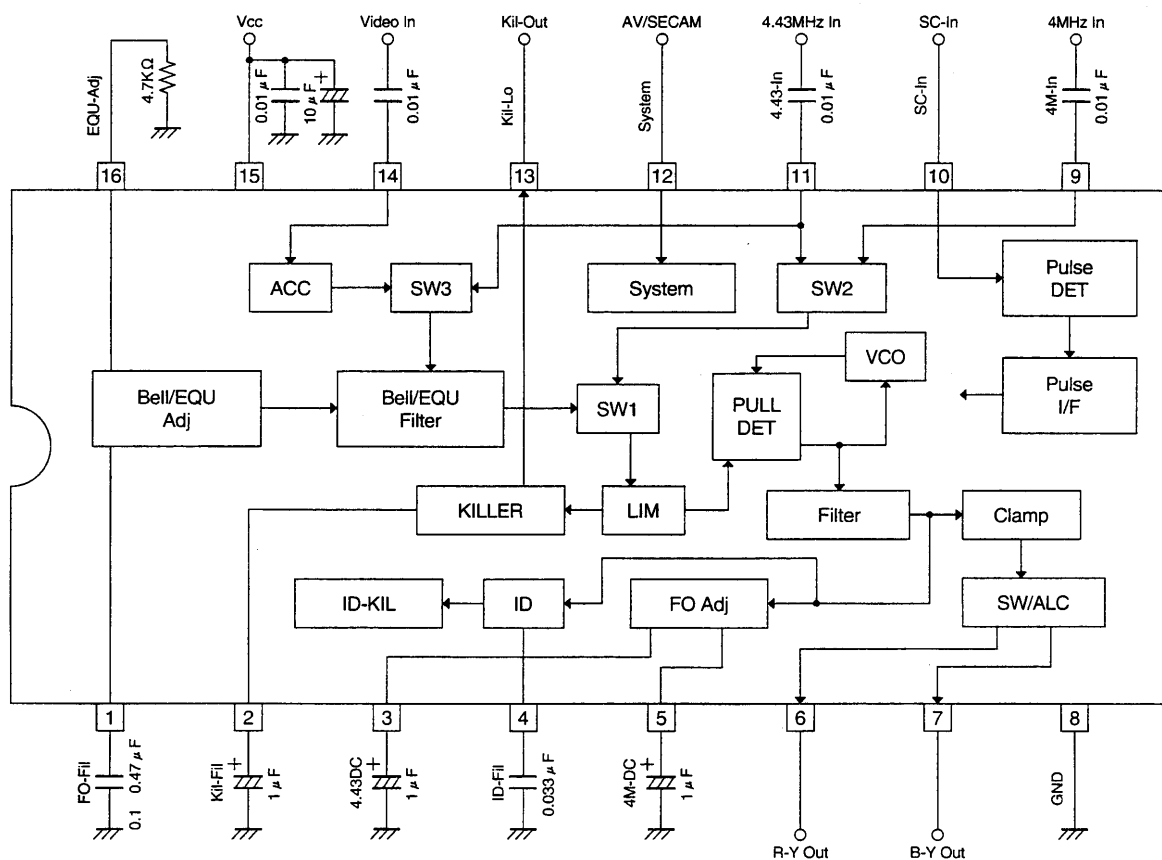

A07407

- No products described or contained herein are intended for use in surgical implants, life-support systems, aerospace equipment, nuclear power control systems, vehicles, disaster/crime-prevention equipment and the like, the failure of which may directly or indirectly cause injury, death or property loss.
- Anyone purchasing any products described or contained herein for an above-mentioned use shall:
  - ① Accept full responsibility and indemnify and defend SANYO ELECTRIC CO., LTD., its affiliates, subsidiaries and distributors and all their officers and employees, jointly and severally, against any and all claims and litigation and all damages, cost and expenses associated with such use:
  - ② Not impose any responsibility for any fault or negligence which may be cited in any such claim or litigation on SANYO ELECTRIC CO., LTD., its affiliates, subsidiaries and distributors or any of their officers and employees jointly or severally.
- Information (including circuit diagrams and circuit parameters) herein is for example only; it is not guaranteed for volume production. SANYO believes information herein is accurate and reliable, but no guarantees are made or implied regarding its use or any infringements of intellectual property rights or other rights of third parties.

This catalog provides information as of July, 1997. Specifications and information herein are subject to change without notice.