

SANYO	No. 1634G	LC7150
		FCC 10-Channel Standard PLL For Cordless Telephone

Functions

- On-chip PLL for transmission/reception
- On-chip digital unlock detector (only PLL for transmission)
- 5.0 kHz/4.4 kHz output pins for guard tone
- Standby function
- Pull-down resistance at channel select pins (D1 to D4)
LC7150: With (for mechanical switch)
LC7151: Without (for microcontroller)

Package Dimensions

unit : mm

3007A-DIP18

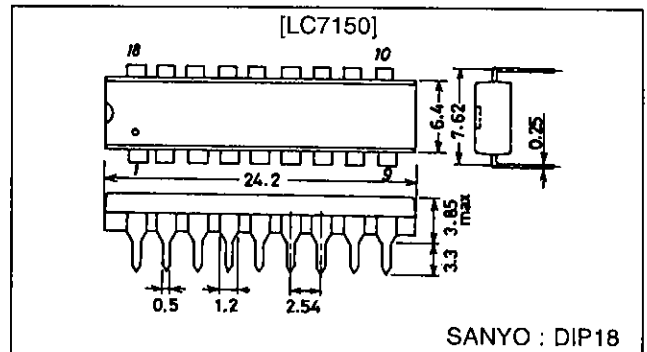

Specifications

Absolute Maximum Ratings at $T_a = 25^\circ\text{C}$, $V_{SS} = 0\text{ V}$

Parameter	Symbol	Conditions	Ratings	Unit
Maximum supply voltage	V_{DD} max		-0.3 to +6.5	V
Maximum input voltage	V_I max	All input pins	-0.3 to $V_{DD} + 0.3$	V
Maximum output voltage	V_{O1} max	$\overline{F1}, \overline{F2}$ Output OFF	-0.3 to +6.5	V
	V_{O2} max	Output pins other than V_{O1}	-0.3 to $V_{DD} + 0.3$	V
Output current	I_{OUT}	$\overline{F1}, \overline{F2}$, LDT	0 to 3.0	mA
Allowable power dissipation	P_d max	$T_a \leq 75^\circ\text{C}$	350	mW
Operating temperature	T_{opr}		-30 to +75	$^\circ\text{C}$
Storage temperature	T_{stg}		-40 to +125	$^\circ\text{C}$

Allowable Operating Conditions at $T_a = 25^\circ\text{C}$, $V_{SS} = 0\text{ V}$

Parameter	Symbol	Conditions	min	typ	max	Unit
Supply voltage	V_{DD}		3.0		5.5	V
Input high-level voltage	V_{IH1}	D1 to D4, \overline{SB}	$0.7 V_{DD}$		V_{DD}	V
Input low-level voltage	V_{IL1}	D1 to D4, \overline{SB}	0		$0.3 V_{DD}$	V
Input high-level voltage	V_{IH2}	$\overline{R/B}$	$0.9 V_{DD}$		V_{DD}	V
Input low-level voltage	V_{IL2}	$\overline{R/B}$	0		$0.1 V_{DD}$	V
Input frequency	f_{IN1}	PIT; $V_{IN} = 0.15\text{ Vrms}$	10		27	MHz
	f_{IN2}	PIR; $V_{IN} = 0.15\text{ Vrms}$	30		42	MHz
	f_{IN3}	XIN; $V_{IN} = 0.3\text{ Vrms}$	5.0	10.24	11.0	MHz
Input amplitude	V_{IN1}	PIT; $f_{IN} = 27\text{ MHz}$	0.15		$0.3 V_{DD}$	Vrms
	V_{IN2}	PIR; $f_{IN} = 42\text{ MHz}$	0.15		$0.3 V_{DD}$	Vrms
	V_{IN3}	XIN; $f_{IN} = 11\text{ MHz}$	0.3		$0.3 V_{DD}$	Vrms

LC7150

Electrical Characteristics at Ta = 25°C, under Allowable Operating Conditions

Parameter	Symbol	Conditions	min	typ	max	Unit
Input high-level current	I _{IH1}	XIN; V _I = V _{DD}			20	μA
Input low-level current	I _{IL1}	XIN; V _I = V _{SS}			20	μA
Input high-level current	I _{IH2}	PIT, PIR; V _I = V _{DD}			40	μA
Input low-level current	I _{IL2}	PIT, PIR; V _I = V _{SS}			40	μA
Input high-level current	I _{IH3}	SB, R/B; V _I = V _{DD}			10	μA
Input low-level current	I _{IL3}	SB, R/B; V _I = V _{SS}			10	μA
Input pull-down resistance	R _d	D1 to D4	10	20	40	kΩ
Input floating voltage	V _{IF}	D1 to D4; Open			0.1V _{DD}	V
Feedback resistance	R _{f1}	XIN; V _{DD} = 4.3 V		1.0		MΩ
	R _{f2}	PIT, PIR; V _{DD} = 4.3 V		0.5		MΩ
Output high-level voltage	V _{OH1}	PDT, PDR; I _O = 0.5mA	V _{DD} -1.0			V
Output low-level voltage	V _{OL1}	PDT, PDR; V _O = 0.5 mA			1.0	V
Output OFF leak current	I _{off1}	PDT,PDR; V _O = V _{DD} /V _{SS}		0.01	1.0	nA
Output high-level voltage	V _{OH2}	LDT; I _O = 1 mA	V _{DD} -1.0			V
Output OFF leak current	I _{off2}	LDT; Output OFF V _O = V _{SS}			5.0	μA
Output low-level voltage	V _{OL2}	F1,F2; I _O = 1 mA			1.0	V
Output OFF leak current	I _{off3}	F1,F2; Output OFF V _O = 5.5 V			5.0	μA
Supply current	I _{DD1}	(C3) V _{DD} = 3.0 V		4		mA
	I _{DD2}	(C3) V _{DD} = 4.5 V		7		mA
	I _{DD3}	(C3) V _{DD} = 5.5 V		13		mA
	I _{DD4}	(C2) V _{DD} = 3.0 V		3		mA
	I _{DD5}	(C2) V _{DD} = 4.5 V		5		mA
	I _{DD6}	(C2) V _{DD} = 5.5 V		10		mA

(C3): XIN = 10.24 MHz, xtal connected
 PIT = 27 MHz 150 mVrms
 PIR = 42 MHz 150 mVrms
 R/B= V_{DD}, SB = V_{DD}, Other pin open
 (C2): XIN = 10.24 MHz, xtal connected
 PIR = 42 MHz, 150 mVrms
 R/B= V_{DD}, SB = V_{SS}, Other pin open

(Note) Power supply V_{DD} - V_{SS}: Insert a capacitor of 2000 pF or greater.

Pin Assignment

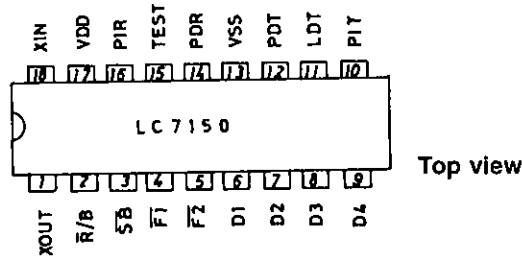

LC7150

Pin Description

Pin	Description
$\overline{F1}$	5.0 kHz output. When not used, connect to V_{SS} .
$\overline{F2}$	4.4 kHz output (10.24 MHz \div 2304). When not used, connect to V_{SS} .
V_{DD}, V_{SS}	Power supply.
XIN, XOUT	Crystal resonator (10.24 MHz).
D1 to D4	Channel select pin.
$\overline{R/B}$	Base unit/remote unit select pin. $\overline{R/B} = "0"$ (V_{SS}) Remote unit $\overline{R/B} = "1"$ (V_{DD}) Base unit
\overline{SB}	Used to stop the TX PLL at the standby mode to minimize current dissipation. $\overline{SB} = "0"$ (V_{SS}) Standby mode. Only the RX and PLL are operated. The charge pump enters a high-impedance mode. $\overline{SB} = "1"$ (V_{DD}) The TX, RX and PLL are operated.
PIT	TX programmable divider input pin.
PIR	RX programmable divider input pin.
PDT	TX charge pump output pin.
PDR	RX charge pump output pin.
TEST	LSI test input pin. Connected to V_{SS} .
LDT	TX PLL unlock signal output pin.

When the phase difference becomes $t_D (= 6.25 \mu s.)$ or more, 5.6 ms. output pulse is delivered at the LDT pin.

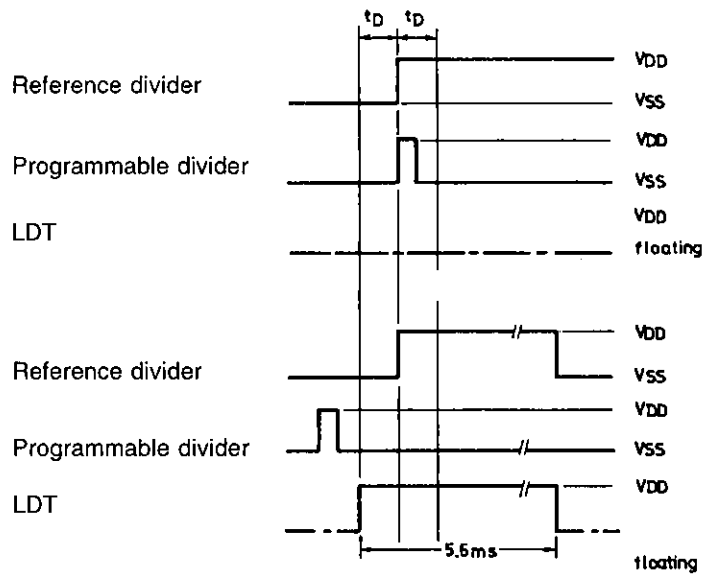

LC7150

Equivalent Circuit Block Diagram

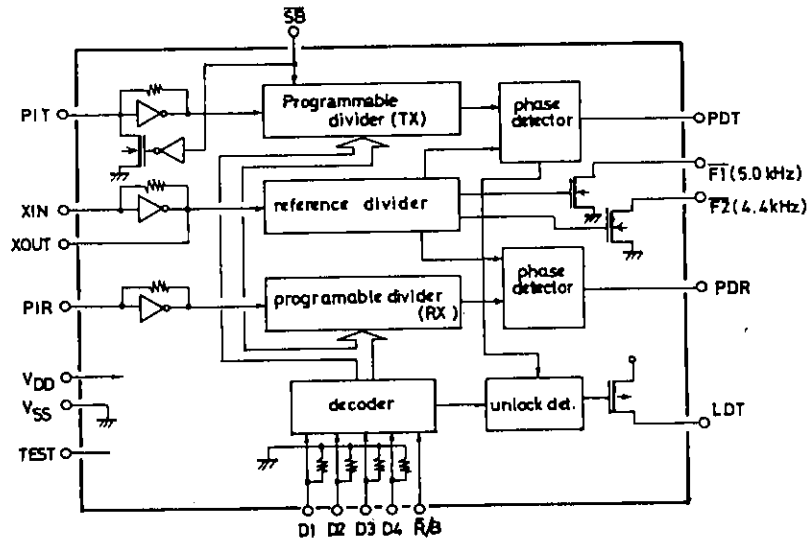

Sample Application Circuit

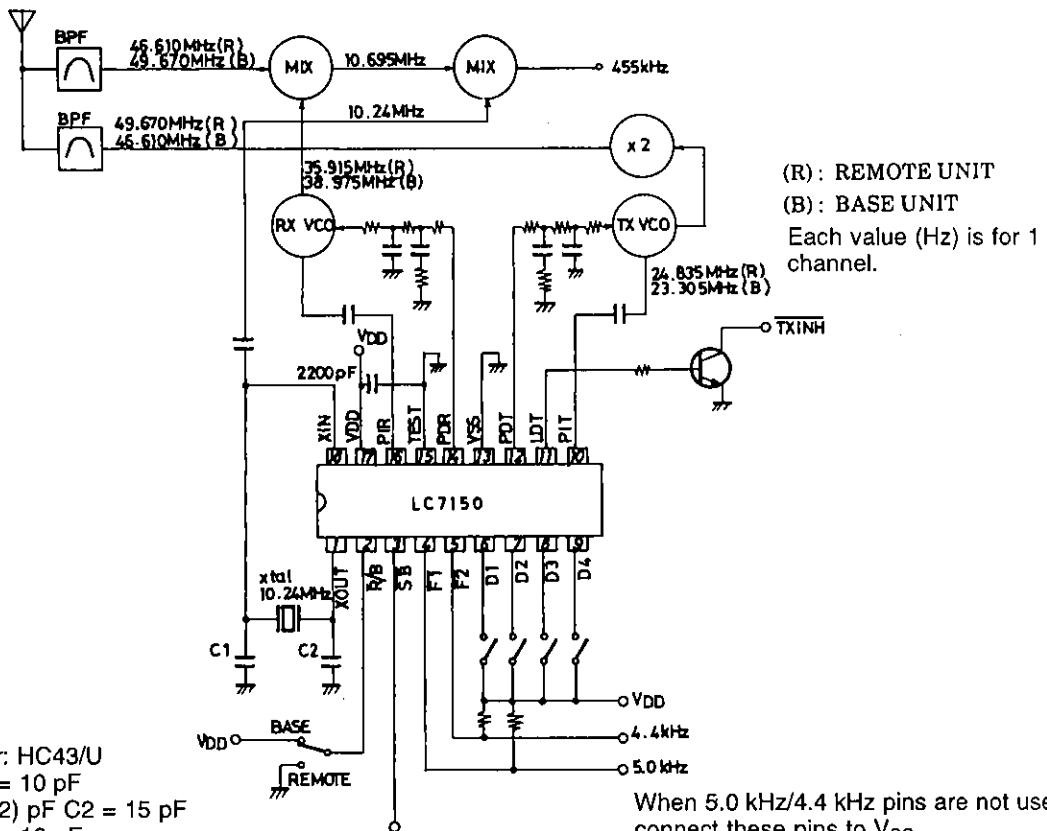

(R): REMOTE UNIT
 (B): BASE UNIT
 Each value (Hz) is for 1 channel.

Crystal resonator: HC43/U
 2114-85501: CL = 10 pF
 C1 = 15 (10 to 22) pF C2 = 15 pF
 2114-85502: CL = 16 pF
 C1 = 22 (15 to 33) pF C2 = 33 pF
 KINSEKI, LTD.

VDD: TX, RX and PLL are operated.
 VSS: Only RX and PLL are operated.

When 5.0 kHz/4.4 kHz pins are not used,
 connect these pins to VSS.

Table of Frequency Division

INPUT D1 D2 D3 D4				C H	REMOTE ($\bar{R}/B = "0"$)					BASE ($\bar{R}/B = "1"$)				
					TX (fref = 2.5 kHz)			RX (fref = 5 kHz)		TX (fref = 2.5 kHz)			RX (fref = 5 kHz)	
					f _{TX} (MHz)	f _{VCO} (MHz)	N	f _{VCO} (MHz)	N	f _{TX} (MHz)	f _{VCO} (MHz)	N	f _{VCO} (MHz)	N
1 0 0 0	1	49.670	24.8350	9934	35.915	7183	46.610	23.305	9322	38.975	7795			
0 1 0 0	2	49.845	24.9225	9969	35.935	7187	46.630	23.315	9326	39.150	7830			
1 1 0 0	3	49.860	24.9300	9972	35.975	7195	46.670	23.335	9334	39.165	7833			
0 0 1 0	4	49.770	24.8850	9954	36.015	7203	46.710	23.355	9342	39.075	7815			
1 0 1 0	5	49.875	24.9375	9975	36.035	7207	46.730	23.365	9346	39.180	7836			
0 1 1 0	6	49.830	24.9150	9966	36.075	7215	46.770	23.385	9354	39.135	7827			
1 1 1 0	7	49.890	24.9450	9978	36.135	7227	46.830	23.415	9366	39.195	7839			
0 0 0 1	8	49.930	24.9650	9986	36.175	7235	46.870	23.435	9374	39.235	7847			
1 0 0 1	9	49.990	24.9950	9998	36.235	7247	46.930	23.465	9386	39.295	7859			
0 1 0 1	10	49.970	24.9850	9994	36.275	7255	46.970	23.485	9394	39.275	7855			
1 1 0 1	10	49.970	23.9850	9994	36.275	7255	46.970	23.485	9394	39.275	7855			
0 0 1 1	10	49.970	23.9850	9994	36.275	7255	46.970	23.485	9394	39.275	7855			
1 0 1 1	10	49.970	23.9850	9994	36.275	7255	46.970	23.485	9394	39.275	7855			
0 1 1 1	10	49.970	23.9850	9994	36.275	7255	46.970	23.485	9394	39.275	7855			
1 1 1 1	10	49.970	23.9850	9994	36.275	7255	46.970	23.485	9394	39.275	7855			
0 0 0 0	10	49.970	23.9850	9994	36.275	7255	46.970	23.485	9394	39.275	7855			

■ No products described or contained herein are intended for use in surgical implants, life-support systems, aerospace equipment, nuclear power control systems, vehicles, disaster/crime-prevention equipment and the like, the failure of which may directly or indirectly cause injury, death or property loss.

■ Anyone purchasing any products described or contained herein for an above-mentioned use shall:

- ① Accept full responsibility and indemnify and defend SANYO ELECTRIC CO., LTD., its affiliates, subsidiaries and distributors and all their officers and employees, jointly and severally, against any and all claims and litigation and all damages, cost and expenses associated with such use:
- ② Not impose any responsibility for any fault or negligence which may be cited in any such claim or litigation on SANYO ELECTRIC CO., LTD., its affiliates, subsidiaries and distributors or any of their officers and employees jointly or severally.

■ Information (including circuit diagrams and circuit parameters) herein is for example only; it is not guaranteed for volume production. SANYO believes information herein is accurate and reliable, but no guarantees are made or implied regarding its use or any infringements of intellectual property rights or other rights of third parties.

This catalog provides information as of October, 1996. Specifications and information herein are subject to change without notice.