

Chip Inductor (Chip Coil) Power Inductor (Wire Wound Type for Choke)

LQH31C Series (1206 Size)

■ Dimensions

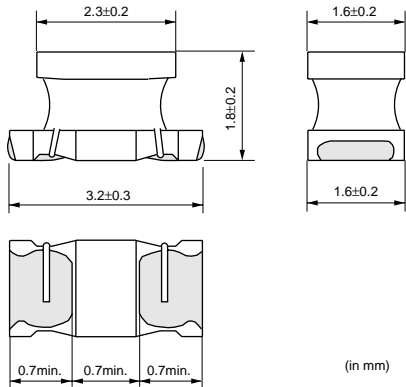

■ Packaging

Code	Packaging	Minimum Quantity
L	180mm Embossed Tape	2000
K	330mm Embossed Tape	7500

■ Rated Value (□: packaging code)

Part Number	Inductance	Test Frequency	Rated Current	DC Resistance	Self Resonance Frequency (min.)	Class of Magnetic Shield
LQH31CNR12M03□	0.12μH±20%	1MHz	970mA	0.08ohm±40%	250MHz	No magnetic shield
LQH31CNR22M03□	0.22μH±20%	1MHz	850mA	0.1ohm±40%	250MHz	No magnetic shield
LQH31CNR47M03□	0.47μH±20%	1MHz	700mA	0.15ohm±40%	180MHz	No magnetic shield
LQH31CN1R0M03□	1.0μH±20%	1MHz	510mA	0.28ohm±30%	100MHz	No magnetic shield
LQH31CN2R2M03□	2.2μH±20%	1MHz	430mA	0.41ohm±30%	50MHz	No magnetic shield
LQH31CN4R7M03□	4.7μH±20%	1MHz	340mA	0.65ohm±30%	31MHz	No magnetic shield
LQH31CN100K03□	10μH±10%	1MHz	230mA	1.3ohm±30%	20MHz	No magnetic shield
LQH31CN220K03□	22μH±10%	1MHz	160mA	3.0ohm±30%	14MHz	No magnetic shield
LQH31CN470K03□	47μH±10%	1MHz	100mA	8.0ohm±30%	10MHz	No magnetic shield
LQH31CN101K03□	100μH±10%	1MHz	80mA	12ohm±30%	7MHz	No magnetic shield

Operating Temperature Range: -40 to +85°C

Continued on the following page. 

● This data sheet is applied for CHIP INDUCTORS (CHIP COILS) used for General Electronics equipment for your design.

⚠ Note:

1. This datasheet is downloaded from the website of Murata Manufacturing co., Ltd. Therefore, it's specifications are subject to change or our products in it may be discontinued without advance notice. Please check with our sales representatives or product engineers before ordering.
2. This datasheet has only typical specifications because there is no space for detailed specifications. Therefore, please approve our product specifications or transact the approval sheet for product specifications before ordering.

 Continued from the preceding page.

■ Impedance-Frequency Characteristics (Typ.)

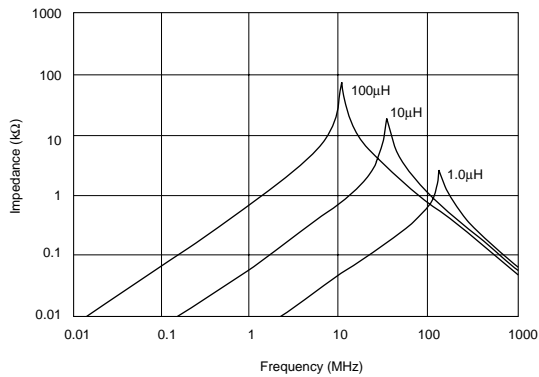

■ Inductance-Current Characteristics (Typ.)

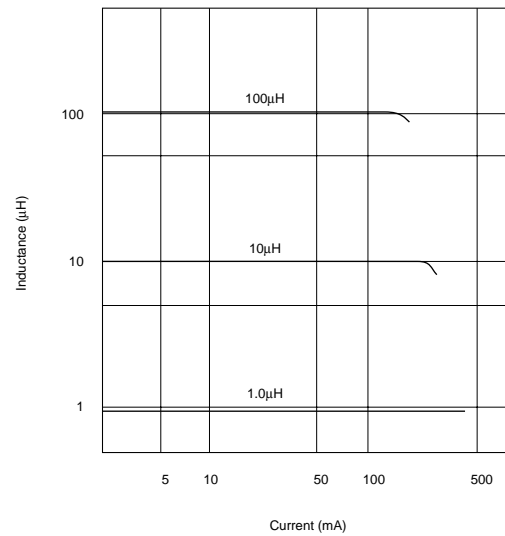

■ ⚠ Caution/Notice

⚠ Caution (Rating)

Do not use products beyond the rated current as this may create excessive heat.

Notice

Solderability of Tin plating termination chip might be deteriorated when low temperature soldering profile where peak solder temperature is below the Tin melting point is used. Please confirm the solderability of Tin plating termination chip before use.

● This data sheet is applied for CHIP INDUCTORS (CHIP COILS) used for General Electronics equipment for your design.

⚠ Note:

1. This datasheet is downloaded from the website of Murata Manufacturing co., Ltd. Therefore, it's specifications are subject to change or our products in it may be discontinued without advance notice. Please check with our sales representatives or product engineers before ordering.
2. This datasheet has only typical specifications because there is no space for detailed specifications. Therefore, please approve our product specifications or transact the approval sheet for product specifications before ordering.