

ELECTRONIC TWO - TONE RINGER

- LOW CURRENT CONSUMPTION, IN ORDER TO ALLOW THE PARALLEL OPERATION OF 4 DEVICES
- INTEGRATED RECTIFIER BRIDGE WITH ZENER DIODES TO PROTECT AGAINST OVERVOLTAGES
- LITTLE EXTERNAL CIRCUITRY
- TONE AND SWITCHING FREQUENCIES ADJUSTABLE BY EXTERNAL COMPONENTS
- INTEGRATED VOLTAGE AND CURRENT HYSTERESIS

DESCRIPTION

LS1240 and LS1240A are monolithic integrated circuits designed to replace the mechanical bell in telephone sets in connection with an electro-acoustical converter. Both devices can drive directly a piezo-ceramic converter (buzzer).

The output current capability of LS1240A is higher than LS1240. For driving a dynamic loudspeaker LS1240 needs a transformer, while LS1240A, needs a decoupling capacitor.

No current limitation is provided on the output stage of LS1240A, so a minimum load DC of 50 Ω is advised.

The two tone frequencies generated are switched by an internal oscillator in a fast sequence and made audible across an output amplifier in the loudspeaker, both tone frequencies and the switching frequency can be externally adjusted.

PIN CONNECTION (top view)

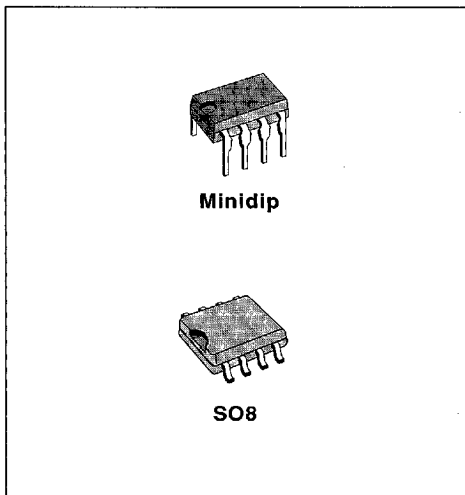
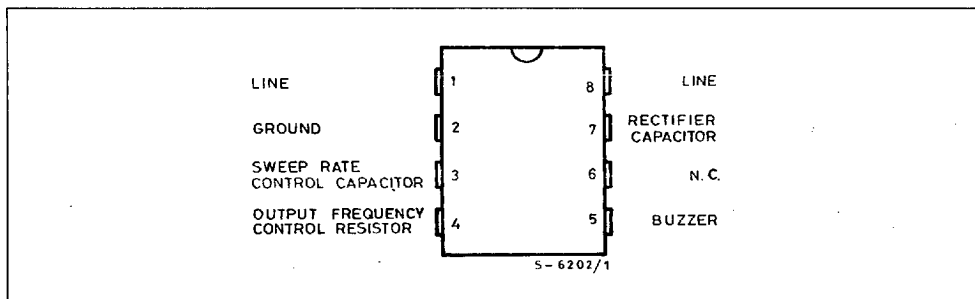

ORDERING NUMBERS

Minidip	SO8
LS1240	-
LS1240A	LS1240AD1

The supply voltage is obtained from the AC ring signal and the circuit is designed so that noise on the line or variations of the ringing signal cannot affect correct operation of the device.

BLOCK DIAGRAM

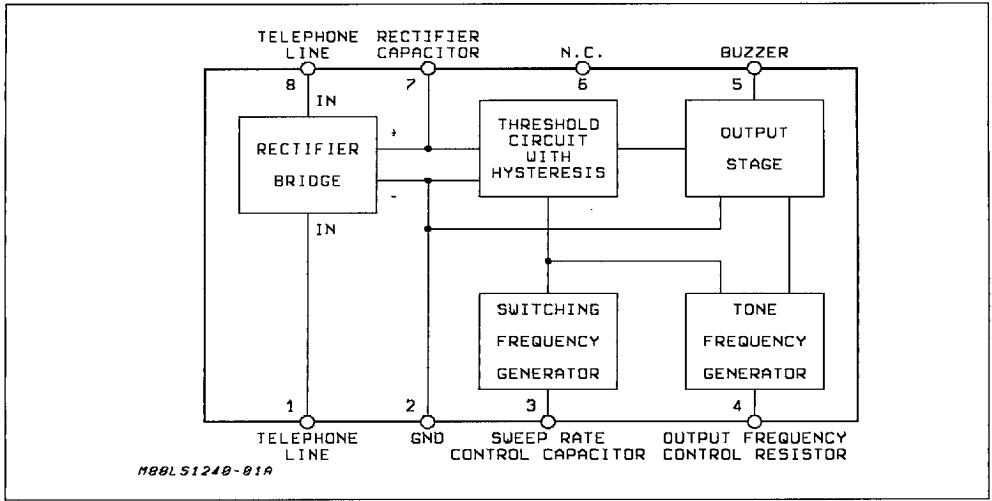
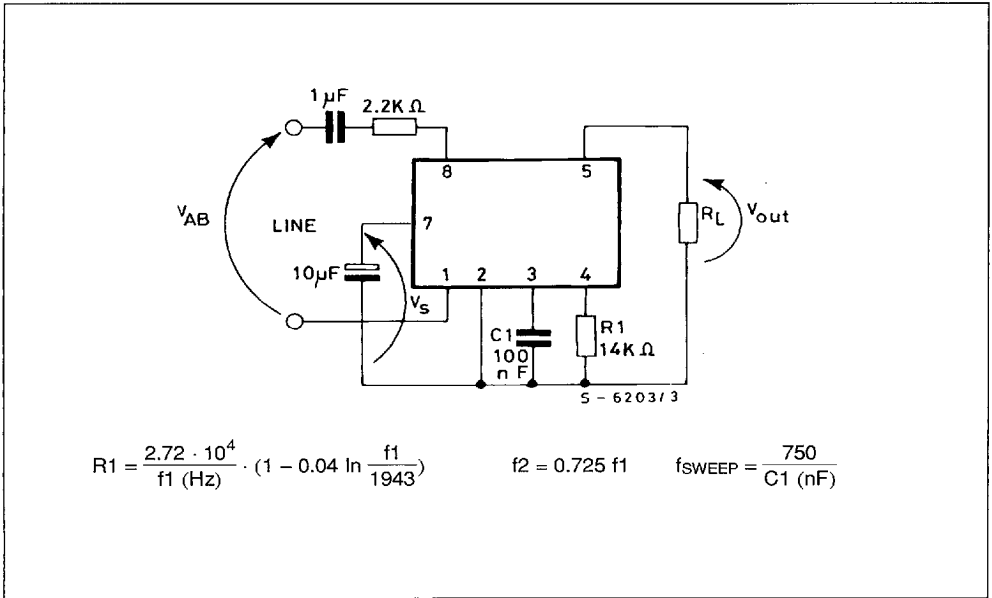

Figure 1 : Test Circuit.



ABSOLUTE MAXIMUM RATINGS

Symbol	Parameter	Value	Unit
V _{AB}	Calling Voltage (f = 50 Hz) Continuous	120	V _{rms}
V _{AB}	Calling Voltage (f = 50 Hz) 5s ON/10s OFF	200	V _{rms}
DC	Supply Current	30	mA
T _{op}	Operating Temperature	- 20 to + 70	°C
T _{stg}	Storage and Junction Temperature	- 65 to + 150	°C

THERMAL DATA

Symbol	Parameter	Value	Unit
R _{th j-amb}	Thermal Resistance Junction-ambient	Max 100	°C/W

ELECTRICAL CHARACTERISTICS

(T_{amb} = 25 °C; V_s = applied between pins 7-2 unless otherwise specified)

Symbol	Parameter	Test Conditions	Min.	Typ.	Max.	Unit
V _s	Supply Voltage				26	V
I _B	Current Consumption without Load (pins 8-1)	V _{B-1} = 9.3 to 25 V		1.5	1.8	mA
V _{ON}	Activation Voltage	LS1240 LS1240A	12.2 12		13.2 13.5	V V
V _{OFF}	Sustaining Voltage	LS1240 LS1240A	8 7.8		9 9.3	V V
R _D	Differential Resistance in OFF Condition (pins 8-1)		6.4			kΩ
V _{OUT}	Output Voltage Swing			V _s - 5		V
I _{OUT}	Short Circuit Current (pins 5-2)	LS1240 LS1240A	V _s = 20V R _L = 0Ω R _L = 250Ω		35 70	mA mA

AC OPERATION

f ₁ f ₂	Output Frequencies f _{out1} f _{out2}	V _s = 26V, R ₁ = 14kΩ V _s = 0 V V _s = 6V	1.74 1.22		2.14 1.6	kHz
	f _{OUT1} f _{OUT2}		1.33		1.43	
	Programming Resistor Range		8		56	kΩ
f _{SWEEP}	Sweep Frequency	R ₁ = 14kΩ, C ₁ = 100nF	5.25	7.5	9.75	Hz

7929237 0053474 422

Figure 2 : Typical Application for LS1240 and LS1240A

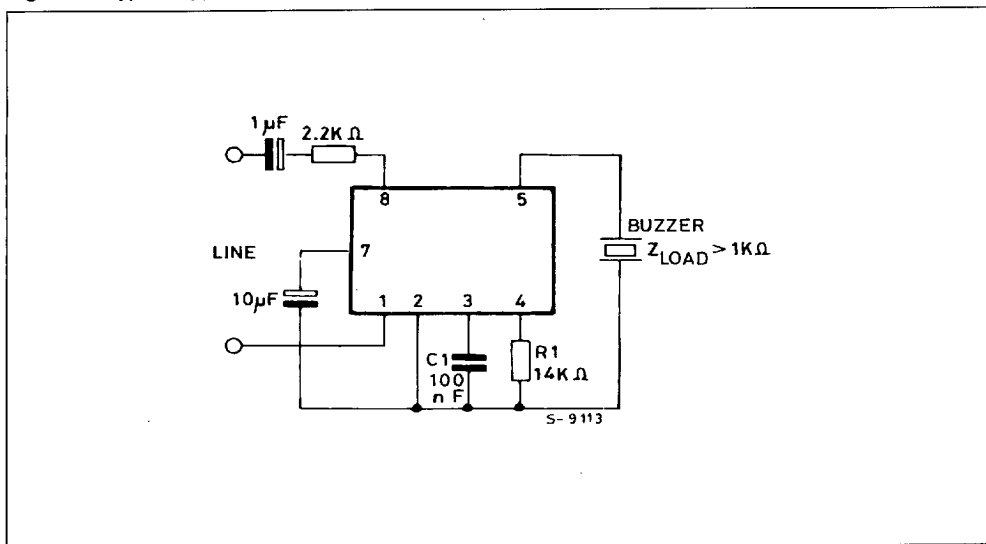

Figure 3 : Typical Application for LS1240A only.

