

## FEATURES

- Complete Step-Down Switch Mode Power Supply
- Wide Input Voltage Range: 3.6V to 36V
- 2A Output Current
- 0.8V to 10V Output Voltage
- Selectable Switching Frequency: 200kHz to 2.4MHz
- Current Mode Control
- Pb-Free (e4) RoHS Compliant Package with Gold Pad Finish
- Programmable Soft-Start
- Tiny, Low Profile (11.25mm × 9mm × 2.82mm) Surface Mount LGA Package

## APPLICATIONS

- Automotive Battery Regulation
- Power for Portable Products
- Distributed Supply Regulation
- Industrial Supplies
- Wall Transformer Regulation

## DESCRIPTION

The LTM<sup>®</sup>8023 is a complete 2A, DC/DC step-down power supply. Included in the package are the switching controller, power switches, inductor, and all support components. Operating over an input voltage range of 3.6V to 36V, the LTM8023 supports an output voltage range of 0.8V to 10V, and a switching frequency range of 200kHz to 2.4MHz, each set by a single resistor. Only the bulk input and output filter capacitors are needed to finish the design.

The low profile package (2.82mm) enables utilization of unused space on the bottom of PC boards for high density point of load regulation.

The LTM8023 is packaged in a thermally enhanced, compact (11.25mm × 9mm) and low profile (2.82mm) over-molded Land Grid Array (LGA) package suitable for automated assembly by standard surface mount equipment. The LTM8023 is Pb-free and RoHS compliant.

**LT**, **LT**, **LTC** and **LTM** are registered trademarks of Linear Technology Corporation. All other trademarks are the property of their respective owners.

## TYPICAL APPLICATION

5.5V<sub>IN</sub> to 36V<sub>IN</sub>, 3.3V/2A DC/DC μModule Converter

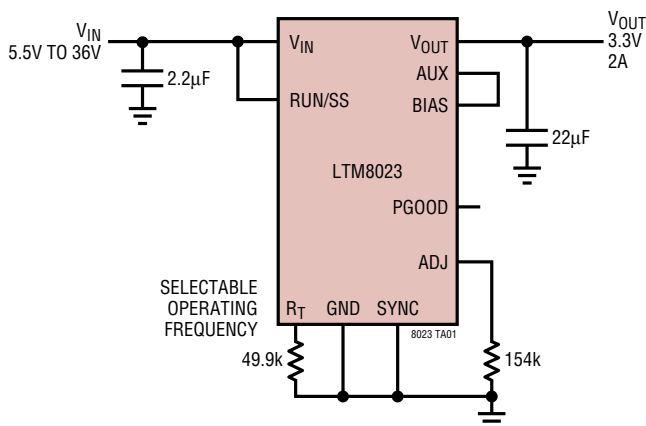

Efficiency and Power Loss

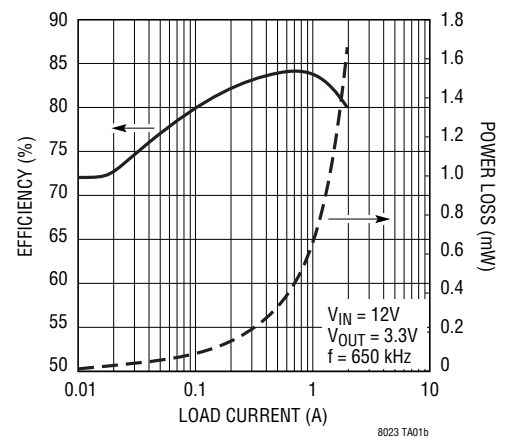

# LTM8023

## ABSOLUTE MAXIMUM RATINGS

(Note 1)

$V_{IN}$ , RUN/SS Voltage .....	40V
ADJ, $R_T$ , SHARE Voltage .....	5V
$V_{OUT}$ , AUX .....	10V
PGOOD, SYNC .....	30V
BIAS .....	16V
$V_{IN}$ + BIAS .....	56V
Maximum Junction Temperature (Note 2) .....	125°C
Solder Temperature .....	240°C

## PIN CONFIGURATION

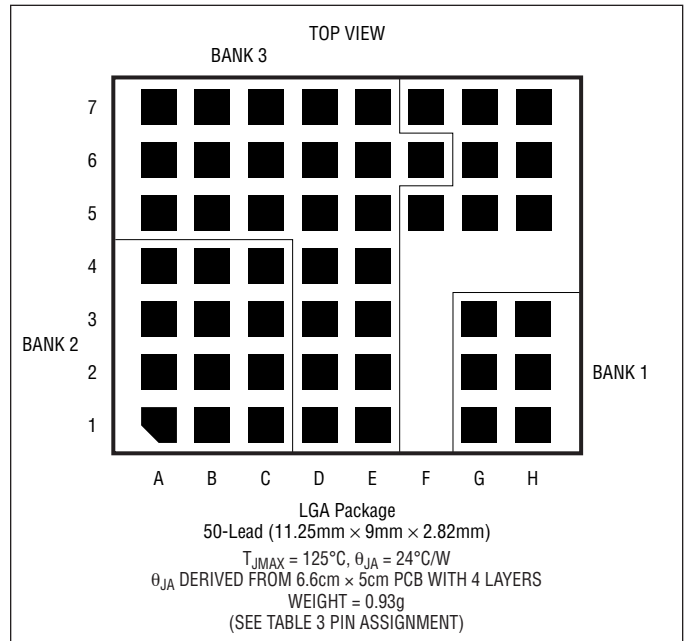

## ORDER INFORMATION

LEAD FREE FINISH	PART MARKING	PACKAGE DESCRIPTION	JUNCTION TEMPERATURE RANGE
LTM8023EV#PBF	LTM8023V	50-Lead (11.25mm × 9mm × 2.82mm)	-40°C to 125°C

Consult LTC Marketing for parts specified with wider operating temperature ranges.

For more information on lead free part marking, go to: <http://www.linear.com/leadfree/>

This product is only offered in trays. For more information go to: <http://www.linear.com/packaging/>

## ELECTRICAL CHARACTERISTICS

The ● denotes the specifications which apply over the full operating temperature range, otherwise specifications are at  $T_A = 25^\circ\text{C}$ .  $V_{IN} = 10\text{V}$ ,  $V_{RUN/SS} = 10\text{V}$ ,  $V_{BIAS} = 3\text{V}$ ,  $R_T = 60.4\text{k}$ ,  $C_{OUT} = 4.7\mu\text{F}$  unless otherwise specified.

SYMBOL	PARAMETER	CONDITIONS	MIN	TYP	MAX	UNITS
$V_{IN}$	Input DC Voltage		●	3.6	36	V
$V_{OUT}$	Output DC Voltage	$0 < I_{OUT} \leq 2\text{A}$ , $43.2\text{k}\Omega < R_{ADJ} < \infty$ , $C_{OUT} = 51\mu\text{F}$ (Note 3)		0.8	10	V
$R_{ADJ(MIN)}$	Minimum Allowable $R_{ADJ}$			42.2		$\text{k}\Omega$
$I_{OUT}$	Continuous Output DC Current	$4 \leq V_{IN} \leq 36$ , $C_{OUT} = 51\mu\text{F}$		0	2	A
$I_{QVIN}$	$V_{IN}$ Quiescent Current	$V_{RUN/SS} = 0.2\text{V}$ , $R_T = 174\text{k}$ $V_{BIAS} = 3\text{V}$ , Not Switching, $R_T = 174\text{k}$ $V_{BIAS} = 0\text{V}$ , Not Switching, $R_T = 174\text{k}$	●	0.1 25 85	0.5 60 120	$\mu\text{A}$ $\mu\text{A}$ $\mu\text{A}$
$I_{QBIAS}$	BIAS Quiescent Current	$V_{RUN/SS} = 0.2\text{V}$ , $R_T = 174\text{k}$ $V_{BIAS} = 3\text{V}$ , Not Switching, $R_T = 174\text{k}$ $V_{BIAS} = 0\text{V}$ , Not Switching, $R_T = 174\text{k}$	●	0.03 50 1	0.5 120 5	$\mu\text{A}$ $\mu\text{A}$ $\mu\text{A}$
$\Delta V_{OUT}/V_{OUT}$	Line Regulation	$5 \leq V_{IN} \leq 36$ , $I_{OUT} = 1\text{A}$ , $V_{OUT} = 3.3\text{V}$ , $C_{OUT} = 51\mu\text{F}$		0.1		%
$\Delta V_{OUT}/V_{OUT}$	Load Regulation	$V_{IN} = 24\text{V}$ , $0 \leq I_{OUT} \leq 2\text{A}$ , $V_{OUT} = 3.3\text{V}$ , $C_{OUT} = 51\mu\text{F}$		0.4		%
$V_{OUT(AC\_RMS)}$	Output Ripple (RMS)	$V_{IN} = 24\text{V}$ , $I_{OUT} = 2\text{A}$ , $V_{OUT} = 3.3\text{V}$ , $C_{OUT} = 51\mu\text{F}$		10		mV
$f_{SW}$	Switching Frequency	$R_T = 113\text{k}$ , $C_{OUT} = 51\mu\text{F}$		325		kHz
$I_{SC(OUT)}$	Output Short Circuit Current	$V_{IN} = 36\text{V}$ , $V_{OUT} = 0\text{V}$		2.9		A
$V_{ADJ}$	Voltage at ADJ Pin	$C_{OUT} = 51\mu\text{F}$	●	765	790 805	mV
$V_{BIAS(MIN)}$	Minimum BIAS Voltage for Proper Operation			2.3	2.8	V
$I_{ADJ}$	Current Out of ADJ Pin	$ADJ = 1\text{V}$ , $C_{OUT} = 51\mu\text{F}$		2		$\mu\text{A}$
$I_{RUN/SS}$	RUN/SS Pin Current	$V_{RUN/SS} = 2.5\text{V}$		5	10	$\mu\text{A}$
$V_{IH(RUN/SS)}$	RUN/SS Input High Voltage	$C_{OUT} = 51\mu\text{F}$		2.5		V
$V_{IL(RUN/SS)}$	RUN/SS Input Low Voltage	$C_{OUT} = 51\mu\text{F}$			0.2	V
$V_{PG(TH)}$	PG Threshold	$V_{OUT}$ Rising		730		mV
$I_{PGO}$	PG Leakage	$V_{PG} = 30\text{V}$		0.1	1	$\mu\text{A}$
$I_{PGSINK}$	PG Sink Current	$V_{PG} = 0.4\text{V}$		200	800	$\mu\text{A}$
$V_{SYNCIL}$	SYNC Input Low Threshold	$f_{SYNC} = 550\text{kHz}$ , $C_{OUT} = 51\mu\text{F}$		0.5		V
$V_{SYNCH}$	SYNC Input High Threshold	$f_{SYNC} = 550\text{kHz}$ , $C_{OUT} = 51\mu\text{F}$			0.7	V
$I_{SYNCBIAS}$	SYNC Pin Bias Current	$V_{SYNC} = 0\text{V}$		0.1		$\mu\text{A}$

**Note 1:** Stresses beyond those listed under Absolute Maximum Ratings may cause permanent damage to the device. Exposure to any Absolute Maximum Rating condition for extended periods may affect device reliability and lifetime.

**Note 2:** The LTM8023E is guaranteed to meet performance specifications from  $0^\circ\text{C}$  to  $85^\circ\text{C}$ . Specifications over the  $-40^\circ\text{C}$  to  $85^\circ\text{C}$  operating temperature range are assured by design, characterization and correlation with statistical process controls.

**Note 3:**  $C_{OUT} = 51\mu\text{F}$  is composed of a  $4.7\mu\text{F}$  ceramic capacitor in parallel with a  $47\mu\text{F}$  electrolytic.

## TYPICAL PERFORMANCE CHARACTERISTICS $T_A = 25^\circ\text{C}$ unless otherwise noted

### Efficiency (8V<sub>OUT</sub>)

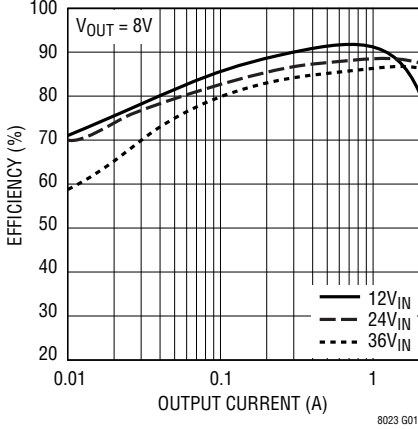

### Efficiency (5V<sub>OUT</sub>)

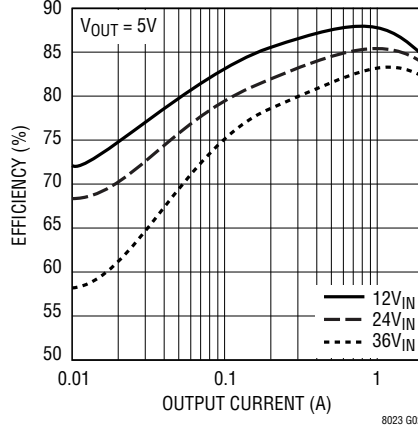

### Efficiency (3.3V<sub>OUT</sub>)

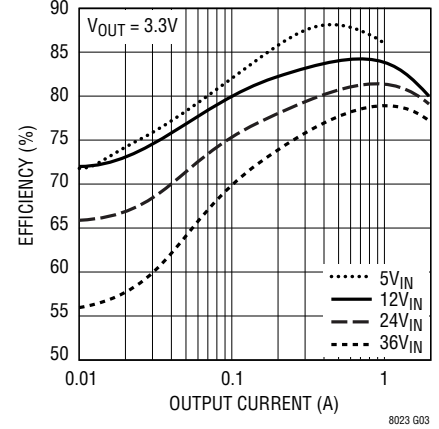

### Minimum Required Input Voltage vs Output Voltage

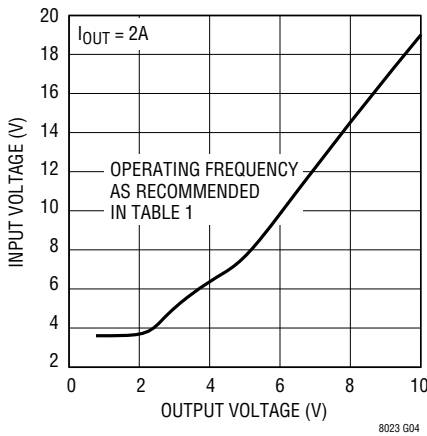

### 36V<sub>IN</sub> Start-Up Waveforms (5V<sub>OUT</sub>)

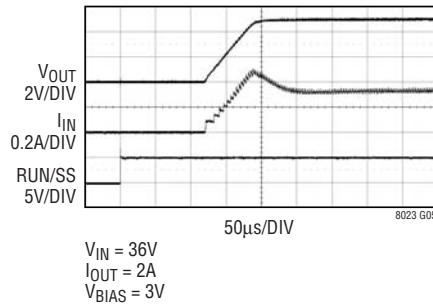

### 36V<sub>IN</sub> Start-Up Waveforms (3.3V<sub>OUT</sub>)

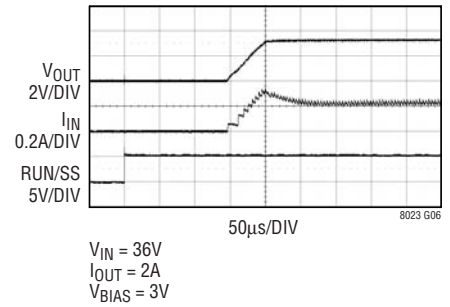

### Input Current vs Output Current

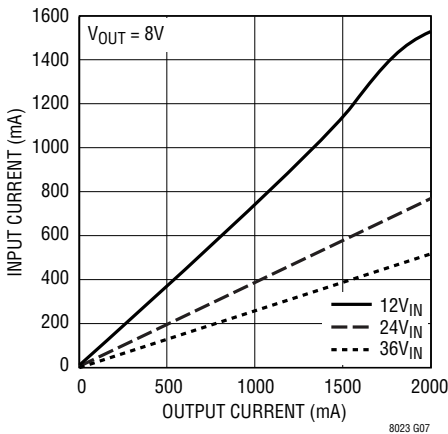

### Input Current vs Output Current

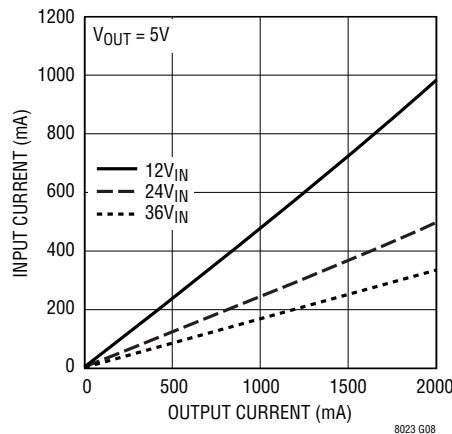

### Input Current vs Output Current

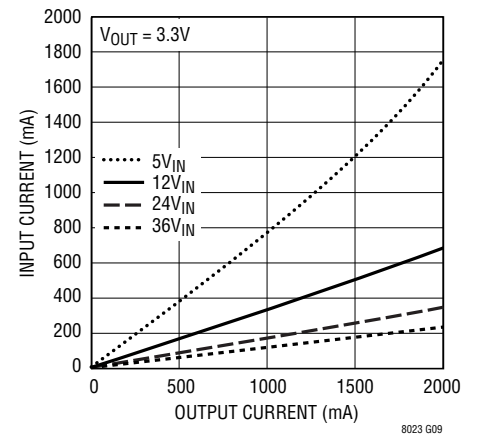

**TYPICAL PERFORMANCE CHARACTERISTICS**  $T_A = 25^\circ\text{C}$  unless otherwise noted

**Output Short-Circuit Current vs Input Voltage**

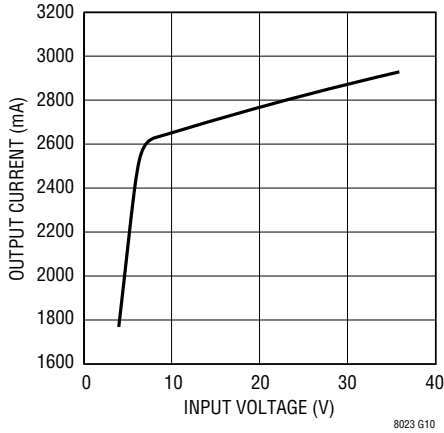

**BIAS Current vs Load Current**

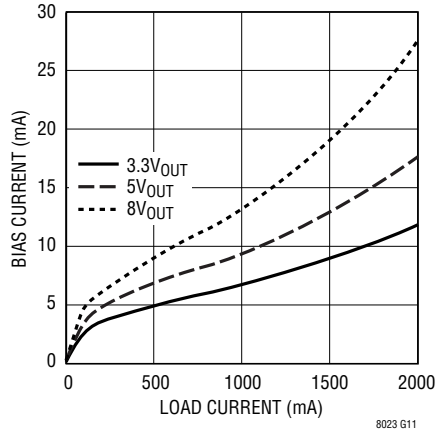

**Maximum Load Current vs Input Voltage (8V<sub>OUT</sub>)**

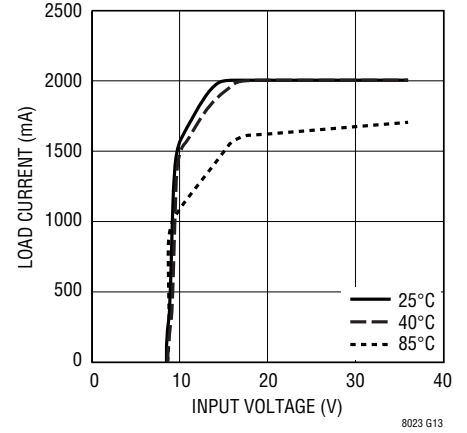

**Load Current vs Input Voltage (5V<sub>OUT</sub>)**

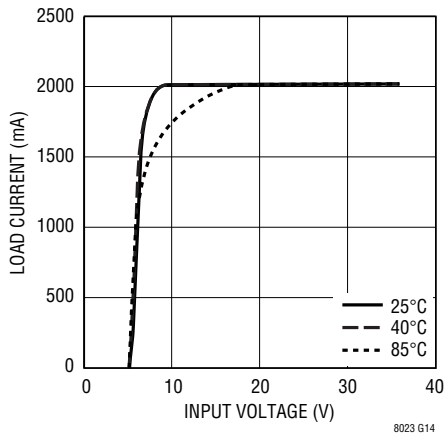

**Load Current vs Input Voltage (3.3V<sub>OUT</sub>)**

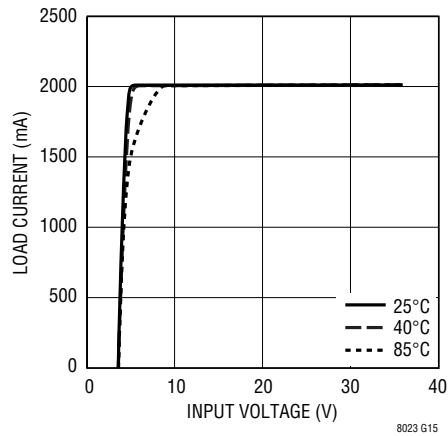

## PIN FUNCTIONS

**V<sub>IN</sub> (Bank 1):** The V<sub>IN</sub> pin supplies current to the LTM8023's internal regulator and to the internal power switch. This pin must be locally bypassed with an external, low ESR capacitor of at least 2.2μF.

**V<sub>OUT</sub> (Bank 2):** Power Output Pins. Apply the output filter capacitor and the output load between these pins and GND pins.

**AUX (Pin F5):** Low current voltage source for BIAS. In many designs, the BIAS pin is simply connected to V<sub>OUT</sub>. The V<sub>AUX</sub> pin is internally connected to V<sub>OUT</sub> and is placed adjacent to the BIAS pin to ease printed circuit board routing. Although this pin is internally connected to V<sub>OUT</sub>, do NOT connect this pin to the load. If this pin is not tied to BIAS, leave it floating.

**BIAS (Pin G5):** The BIAS pin connects to the internal power bus. Connect to a power source greater than 2.8V. If the output is greater than 2.8V, connect this pin there. If the output voltage is less, connect this to a voltage source between 2.8V and 16V. Also, make sure that BIAS + V<sub>IN</sub> is less than 56V.

**RUN/SS (Pin H5):** Tie RUN/SS pin to ground to shut down the LTM8023. Tie to 2.5V or more for normal operation. If the shutdown feature is not used, tie this pin to the V<sub>IN</sub> pin. RUN/SS also provides a soft-start function; see the Applications Information section.

**GND (Bank 3):** Tie these GND pins to a local ground plane below the LTM8023 and the circuit components. Return the feedback divider (R<sub>ADJ</sub>) to this net.

**R<sub>T</sub> (Pin G7):** The R<sub>T</sub> pin is used to program the switching frequency of the LTM8023 by connecting a resistor from this pin to ground. The Applications Information section of the data sheet includes a table to determine the resistance value based on the desired switching frequency. Minimize capacitance at this pin.

**SHARE (Pin F7):** Tie this to the SHARE pin of another LTM8023 when paralleling the outputs. Otherwise, do not connect.

**SYNC (Pin G6):** This is the external clock synchronization input. Ground this pin for low ripple Burst Mode operation at low output loads. Tie to a stable voltage source greater than 0.7V to disable Burst Mode operation. *Do not leave this pin floating.* Tie to a clock source for synchronization. Clock edges should have rise and fall times faster than 1μs. See synchronizing section in Applications Information.

**PGOOD (Pin H6):** The PGOOD pin is the open collector output of an internal comparator. PG remains low until the ADJ pin is within 10% of the final regulation voltage. PG output is valid when V<sub>IN</sub> is above 3.6V and RUN/SS is high. If this function is not used, leave this pin floating.

**ADJ (Pin H7):** The LTM8023 regulates its ADJ pin to 0.79V. Connect the adjust resistor from this pin to ground. The value of R<sub>ADJ</sub> is given by the equation  $R_{ADJ} = 394.21 / (V_{OUT} - 0.79)$ , where R<sub>ADJ</sub> is in k.

**BLOCK DIAGRAM**

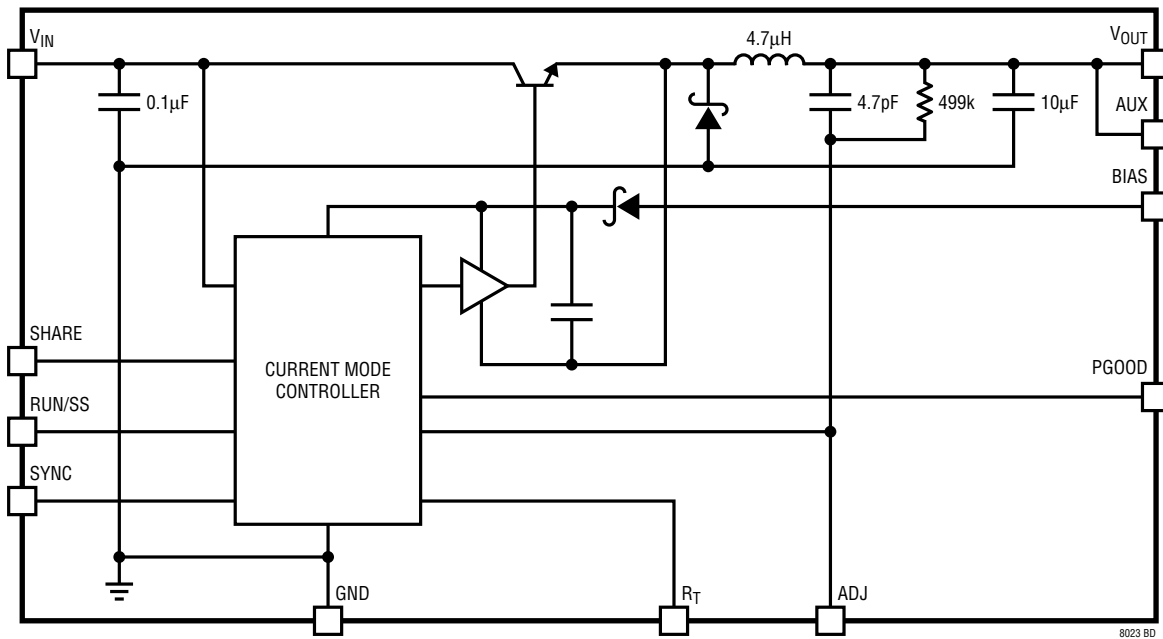

# LTM8023

---

## OPERATION

The LTM8023 is a stand-alone non-isolated step down switching DC/DC power supply. It can deliver up to 2A of DC output current with only bulk external input and output capacitors. This module provides a precisely regulated output voltage programmable via one external resistor from  $0.8V_{DC}$  to  $10V_{DC}$ . The input voltage range is 3.6V to 36V. Given that the LTM8023 is a step down converter, make sure that the input voltage is high enough to support the desired output voltage and load current. A simplified block diagram is given above.

The LTM8023 contains a current mode controller, power switching element, power inductor, power Schottky diode and a modest amount of input and output capacitance.

The LTM8023 is a fixed frequency PWM regulator. The switching frequency is set by simply connecting the appropriate resistor value from the  $R_T$  pin to GND.

An internal regulator provides power to the control circuitry. The bias regulator normally draws power from the  $V_{IN}$  pin, but if the BIAS pin is connected to an external volt-

age higher than 2.8V, bias power will be drawn from the external source (typically the regulated output voltage). This improves efficiency. The RUN/SS pin is used to place the LTM8023 in shutdown, disconnecting the output and reducing the input current to less than  $1\mu A$ .

To further optimize efficiency, the LTM8023 automatically switches to Burst Mode operation in light load situations. Between bursts, all circuitry associated with controlling the output switch is shut down reducing the input supply current to  $50\mu A$  in a typical application. The oscillator reduces the LTM8023's operating frequency when the voltage at the ADJ pin is low. This frequency foldback helps to control the output current during startup and overload.

The LTM8023 contains a power good comparator which trips when the ADJ pin is at 92% of its regulated value. The PG output is an open-collector transistor that is off when the output is in regulation, allowing an external resistor to pull the PG pin high. Power good is valid when the LTM8023 is enabled and  $V_{IN}$  is above 3.6V.

---

## APPLICATIONS INFORMATION

For most applications, the design process is straight forward, summarized as follows:

1. Look at Table 1 and find the row that has the desired input range and output voltage.
2. Apply the recommended  $C_{IN}$ ,  $C_{OUT}$ ,  $R_{ADJ}$  and  $R_T$  values.
3. Connect BIAS as indicated.

While these component combinations have been tested for proper operation, it is incumbent upon the user to verify proper operation over the intended system's line, load and environmental conditions.

### Capacitor Selection Considerations

The  $C_{IN}$  and  $C_{OUT}$  capacitor values in Table 1 are the minimum recommended values for the associated operating conditions. Applying capacitor values below those indicated in Table 1 is not recommended, and may result

in undesirable operation. Using larger values is generally acceptable, and can yield improved dynamic response, if it is necessary. Again, it is incumbent upon the user to verify proper operation over the intended system's line, load and environmental conditions.

Ceramic capacitors are small, robust and have very low ESR. However, not all ceramic capacitors are suitable. X5R and X7R types are stable over temperature and applied voltage and give dependable service. Other types, including Y5V and Z5U have very large temperature and voltage coefficients of capacitance. In an application circuit they may have only a small fraction of their nominal capacitance resulting in much higher output voltage ripple than expected.

Ceramic capacitors are also piezoelectric. In Burst Mode operation, the LTM8023's switching frequency depends on the load current, and can excite a ceramic capacitor



## APPLICATIONS INFORMATION

**Table 1. Recommended Component Values and Configuration (T<sub>A</sub> = 25°C, I<sub>OUT</sub> = 2A)**

V <sub>IN</sub>	V <sub>OUT</sub>	C <sub>IN</sub>	C <sub>OUT</sub>	R <sub>ADJ</sub>	BIAS	f <sub>OPTIMAL</sub> (kHz)	R <sub>T(OPTIMAL)</sub>	f <sub>MAX</sub> (kHz)	R <sub>T(MIN)</sub>
3.6V to 36V	0.82V	10μF	200μF 1206	13M	≥2.8V, <16V	250	150k	250	150k
3.6V to 36V	1.00V	10μF	147μF 1206	1.87M	≥2.8V, <16V	300	124k	300	124k
3.6V to 36V	1.20V	10μF	100μF 1206	953k	≥2.8V, <16V	350	105k	350	105k
3.6V to 36V	1.50V	10μF	100μF 1206	549k	≥2.8V, <16V	400	88.7k	400	88.7k
3.6V to 36V	1.80V	4.7μF	100μF 1206	383k	≥2.8V, <16V	450	79k	450	79k
3.6V to 36V	2.00V	2.2μF	68μF 1206	324k	≥2.8V, <16V	450	79k	500	69.8k
3.6V to 36V	2.20V	2.2μF	47μF 1206	274k	≥2.8V, <16V	500	69.8k	550	61.9k
4.1V to 36V	2.50V	2.2μF	47μF 1206	226k	≥2.8V, <16V	550	61.9k	615	54.9k
5.5V to 36V	3.30V	2.2μF	22μF 1206	154k	AUX	650	49.9k	750	42.2k
7.5V to 36V	5.00V	2.2μF	4.7μF 0805	93.1k	AUX	650	49.9k	890	34.8k
3.6V to 15V	0.82V	10μF	200μF 1206	13M	V <sub>IN</sub>	350	105k	650	49.9k
3.6V to 15V	1.00V	10μF	147μF 1206	1.87M	V <sub>IN</sub>	400	88.7k	725	43.2k
3.6V to 15V	1.20V	10μF	100μF 1206	953k	V <sub>IN</sub>	450	79k	800	39.2k
3.6V to 15V	1.50V	10μF	100μF 1206	549k	V <sub>IN</sub>	450	79k	1000	29.4k
3.6V to 15V	1.80V	4.7μF	100μF 1206	383k	V <sub>IN</sub>	450	79k	1100	26.7k
3.6V to 15V	2.00V	2.2μF	68μF 1206	324k	V <sub>IN</sub>	450	79k	1200	23.7k
3.6V to 15V	2.20V	2.2μF	47μF 1206	274k	V <sub>IN</sub>	500	69.8k	1300	21.0k
3.6V to 15V	2.50V	2.2μF	47μF 1206	226k	V <sub>IN</sub>	550	61.9k	1450	18.2k
5.5V to 15V	3.30V	2.2μF	22μF 1206	154k	AUX	650	49.9k	1400	19.6k
7.5V to 15V	5.00V	2.2μF	4.7μF 0805	93.1k	AUX	650	49.9k	1200	23.7k
9V to 24V	0.82V	10μF	200μF 1206	13M	≥2.8V, <16V	250	150k	250	150k
9V to 24V	1.00V	10μF	147μF 1206	1.87M	≥2.8V, <16V	300	124k	450	79k
9V to 24V	1.20V	2.2μF	100μF 1206	953k	≥2.8V, <16V	450	79k	500	69.8k
9V to 24V	1.50V	2.2μF	100μF 1206	549k	≥2.8V, <16V	450	79k	615	54.9k
9V to 24V	1.80V	2.2μF	100μF 1206	383k	≥2.8V, <16V	450	79k	700	44.2k
9V to 24V	2.00V	2.2μF	68μF 1206	324k	≥2.8V, <16V	450	79k	750	42.2k
9V to 24V	2.20V	2.2μF	47μF 1206	274k	≥2.8V, <16V	500	69.8k	800	39.2k
9V to 24V	2.50V	2.2μF	47μF 1206	226k	≥2.8V, <16V	550	61.9k	890	34.8k
9V to 24V	3.30V	2.2μF	22μF 1206	154k	AUX	650	49.9k	1150	25.5k
9V to 24V	5.00V	2.2μF	4.7μF 0805	93.1k	AUX	650	49.9k	1000	29.4k
14.5V to 24V	8.00V	2.2μF	10μF 0805	53.6k	AUX	650	49.9k	800	39.2k
18V to 36V	0.82V	10μF	200μF 1206	13M	≥2.8V, <16V	250	150k	250	150k
18V to 36V	1.00V	10μF	147μF 1206	1.87M	≥2.8V, <16V	300	124k	300	124k
18V to 36V	1.20V	2.2μF	100μF 1206	953k	≥2.8V, <16V	350	105k	350	105k
18V to 36V	1.50V	2.2μF	100μF 1206	549k	≥2.8V, <16V	400	88.7k	400	88.7k
18V to 36V	1.80V	2.2μF	100μF 1206	383k	≥2.8V, <16V	450	79k	450	79k
18V to 36V	2.00V	2.2μF	68μF 1206	324k	≥2.8V, <16V	450	79k	500	69.8k
18V to 36V	2.20V	2.2μF	47μF 1206	274k	≥2.8V, <16V	450	79k	550	61.9k
18V to 36V	2.50V	2.2μF	47μF 1206	226k	≥2.8V, <16V	500	69.8k	615	54.9k
18V to 36V	3.30V	2.2μF	22μF 1206	154k	AUX	650	49.9k	750	42.2k
18V to 36V	5.00V	2.2μF	4.7μF 0805	93.1k	AUX	800	39.2k	890	34.8k
18V to 36V	8.00V	2.2μF	10μF 0805	53.6k	AUX	650	49.9k	800	39.2k
20V to 36V	10.00V	2.2μF	10μF 0805	42.2k	AUX	615	54.9k	750	42.2k
4.75V to 32V	-3.30V	2.2μF	22μF 1206	154k	AUX	550	61.9k	800	39.2k
7V to 31V	-5.00V	2.2μF	10μF 0805	93.1k	AUX	800	39.2k	1100	26.7k
15V to 28V	-8.00V	2.2μF	10μF 0805	53.6k	AUX	800	39.2k	1600	15.8k

## APPLICATIONS INFORMATION

at audio frequencies, generating audible noise. Since the LTM8023 operates at a lower current limit during Burst Mode operation, the noise is typically very quiet to a casual ear.

If this audible noise is unacceptable, use a high performance electrolytic capacitor at the output. The input capacitor can be a parallel combination of a 2.2 $\mu$ F ceramic capacitor and a low cost electrolytic capacitor.

A final precaution regarding ceramic capacitors concerns the maximum input voltage rating of the LTM8023. A ceramic input capacitor combined with trace or cable inductance forms a high Q (under damped) tank circuit. If the LTM8023 circuit is plugged into a live supply, the input voltage can ring to twice its nominal value, possibly exceeding the device's rating. This situation is easily avoided; see the Hot-Plugging Safely section.

### Frequency Selection

The LTM8023 uses a constant frequency PWM architecture that can be programmed to switch from 200kHz to 2.4MHz by using a resistor tied from the  $R_T$  pin to ground. Table 2 provides a list of  $R_T$  resistor values and their resultant frequencies.

**Table 2. Switching Frequency vs  $R_T$  Value**

SWITCHING FREQUENCY (MHz)	$R_T$ VALUE (k $\Omega$ )
0.2	187
0.3	121
0.4	88.7
0.5	68.1
0.6	56.2
0.7	46.4
0.8	40.2
0.9	34
1.0	29.4
1.2	23.7
1.4	19.1
1.6	16.2
1.8	13.3
2.0	11.5
2.2	9.76
2.4	8.66

### Operating Frequency Tradeoffs

It is recommended that the user apply the optimal  $R_T$  value given in Table 1 for the input and output operating condition. System level or other considerations, however, may necessitate another operating frequency. While the LTM8023 is flexible enough to accommodate a wide range of operating frequencies, a haphazardly chosen one may result in undesirable operation under certain operating or fault conditions. A frequency that is too high can reduce efficiency, generate excessive heat or even damage the LTM8023 if the output is overloaded or short circuited. A frequency that is too low can result in a final design that has too much output ripple or too large of an output cap.

The maximum frequency (and attendant  $R_T$  value) at which the LTM8023 should be allowed to switch is given in Table 1 in the  $f_{(MAX)}$  column, while the recommended frequency (and  $R_T$  value) for optimal efficiency over the given input condition is given in the  $f_{OPTIMAL}$  column.

There are additional conditions that must be satisfied if the synchronization function is used. Please refer to the Synchronization section for details.

### BIAS Pin Considerations

The BIAS pin is used to provide drive power for the internal power switching stage and operate internal circuitry. For proper operation, it must be powered by at least 2.8V. If the output voltage is programmed to be 2.8V or higher, simply tie BIAS to  $V_{OUT}$ . If  $V_{OUT}$  is less than 2.8V, BIAS can be tied to  $V_{IN}$  or some other voltage source. In all cases, ensure that the maximum voltage at the BIAS pin is both less than 16V and the sum of  $V_{IN}$  and BIAS is less than 56V. If BIAS power is applied from a remote or noisy voltage source, it may be necessary to apply a decoupling capacitor locally to the LTM8023.

### Load Sharing

Two or more LTM8023's may be paralleled to produce higher currents. To do this, tie the  $V_{IN}$ , ADJ,  $V_{OUT}$  and SHARE pins of all the paralleled LTM8023's together. To ensure

## APPLICATIONS INFORMATION

that paralleled modules start up together, the RUN/SS pins may be tied together, as well. If the RUN/SS pins are not tied together, make sure that the same valued soft-start capacitors are used for each module. An example of two LTM8023 modules configured for load sharing is given in the Typical Applications section.

### Burst Mode Operation

To enhance efficiency at light loads, the LTM8023 automatically switches to Burst Mode operation which keeps the output capacitor charged to the proper voltage while minimizing the input quiescent current. During Burst Mode operation, the LTM8023 delivers single cycle bursts of current to the output capacitor followed by sleep periods where the output power is delivered to the load by the output capacitor. In addition,  $V_{IN}$  and BIAS quiescent currents are reduced to typically  $20\mu\text{A}$  and  $50\mu\text{A}$  respectively during the sleep time. As the load current decreases towards a no load condition, the percentage of time that the LTM8023 operates in sleep mode increases and the average input current is greatly reduced, resulting in higher efficiency.

Burst Mode operation is enabled by tying SYNC to GND. To disable Burst Mode operation, tie SYNC to a stable voltage above  $0.7V$ . Do not leave the SYNC pin floating.

### Minimum Input Voltage

The LTM8023 is a step down converter, so a minimum amount of headroom is required to keep the output in regulation. In addition, the input voltage required to turn on is higher than that required to run, and depends upon whether the RUN/SS is used. As shown in Figure 2, it takes only about  $3.5V_{IN}$  for the LTM8023 to run a  $3.3V$  output at light load. If RUN/SS is pulled up to  $V_{IN}$ , it takes  $5.5V_{IN}$  to start. If the LTM8023 is enabled via the RUN/SS pin, the minimum voltage to start at light loads is lower, about  $4.5V$ . A similar curve for  $5V_{OUT}$  operation is also provided in Figure 2.

### Soft-Start

The RUN/SS pin can be used to soft-start the LTM8023, reducing the maximum input current during startup. The

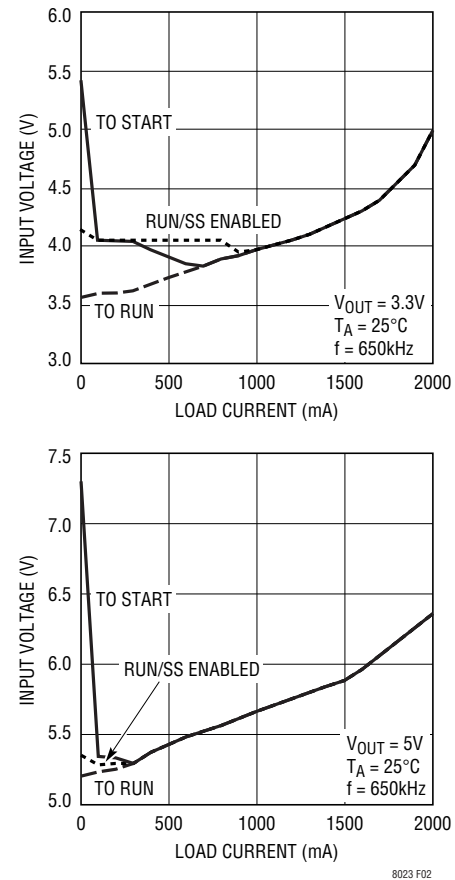

Figure 2. The LTM8023 Needs More Voltage to Start Than to Run

RUN/SS pin is driven through an external RC filter to create a voltage ramp at this pin. Figure 3 shows the startup and shutdown waveforms with the soft-start circuit. By choosing an appropriate RC time constant, the peak startup

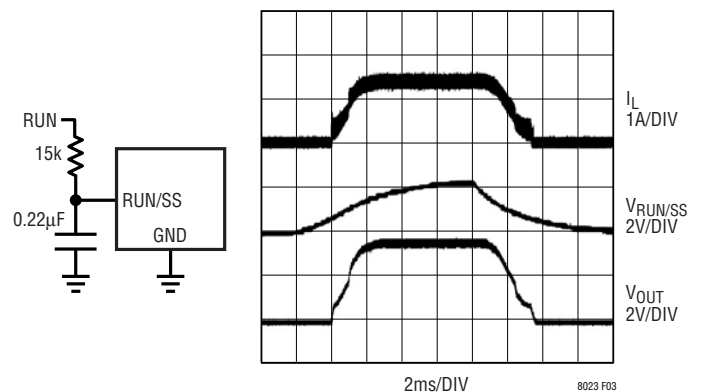

Figure 3. To Soft-Start the LTM8023, Add a Resistor and Capacitor to the RUN/SS Pin

## APPLICATIONS INFORMATION

current can be reduced to the current that is required to regulate the output, with no overshoot. Choose the value of the resistor so that it can supply at least 20 $\mu$ A when the RUN/SS pin reaches 2.5V.

### Synchronization

The internal oscillator of the LTM8023 can be synchronized by applying an external 250kHz to 2MHz clock to the SYNC pin. *Do not leave this pin floating.* The resistor tied from the  $R_T$  pin to ground should be chosen such that the LTM8023 oscillates 20% lower than the intended synchronization frequency (see the Frequency Selection section).

The LTM8023 will not enter Burst Mode operation while synchronized to an external clock, but will instead skip pulses to maintain regulation.

### Shorted Input Protection

Care needs to be taken in systems where the output will be held high when the input to the LTM8023 is absent. This may occur in battery charging applications or in battery backup systems where a battery or some other supply is diode OR-ed with the LTM8023's output. If the  $V_{IN}$  pin is allowed to float and the  $\overline{SHDN}$  pin is held high (either by a logic signal or because it is tied to  $V_{IN}$ ), then the LTM8023's internal circuitry will pull its quiescent current through its internal power switch. This is fine if your system can tolerate a few milliamps in this state. If you ground the  $\overline{SHDN}$  pin, the SW pin current will drop to essentially zero. However, if the  $V_{IN}$  pin is grounded while the output is held high, then parasitic diodes inside the LTM8023 can pull large currents from the output through the  $V_{IN}$  pin. Figure 4 shows a circuit that will run only when the input voltage is present and that protects against a shorted or reversed input.

### PCB Layout

Most of the headaches associated with PCB layout have been alleviated or even eliminated by the high level of integration of the LTM8023. The LTM8023 is nevertheless a switching power supply, and care must be taken to minimize EMI and ensure proper operation. Even with the

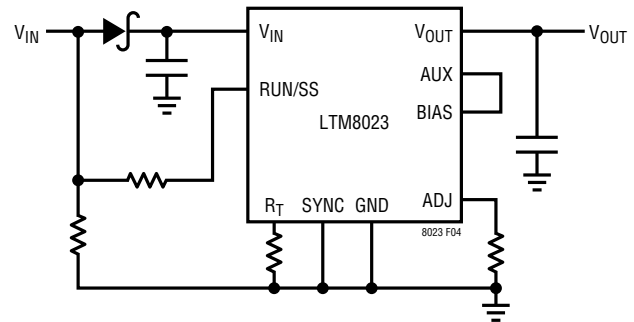
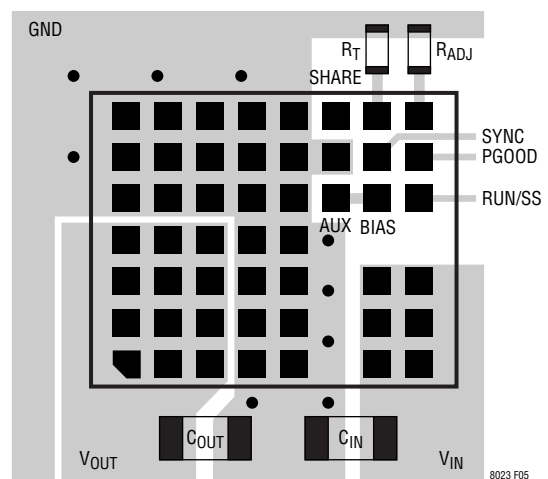

**Figure 4. The Input Diode Prevents a Shorted Input from Discharging a Backup Battery Tied to the Output. It Also Protects the Circuit from a Reversed Input. The LTM8023 Runs Only When the Input is Present.**

high level of integration, you may fail to achieve specified operation with a haphazard or poor layout. See Figure 5 for a suggested layout.

Ensure that the grounding and heatsinking are acceptable. A few rules to keep in mind are:

1. Place the  $R_{ADJ}$  and  $R_T$  resistors as close as possible to their respective pins.
2. Place the  $C_{IN}$  capacitor as close as possible to the  $V_{IN}$  and GND connection of the LTM8023.
3. Place the  $C_{OUT}$  capacitor as close as possible to the  $V_{OUT}$  and GND connection of the LTM8023.



**Figure 5. Layout Showing Suggested External Components, GND Plane and Thermal Vias**

## APPLICATIONS INFORMATION

- Place the  $C_{IN}$  and  $C_{OUT}$  capacitors such that their ground current flow directly adjacent or underneath the LTM8023.
- Connect all of the GND connections to as large a copper pour or plane area as possible on the top layer. Avoid breaking the ground connection between the external components and the LTM8023.
- Use vias to connect the GND copper area to the boards internal ground plane. Liberally distribute these GND vias to provide both a good ground connection and thermal path to the internal planes of the printed circuit board.

### Hot-Plugging Safely

The small size, robustness and low impedance of ceramic capacitors make them an attractive option for the input bypass capacitor of LTM8023. However, these capacitors can cause problems if the LTM8023 is plugged into a live supply (see Linear Technology Application Note 88 for a complete discussion). The low loss ceramic capacitor combined with stray inductance in series with the power source forms an under-damped tank circuit, and the voltage at the  $V_{IN}$  pin of the LTM8023 can ring to twice the nominal input voltage, possibly exceeding the LTM8023's rating and damaging the part. If the input supply is poorly controlled or the user will be plugging the LTM8023 into an energized supply, the input network should be designed to prevent this overshoot. Figure 6 shows the waveforms that result when an LTM8023 circuit is connected to a 24V supply through six feet of 24-gauge twisted pair. The first plot is the response with a 2.2 $\mu$ F ceramic capacitor at the input. The input voltage rings as high as 35V and the input current peaks at 20A. One method of damping the tank circuit is to add another capacitor with a series resistor to the circuit. In Figure 6b an aluminum electrolytic capacitor has been added. This capacitor's high equivalent series resistance damps the circuit and eliminates the voltage overshoot. The extra capacitor improves low frequency ripple filtering and can slightly improve the efficiency of the circuit, though it is likely to be the largest component in the circuit. An alternative solution is shown in Figure 6c. A 0.7 $\Omega$

resistor is added in series with the input to eliminate the voltage overshoot (it also reduces the peak input current). A 0.1 $\mu$ F capacitor improves high frequency filtering. This solution is smaller and less expensive than the electrolytic capacitor. For high input voltages its impact on efficiency is minor, reducing efficiency less than one half percent for a 5V output at full load operating from 24V.

### Thermal Considerations

The LTM8023 output current may need to be derated if it is required to operate in a high ambient temperature or deliver a large amount of continuous power. The amount of current derating is dependent upon the input voltage, output power and ambient temperature. The derating curves given in the Typical Performance Characteristics section can be used as a guide. These curves were generated by a LTM8023 mounted to a 33cm<sup>2</sup> 4-layer FR4 printed circuit board. Boards of other sizes and layer count can exhibit different thermal behavior, so it is incumbent upon the user to verify proper operation over the intended system's line, load and environmental operating conditions.

The die temperature of the LTM8023 must be lower than the maximum rating of 125°C, so care should be taken in the layout of the circuit to ensure good heat sinking of the LTM8023. To estimate the junction temperature, approximate the power dissipation within the LTM8023 by applying the typical efficiency stated in this datasheet to the desired output power, or, if you have an actual module, by taking a power measurement. Then calculate the temperature rise of the LTM8023 junction above the surface of the printed circuit board by multiplying the module's power dissipation by the thermal resistance. The actual thermal resistance of the LTM8023 to the printed circuit board depends upon the layout of the circuit board, but the thermal resistance given on page 2, which is based upon a 33cm<sup>2</sup> 4-layer FR4 PC board, can be used a guide.

Finally, be aware that at high ambient temperatures the internal Schottky diode will have significant leakage current (see Typical Performance Characteristics) increasing the quiescent current of the LTM8023.

## APPLICATIONS INFORMATION

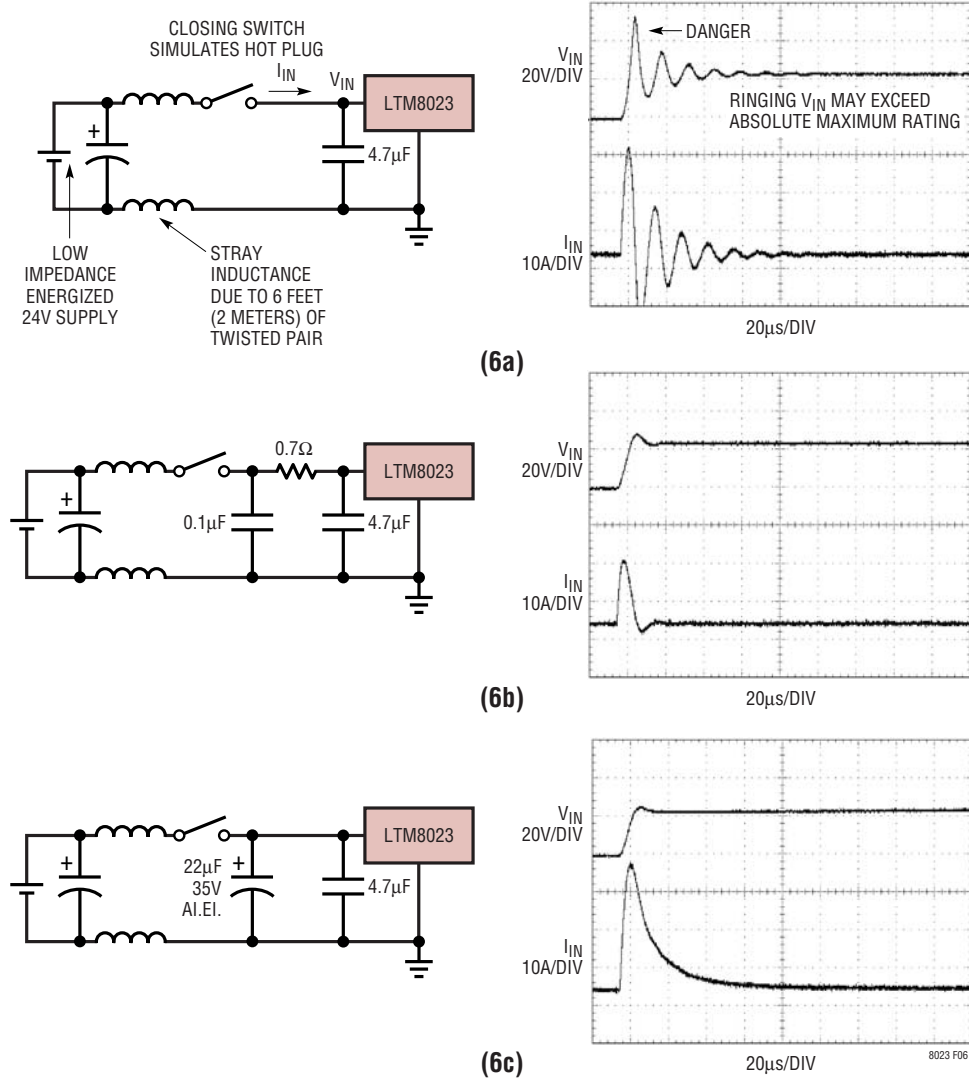

**Figure 6. A Well Chosen Input Network Prevents Input Voltage Overshoot and Ensures Reliable Operation When the LTM8023 is Connected to a Live Supply**

## TYPICAL APPLICATIONS

## 0.82V Step-Down Converter

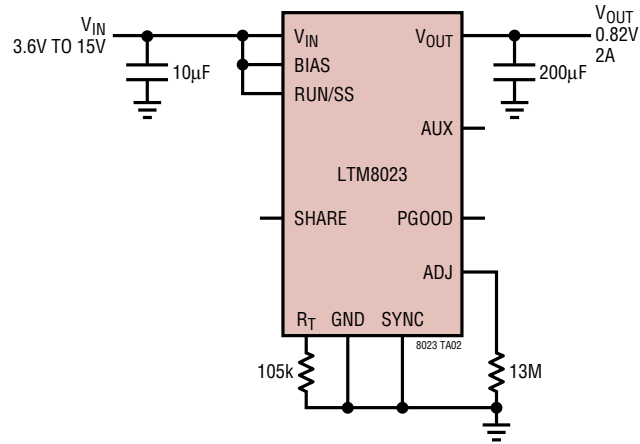

## 1.8V Step-Down Converter

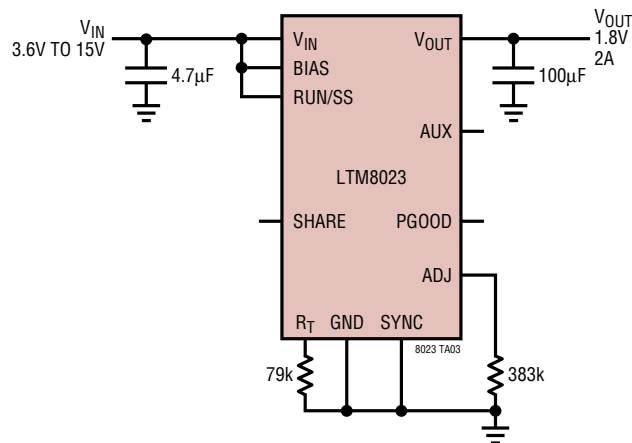

## TYPICAL APPLICATIONS

### 2.5V Step-Down Converter

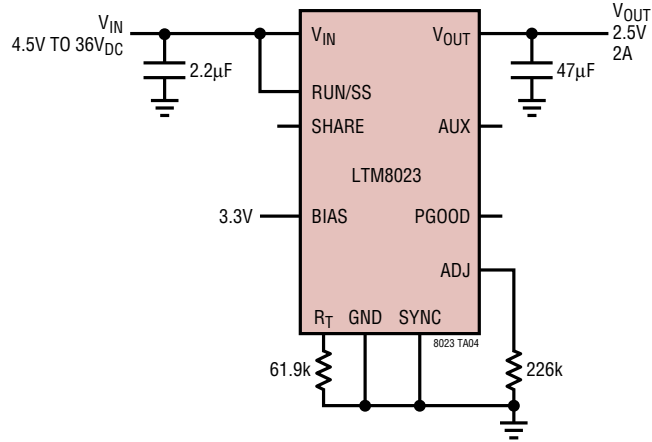

### 5V Step-Down Converter

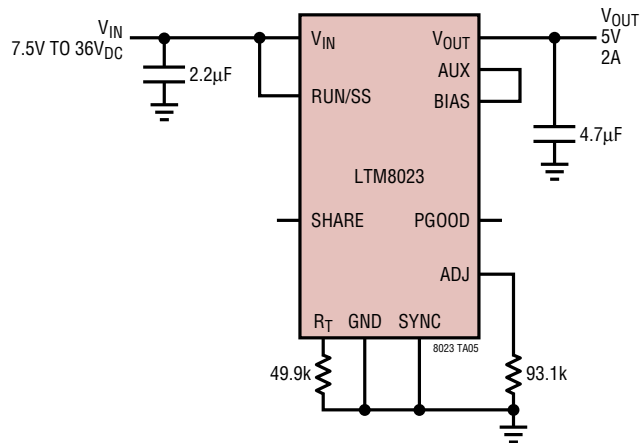



# TYPICAL APPLICATIONS

**-5V Positive to Negative Converter**

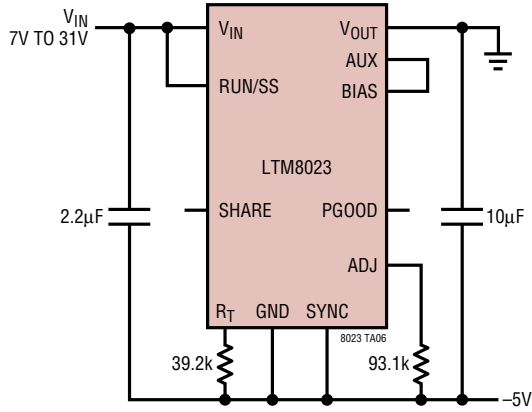

**-5V Positive to Negative Converter Load Current vs Input Voltage**

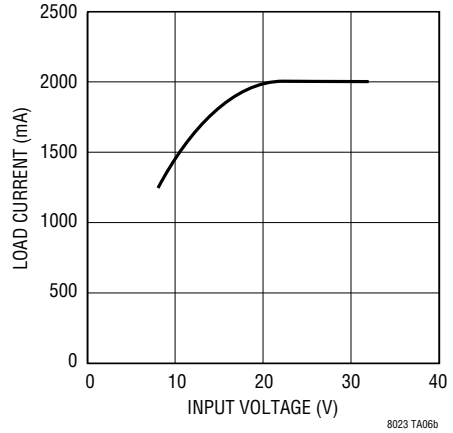

**Two LTM8023's in Parallel, 3.3V at 4A**

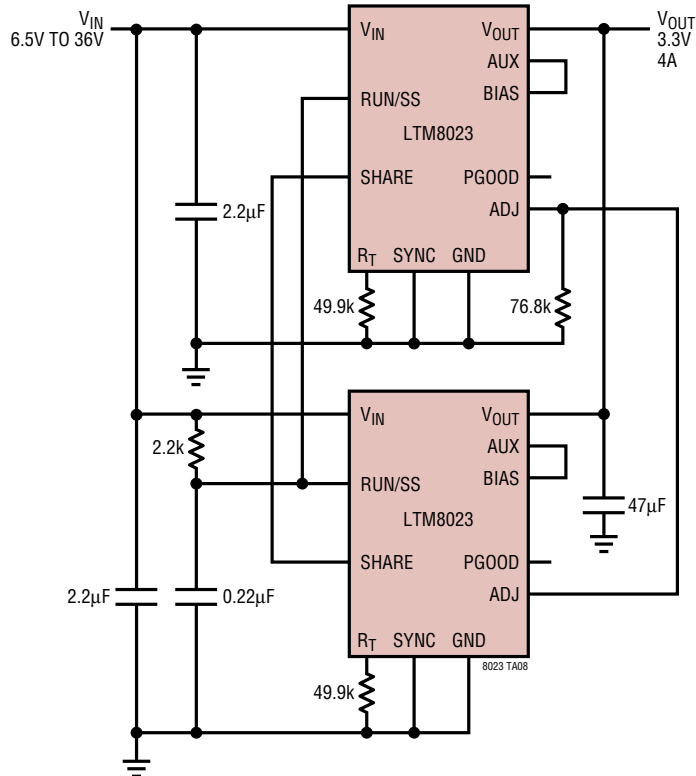

PACKAGE DESCRIPTION

**LGA Package**  
**50-Lead (11.25mm × 9.00mm × 2.82mm)**  
 (Reference LTC DWG # 05-08-1804 Rev B)

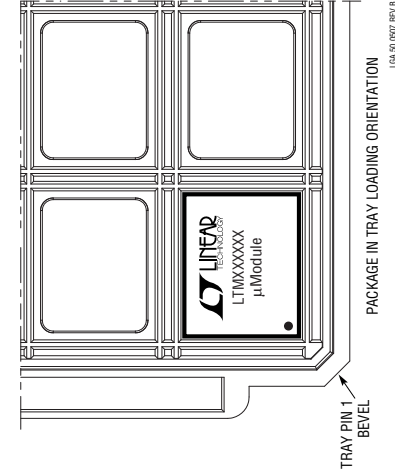
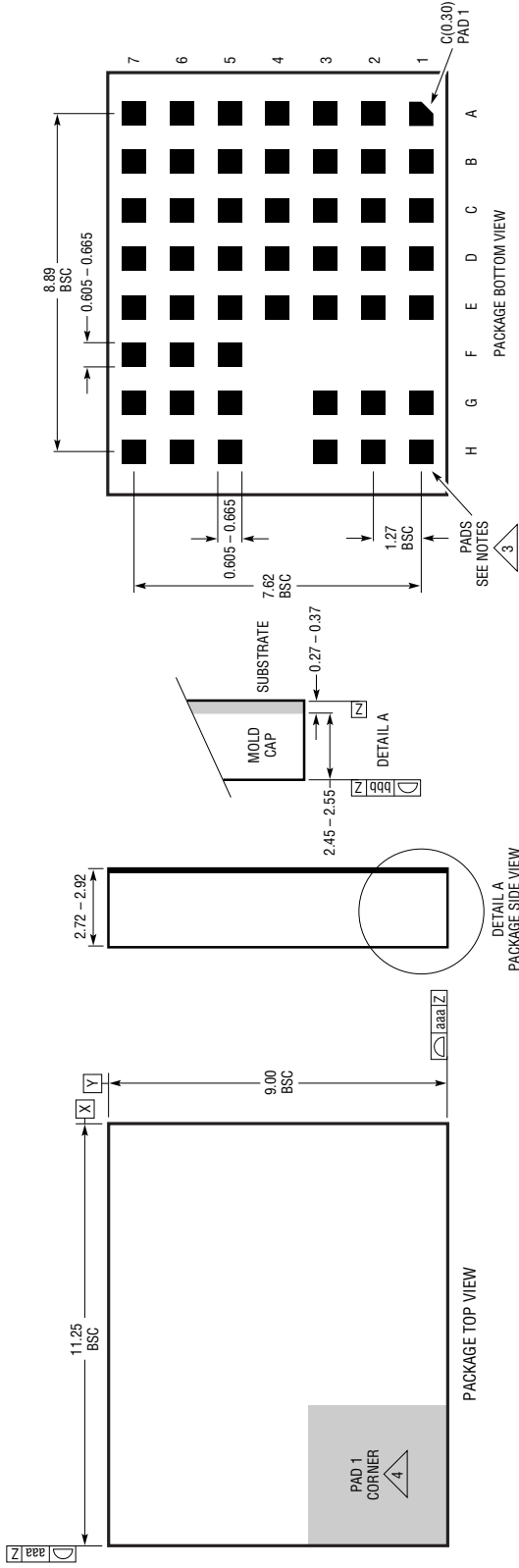

- NOTES:**
1. DIMENSIONING AND TOLERANCING PER ASME Y14.5M-1994
  2. ALL DIMENSIONS ARE IN MILLIMETERS
  3. LAND DESIGNATION PER JEDEC MO-222, SPP-010 AND SPP-020
  4. DETAILS OF PAD #1 IDENTIFIER ARE OPTIONAL BUT MUST BE LOCATED WITHIN THE ZONE INDICATED. THE PAD #1 IDENTIFIER MAY BE EITHER A MOLD OR A MARKED FEATURE
  5. PRIMARY DATUM - Z - IS SEATING PLANE
  6. THE TOTAL NUMBER OF PADS: 50

SYMBOL	TOLERANCE
aaa	0.15
bbb	0.10

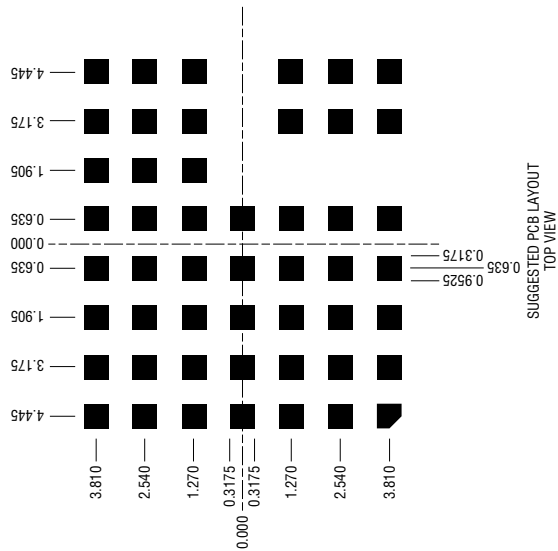

## PACKAGE DESCRIPTION

Table 3. Pin Assignment (Sorted by Pin Number)

PIN	SIGNAL DESCRIPTION	PIN	SIGNAL DESCRIPTION
A1	V <sub>OUT</sub>	D5	GND
A2	V <sub>OUT</sub>	D6	GND
A3	V <sub>OUT</sub>	D7	GND
A4	V <sub>OUT</sub>	E1	GND
A5	GND	E2	GND
A6	GND	E3	GND
A7	GND	E4	GND
B1	V <sub>OUT</sub>	E5	GND
B2	V <sub>OUT</sub>	E6	GND
B3	V <sub>OUT</sub>	E7	GND
B4	V <sub>OUT</sub>	F5	AUX
B5	GND	F6	GND
B6	GND	F7	SHARE
B7	GND	G1	V <sub>IN</sub>
C1	V <sub>OUT</sub>	G2	V <sub>IN</sub>
C2	V <sub>OUT</sub>	G3	V <sub>IN</sub>
C3	V <sub>OUT</sub>	G5	BIAS
C4	V <sub>OUT</sub>	G6	SYNC
C5	GND	G7	R <sub>T</sub>
C6	GND	H1	V <sub>IN</sub>
C7	GND	H2	V <sub>IN</sub>
D1	GND	H3	V <sub>IN</sub>
D2	GND	H5	RUN/SS
D3	GND	H6	PGOOD
D4	GND	H7	ADJ

# LTM8023

## TYPICAL APPLICATION

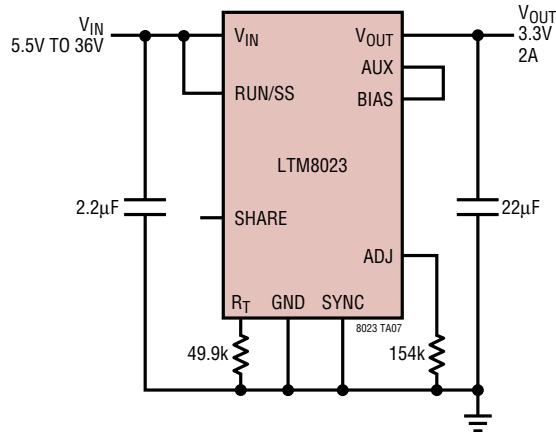

## RELATED PARTS

PART NUMBER	DESCRIPTION	COMMENTS
LTM4600/LTM4602	10A and 6A DC/DC $\mu$ Module	Pin Compatible, $4.5V \leq V_{IN} \leq 28V$ , $15mm \times 15mm \times 2.8mm$ LGA Package
LTM4601/LTM4603	12A and 6A DC/DC $\mu$ Module	Pin Compatible; Remote Sensing; PLL, Tracking and Margining, $4.5V \leq V_{IN} \leq 28V$
LTM4604	4A, Low $V_{IN}$ DC/DC $\mu$ Module	$2.375V \leq V_{IN} \leq 5.5V$ , $0.8V \leq V_{OUT} \leq 5V$ , $9mm \times 15mm \times 2.3mm$ LGA Package
LTM8020	200mA, 36V DC/DC $\mu$ Module	$4V \leq V_{IN} \leq 36V$ , $1.25V \leq V_{OUT} \leq 5V$ , $6.25mm \times 6.25mm \times 2.32mm$ LGA Package
LTM8022	1A, 36V DC/DC $\mu$ Module	$3.6V \leq V_{IN} \leq 36V$ , $0.8V \leq V_{OUT} \leq 10V$ , $11.25mm \times 9mm \times 2.82mm$ LGA Package