

M62423FP

DIGITAL SOUND CONTROLLER FOR MINI-COMPONENT STEREO

DESCRIPTION

The M62423FP is a digital sound controller IC for miniature unit audio systems. The IC, with serial data sent from a microcomputer, makes it easy to realize karaoke functions (voice canceling) and tone quality/sound field control such as surround and 3-band tone control.

FEATURES

- 32-pin shrink DIP
- Capable of controlling each function by serial data
 - Bass/treble/Mid 0, ± 3 , ± 6 , ± 10 dB
 - Surround [ON/OFF]
 - Bass boost [ON/OFF]
 - Voice canceling [ON/OFF]
 - Mute [ON/OFF]

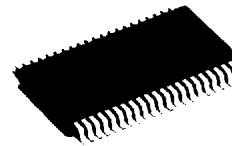

Outline 42P2R-A

0.8mm pitch 450mil SSOP
(8.4mm × 17.5mm × 2.0mm)

RECOMMENDED OPERATING CONDITIONS

- Supply voltage range V_{CC} , $V_{EE} = \pm 5.0$ to ± 8.0 V
- Rated supply voltage V_{CC} , $V_{EE} = \pm 7.0$ V

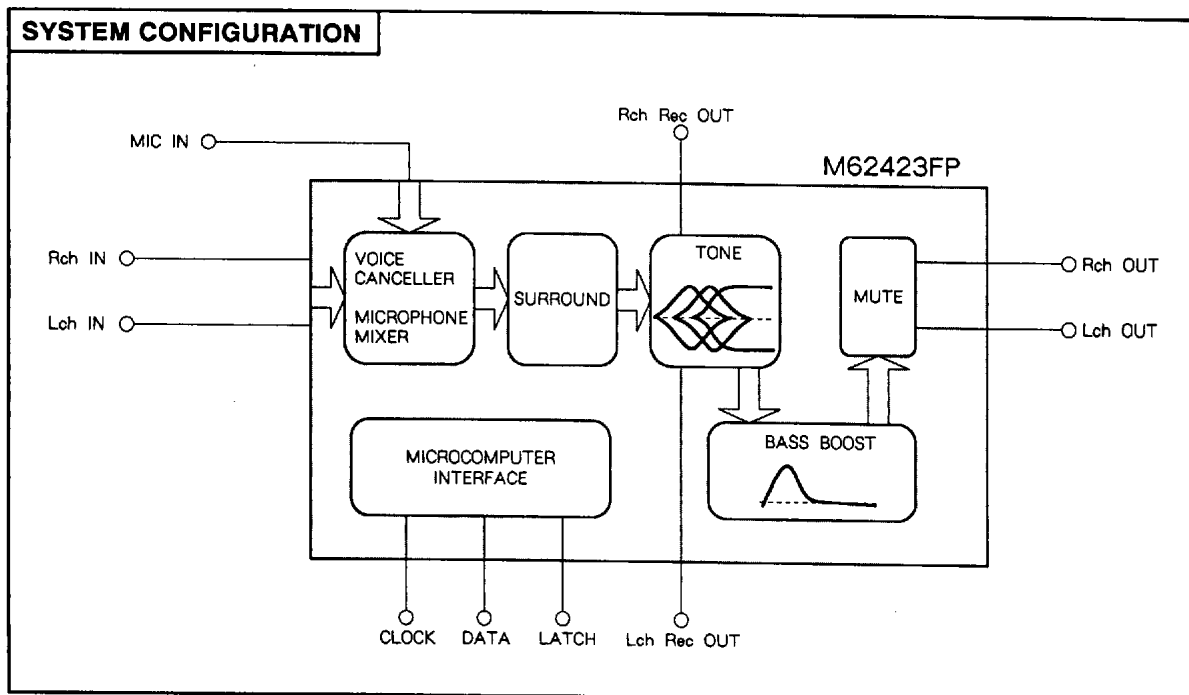

■ 6249826 0022234 558 ■

M62423FP

DIGITAL SOUND CONTROLLER FOR MINI-COMPONENT STEREO

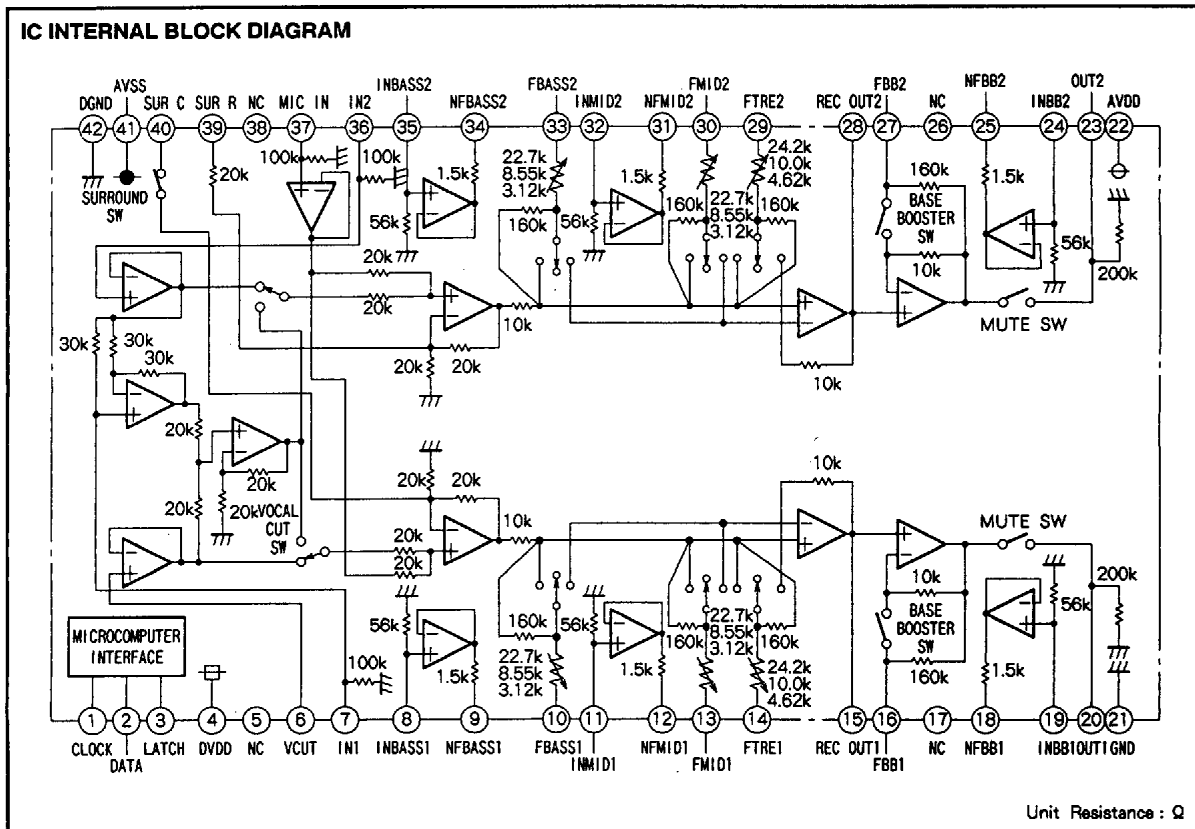
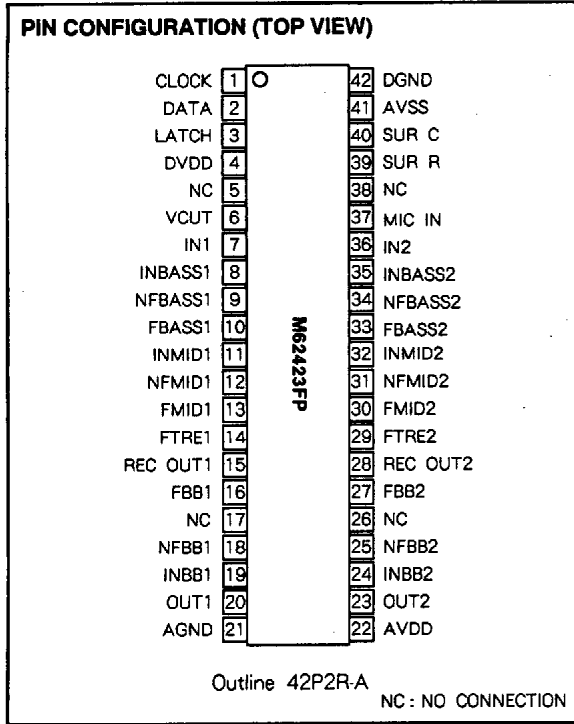

6249826 0022235 494



DIGITAL SOUND CONTROLLER FOR MINI-COMPONENT STEREO

ABSOLUTE MAXIMUM RATINGS

Symbol	Parameter	Rated	Unit
AVDD, AVSS	Analog supply voltage	± 8.5	V
DVDD	Digital supply voltage	7.0	V
Pa	Power dissipation (Ta ≤ 25°C)	1250	mW
Kθ	Thermal derating (Ta > 25°C)	9.5	mW/°C
ToPr	Operating temperature	-20 to +75	°C
Tstg	Storage temperature	-55 to +125	°C

ELECTRICAL CHARACTERISTICS (Ta = 25°C, AVDD = 7V, AVSS = -7V, DVDD = 5V, unless otherwise noted.)

Tone control and bass boost are set to 0dB.)

(1) Power supply characteristics

Symbol	Parameter	Test conditions	Limits			Unit
			Min	Typ	Max	
AIdd	Circuit current of analog positive power supply	Current at pin ② with AVDD = 7V, AVSS = -7V No signal	-	22	-	mA
AISS	Circuit current of analog negative power supply	Circuit current at pin ④ with AVDD = 7V, AVSS = -7V No signal	-	-22	-	mA
DIdd	Circuit current of digital power supply	Current at pin ④ with DVDD = 5V No signal	-	0	-	µA

(2) Characteristics of the digital block

Symbol	Parameter	Test conditions	Limits			Unit
			Min	Typ	Max	
VIL	Input voltage ("L" level)	CLOCK, DATA, LATCH pins	0	-	0.3·DVDD	V
VIH	Input voltage ("H" level)		0.7·DVDD	-	DVDD	V
IL	Output voltage ("L" level)	VIN = 0	-10	-	10	µA
IiH	Input current ("H" level)	VIN = DVDD	-	-	10	µA
FCLK	CLOCK frequency		-	-	250	kHz
tWHC	CLOCK pulse width		4.0	-	-	µS
tSD	DATA setup time		1.0	-	-	µS
tHD	DATA hold time		1.0	-	-	µS
tWHI	LATCH pulse width		2.0	-	-	µS
tSI	LATCH setup time		1.0	-	-	µS

DIGITAL SOUND CONTROLLER FOR MINI-COMPONENT STEREO

(3) Input/Output characteristics

Symbol	Parameter	Test conditions	Limits			Unit
			Min	Typ	Max	
R _{IN}	Input resistance	Pin ①, ②, T _a = 25 °C	50	100	200	kΩ
V _{IM}	Max. input voltage	Input to pin ①, ②, ③, ④, output from pin ⑤, ⑥	3.0	4.0	-	Vrms
V _{ODC}	Output pin voltage	Pin ⑤, ⑥, no signal	-0.15	0	0.15	V
V _{REDC}		Pin ⑦, ⑧, no signal	-0.1	0	0.1	V
G _V	Pass gain	V _{IN} = 1Vrms, flat. pin ⑤, ⑥ - ①, ② gains	-1	0	1	dB
V _{ONO}	Output noise voltage	JIS-A filter, no signal	-	7.0	20	μVrms
V _{RECNO}		R _g = 10k Ω	pin ⑤, ⑥	-	5.5	15
THD	Distortion factor	pin ⑤, ⑥. V _o = 0.5Vrms, R _L = 30k Ω	-	0.02	0.8	%
THD _{REC}		pin ⑦, ⑧. V _o = 0.5Vrms, R _L = 10k Ω	-	0.01	0.4	%
CT	Crosstalk between channels	Between pin ①, ② - ⑤, ⑥ lines V _o = 1Vrms, R _L = 30k Ω	-60	-65	-	dB
CT _{REC}		Between pin ①, ② - ⑦, ⑧ lines V _o = 1Vrms, R _L = 10k Ω	-60	-65	-	dB

(4) Tone control characteristics

Symbol	Parameter	Test conditions	Limits			Unit
			Min	Typ	Max	
G _{BOOST1}	Tone control voltage gain	f = 1kHz, V _o = 1Vrms Input pin ①, ② - output pin ⑤, ⑥ gain	2	3	4	dB
G _{BOOST2}			5	6	7	dB
G _{BOOST3}			8.5	10	11.5	dB
G _{CUT1}			-4	-3	-2	dB
G _{CUT2}			-7	-6	-5	dB
G _{CUT3}			-11.5	-10	-8.5	dB
BALTON	Balance between channels	f = 1kHz, V _o = 1Vrms Each of boost and cut conditions	-1	0	+1	dB

(5) Bass boost characteristics

Symbol	Parameter	Test conditions	Limits			Unit
			Min	Typ	Max	
G _{DD}	Bass boost voltage gain	f = 1kHz, V _o = 1Vrms Pin ⑤, ⑥, R _L = 3.3k	8.5	10	11.5	dB
BALDD	Graphic equalizer balance between channels	f = 1kHz, V _o = 1Vrms Defference in pin ⑤ - ⑥ gain	-1	0	+1	dB

(6) Microphone amplifier Input/output characteristics

Symbol	Parameter	Test conditions	Limits			Unit
			Min	Typ	Max	
R _{micin}	Input resistance	Pin ⑩	50	100	200	kΩ
V _{IMmic}	Max. input voltage	FLAT, R _L = 30kΩ, THD = 1 % Measure input at pin ⑩, outputs at pin ⑪, ⑫	3.0	4.0	-	Vrms
G _{Vmic}	Pass gain	pin ⑪, ⑫ - ⑬ voltage gains V _o = 0.5Vrms, R _L = 30kΩ	-2	0	2	dB
THD _{mic}	Distortion factor	pin ⑪, ⑫ V _o = 0.5Vrms, R _L = 30kΩ	-	0.02	0.8	%
BAL _{mic}	Balance between channels	Difference in voltage gain between pin ⑪, ⑫	-1	0	1	dB

DIGITAL SOUND CONTROLLER FOR MINI-COMPONENT STEREO

DIGITAL CONTROL SPECIFICATIONS

Digital format

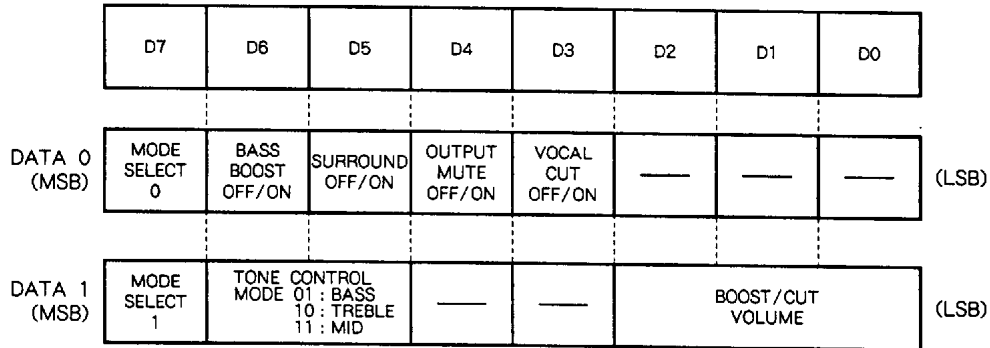

Signal name	Function	Signal name	Function																																								
D0	Fixed to "0"	D0	<table border="1" style="font-size: small;"> <tr> <td>D2</td> <td>D1</td> <td>D0</td> <td>Boosting / cutting volume</td> <td>D2</td> <td>D1</td> <td>D0</td> <td>Boosting / cutting volume</td> </tr> <tr> <td>0</td> <td>0</td> <td>0</td> <td>+0dB</td> <td>1</td> <td>0</td> <td>0</td> <td>-0dB</td> </tr> <tr> <td>0</td> <td>0</td> <td>1</td> <td>+3dB</td> <td>1</td> <td>0</td> <td>1</td> <td>-3dB</td> </tr> <tr> <td>0</td> <td>1</td> <td>0</td> <td>+6dB</td> <td>1</td> <td>1</td> <td>0</td> <td>-6dB</td> </tr> <tr> <td>0</td> <td>1</td> <td>1</td> <td>+10dB</td> <td>1</td> <td>1</td> <td>1</td> <td>-10dB</td> </tr> </table>	D2	D1	D0	Boosting / cutting volume	D2	D1	D0	Boosting / cutting volume	0	0	0	+0dB	1	0	0	-0dB	0	0	1	+3dB	1	0	1	-3dB	0	1	0	+6dB	1	1	0	-6dB	0	1	1	+10dB	1	1	1	-10dB
D2	D1	D0		Boosting / cutting volume	D2	D1	D0	Boosting / cutting volume																																			
0	0	0		+0dB	1	0	0	-0dB																																			
0	0	1		+3dB	1	0	1	-3dB																																			
0	1	0	+6dB	1	1	0	-6dB																																				
0	1	1	+10dB	1	1	1	-10dB																																				
D1	Fixed to "0"	D1	<table border="1" style="font-size: small;"> <tr> <td>D5</td> <td>D6</td> <td>Mode</td> </tr> <tr> <td>0</td> <td>1</td> <td>Bass</td> </tr> <tr> <td>1</td> <td>0</td> <td>Treble</td> </tr> <tr> <td>1</td> <td>1</td> <td>MID</td> </tr> </table>	D5	D6	Mode	0	1	Bass	1	0	Treble	1	1	MID																												
D5	D6	Mode																																									
0	1	Bass																																									
1	0	Treble																																									
1	1	MID																																									
D2	Fixed to "0"	D2	Tone control mode																																								
D3	Vocal cut disabled by "0" Vocal cut enabled by "1"	D3		Fixed to "0"																																							
D4	Output mute disabled by "0" Output mute enabled by "1"	D4	Fixed to "0"																																								
D5	Sorround disabled by "0" Sorround enabled by "1"	D5	Tone control mode																																								
D6	Bass boost disabled by "0" Bass boost enabled by "1"	D6		Data 1 is selected by "1"																																							
D7	Mode select Data 0 is selected by "0"	D7	Mode select																																								

DATA TIMING (Recommended conditions)

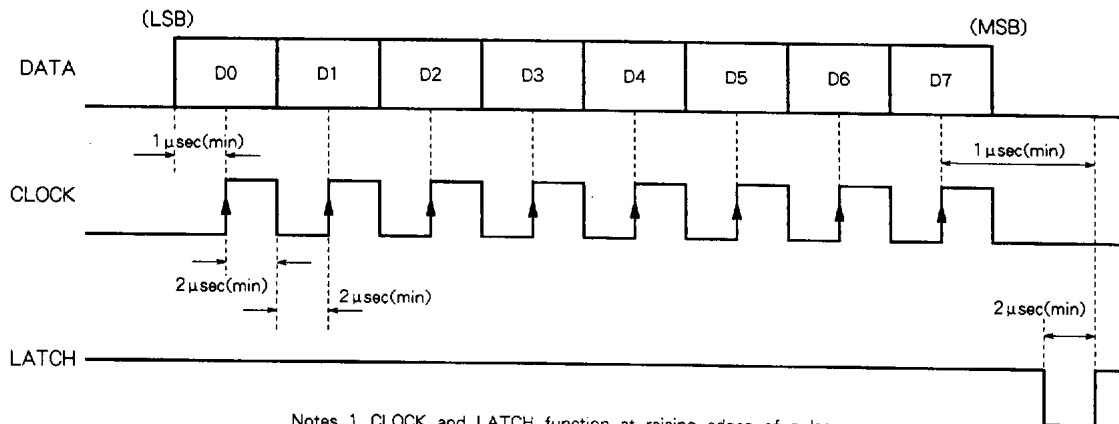

Notes 1. CLOCK and LATCH function at raising edges of pulse.
2. High level : 3.5V min. ; Low level : 1.5V max.

DIGITAL SOUND CONTROLLER FOR MINI-COMPONENT STEREO

FUNCTION DESCRIPTION

(1) Tone controller equivalent circuit

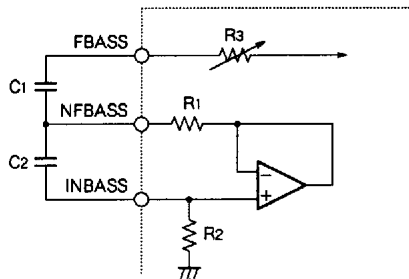

CENTER FREQUENCY
 $f_0 = \frac{1}{2\pi} \sqrt{C_1 \cdot C_2 \cdot R_1 \cdot R_2}$ [Hz]
 $Q = \sqrt{(C_2 \cdot R_2) / (C_1 \cdot R_1)}$

EXAMPLE : BASS BAND (f = 150Hz)
 R1 = 1.5k Ω , R2 = 56k Ω
 C1 = 0.82 μ , C2 = 0.015 μ

Fig. 1 A circuit equivalent to the inside of the tone controller

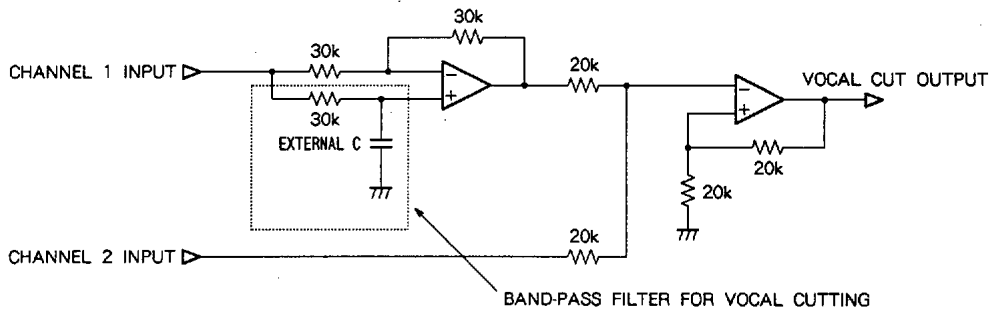

Fig. 2 is equivalent to Fig.1. To convert component constants, the equation below is used.

$L = C_2 \cdot R_1 \cdot R_2$

Fig. 2 An equivalent circuit using L

(2) Vocal cut block equivalent circuit



Note. The vocal cut output is monaural.

(3) Surround block equivalent circuit

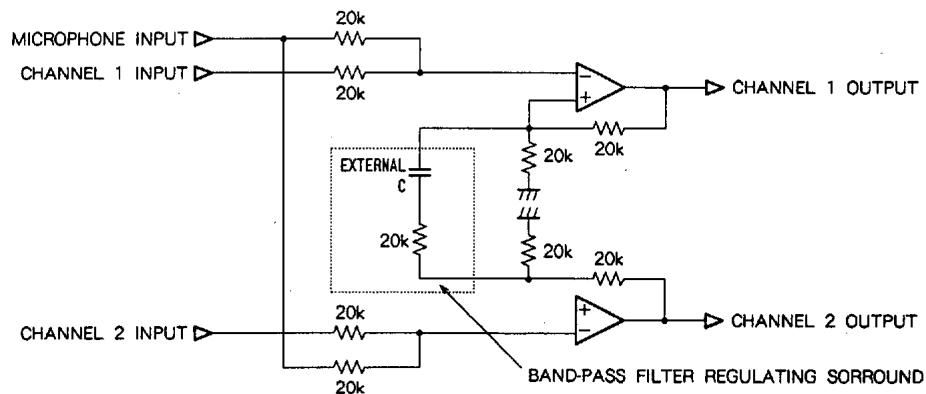

M62423FP

DIGITAL SOUND CONTROLLER FOR MINI-COMPONENT STEREO

TYPICAL CHARACTERISTICS

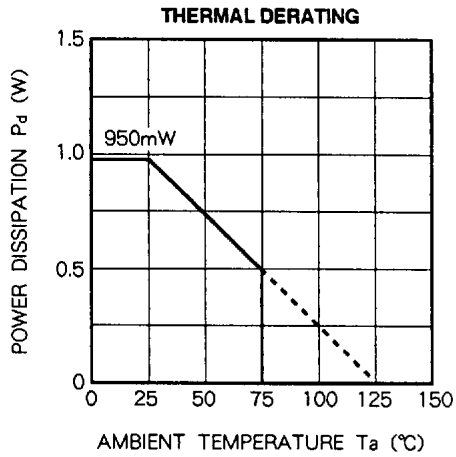

APPLICATION EXAMPLE

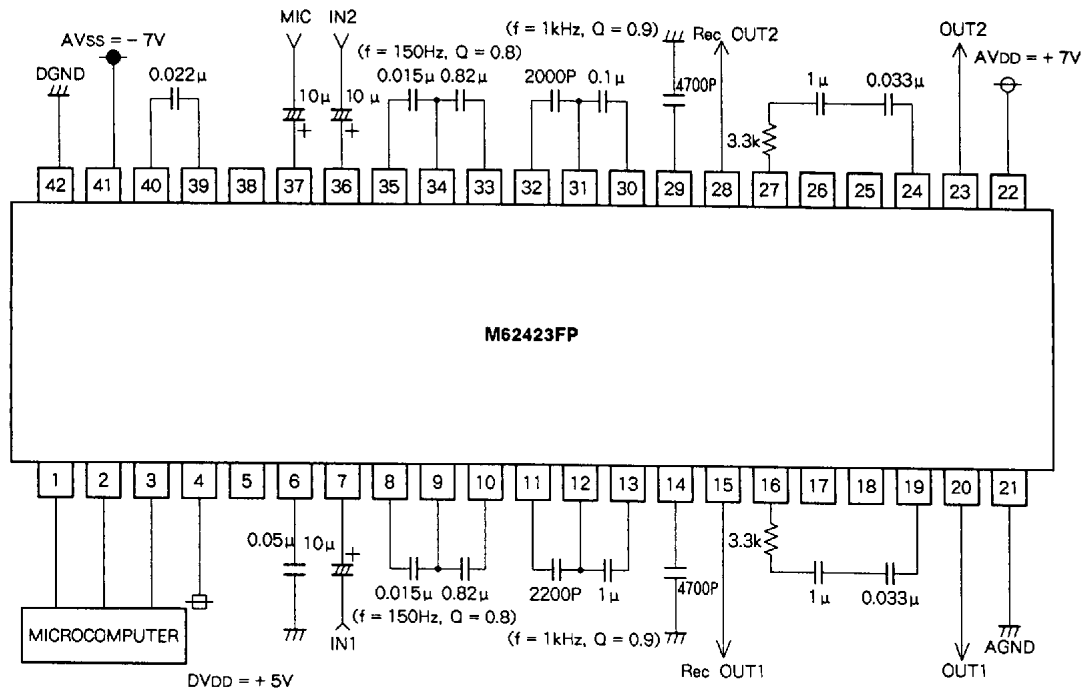

Unit Capacitance : F