



■ Features :

- 3 Phase 3 wire Δ AC 196 ~ 305V or 3 Phase 4 wire Y AC 340 ~ 530V wide range input
- High efficiency up to 91%
- Built-in active PFC function
- Protections: Short circuit / Overload / Over voltage / Over temperature / Fan fail
- Forced air cooling by built-in DC with fan speed control function
- Output voltage can be trimmed between 20~110% of the rated output voltage
- Output current can be adjusted between 20~100% of the rated output current
- Current sharing up to 3 units
- Alarm signal output (relay contact and open collector signal): AC fail, DC OK, fan fail, OTP
- Built-in 12V/0.1A auxiliary output for remote control
- Built-in remote ON-OFF control
- Built-in remote sense function
- 5 years warranty



SPECIFICATION

MODEL		RST-5000-24	RST-5000-48
OUTPUT	DC VOLTAGE	24V	48V
	RATED CURRENT	200A	105A
	CURRENT RANGE	0 ~ 200A	0 ~ 105A
	RATED POWER	4800W	5040W
	RIPPLE & NOISE (max.) Note.2	150mVp-p	200mVp-p
	VOLTAGE ADJ. RANGE	23.5 ~ 28.8V	47 ~ 57.6V
	VOLTAGE TOLERANCE Note.3	$\pm 1.0\%$	$\pm 1.0\%$
	LINE REGULATION	$\pm 0.5\%$	$\pm 0.5\%$
	LOAD REGULATION	$\pm 0.5\%$	$\pm 0.5\%$
	SETUP, RISE TIME	2200ms, 80ms at full load	
HOLD UP TIME (Typ.)	16ms at full load		
INPUT	VOLTAGE RANGE	3 Phase 3 wire Δ 196 ~ 305VAC or 3 Phase 4 wire Y 340 ~ 530VAC	
	FREQUENCY RANGE	47 ~ 63Hz	
	POWER FACTOR (Typ.)	0.95/230VAC(400VAC) at full load	
	EFFICIENCY (Typ.)	89%	91%
	AC CURRENT (Typ.)	15A/230VAC(3 Phase Δ) 9A/400VAC(3 Phase Y)	
	INRUSH CURRENT (Typ.)	50A/ Δ 230VAC(Y 400VAC)	
LEAKAGE CURRENT	<3.5mA / Δ 305VAC(Y 530VAC)		
PROTECTION	OVERLOAD	100 ~ 112% rated output power User adjustable continuous constant current limiting or constant current limiting with delay shutdown after 5 seconds, re-power on to recover	
	OVER VOLTAGE	30 ~ 33.6V	60 ~ 67.2V
	OVER TEMPERATURE	Protection type : Shut down o/p voltage, recovers automatically after temperature goes down	
FUNCTION	AUXILIARY POWER(AUX)	12V@0.1A(Only for Remote ON/OFF control)	
	REMOTE ON/OFF CONTROL	Please see the Function Manual	
	ALARM SIGNAL OUTPUT	Please see the Function Manual	
	OUTPUT VOLTAGE TRIM	4.8 ~ 26.4V	9.6 ~ 52.8V
	OUTPUT CURRENT TRIM	40 ~ 200A	21 ~ 105A
	CURRENT SHARING	Please see the Function Manual	
ENVIRONMENT	WORKING TEMP.	-30 ~ +70°C (Refer to "Derating Curve")	
	WORKING HUMIDITY	20~90% RH non-condensing	
	STORAGE TEMP., HUMIDITY	-40 ~ +85°C, 10 ~ 95% RH	
	TEMP. COEFFICIENT	$\pm 0.05\%/^{\circ}\text{C}$ (0 ~ 50°C)	
	VIBRATION	10 ~ 500Hz, 2G 10min./1cycle, 60min. each along X, Y, Z axes	
SAFETY & EMC (Note 4)	SAFETY STANDARDS	UL60950-1, TUV EN60950-1 approved	
	WITHSTAND VOLTAGE	I/P-O/P:3KVAC I/P-FG:2KVAC O/P-FG:0.5KVAC	
	ISOLATION RESISTANCE	I/P-O/P, I/P-FG, O/P-FG:100M Ohms / 500VDC / 25°C / 70% RH	
	EMC EMISSION	Compliance to EN55022 (CISPR22) Class A, EN61000-3-2,-3	
	EMC IMMUNITY	Compliance to EN61000-4-2,3,4,5,6,8,11, EN55024, EN61000-6-2, heavy industry level, criteria A	
OTHERS	MTBF	37.9K hrs min. MIL-HDBK-217F (25°C)	
	DIMENSION	480*211*83.5mm (L*W*H)	
	PACKING	10Kg; 1pcs/10.1Kg/1.15CUFT	
NOTE	<p>1. All parameters NOT specially mentioned are measured at Δ230VAC(Y 400VAC) input, rated load and 25°C of ambient temperature.</p> <p>2. Ripple & noise are measured at 20MHz of bandwidth by using a 12" twisted pair-wire terminated with a 0.1uf & 47uf parallel capacitor.</p> <p>3. Tolerance : includes set up tolerance, line regulation and load regulation.</p> <p>4. The power supply is considered a component which will be installed into a final equipment. The final equipment must be re-confirmed that it still meets EMC directives. For guidance on how to perform these EMC tests, please refer to EMI testing of component power supplies. (as available on http://www.meanwell.com)</p>		

Mechanical Specification

Case No.223A

Unit:mm

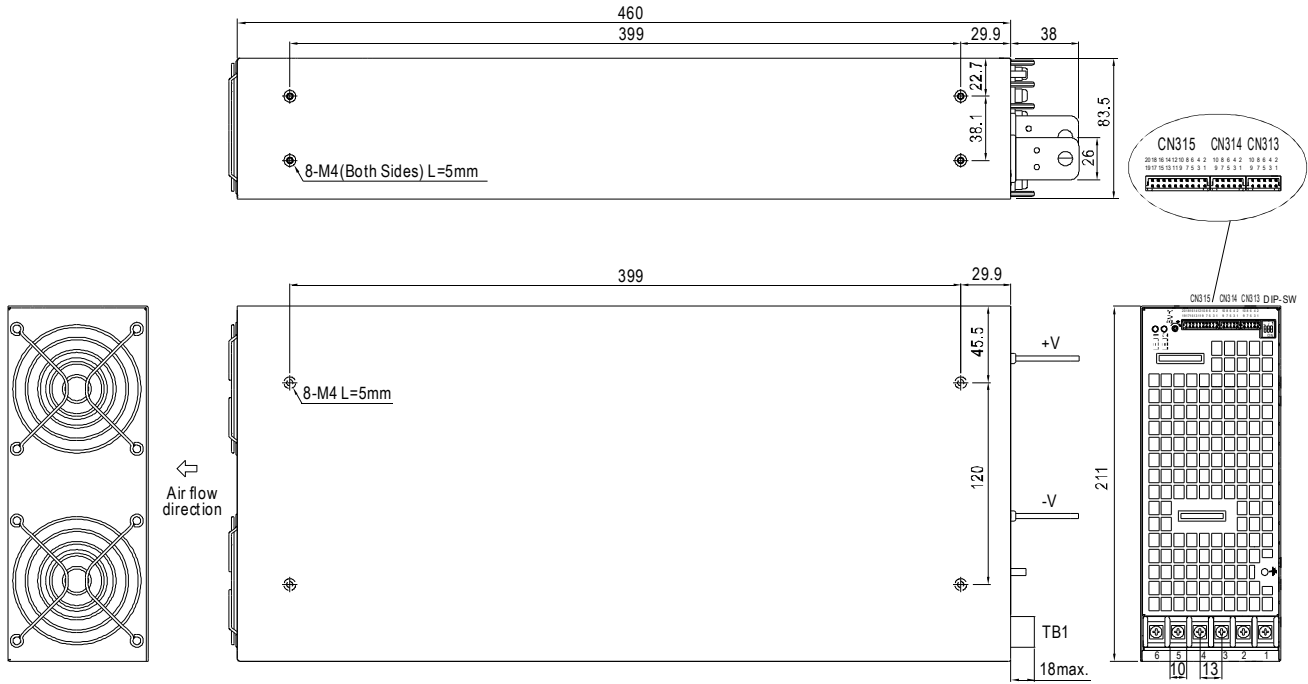

Terminal Pin No. Assignment

Pin No.	Assignment	Pin No.	Assignment
1	AC/L1	4	AC/N2
2	AC/N1	5	AC/L3
3	AC/L2	6	AC/N3

Control Pin No. Assignment(CN313,CN314) : HRS DF11-10DP-2DS or equivalent

Pin No.	Assignment	Pin No.	Assignment	Mating Housing	Terminal
1	CS-	6	PV+	HRS DF11-10DS or equivalent	HRS DF11-**SC or equivalent
2	CS+	7	PC-		
3	+S	8	RC-		
4	PV-	9	PC+		
5	-S	10	RC+		

Control Pin No. Assignment(CN315) : HRS DF11-20DP-2DS or equivalent

Pin No.	Assignment	Pin No.	Assignment	Pin No.	Assignment	Pin No.	Assignment	Mating Housing	Terminal
1	12V-AUX	6	AC-FAIL2-GND	11	OTP2-GND	16	DC-OK1-GND	HRS DF11-20DS or equivalent	HRS DF11-**SC or equivalent
2	DC-OK2-GND	7	-V	12	FAN-FAIL2-GND	17	AC-FAIL1-GND		
3	GND-AUX	8	AC-FAIL2	13	OTP1	18	FAN-FAIL1-GND		
4	DC-OK2	9	OTP2	14	DC-OK1	19	AC-FAIL1		
5	+V	10	FAN-FAIL2	15	OTP1-GND	20	FAN-FAIL1		

DIP-SW Position Assignment(DIP-SW): Please see the Function Manual.

Position	Assignment	Position	Assignment
1	OLP mode	3	PC mode
2	PV mode		



Block Diagram

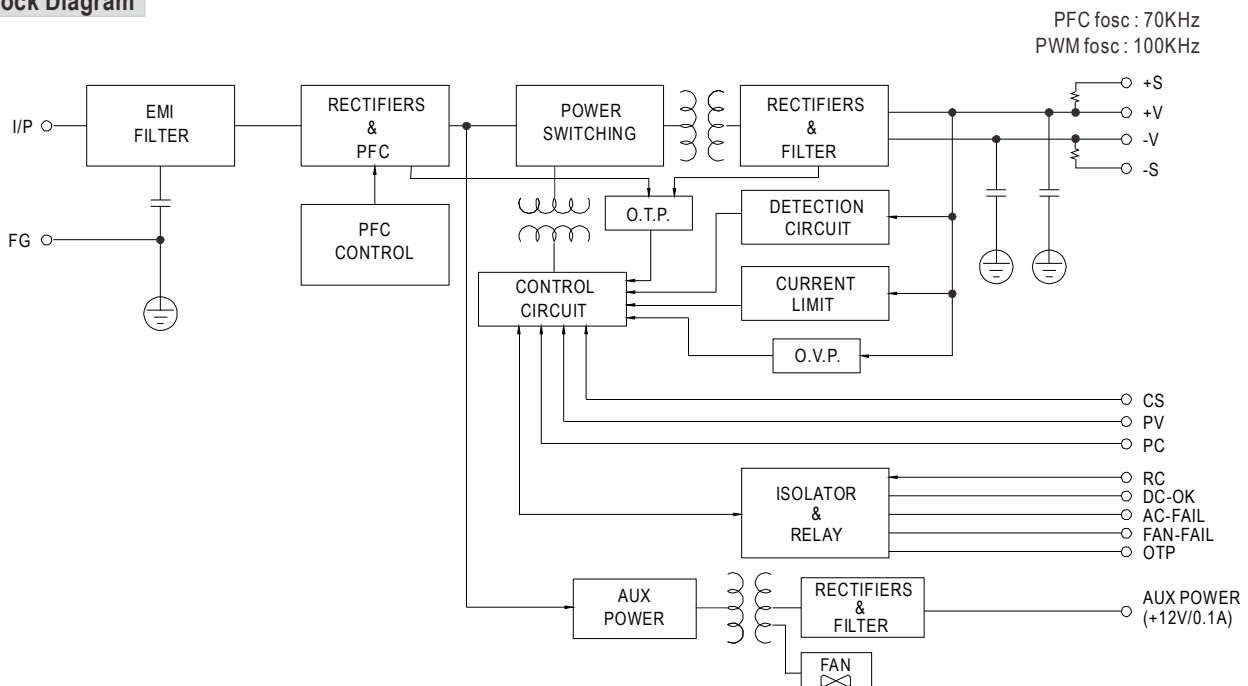

■ Function Description of CN313, 314

Pin No.	Function	Description
1	CS-	Current sharing signal. When units are connected in parallel, the CS pins of the units should be connected to allow current balance between units. Please refer to function manual for details.
2	CS+	
3	+S	The +S signal should be connected to the positive terminal of the load. The +S and -S leads should be twisted in pair to minimize noise pick-up effect. The maximum line drop compensation is 0.5V.
5	-S	
4	PV-	Connect to external DC voltage source for output voltage trimming. Output voltage can be trimmed between 20 ~ 110% of the rated output voltage. Please refer to function manual for details.
6	PV+	
7	PC-	Connect to external DC voltage source for output current trimming. Output current can be trimmed between 20 ~ 100% of the rated output current. Please refer to function manual for details.
9	PC+	
8	RC-	The unit can turn the output on and off by electrical signal between RC+ and RC-. Please refer to function manual for details.
10	RC+	

■ Function Description of CN315

Pin No.	Function	Description
1	12V-AUX	Auxiliary voltage output, 11.4~12.6V, referenced to pin 3(GND-AUX). The maximum load current is 0.1A. This output is not controlled by the "remote ON/OFF control".
2	DC-OK2-GND	Open collector signal. Low when the PSU turns on. The maximum sink current is 10mA and the maximum external voltage is 20V.
4	DC-OK2	
3	GND-AUX	Auxiliary voltage output GND. The signal return is isolated from the output terminals (+V & -V).
6	AC-FAIL2-GND	Open collector signal. Low when the PSU input voltage

■ Derating Curve

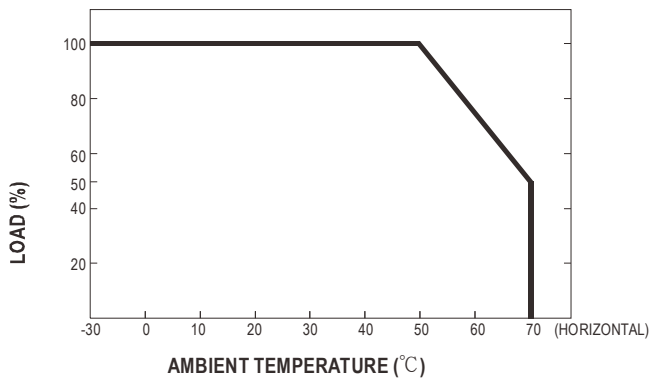

■ Static Characteristics

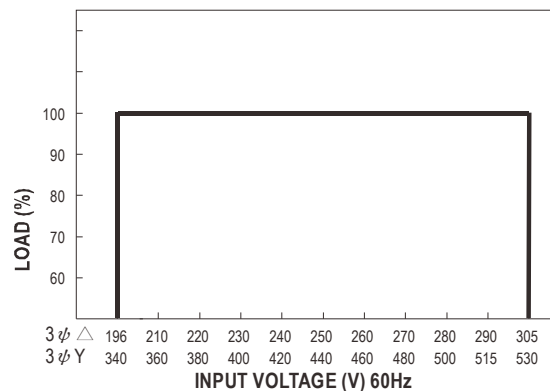

■ Function Manual

1.Remote ON/OFF Control

The PSU can be turned ON/OFF by using the "Remote ON/OFF" function.

Between ON/OFF(CN313 or CN314 pin10) and 12V-AUX(CN315 pin1)	Output Status
SW close (Short)	PSU ON
SW open (Open)	PSU OFF

Table 1.1

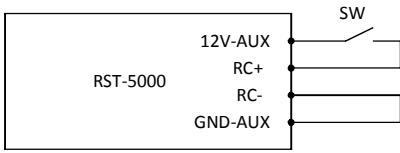

Fig 1.1

2.Remote Sense

The remote sensing compensates voltage drop on the load wiring up to 0.3V. If remote sensing is unnecessary, +S & +V, -S & -V also need to be connected directly for local sensing.

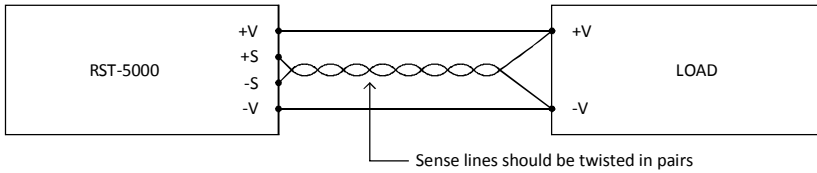

Fig 2.1

3.Output Voltage Trimming

- (1) Switch DIP-SW position-2 to upper position(ON) when AC power off.
- (2) Connecting an external DC source between PV+ and PV- on CN313 or CN314, and +S & +V, -S & -V also need to be connected that is shown in Fig 3.1.
- (3) Adjustment of output voltage is possible between 20~110%(Typ.) of the rated output which is shown in Fig 3.2.

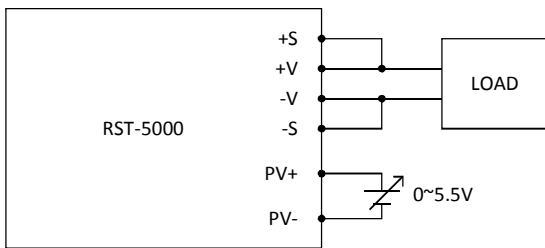

Fig 3.1

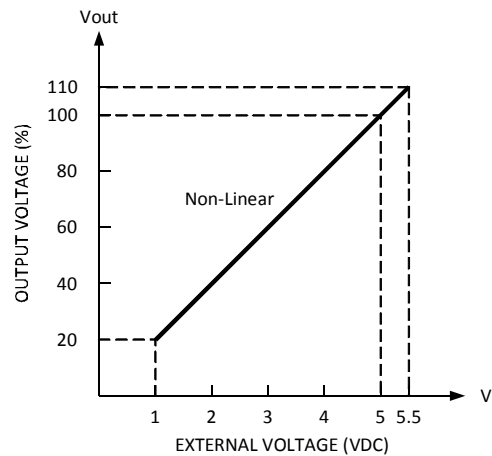

Fig 3.2

4.Output Current Trimming

- (1) Switch DIP-SW position-3 to upper position(ON) when AC power off.
- (2) Using external voltage source between PC+ and PC- on CN313 or CN314 that is shown in Fig 4.1.
- (3) Adjustment of output current is possible between 20~100%(Typ.) of its rated current which is shown in Fig 4.2.

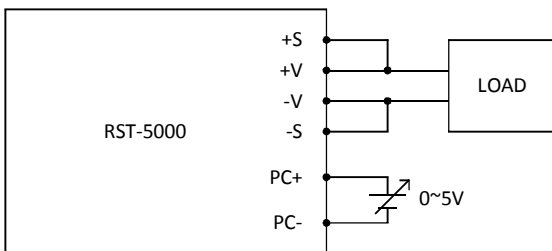

Fig 4.1

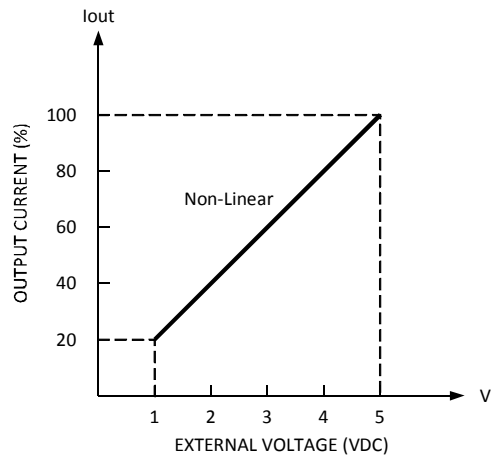

Fig 4.2

5. Select OLP mode

RST-5000 has two selectable OLP modes by switching DIP-SW position-1.

(1) Continuous Constant Current mode

RST-5000 work in constant current mode when output overload or short circuit. Switch DIP-SW position-1 to lower position(OFF) to select this mode.

(2) Delay Shutdown mode

Switch DIP-SW position-1 to upper position(ON) to select Delay Shutdown mode. When RST-5000 occur overload or short circuit, it shut off the output after 5 seconds.

6. Front Panel Indicators

LED	Description
GREEN(LED1)	LED on when output voltage is OK
RED(LED2)	LED on when any protection occurs

Table 6.1

7. Alarm Signal Output

There are 4 alarm signals on CN315, and each signal has two kind of output circuit.

(1) Relay contact output

Normally open contact. "Short" when the alarm occurs. Relay contact rating(max.) is 30V/1A resistive.

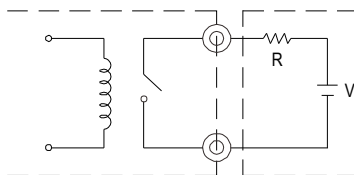

Fig 7.1

(2) Open collector output

An external voltage source is required for this function that is shown in Fig 7.2. These signals are isolated from Output. The maximum sink current is 10mA and the maximum external voltage is 20V with build-in 24V zener diode.

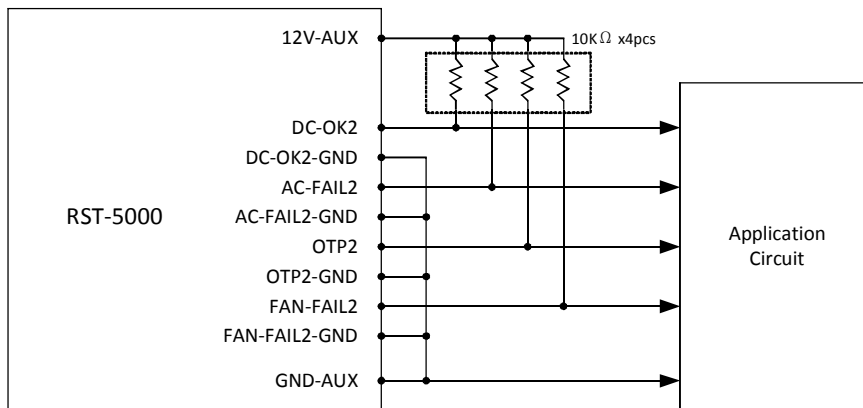

Fig 7.2

8. Current Sharing

(1) Parallel operation is available by connecting the units shown as below. (+S,-S and CS+, CS- and RC+, RC- are connected mutually in parallel)

(2) The voltage difference among each output should be minimized that less than 0.2V is required.

(3) The total output current must not exceed the value determined by the following equation.

$$(\text{Output current at parallel operation}) = (\text{The rated current per unit}) \times (\text{Number of unit}) \times 0.9$$

(4) In parallel operation 3 units is the maximum, please consult the manufacturer for other applications.

(5) When remote sensing is used in parallel operation, the sensing wire must be connected only to the master unit.

(6) Wires of remote sensing should be kept at least 30 cm from input wires.

(7) When in parallel operation, the minimum output load should be greater than 5% of total output load.

$$(\text{Min. Load}) > (5\% \text{ rated current per unit}) \times (\text{number of unit})$$

9.AC Power Connection

◎3 phase 3 wire Δ 230VAC

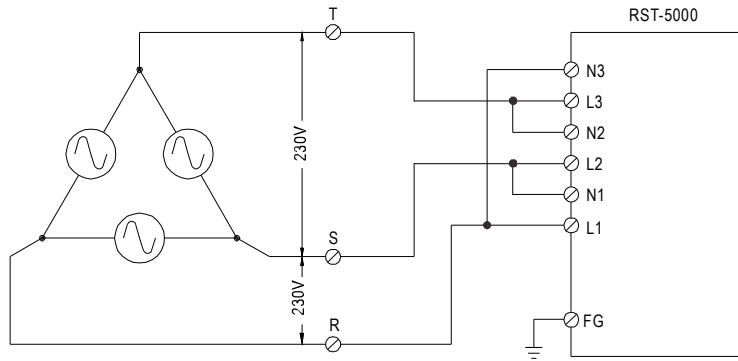

Fig 9.1

◎3 phase 4 wire Y 400VAC

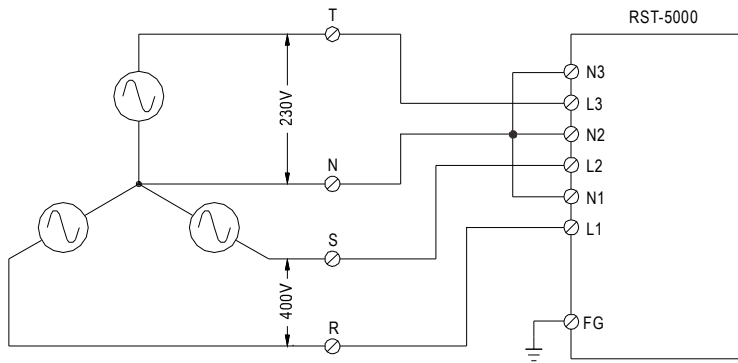

Fig 9.2

◎1 phase 2 wire 230VAC

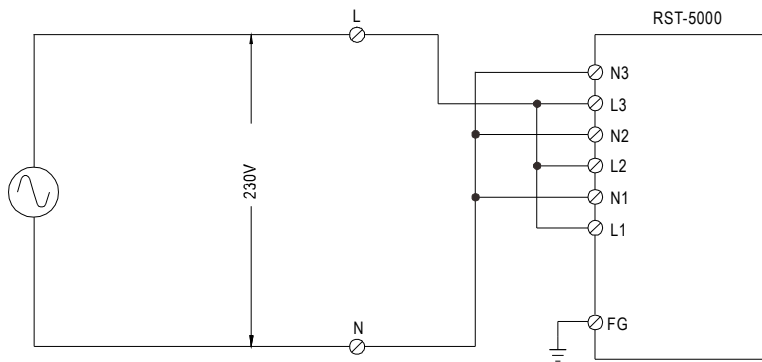

Fig 9.3