



MEAN WELL

SWITCHING POWER SUPPLY
ISO-9001 CERTIFIED MANUFACTURER

S-250 SERIES

- .LOW COST, HIGH RELIABILITY
- .105°C OUTPUT CAPACITOR
- .INTERNATIONAL AC INPUT RANGE
- .HIGH EFFICIENCY, LOW WORKING TEMPERATURE
- .SOFT-START CIRCUIT, LIMITING AC SURGE CURRENT
- .SHORT CIRCUIT, OVERLOAD PROTECTED
- .COMPACT SIZE, LIGHT WEIGHT
- .100% FULL LOAD BURN-IN TEST
- .BUILT IN EMI FILTER, LOW RIPPLE NOISE

MODEL	S-250-5	S-250-12	S-250-15	S-250-24	S-250-27	S-250-48
DC OUTPUT VOLTAGE	5V	12V	15V	24V	27V	48V
OUTPUT V. TOLERANCE	±2%	±1%	±1%	±1%	±1%	±1%
OUTPUT RATED CURRENT	40A	18A	15A	10A	9A	5.2A
OUTPUT CURRENT RANGE	0-40A	0-18A	0-15A	0-10A	0-9A	0-5.2A
RIPPLE & NOISE	80mVp-p	120mVp-p	120mVp-p	120mVp-p	150mVp-p	200mVp-p
LINE REGULATION	±0.5%	±0.5%	±0.5%	±0.5%	±0.5%	±0.5%
LOAD REGULATION	±1%	±0.5%	±0.5%	±0.5%	±0.5%	±0.5%
MAX. DC OUTPUT POWER	200W	216W	225W	240W	243W	249.6W
EFFICIENCY	75%	79%	80%	81.5%	82%	82%
DC VOLTAGE ADJ.	4.75-5.5V	10.8-13.2V	13.5-16.5V	21.6-26.4V	24.3-29.7V	43.2-52.8V
INPUT VOLTAGE RANGE	90-132VAC / 176-264VAC SELECTED BY SWITCH 47-63Hz; 248-370VDC					
AC CURRENT	6A/115V 3.5A/230V					
INRUSH CURRENT	COLD START 50A/230VAC					
LEAKAGE CURRENT	<2mA/240VAC					
OVERLOAD PROTECTION	105%-135% TYPE:PULSING HICCUP SHUTDOWN RESET:AUTO RECOVERY					
OVER VOLTAGE PROTECTION	115-135% TYPE:PLUSE BY PULSE					
TEMP. COEFFICIENT	±0.03% / °C (0-50°C)					
SETUP, RISE, HOLD UP TIME	800ms, 50ms, 16ms					
VIBRATION	10-500Hz, 2G 10min./1cycle, PERIOD FOR 60min. EACH AXES					
WITHSTAND VOLTAGE	I/P-O/P:3KVAC I/P-FG:1.5KVAC O/P-FG:0.5KVAC					
ISOLATION RESISTANCE	I/P-O/P, I/P-FG, O/P-FG:500VDC / 100M Ohms					
WORKING TEMP., HUMIDITY	-10°C~+60°C(REFER TO OUTPUT DERATING CURVE), 20%-90% RH					
STORAGE TEMP., HUMIDITY	-20°C~+85°C, 10%-95% RH					
DIMENSION	150*140*86mm CASE:907					
WEIGHT	1.3Kgs					
SAFETY STANDARDS	UL60950 APPROVED					
EMC STANDARDS	MEET EN55022 (CISPR22) CLASS B, EN50082,EN55024					

- NOTE :
- 1.ALL PARAMETERS ARE SPECIFIED AT 230VAC INPUT, RATED LOAD, 25°C 70% RH. AMBIENT.
 - 2.TOLERANCE : INCLUDE SET UP TOLERANCE, LINE REGULATION, LOAD REGULATION.
 - 3.RIPPLE & NOISE ARE MEASURED AT 20MHz BY USING A 12" TWISTED PAIR TERMINATED WITH A 0.1uF & 47uF CAPACITOR.
 - 4.LINE REGULATION IS MEASURED FROM LOW LINE TO HIGH LINE AT RATED LOAD.
 - 5.LOAD REGULATION IS MEASURED FROM 0% TO 100% RATED LOAD.

BLOCK DIAGRAM

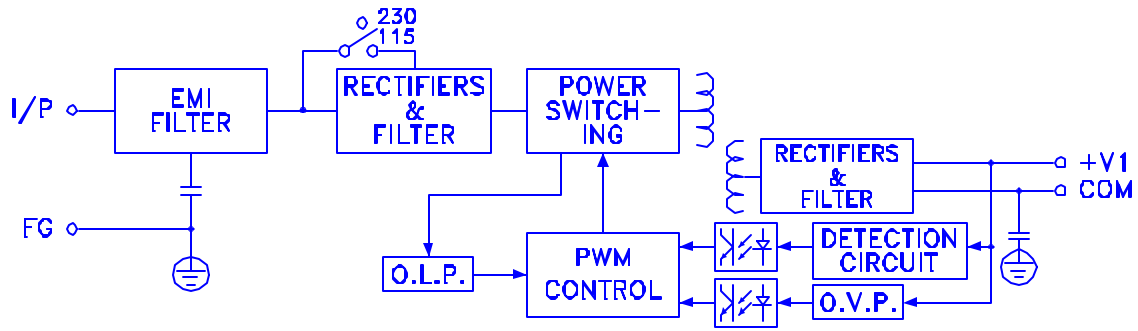

fosc: 70KHz

OUTPUT DERATING

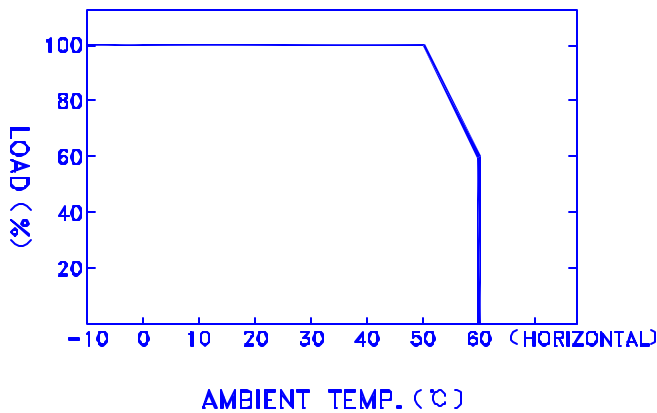

OUTPUT DERATING VS INPUT VOLTAGE

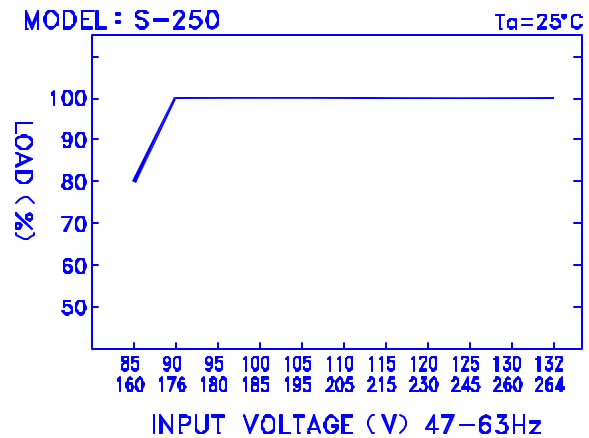

DIMENSION (mm)

- ☒ CASE : 907
- ☒ TERMINAL PIN NO. ASSIGNMENT
 - ☒ PIN 1,2 : AC INPUT
 - ☒ PIN 3 : FG \perp
 - ☒ PIN 4,5,6 : DC OUTPUT COM
 - ☒ PIN 7,8,9 : DC OUTPUT V1

