

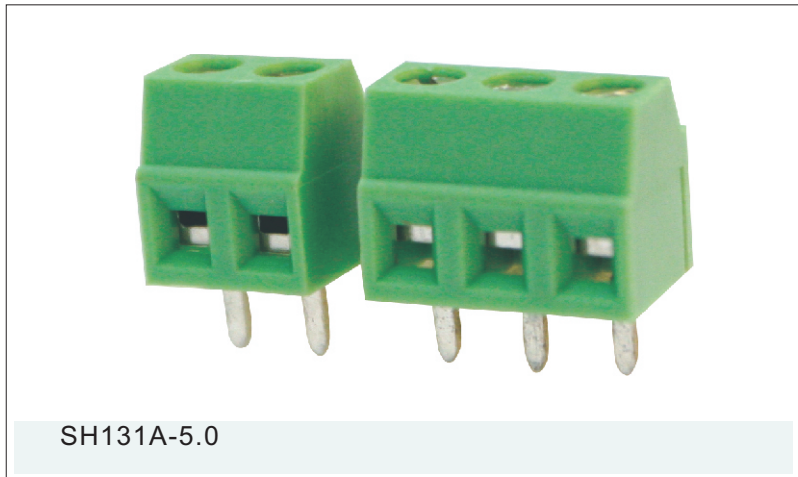

慈溪三和电器塑料有限公司

CIXI SANHE APPLIANCE & PLASTICS CO., LTD.

产品规格书



认证		
电气性能		
参考标准	UL	IEC
额定电压	300V	250V
额定电流	10A	15A
使用线径	22-16AWG	1.5mm ²
耐电压	AC2000V/Min	
机械性能		
温度范围	-40℃~+105℃	
剥线长度	5-6mm	
扭力	3.0kgf.cm	
尺寸		
间距	5.0mm	
极数	2P 3P	
材质及电镀		
塑件	Pa66 UL94V-0	
焊脚	黄铜 镀锡	
弹片	磷铜 镀镍	
螺丝	M2.5 铁 镀镍	

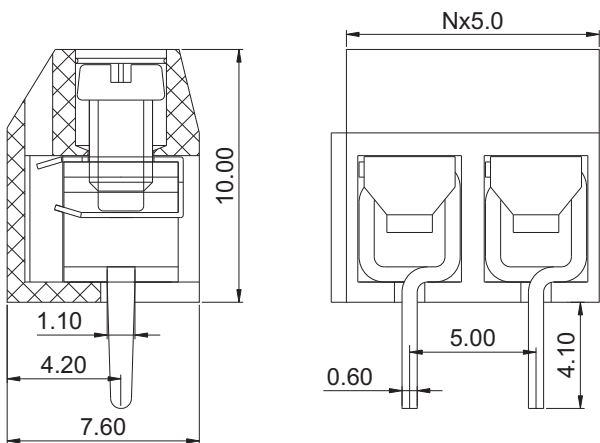

订购方式:

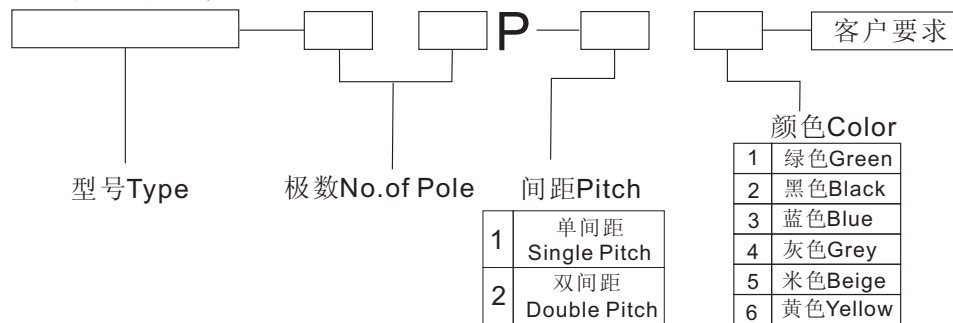

MM (INCH) 慈溪三和电器塑料有限公司 CIXI SANHE APPLIANCE & PLASTICS CO., LTD.

THIRD ANGLE PROJECTION NAME SH131A-5.0