



CAN TRANSCEIVER

FEATURES

- Drop-In Improved Replacement for the PCA82C250 and PCA82C251
- Bus-Fault Protection of ± 36 V
- Meets or Exceeds ISO 11898
- Signaling Rates⁽¹⁾ up to 1 Mbps
- High Input Impedance Allows up to 120 SN65HVD251 Nodes on a Bus
- Bus Pin ESD Protection Exceeds 14 kV HBM
- Unpowered Node Does Not Disturb the Bus
- Low Current Standby Mode . . . 200 μ A Typical
- Thermal Shutdown Protection

- Glitch-Free Power-Up and Power-Down Bus Protection For Hot-Plugging
- DeviceNet Vendor ID # 806

APPLICATIONS

- CAN Data Buses
- Industrial Automation
 - DeviceNet™ Data Buses
 - Smart Distributed Systems (SDS™)
- SAE J1939 Standard Data Bus Interface
- NMEA 2000 Standard Data Bus Interface
- ISO 11783 Standard Data Bus Interface

DESCRIPTION

The SN65HVD251 is intended for use in applications employing the Controller Area Network (CAN) serial communication physical layer in accordance with the ISO 11898 Standard. The SN65HVD251 provides differential transmit capability to the bus and differential receive capability to a CAN controller at speeds up to 1 megabits per second (Mbps).

Designed for operation in harsh environments, the device features cross-wire, over-voltage and loss of ground protection to ± 36 V. Also featured are over-temperature protection as well as -7 V to 12 V common-mode range, and tolerance to transients of ± 200 V. The transceiver interfaces the single-ended CAN controller with the differential CAN bus found in industrial, building automation, and automotive applications.

Rs, pin 8, provides for three different modes of operation: high-speed, slope control, or low-power mode. The high-speed mode of operation is selected by connecting pin 8 to ground, allowing the transmitter output transistors to switch as fast as possible with no limitation on the rise and fall slope. The rise and fall slope can be adjusted by connecting a resistor to ground at pin 8; the slope is proportional to the pin's output current. Slope control with an external resistor value of 10 k Ω gives ~ 15 V/us slew rate; 100 k Ω gives ~ 2 V/us slew rate.

If a high logic level is applied to the Rs pin 8, the device enters a low-current standby mode during which the driver is switched off and the receiver remains active. The local protocol controller reverses this low-current standby mode when it needs to transmit to the bus.

The SN65HVD251 may be used in CAN, DeviceNet™ or SDS™ applications with the Texas Instruments' TMS320F241 and TMS320F243 DSPs with CAN 2.0B controllers.

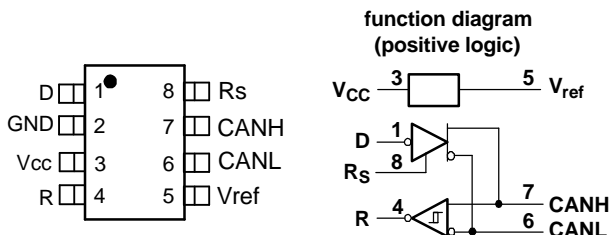

⁽¹⁾The signaling rate of a line is the number of voltage transitions that are made per second expressed in the units bps (bits per second).



Please be aware that an important notice concerning availability, standard warranty, and use in critical applications of Texas Instruments semiconductor products and disclaimers thereto appears at the end of this data sheet.

DeviceNet is a trademark of Allen-Bradley.
SDS is a trademark of Honeywell.

ORDERING INFORMATION

PART NUMBER	PACKAGE	MARKED AS
SN65HVD251D	8-pin SOIC (Tube)	VP251
SN65HVD251DR	8-pin SOIC (Tape & Reel)	VP251
SN65HVD251P	8-pin DIP	65HVD251

ABSOLUTE MAXIMUM RATINGS^{(1), (2)}

			SN65HVD251
Supply voltage range, V_{CC}			-0.3 V to 7V
Voltage range at any bus terminal (CANH or CANL)			-36 V to 36 V
Transient voltage per ISO 7637, pulse 1, 2, 3a, 3b		CANH, CANL	± 200 V
Input voltage range, V_I (D, Rs, or R)			-0.3 V to $V_{CC} + 0.5$
Electrostatic discharge	Human Body Model ⁽³⁾	CANH, CANL and GND	14 kV
		All pins	6 kV
	Charged-Device Model ⁽⁴⁾	All pins	1 kV
Continuous total power dissipation			(see Dissipation Rating Table)
Storage temperature range, T_{stg}			-65°C to 150°C
Lead temperature 1,6 mm (1/16 inch) from case for 10 seconds			260°C

- (1) Stresses beyond those listed under "absolute maximum ratings" may cause permanent damage to the device. These are stress ratings only and functional operation of the device at these or any other conditions beyond those indicated under "recommended operating conditions" is not implied. Exposure to absolute-maximum-rated conditions for extended periods may affect device reliability.
- (2) All voltage values, except differential I/O bus voltages, are with respect to network ground terminal.
- (3) Tested in accordance with JEDEC Standard 22, Test Method A114-A.
- (4) Tested in accordance with JEDEC Standard 22, Test Method C101.

ABSOLUTE MAXIMUM POWER DISSIPATION RATINGS

PACKAGE	CIRCUIT BOARD MODEL	$T_A = 25^\circ\text{C}$ POWER RATING	DERATING FACTOR ⁽¹⁾ ABOVE $T_A = 25^\circ\text{C}$	$T_A = 85^\circ\text{C}$ POWER RATING	$T_A = 125^\circ\text{C}$ POWER RATING
SOIC (D)	Low-K ⁽²⁾	600 mW	4.4 mW/°C	312 mW	120 mW
	High-K ⁽³⁾	963 mW	7.7 mW/°C	501 mW	193 mW
PDIP (P)	Low-K ⁽²⁾	984 mW	7.8 mW/°C	512 mW	197 mW
	High-K ⁽³⁾	1344 mW	10.8 mW/°C	699 mW	269 mW

- (1) This is the inverse of the junction-to-ambient thermal resistance when board-mounted and with no air flow.
- (2) In accordance with the Low-K thermal metric definitions of EIA/JESD51-3.
- (3) In accordance with the High-K thermal metric definitions of EIA/JESD51-7.

THERMAL CHARACTERISTICS

PARAMETER	TEST CONDITIONS	VALUE			UNITS
		MIN	TYP	MAX	
Θ_{JB} Junction-to-board thermal resistance	D		78.7		°C/W
	P		56.5		
Θ_{JC} Junction-to-board thermal resistance	D		44.6		°C/W
	P		54.5		
P_D Device power dissipation	$V_{CC} = 5$ V, $T_j = 27^\circ\text{C}$, $R_L = 60\Omega$, R_S at 0 V, Input to D a 500-kHz 50% duty cycle square wave		97.7		mW
	$V_{CC} = 5.5$ V, $T_j = 130^\circ\text{C}$, $R_L = 60\Omega$, R_S at 0 V, Input to D a 500-kHz 50% duty cycle square wave			142	
T_{SD} Thermal shutdown junction temperature			165		°C

RECOMMENDED OPERATING CONDITIONS

over recommended operating conditions (unless otherwise noted).

PARAMETER		MIN	NOM	MAX	UNIT
Supply voltage, V_{CC}		4.5		5.5	V
Voltage at any bus terminal (separately or common mode) V_I or V_{IC}		-7 ⁽¹⁾		12	V
High-level input voltage, V_{IH}	D input	0.7 V_{CC}			V
Low-level input voltage, V_{IL}	D input			0.3 V_{CC}	V
Differential input voltage, V_{ID}		-6		6	V
Input voltage to R_s , $V_{I(Rs)}$		0		V_{CC}	V
Input voltage at R_s for standby, $V_{I(Rs)}$		0.75 V_{CC}		V_{CC}	V
R_s wave-shaping resistance		0		100	k Ω
High-level output current, I_{OH}	Driver	-50			mA
	Receiver	-4			
Low-level output current, I_{OL}	Driver			50	mA
	Receiver			4	
Operating free-air temperature, T_A		-40		125	$^{\circ}$ C
Junction temperature, T_j	PDIP Package			145	$^{\circ}$ C
	SOIC Package			150	

(1) The algebraic convention, in which the least positive (most negative) limit is designated as minimum is used in this data sheet.

DRIVER ELECTRICAL CHARACTERISTICS

over recommended operating conditions (unless otherwise noted).

PARAMETER		TEST CONDITIONS	MIN	TYP ⁽¹⁾	MAX	UNIT
$V_{O(D)}$	Bus output voltage (Dominant)	CANH	Figure 1 & Figure 2 , D at 0 V R_s at 0 V		2.75	V
		CANL	0.5	3.5	4.5	
$V_{O(R)}$	Bus output voltage (Recessive)	CANH	Figure 1 & Figure 2 , D at 0.7 V_{CC} , R_s at 0 V		2	V
		CANL	2	2.5	3	
$V_{OD(D)}$	Differential output voltage (Dominant)	Figure 1 , D at 0 V , R_s at 0 V	1.5	2	3	V
$V_{OD(D)}$	Differential output voltage (Dominant)	Figure 2 & Figure 3 , D at 0 V , R_s at 0 V	1.2	2	3.1	V
$V_{OD(R)}$	Differential output voltage (Recessive)	Figure 1 & Figure 2 , D at 0.7 V_{CC}	-120		12	mV
$V_{OD(R)}$	Differential output voltage (Recessive)	D at 0.7 V_{CC} , no load	-0.5		0.05	V
$V_{OC(pp)}$	Peak-to-peak common-mode output voltage	Figure 9, R_s at 0 V		600		mV
I_{IH}	High-level input current, D Input	D at 0.7 V_{CC}	-40		0	μ A
I_{IL}	Low-level input current, D Input	D at 0.3 V_{CC}	-60		0	μ A
$I_{OS(SS)}$	Short-circuit steady-state output current	Figure 11, V_{CANH} at -7 V, CANL Open	-200			mA
		Figure 11, V_{CANH} at 12 V, CANL Open			2.5	
		Figure 11, V_{CANL} at -7 V, CANH Open	-2			
		Figure 11, V_{CANL} at 12 V, CANH Open			200	
C_O	Output capacitance	See receiver input capacitance				
I_{OZ}	High-impedance output current	See receiver input current				
$I_{IRs(s)}$	R_s input current for standby	R_s at 0.75 V_{CC}	-10			μ A
$I_{IRs(f)}$	R_s input current for full speed operation	R_s at 0 V	-550		0	μ A

(1) All typical values are at 25 $^{\circ}$ C and with a 5-V supply.

DRIVER ELECTRICAL CHARACTERISTICS (continued)

over recommended operating conditions (unless otherwise noted).

PARAMETER		TEST CONDITIONS	MIN	TYP ⁽¹⁾	MAX	UNIT	
I_{CC}	Supply current	Standby			275	μ A	
		Dominant	Rs at V_{CC} , D at V_{CC}			65	mA
		Recessive	D at 0 V, 60 Ω load, Rs at 0 V			14	

DRIVER SWITCHING CHARACTERISTICS

over recommended operating conditions (unless otherwise noted).

PARAMETER		TEST CONDITIONS	MIN	TYP	MAX	UNIT
t_{pLH}	Propagation delay time, low-to-high-level output	Figure 4, Rs at 0 V		40	70	ns
		Figure 4, Rs with 10 k Ω to ground		90	125	
		Figure 4, Rs with 100 k Ω to ground		500	800	
t_{pHL}	Propagation delay time, high-to-low-level output	Figure 4, Rs at 0 V		85	125	
		Figure 4, Rs with 10 k Ω to ground		200	260	
		Figure 4, Rs with 100 k Ω to ground		1150	1450	
$t_{sk(p)}$	Pulse skew ($ t_{pHL} - t_{pLH} $)	Figure 4, Rs at 0 V		45	85	
		Figure 4, Rs with 10 k Ω to ground		110	180	
		Figure 4, Rs with 100 k Ω to ground		650	900	
t_r	Differential output signal rise time	Figure 4, Rs at 0 V	35		100	
t_f	Differential output signal fall time		35		100	
t_r	Differential output signal rise time	Figure 4, Rs with 10 k Ω to ground	100		250	
t_f	Differential output signal fall time		100		250	
t_r	Differential output signal rise time	Figure 4, Rs with 100 k Ω to ground	600		1550	
t_f	Differential output signal fall time		600		1550	
t_{en}	Enable time from standby to dominant	Figure 8			0.5	μ s

RECEIVER ELECTRICAL CHARACTERISTICS

over recommended operating conditions (unless otherwise noted).

PARAMETER		TEST CONDITIONS	MIN	TYP	MAX	UNIT
V_{IT+}	Positive-going input threshold voltage	Rs at 0 V, (See Table 1)		750	900	mV
V_{IT-}	Negative-going input threshold voltage		500	650		
V_{hys}	Hysteresis voltage ($V_{IT+} - V_{IT-}$)		100			
V_{OH}	High-level output voltage	Figure 6, $I_O = -4$ mA	0.8 V_{CC}			V
V_{OL}	Low-level output voltage	Figure 6, $I_O = 4$ mA			0.2 V_{CC}	V
I_I	Bus input current	CANH or CANL at 12 V			600	μ A
		CANH or CANL at 12 V, V_{CC} at 0 V	Other bus pin at 0 V, Rs at 0 V, D at 0.7 V_{CC}		715	
		CANH or CANL at -7 V		-460		
		CANH or CANL at -7 V, V_{CC} at 0 V		-340		
C_I	Input capacitance, (CANH or CANL)	Pin-to-ground, $V_I = 0.4 \sin(4E6\pi t) + 0.5$ V, D at 0.7 V_{CC}			20	
C_{ID}	Differential input capacitance	Pin-to-pin, $V_I = 0.4 \sin(4E6\pi t) + 0.5$ V, D at 0.7 V_{CC}		10		pF
R_{ID}	Differential input resistance	D at 0.7 V_{CC} , Rs at 0 V	40		100	k Ω
R_{IN}	Input resistance, (CANH or CANL)	D at 0.7 V_{CC} , Rs at 0 V	20		50	k Ω

RECEIVER ELECTRICAL CHARACTERISTICS (continued)

over recommended operating conditions (unless otherwise noted).

PARAMETER		TEST CONDITIONS	MIN	TYP	MAX	UNIT
I_{CC}	Supply current	Standby			275	μA
		Dominant			65	mA
		Recessive			14	

RECEIVER SWITCHING CHARACTERISTICS

over recommended operating conditions (unless otherwise noted).

PARAMETER		TEST CONDITIONS	MIN	TYP	MAX	UNIT
t_{pLH}	Propagation delay time, low-to-high-level output	Figure 6		35	50	ns
t_{pHL}	Propagation delay time, high-to-low-level output			35	50	
$t_{sk(p)}$	Pulse skew ($ t_{pHL} - t_{pLH} $)				20	
t_r	Output signal rise time			2	4	
t_f	Output signal fall time			2	4	
$t_{p(sb)}$	Propagation delay time in standby		Figure 12, R_s at V_{CC}			

VREF-PIN CHARACTERISTICS

over recommended operating conditions (unless otherwise noted).

PARAMETER		TEST CONDITIONS	MIN	TYP	MAX	UNIT
V_O	Reference output voltage	$-5 \mu\text{A} < I_O < 5 \mu\text{A}$	$0.45 V_{CC}$		$0.55 V_{CC}$	V
		$-50 \mu\text{A} < I_O < 50 \mu\text{A}$	$0.4 V_{CC}$		$0.6 V_{CC}$	

DEVICE SWITCHING CHARACTERISTICS

over recommended operating conditions (unless otherwise noted).

PARAMETER	TEST CONDITIONS	MIN	TYP	MAX	UNIT
t_{loop1}	Figure 10, R_s at 0 V		60	100	ns
	Figure 10, R_s with 10 k Ω to ground		100	150	
	Figure 10, R_s with 100 k Ω to ground		440	800	
t_{loop2}	Figure 10, R_s at 0 V		115	150	ns
	Figure 10, R_s with 10 k Ω to ground		235	290	
	Figure 10, R_s with 100 k Ω to ground		1070	1450	
t_{loop2}	Figure 10, R_s at 0 V, V_{CC} from 4.5 V to 5.1 V,		105	145	ns

PARAMETER MEASUREMENT INFORMATION

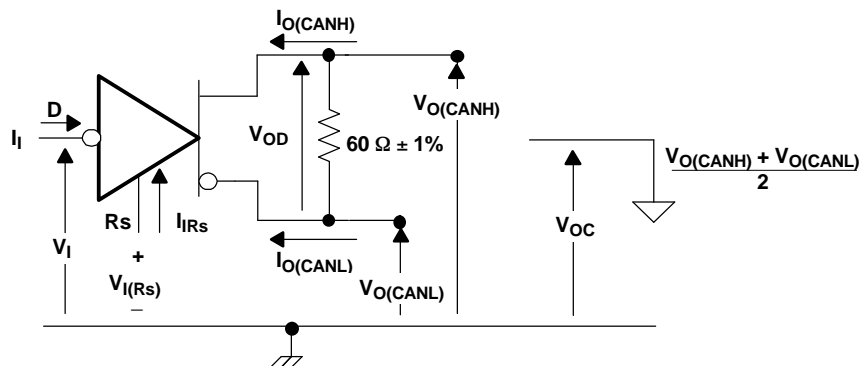

Figure 1. Driver Voltage, Current, and Test Definition

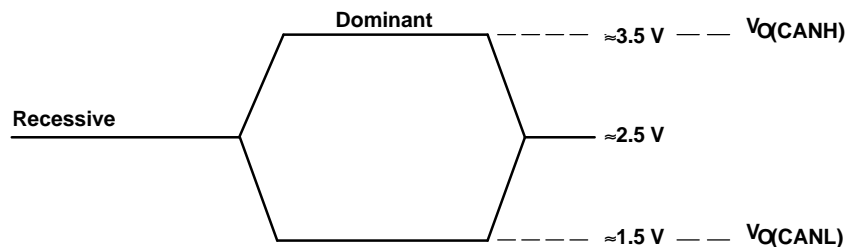

Figure 2. Bus Logic State Voltage Definitions

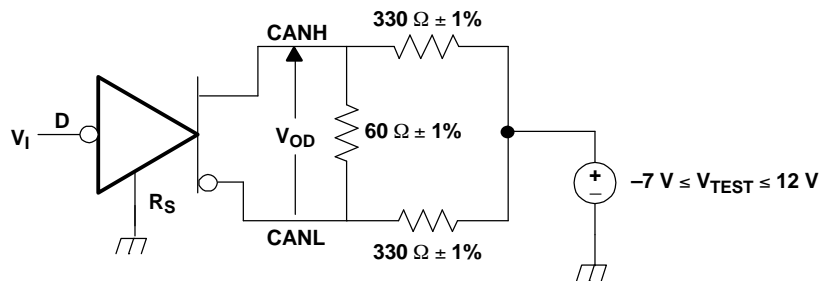

Figure 3. Driver V_{OD}

PARAMETER MEASUREMENT INFORMATION (continued)

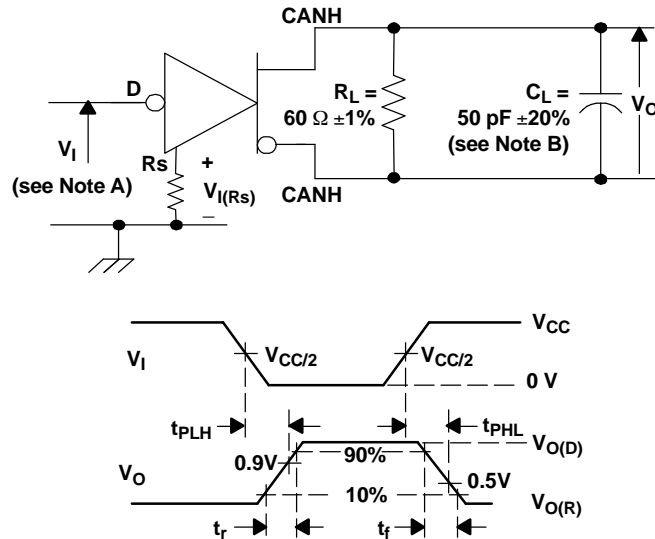

Figure 4. Driver Test Circuit and Voltage Waveforms

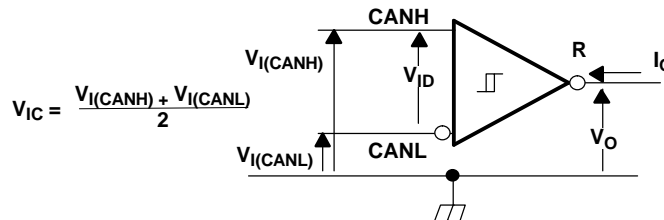
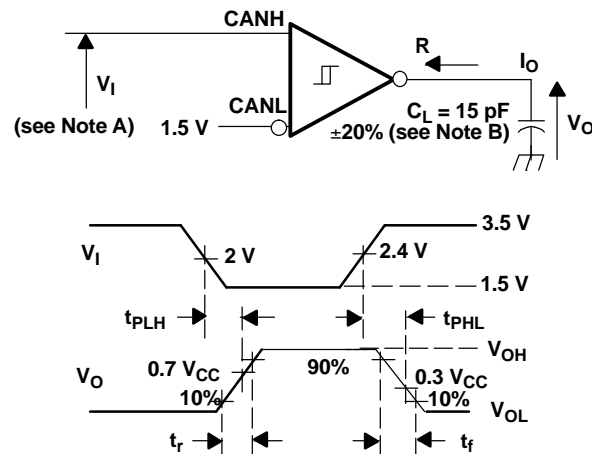

Figure 5. Receiver Voltage and Current Definitions



- A. The input pulse is supplied by a generator having the following characteristics: PRR ≤ 125 kHz, 50% duty cycle, $t_r \leq 6\text{ns}$, $t_f \leq 6\text{ns}$, $Z_O = 50\Omega$.
- B. C_L includes instrumentation and fixture capacitance within ±20%.

Figure 6. Receiver Test Circuit and Voltage Waveforms

PARAMETER MEASUREMENT INFORMATION (continued)

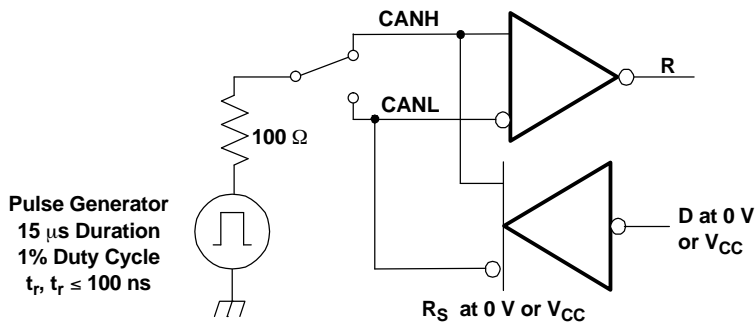

C. This test is conducted to test survivability only. Data stability at the R output is not specified.

Figure 7. Test Circuit, Transient Over-Voltage Test

Table 1. Receiver Characteristics Over Common Mode Voltage

INPUT		MEASURED	OUTPUT	
V_{CANH}	V_{CANL}	$ V_{ID} $	R	
12 V	11.1 V	900 mV	L	V_{OL}
-6.1 V	-7 V	900 mV	L	
-1 V	-7 V	6 V	L	
12 V	6 V	6 V	L	
-6.5 V	-7 V	500 mV	H	V_{OH}
12 V	11.5 V	500 mV	H	
-7 V	-1 V	6 V	H	
6 V	12 V	6 V	H	
open	open	X	H	

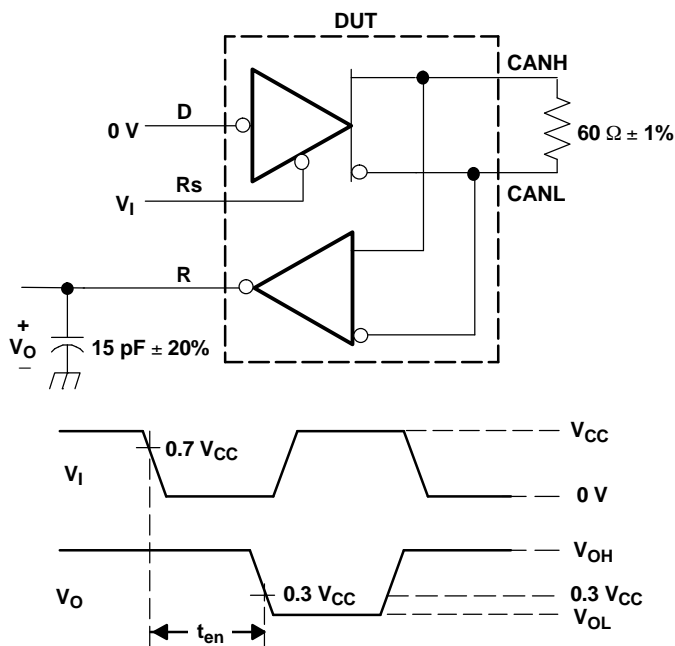
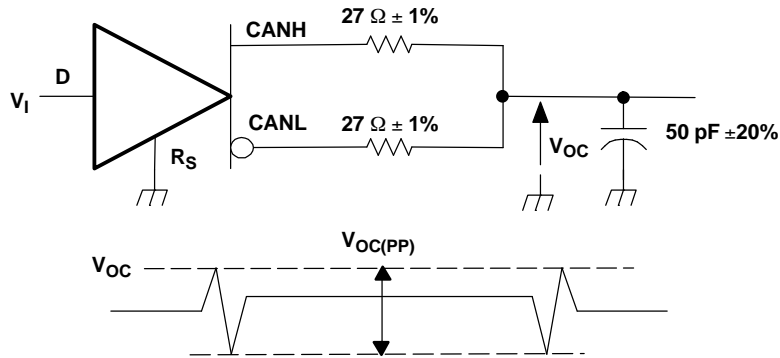

Figure 8. t_{en} Test Circuit and Voltage Waveforms

DEVICE SWITCHING CHARACTERISTICS (continued)



- A. The input pulse is supplied by a generator having the following characteristics: PRR \leq 125 kHz, 50% duty cycle, $t_r \leq$ 6ns, $t_f \leq$ 6ns, $Z_O = 50\Omega$.

Figure 9. Peak-to-Peak Common Mode Output Voltage

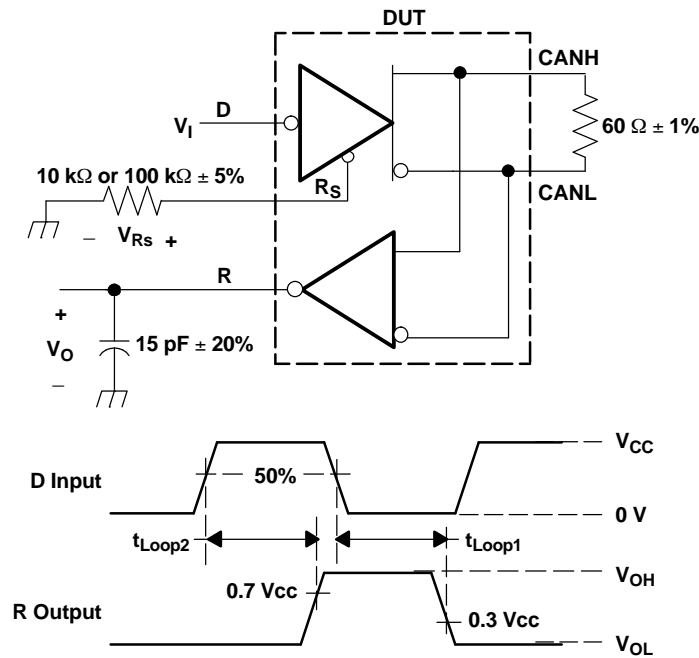

Figure 10. t_{LOOP} Test Circuit and Voltage Waveforms

DEVICE SWITCHING CHARACTERISTICS (continued)

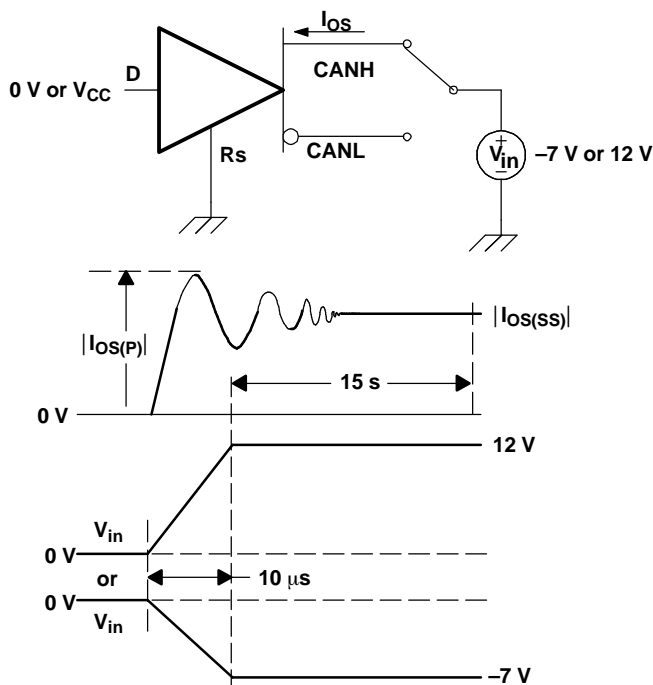
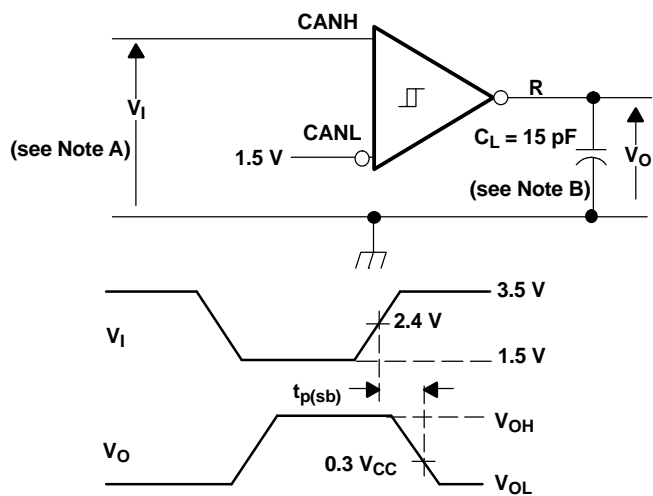

Figure 11. Driver Short-Circuit Test



- B. The input pulse is supplied by a generator having the following characteristics: PRR ≤ 125 kHz, 50% duty cycle, $t_r \leq 6\text{ns}$, $t_f \leq 6\text{ns}$, $Z_O = 50\Omega$.
- C. C_L includes instrumentation and fixture capacitance within $\pm 20\%$.

Figure 12. Receiver Propagation Delay in Standby Test Circuit and Waveform

DEVICE INFORMATION

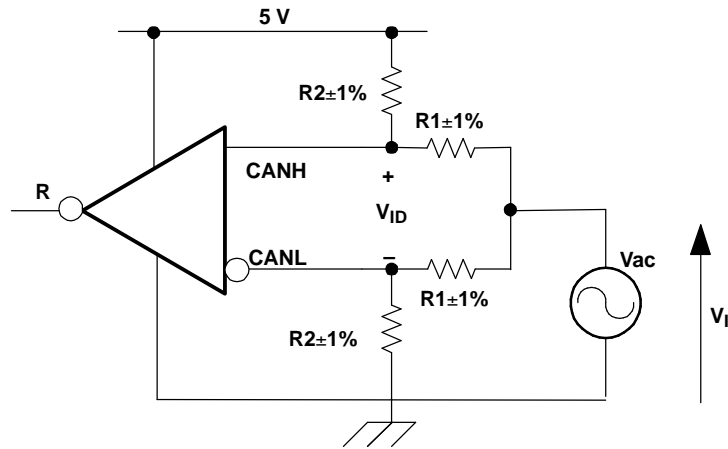

V_{ID}	R1	R2
500 mV	50 Ω	450 Ω
900 mV	50 Ω	227 Ω



A. All input pulses are supplied by a generator having the following characteristics: $f < 1.5$ MHz, $T_A = 25^\circ\text{C}$, $V_{CC} = 5.0$ V.

Figure 13. Common-Mode Input Voltage Rejection Test

FUNCTION TABLES

Table 2. DRIVER

INPUTS	Voltage at R_S , V_{RS}	OUTPUTS		BUS STATE
		CANH	CANL	
D				
L	$V_{RS} < 1.2$ V	H	L	Dominant
H	$V_{RS} < 1.2$ V	Z	Z	Recessive
Open	X	Z	Z	Recessive
X	$V_{RS} > 0.75 V_{CC}$	Z	Z	Recessive

Table 3. RECEIVER

DIFFERENTIAL INPUTS [$V_{ID} = V(\text{CANH}) - V(\text{CANL})$]	OUTPUT R ⁽¹⁾
$V_{ID} \geq 0.9$ V	L
$0.5\text{V} < V_{ID} < 0.9$ V	?
$V_{ID} \leq 0.5$ V	H
Open	H

(1) H = high level; L = low level; X = irrelevant; ? = indeterminate; Z = high impedance

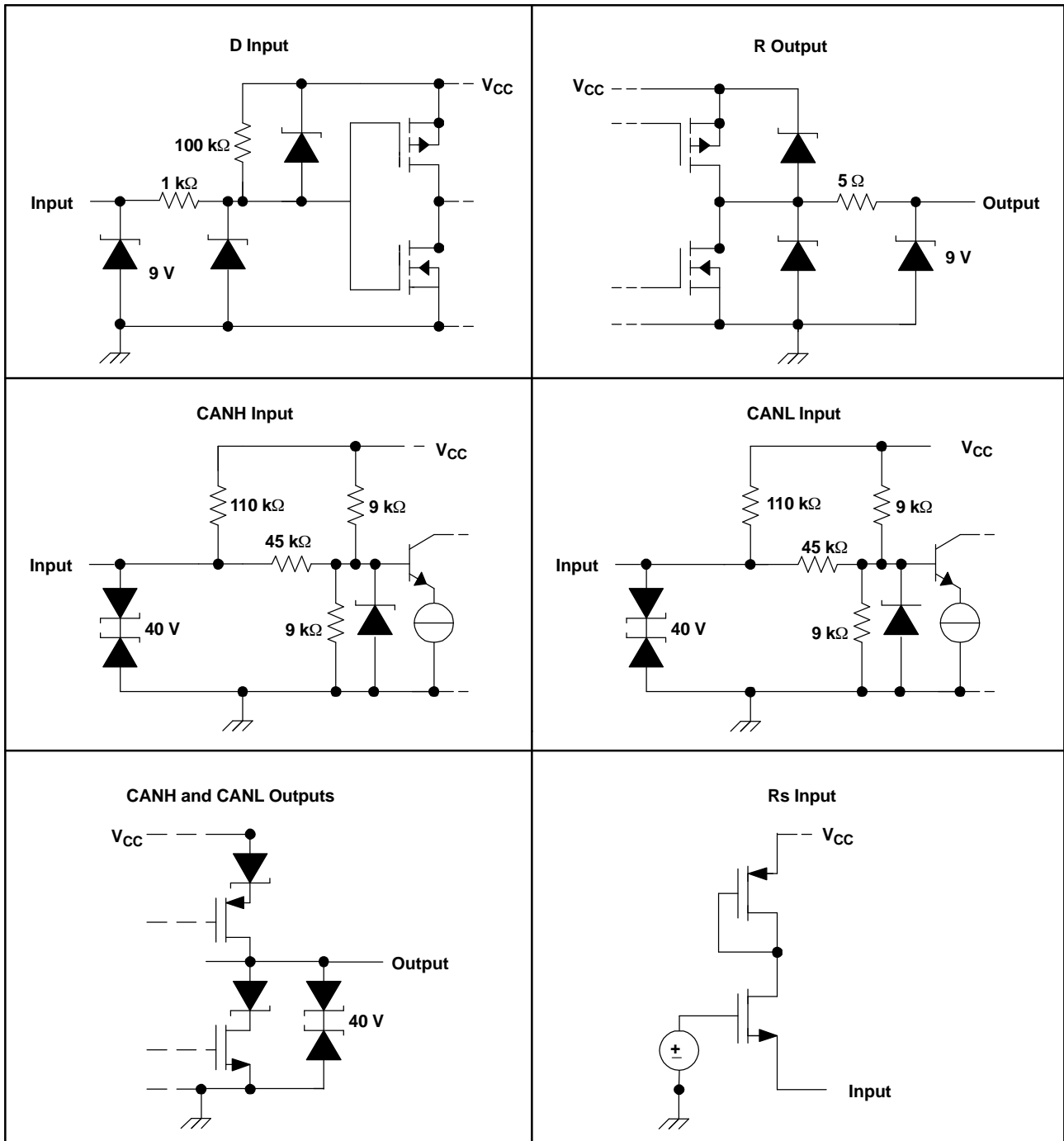

Figure 14. Equivalent Input and Output Schematic Diagrams

TYPICAL CHARACTERISTICS

**t_{LOOP1}-LOOP TIME
VS
FREE-AIR TEMPERATURE**

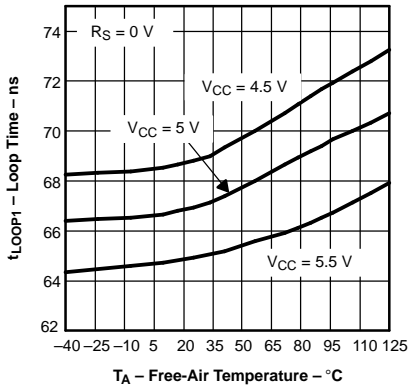

Figure 15.

**t_{LOOP2}-LOOP TIME
VS
FREE-AIR TEMPERATURE**

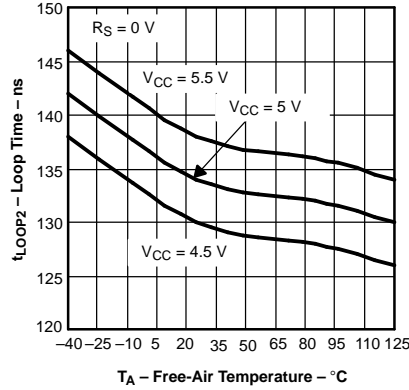

Figure 16.

**SUPPLY CURRENT (RMS)
VS
SIGNALING RATE**

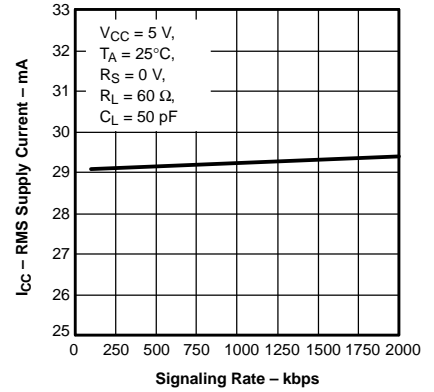

Figure 17.

**DRIVER LOW-LEVEL OUTPUT CURRENT
VS
LOW-LEVEL OUTPUT VOLTAGE**

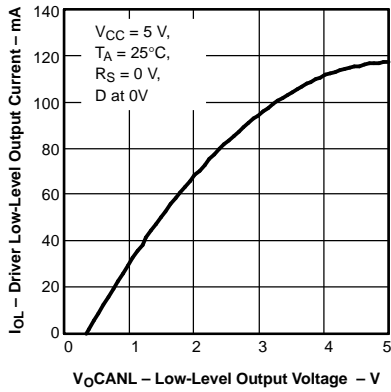

Figure 18.

**DRIVER HIGH-LEVEL OUTPUT CURRENT
VS
HIGH-LEVEL OUTPUT VOLTAGE**

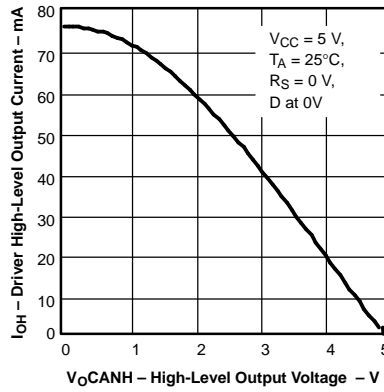

Figure 19.

**DOMINANT DIFFERENTIAL OUTPUT VOLTAGE
VS
FREE-AIR TEMPERATURE**

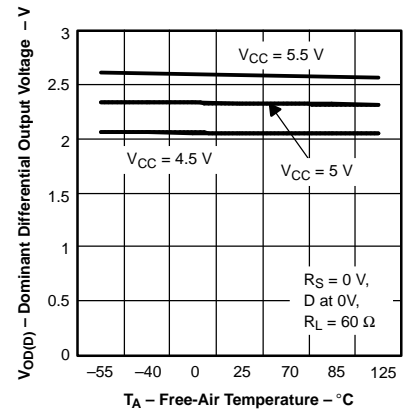
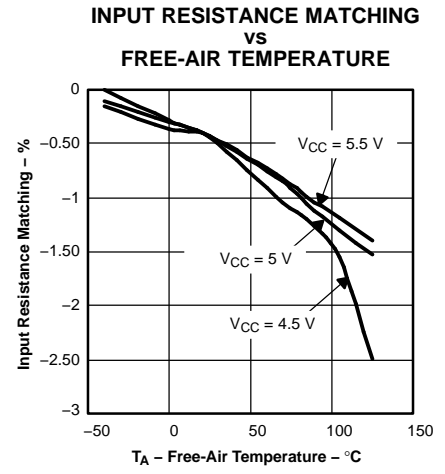
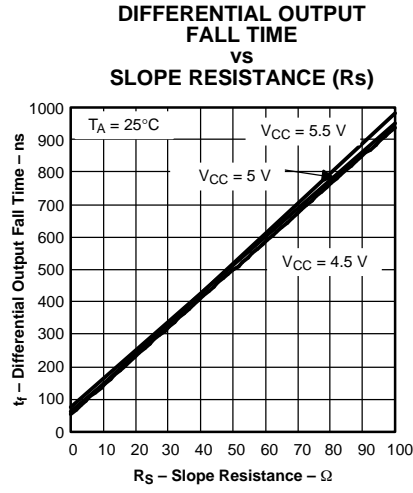
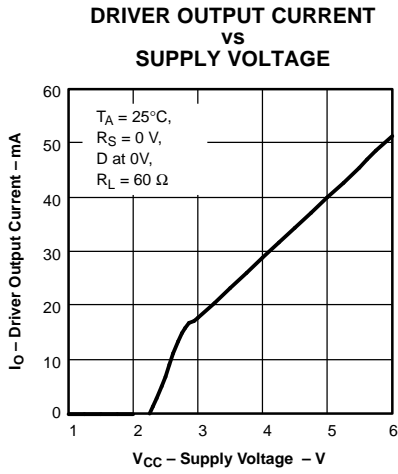

Figure 20.



APPLICATION INFORMATION

The basics of arbitration require that the receiver at the sending node designate the first bit as dominant or recessive after the initial wave of the first bit of a message travels to the most remote node on a network and back again. Typically, this *sample* is made at 75% of the bit width, and within this limitation, the maximum allowable signal distortion in a CAN network is determined by network electrical parameters.

Factors to be considered in network design include the ≈ 5 ns/m propagation delay of typical twisted-pair bus cable; signal amplitude loss due to the loss mechanisms of the cable; and the number, length, and spacing of drop-lines (stubs) on a network. Under strict analysis, variations among the different oscil-

lators in a system also need to be accounted for with adjustments in signaling rate and stub & bus length. Table 2 lists the maximum signaling rates achieved with the SN65HVD251 in high-speed mode with several bus lengths of category 5, shielded twisted pair (CAT 5 STP) cable.

Table 4. Maximum Signaling Rates for Various Cable Lengths

BUS LENGTH (m)	SIGNALING RATE (kbps)
30	1000
100	500
250	250
500	125
1000	62.5

The ISO 11898 Standard specifies a maximum bus length of 40 m and maximum stub length of 0.3 m with a maximum of 30 nodes. However, with careful design, users can have longer cables, longer stub lengths, and many more nodes on a bus. (Note: Non-standard application may come with a trade-off in signaling rate.) A large number of nodes requires a transceiver with high input impedance such as the HVD251.

The Standard specifies the interconnect to be a single twisted-pair cable (shielded or unshielded) with 120Ω characteristic impedance (Z_0). Resistors equal to the characteristic impedance of the line terminate both ends of the cable to prevent signal reflections. Unterminated drop-lines connect nodes to the bus and should be kept as short as possible to minimize signal reflections.

Connectors, while not specified by the Standard should have as little effect as possible on standard operating parameters such as capacitive loading. Although unshielded cable is used in many applications, data transmission circuits employing CAN transceivers are usually used in applications requiring a rugged interconnection with a wide common-mode voltage range. Therefore, shielded cable is recommended in these electronically harsh environments, and when coupled with the Standard's -2 -V to 7 -V common-mode range of tolerable ground noise, helps to ensure data integrity. The HVD251 enhances the Standard's insurance of data integrity with an extended -7 -V to 12 -V range of common-mode operation.

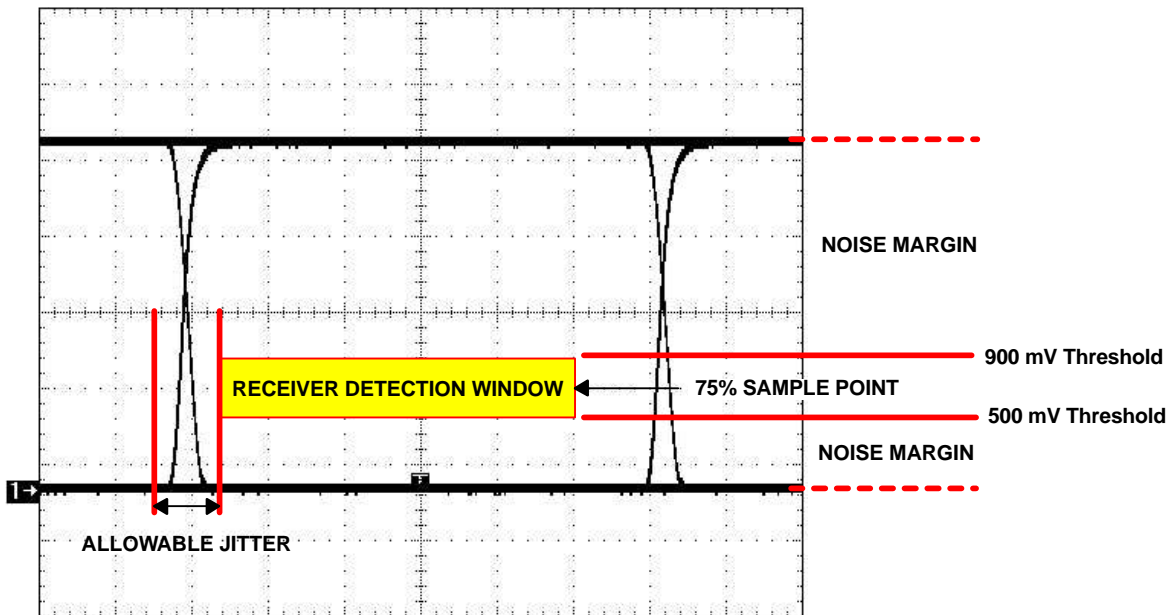

Figure 24. Typical CAN Differential Signal Eye-Pattern

An eye pattern is a useful tool for measuring overall signal quality. As displayed in Figure 24, the differential signal changes logic states in two places on the display, producing an eye. Instead of viewing only one logic crossing on the scope, an entire *bit* of data is brought into view. The resulting eye pattern includes all of the effects of systemic and random distortion, and displays the time during which a signal may be considered valid.

The height of the eye above or below the receiver threshold voltage level at the sampling point is the noise margin of the system. Jitter is typically measured at the differential voltage zero-crossing during the logic state transition of a signal. Note that jitter present at the receiver threshold voltage level is considered by some to be a more effective representation of the jitter at the input of a receiver.

As the sum of skew and noise increases, the eye closes and data is corrupted. Closing the width decreases the time available for accurate sampling, and lowering the height enters the 900 mV or 500 mV threshold of a receiver.

Different sources induce noise onto a signal. The more obvious noise sources are the components of a transmission circuit themselves; the signal transmitter, traces & cables, connectors, and the receiver. Beyond that, there is a termination dependency, cross-talk from clock traces and other proximity effects, VCC & ground bounce, and electromagnetic interference from near-by electrical equipment.

The balanced receiver inputs of the HVD251 mitigate most all sources of signal corruption, and when used with a quality shielded twisted-pair cable, help insure data integrity.

Typical Application

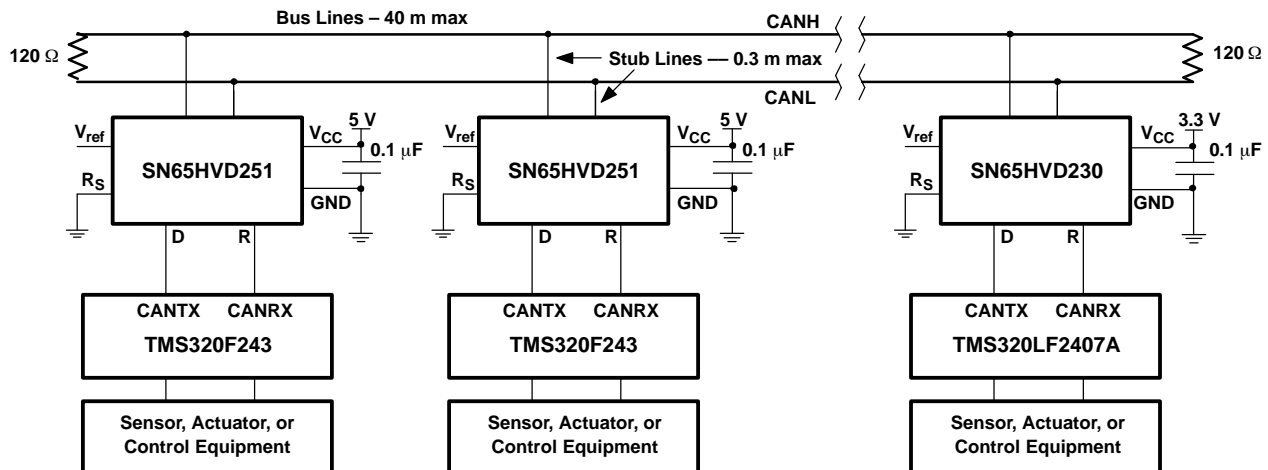

Figure 25. Typical HVD251 Application

P (R-PDIP-T8)

PLASTIC DUAL-IN-LINE



- NOTES: A. All linear dimensions are in inches (millimeters).
 B. This drawing is subject to change without notice.
 C. Falls within JEDEC MS-001

For the latest package information, go to http://www.ti.com/sc/docs/package/pkg_info.htm

D (R-PDSO-G**)

PLASTIC SMALL-OUTLINE PACKAGE

8 PINS SHOWN

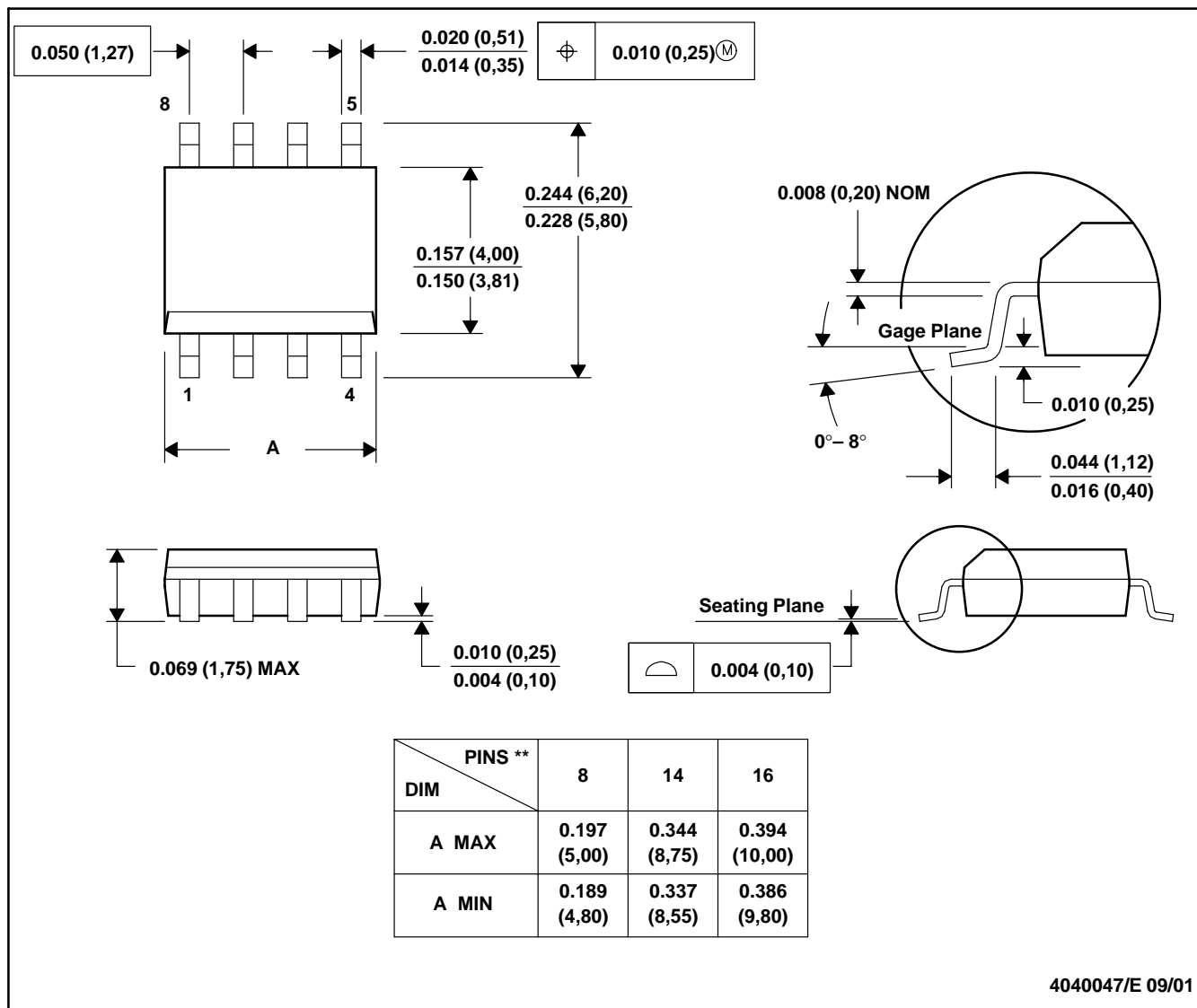

- NOTES: A. All linear dimensions are in inches (millimeters).
 B. This drawing is subject to change without notice.
 C. Body dimensions do not include mold flash or protrusion, not to exceed 0.006 (0,15).
 D. Falls within JEDEC MS-012

IMPORTANT NOTICE

Texas Instruments Incorporated and its subsidiaries (TI) reserve the right to make corrections, modifications, enhancements, improvements, and other changes to its products and services at any time and to discontinue any product or service without notice. Customers should obtain the latest relevant information before placing orders and should verify that such information is current and complete. All products are sold subject to TI's terms and conditions of sale supplied at the time of order acknowledgment.

TI warrants performance of its hardware products to the specifications applicable at the time of sale in accordance with TI's standard warranty. Testing and other quality control techniques are used to the extent TI deems necessary to support this warranty. Except where mandated by government requirements, testing of all parameters of each product is not necessarily performed.

TI assumes no liability for applications assistance or customer product design. Customers are responsible for their products and applications using TI components. To minimize the risks associated with customer products and applications, customers should provide adequate design and operating safeguards.

TI does not warrant or represent that any license, either express or implied, is granted under any TI patent right, copyright, mask work right, or other TI intellectual property right relating to any combination, machine, or process in which TI products or services are used. Information published by TI regarding third-party products or services does not constitute a license from TI to use such products or services or a warranty or endorsement thereof. Use of such information may require a license from a third party under the patents or other intellectual property of the third party, or a license from TI under the patents or other intellectual property of TI.

Reproduction of information in TI data books or data sheets is permissible only if reproduction is without alteration and is accompanied by all associated warranties, conditions, limitations, and notices. Reproduction of this information with alteration is an unfair and deceptive business practice. TI is not responsible or liable for such altered documentation.

Resale of TI products or services with statements different from or beyond the parameters stated by TI for that product or service voids all express and any implied warranties for the associated TI product or service and is an unfair and deceptive business practice. TI is not responsible or liable for any such statements.

Following are URLs where you can obtain information on other Texas Instruments products and application solutions:

Products		Applications	
Amplifiers	amplifier.ti.com	Audio	www.ti.com/audio
Data Converters	dataconverter.ti.com	Automotive	www.ti.com/automotive
DSP	dsp.ti.com	Broadband	www.ti.com/broadband
Interface	interface.ti.com	Digital Control	www.ti.com/digitalcontrol
Logic	logic.ti.com	Military	www.ti.com/military
Power Mgmt	power.ti.com	Optical Networking	www.ti.com/opticalnetwork
Microcontrollers	microcontroller.ti.com	Security	www.ti.com/security
		Telephony	www.ti.com/telephony
		Video & Imaging	www.ti.com/video
		Wireless	www.ti.com/wireless

Mailing Address: Texas Instruments
Post Office Box 655303 Dallas, Texas 75265

Copyright © 2004, Texas Instruments Incorporated