

Stellaris® LM4F232 Evaluation Board

User's Manual



Copyright

Copyright © 2011 Texas Instruments, Inc. All rights reserved. Stellaris and StellarisWare are registered trademarks of Texas Instruments. ARM and Thumb are registered trademarks, and Cortex is a trademark of ARM Limited. Other names and brands may be claimed as the property of others.

Texas Instruments
108 Wild Basin, Suite 350
Austin, TX 78746
<http://www.ti.com/stellaris>



Table of Contents

Chapter 1: Board Overview	6
Kit Contents	6
Using the EK-LM4F232	7
Features.....	7
Specifications.....	8
Chapter 2: Hardware Description	9
Functional Description	10
Microcontroller, USB OTG, User/Navigation Switches, User LED, and GPIO Headers (Schematic page 1)	10
Data Logger, Accelerometer, Temperature Sensor, OLED, and SD Card (Schematic page 2)	11
Hibernate, Current Shunts, Power Supplies, Reset, and Crystals (Schematic page 3).....	16
Debug and Virtual COM Port (Schematic Page 4).....	18
Chipcon Wireless Evaluation Module Connector (Schematic Page 5)	19
Chapter 3: Software Development	20
Software Description.....	20
Source Code	20
Tool Options	20
Programming the EK-LM4F232 Board	21
Appendix A: Schematics	22
Appendix B: Component Locations	28
Appendix C: Bill of Materials (BOM)	29
Appendix D: References	33

List of Figures

Figure 1-1. Stellaris® LM4F232 Evaluation Board 6

Figure 2-1. EK-LM4F232 Evaluation Board Block Diagram 9

Figure B-1. EK-LM4F232 Component Locations (Top View)..... 28

Figure B-2. EK-LM4F232 Component Locations (Bottom View)..... 28

List of Tables

Table 1-1. EK-LM4F232 Specifications	8
Table 2-1. USB Host/Device/OTG Signals	10
Table 2-2. User Switches and User LED Signals	11
Table 2-3. 4-Channel Analog Measurement Signals	12
Table 2-4. 3-Axis Analog Accelerometer Signals	13
Table 2-5. Temperature Sensor GPIO	13
Table 2-6. Linear Transfer Functions for Common Temperature Ranges.....	14
Table 2-7. Microcontroller Running Current Signals.....	15
Table 2-8. OLED Display Signals	15
Table 2-9. SD Card Signals.....	15
Table 2-10. Power Requirements.....	18
Table 2-11. Breakout Requirements.....	18
Table 2-12. Stellaris® In-Circuit Debug Interface (ICDI) Signals.....	19
Table 2-13. Virtual COM Port Signals	19
Table C-1. EK-LM4F232 Bill of Materials (BOM)	29

CHAPTER 1

Board Overview

The Stellaris® LM4F232 Evaluation Board (EK-LM4F232) is an evaluation platform for the Stellaris LM4F232H5QD ARM® Cortex™-M4F-based microcontroller. The evaluation board's design highlights the LM4F232H5QD microcontroller's USB 2.0 On-The-Go/Host/Device (USB OTG/Host/Device) interface, 12-bit Analog-to-Digital Converter (ADC), Real-Time Clock (RTC), and battery-backed Hibernation module. Figure 1-1 shows a photo of the EK-LM4F232.

Figure 1-1. Stellaris® LM4F232 Evaluation Board

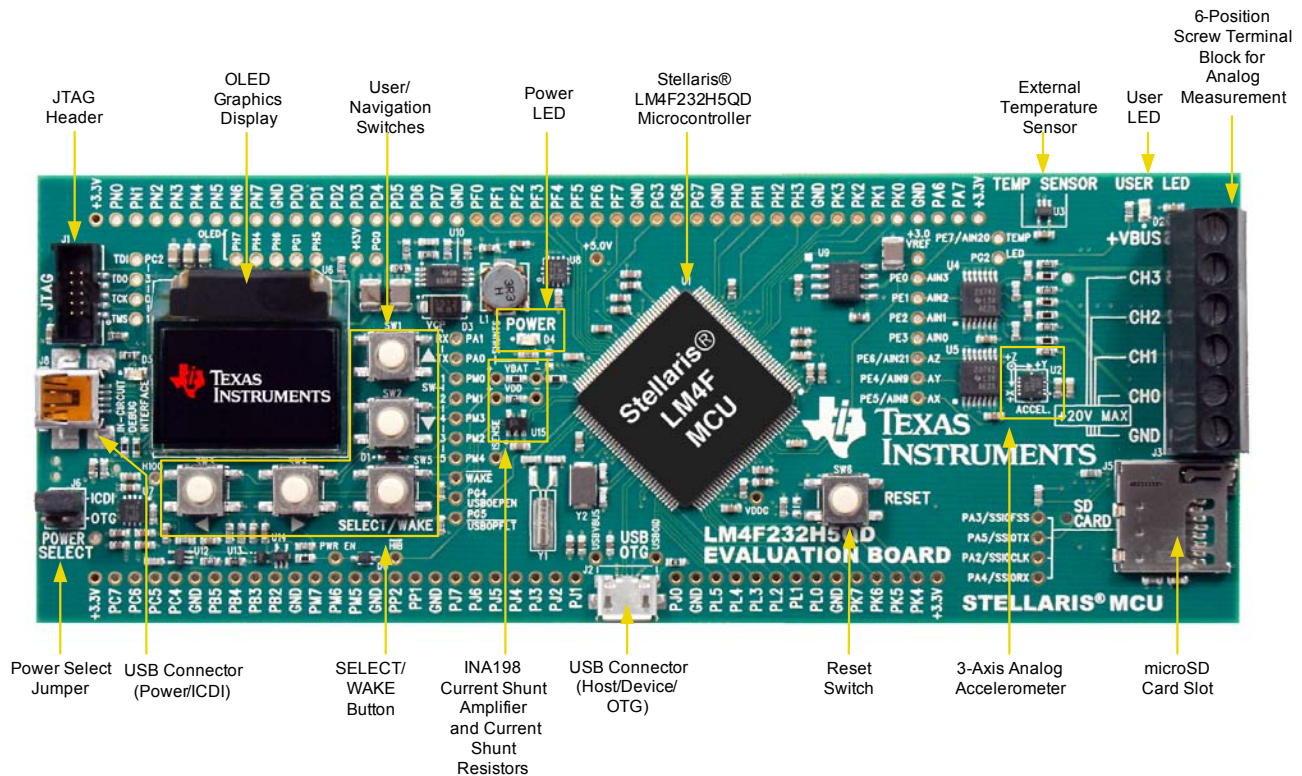

Kit Contents

The EK-LM4F232 evaluation kit comes with the following:

- Stellaris EK-LM4F232 evaluation board
- On-board Stellaris® In-Circuit Debug Interface (ICDI)
- Cables
 - USB Mini-B to USB-A plug cable (for debug)
 - USB Micro-A plug to USB-A receptacle cable
 - USB Micro-B plug to USB-A plug cable
- USB Flash drive

- 3 V CR2032 lithium coin cell battery
- CD containing:
 - StellarisWare® Peripheral Driver Library and example source code
 - Stellaris® Firmware Development Package with example source code
 - Quickstart application with source code
 - Windows companion application for quickstart application
 - Complete documentation
 - A supported version of one of the following:
 - Keil™ RealView® Microcontroller Development Kit (MDK-ARM)
 - IAR Embedded Workbench® development tools
 - Sourcery CodeBench development tools
 - Code Red Technologies development tools
 - Texas Instruments' Code Composer Studio™ IDE

Using the EK-LM4F232

The recommended steps for using the EK-LM4F232 evaluation kit are:

1. **Follow the README First document included in the kit.** The README First document will help get the EK-LM4F232 evaluation board up and running in minutes.
2. **Use your preferred ARM tool-chain and the Stellaris Peripheral Driver Library to develop an application.** Software applications are loaded using the on-board Stellaris® In-Circuit Debug Interface (ICDI). See Chapter 3, “Software Development” on page 20, for the programming procedure. The *StellarisWare Peripheral Driver Library Software Reference Manual* contains specific information on software structure and function.
3. **Customize and integrate the hardware to suit an end application.** This user's manual is an important reference for understanding circuit operation and completing hardware modification.

Features

The EK-LM4F232 evaluation kit includes the following features:

- Stellaris® LM4F232H5QD microcontroller
- Data logger demo application
 - 6 screw terminals
 - 4 analog inputs (0-20 V)
 - Power
 - Ground
 - 3-axis analog accelerometer
 - 2 Analog temperature sensors
 - External TMP20 temperature sensor
 - Internal microcontroller temperature sensor
 - Microcontroller current shunt amplifier

- 96 x 64 color OLED display
- USB Micro-AB connector for Host/Device/OTG
- microSD card slot
- 5 user/navigation switches
- User LED
- Precision 3.0 V reference
- Available I/O brought out to headers on 0.1" grid
- Debug
 - Stellaris® In-Circuit Debug Interface (ICDI)
 - Standard 10-pin JTAG header
- Shunt resistors to measure current on V_{BAT} and V_{DD}
- Coin cell backup battery for Hibernate mode
- Reset button

Specifications

Table 1-1 shows the specifications for the EK-LM4F232 evaluation board.

Table 1-1. EK-LM4F232 Specifications

Parameter	Value
Board supply voltage	4.75–5.25 V
Dimensions	6.0" x 2.25" x 0.84" (LxWxH)
RoHS status	Compliant

CHAPTER 2

Hardware Description

The EK-LM4F232 evaluation board includes a Stellaris LM4F232H5QD microcontroller and an integrated Stellaris® In-Circuit Debug Interface (ICDI) as well as a range of useful peripheral features (see the block diagram in Figure 2-1). This chapter describes how these peripherals operate and interface to the microcontroller.

Figure 2-1. EK-LM4F232 Evaluation Board Block Diagram

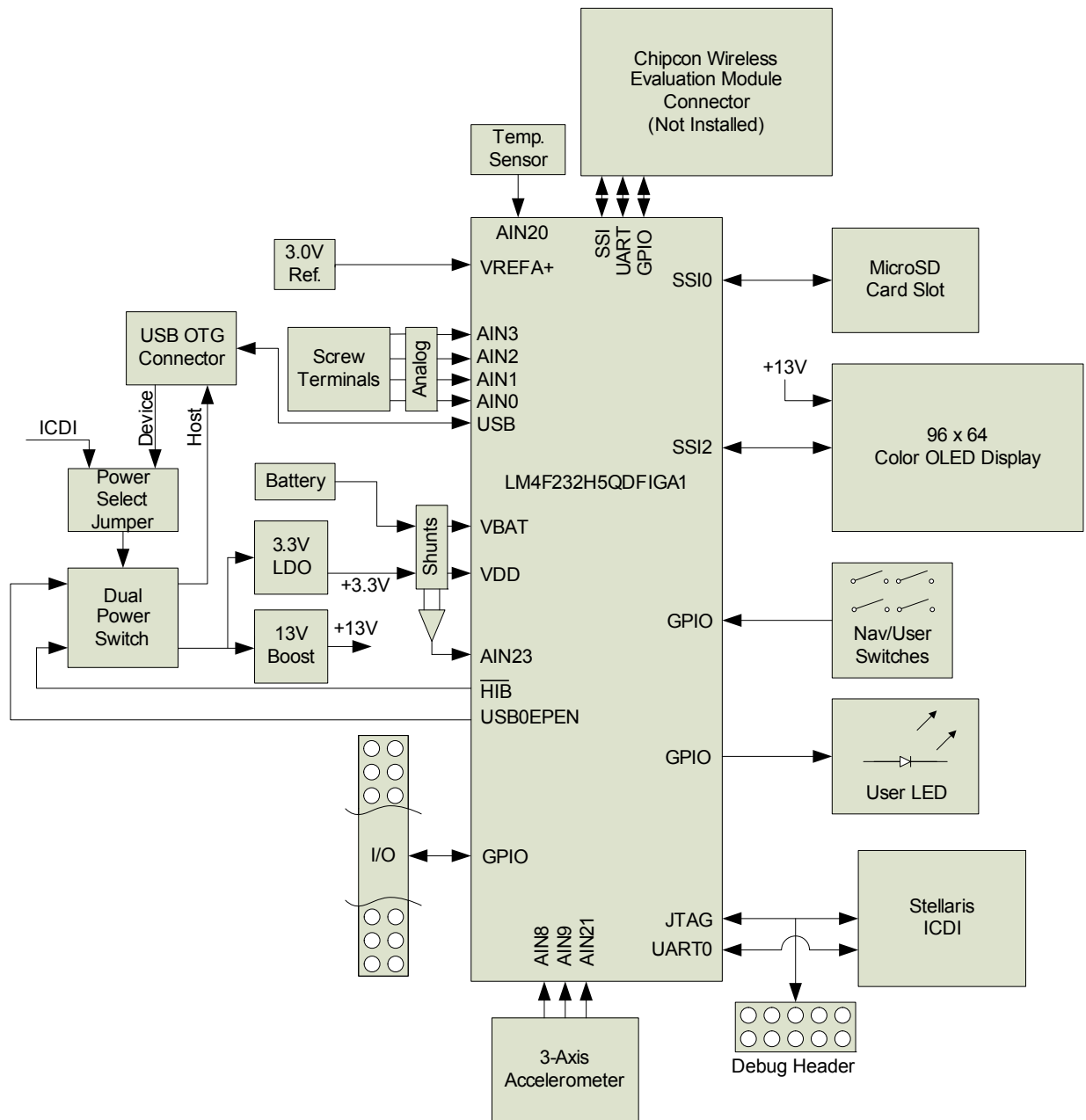

Functional Description

Microcontroller, USB OTG, User/Navigation Switches, User LED, and GPIO Headers (Schematic page 1)

Microcontroller

The Stellaris LM4F232H5QD is an ARM® Cortex™-M4F-based microcontroller with 256-KB Flash memory, 32-KB SRAM, 80-MHz operation, USB Host/Device/OTG, Hibernation module, and a wide range of other peripherals. See the LM4F232H5QD microcontroller data sheet (order number DS-LM4F232H5QD) for complete device details.

Most of the microcontroller signals are routed to 0.1" pitch break-out pads and labeled with their GPIO reference. An internal multiplexer allows different peripheral functions to be assigned to each of these GPIO pads. When adding external circuitry, consideration should be given to the additional load on the evaluation board's power rails.

The LM4F232H5QD microcontroller is factory-programmed with a quickstart demo program. The quickstart program resides in on-chip Flash memory and runs each time power is applied, unless the quickstart application has been replaced with a user program.

USB Host/Device/OTG

The EK-LM4F232 includes a USB Micro-AB (OTG) connector to allow for USB Host, Device, and OTG operation. The following signals are used for USB OTG.

Table 2-1. USB Host/Device/OTG Signals

GPIO Pin	Pin Function	USB OTG
PL6	USB0DP	D+
PL7	USB0DM	D-
PB0	USB0ID	ID
PB1	USB0VBUS	USB VBUS
GPIO Pin	Pin Function	Load Switch
PG4	USB0EPEN	USB VBUS Power Enable (EN2)
PG5	USB0PFLTn	Power Fault (OC2n)

In USB Host mode, the evaluation board can provide power to the OTG connector. The `USB0EPEN` signal controls the Channel 2 Enable (`EN2`) of a Texas Instruments' TPS2052B Load Switch (U7) which enables power to the connector's V_{BUS} pin. The POWER SELECT jumper must be in the "ICDI" position.

In Device mode, the evaluation board can be powered from either the Stellaris® ICDI or the OTG connectors. The user can select the power source by moving the POWER SELECT jumper to the appropriate position.

In OTG mode, the POWER SELECT jumper's position needs special consideration depending on the system and code configuration.

User Switches and User LED

Five switches on the board provide navigation and selection for the preloaded quickstart application. These switches can be used for other purposes in the user's custom applications.

The evaluation board also has a green user LED.

Table 2-2 shows how these features are connected to the pins on the microcontroller.

Table 2-2. User Switches and User LED Signals

GPIO Pin	Pin Function	Feature
PM0	GPIO	SW1 (Up)
PM1	GPIO	SW2 (Down)
PM2	GPIO	SW3 (Left)
PM3	GPIO	SW4 (Right)
PM4	GPIO	SW5 (Select/Wake)
PG2	GPIO	User LED

GPIO Headers

All unused pins on the microcontroller as routed out to 0.1" headers along the edges of the board and are conveniently labeled with their port and pin names.

The remaining pins are broken out to headers located near the hardware feature that uses them. These are also on a 0.1" grid. All of these headers are labeled with the port and pin name, and, where possible, labeled with their function. See "Schematics" on page 22 for detailed information on these signals.

Data Logger, Accelerometer, Temperature Sensor, OLED, and SD Card (Schematic page 2)

Data Logger

The EK-LM4F232 comes with a quickstart application loaded into the Flash memory. This application implements a multi-channel data logger which can measure up to four analog channels (0-20 V), a three-axis analog accelerometer, two analog temperature sensors, and the microcontroller running current.

A Windows quickstart companion application is also provided on the evaluation kit CD and serves as a secondary display for the Data Logger application. See the "Software Description" on page 20 for more information.

4-Channel Analog Measurement

A 6-position screw terminal block is included on the evaluation board to make easy connections to external signals. Table 2-3 shows how the screw terminals and channels are arranged.

Table 2-3. 4-Channel Analog Measurement Signals

GPIO Pin	Pin Function	Terminal
-	-	+VBUS
PE0	AIN3	CH3
PE1	AIN2	CH2
PE2	AIN1	CH1
PE3	AIN0	CH0
-	-	GND

Each of the 4 channels can measure 0-20 V with an approximate 0.01 V resolution. A voltage divider on each channel scales the 0-20 V range on the terminal to the 0-3 V range of the 12-bit Analog-to-Digital Converter (ADC) of the LM4F232H5QD microcontroller. Each scaled-down signal passes through a unity-gain amplifier to provide a low-impedance source for the microcontroller's ADC. Below are some useful equations to keep on hand when using the four data logger channels.

$$V_{TERMINAL} = \frac{V_{ADC}}{\left(\frac{R_2}{R_1 + R_2}\right)} = \frac{V_{ADC}}{\left(\frac{18000}{105000 + 18000}\right)} \approx \frac{V_{ADC}}{0.146}$$

$$V_{ADC} = \frac{V_{REFA+}}{2^{12} - 1} \times ADCCODE = \frac{3.0V}{4095} \times ADCCODE \approx 0.7326mV \times ADCCODE$$

For example, if the code read from the ADC is 2048, the voltage measured by the ADC is:

$$V_{ADC} = 0.7326mV \times 2048 = 1.5V$$

Therefore, the voltage being measured at the screw terminal is:

$$V_{TERMINAL} = \frac{V_{ADC}}{0.146} = \frac{1.5V}{0.146} = 10.27V$$

Caution – Exceeding the input range on either the screw terminal or the ADC pins directly can damage the analog circuitry.

3-Axis Analog Accelerometer

The evaluation board includes a Bosch BMA140 3-axis analog accelerometer. The accelerometer is powered by a Texas Instruments' REF5030 Precision 3.0 V Reference (U9) and outputs an analog signal centered on half the 3.0 V source; therefore, 0 g translates to 1.5 V on the output. The sensor can measure accelerations up to ± 4 g.

Each axis has its own analog signal; A_X , A_Y , and A_Z . The sensor outputs are passed through a unity-gain amplifier to provide a low-impedance source for the microcontroller's ADC. Table 2-4 shows which microcontroller pins are used for the accelerometer,

Table 2-4. 3-Axis Analog Accelerometer Signals

GPIO Pin	Pin Function	Accelerometer
PE5	AIN8	A_X
PE4	AIN9	A_Y
PE6	AIN21	A_Z

The following equations from the *Bosch Sensortec Triaxial, Analog Acceleration Sensor Data Sheet (BMA140)* define the sensor output (A_X , A_Y , and A_Z) in volts based on the acceleration vector in each direction (a_X , a_Y , and a_Z) in g's and the sensor sensitivity (S) in V/g. All three axes share the same relation, therefore, only the equation for the X axis is shown.

$$S = \frac{V_{DD}}{10} = 0.3V$$

$$A_X = \left(\frac{V_{DD}}{2} + S \times a_X \right) = 1.5V + 0.3V \times a_X$$

Given the code read from the ADC, the acceleration vector can be calculated as follows:

$$A_X = V_{ADC} = \frac{V_{REFA+}}{2^{12} - 1} \times ADCCODE = \frac{3.0V}{4095} \times ADCCODE \approx 0.7326mV \times ADCCODE$$

$$a_x = \frac{A_X - 1.5V}{0.3V} = \frac{(0.7326mV \times ADCCODE) - 1.5V}{0.3V} = (0.002442 \times ADCCODE) - 5$$

For example, if the code read from the ADC on A_X is 2457, the acceleration measured is:

$$a_x = (0.002442 \times ADCCODE) - 5 = (0.002442 \times 2457) - 5 = 1g$$

See the *Bosch Sensortec Triaxial, Analog Acceleration Sensor Data Sheet (BMA140)* for more information about the accelerometer.

Temperature Sensors

Temperature can be measured by the Texas Instruments' TMP20 Analog Temperature Sensor (U3) and/or the internal microcontroller temperature sensor.

External TMP20 Temperature Sensor

The output of the sensor is passed through a unity-gain amplifier to provide a low-impedance source for the microcontroller's ADC. Table 2-5 shows the signal used by the temperature sensor.

Table 2-5. Temperature Sensor GPIO

GPIO Pin	Pin Function	Temp. Sensor
PE7	AIN20	V_{OUT}

The sensor's analog output over the -55°C to +130°C temperature range corresponds to the parabolic transfer function (taken from the TMP20 data sheet):

$$V_{OUT} = (-3.88 \times 10^{-6} \times T^2) + (-1.15 \times 10^{-2} \times T) + 1.8639V$$

Where the temperature T is in °C. Solving for temperature results in the following equation:

$$T = -1481.96 + \sqrt{\frac{2.19262 \times 10^6 + (1.8639 - V_{OUT})}{3.88 \times 10^{-6}}}$$

When only concerned with a narrow temperature range, a linear transfer function can be calculated. See the *±2.5°C Low-Power, Analog Out Temperature Sensor Data Sheet (TMP20)* for these calculations. Table 2-6 shows the linear transfer functions for a common selection of temperature ranges.

Table 2-6. Linear Transfer Functions for Common Temperature Ranges

Temperature Range		Linear Equation (V)	Maximum Deviation from Parabolic Equation (°C)
T _{MIN} (°C)	T _{MAX} (°C)		
-55	130	$V_{OUT} = -11.79\text{mV}/^\circ\text{C} \times T + 1.8528$	±1.41
-40	110	$V_{OUT} = -11.77\text{mV}/^\circ\text{C} \times T + 1.8577$	±0.93
-30	100	$V_{OUT} = -11.77\text{mV}/^\circ\text{C} \times T + 1.8605$	±0.70
-40	85	$V_{OUT} = -11.67\text{mV}/^\circ\text{C} \times T + 1.8583$	±0.65
-10	65	$V_{OUT} = -11.71\text{mV}/^\circ\text{C} \times T + 1.8641$	±0.23
35	45	$V_{OUT} = -11.81\text{mV}/^\circ\text{C} \times T + 1.8701$	±0.004
20	30	$V_{OUT} = -11.69\text{mV}/^\circ\text{C} \times T + 1.8663$	±0.004

Internal Microcontroller Temperature Sensor

The LM4F232H5QD microcontroller has an internal temperature sensor that can be used to notify the system that the internal temperature is too high or low for reliable operation. The temperature sensor can be sampled internally by the ADC. Given the ADC reading, the internal temperature, T in °C, can be calculated as follows (taken from the LM4F232H5QD data sheet):

$$T = 147.5 - \frac{225 \times ADCCODE}{4095}$$

See the LM4F232H5QD data sheet for more information on the internal microcontroller temperature sensor.

Microcontroller Running Current

The microcontroller running current I_{DD} can be measured by the microcontroller itself. The output of a Texas Instruments' INA198 Current Shunt Amplifier (U15) is connected to the ADC on the microcontroller. This amplifier increases the voltage drop on a 0.1-Ohm current shunt resistor in

line with the V_{DD} source for the microcontroller. Table 2-7 shows the signal used to measure the amplifier output.

Table 2-7. Microcontroller Running Current Signals

GPIO Pin	Pin Function	Amplifier
PP0	AIN23	OUT

See “Current Shunt Resistors” on page 17 for more details on calculating the running current from the ADC readings.

OLED Display

The evaluation board includes a 96 x 64 color Organic LED (OLED) display. The OLED display is powered from the on-board 13 V regulator which has to be enabled before using the display.

Data is written to the display using the SSI2 peripheral. Table 2-8 shows the signals used by the display.

Table 2-8. OLED Display Signals

GPIO Pin	Pin Function	OLED Function
PH7	SSI2TX	SDIN
PH5	SSI2FSS	CSn
PH4	SSI2CLK	SCLK
PH6	GPIO	D/Cn
PG1	GPIO	RSTn
PG0	GPIO	+13VEN

SD Card

The EK-LM4F232 features a microSD card slot. Table 2-9 shows the signals used with the SD card.

Table 2-9. SD Card Signals

GPIO Pin	Pin Function	SD Card Function
PA5	SSI0TX	DI
PA4	SSI0RX	DO
PA3	SSI0FSS	CSn
PA2	SSI0CLK	CLK

Hibernate, Current Shunts, Power Supplies, Reset, and Crystals (Schematic page 3)

Hibernate

The EK-LM4F232 provides a 32.768 kHz crystal (Y1) as the clock source for the LM4F232H5QD's Hibernation module clock source. It also provides a separate 3.0-V CR2032 lithium coin-cell backup battery connected to V_{BAT} that provides power to the Hibernation module when the microcontroller is in Hibernate mode. The current draw while in Hibernate mode can be measured indirectly by measuring the voltage across the 1-k Ω current shunt resistor. See the section, "Current Shunt Resistors" on page 17 for more details.

Several conditions can generate a wake signal to the Hibernate module; waking on a Real-time Clock (RTC) match, waking on low battery, and/or waking on assertion of the \overline{WAKE} pin.¹ The SELECT/WAKE switch is connected to the \overline{WAKE} pin on the microcontroller. When the microcontroller is configured to wake on \overline{WAKE} assertion, the switch can be used to wake the part from Hibernate mode. The SELECT/WAKE switch is also connected to PM4 by way of a diode to prevent PM4 from asserting \overline{WAKE} when the part enters Hibernate mode. See Appendix A, "Schematics" on page 22 for details.

To achieve the lowest power consumption while in Hibernate mode, the \overline{HIB} signal is connected to the Channel 1 Enable ($\overline{EN1}$) signal of the Texas Instruments' TPS2052B load switch (U7). In Hibernate mode, the \overline{HIB} signal is asserted and the load switch cuts main power to the entire board, including the on-board Stellaris ICDI.² The Hibernation module is powered solely by the back-up battery.

The EK-LM4F232 has additional circuitry that allows the evaluation board to be turned on even when a battery is not present or when the battery voltage is too low. A Texas Instruments' TPS3803-01 Voltage Detector (U12) monitors V_{BAT} and produces a V_{BAT_GOOD} signal when the battery voltage is above 2.1 V. Using standard logic gates and the state of V_{BAT} and V_{DD} , the \overline{HIB} signal can be forced high when V_{BAT} is not valid and the microcontroller is not already powered. With this circuit, a USB-powered board can turn itself on when the back-up battery is either missing or fully discharged. See Appendix A, "Schematics" on page 22 for more details.

This additional circuitry may not be needed in all applications. For example, a device powered by one main battery that doubles as the back-up battery does not need this circuit. Or, when using the Hibernate module in VDD3ON mode, power is cut to the microcontroller internally which eliminates the need to use \overline{HIB} to turn off an external supply.

There are many different ways that Hibernate mode can be implemented in an embedded system. Each implementation requires its own special design considerations.

-
1. If the board does not turn on when you connect it to a power source, the microcontroller might be in Hibernate mode (depending on the programmed application). You must satisfy one of the programmed wake conditions and connect the power to bring the microcontroller out of Hibernate mode and turn on the board.
 2. If you remove power to the on-board Stellaris ICDI, the Stellaris ICDI disconnects from the attached PC and your IDE. If you are debugging an application when the microcontroller enters Hibernate mode, the IDE might exhibit unwanted behaviors due to the sudden loss of the Stellaris ICDI. If you are using an externally powered debugger, the connection between the debugger and the PC should not be affected.

Regardless of the debugger setup, the JTAG module in the microcontroller is turned off when the device is in Hibernation mode, which means the debugger cannot communicate to the target microcontroller. See the LM4F232H5QD data sheet for more information about the microcontroller's state in Hibernate mode.

Current Shunt Resistors

The evaluation board provides two current shunt resistors to measure the microcontroller running current, I_{DD} , and the Hibernation mode battery current, I_{BAT} . I_{DD} can be measured by the microcontroller through a Texas Instruments' INA198 Current Shunt Amplifier (U15). See "Microcontroller Running Current I_{DD} " on page 17. I_{BAT} must be measured externally.

Microcontroller Running Current I_{DD}

The shunt resistor for I_{DD} , $R_{VDDSHUNT}$, is 0.1 Ohms and the INA198 amplifier gain is 100 V/V.

Therefore:

$$I_{DD} = \frac{V_{VDDSHUNT}}{R_{VDDSHUNT}} = \frac{V_{VDDSHUNT}}{0.1}$$

$$V_{ADC} = V_{VDDSHUNT} \times Gain = V_{VDDSHUNT} \times 100$$

Given the ADC measurement, you can calculate I_{DD} :

$$I_{DD} = \frac{V_{VDDSHUNT}}{R_{VDDSHUNT}} = \frac{\left(\frac{V_{ADC}}{100}\right)}{0.1} = \frac{V_{ADC}}{10}$$

Or simply, 10 mV per mA.

Hibernation Mode Battery Current I_{BAT}

The shunt resistor for I_{BAT} , $R_{VBATSHUNT}$, is 1 kOhm.

$$I_{BAT} = \frac{V_{VBATSHUNT}}{R_{VBATSHUNT}} = \frac{V_{VBATSHUNT}}{1000}$$

Or simply, 1 mV per μ A.

Clocking

The EK-LM4F232 uses a 16.0-MHz crystal (Y2) to complete the LM4F232H5QD microcontroller's main internal clock circuit. An internal PLL, configured in software, multiplies this clock to higher frequencies for core and peripheral timing.

The Hibernation module is clocked from an external 32.768 kHz crystal (Y1).

Reset

The $\overline{\text{RESET}}$ signal into the LM4F232H5QD microcontroller connects to the RESET switch and to the Stellaris® ICDI circuit for a debugger-controlled reset.

External reset is asserted (active low) under any one of these conditions:

- Power-on reset
- RESET switch held down
- By the Stellaris® ICDI circuit when instructed by the debugger (this capability is optional, and may not be supported by all debuggers)

The OLED display has special reset timing requirements requiring a dedicated control line from the microcontroller.

Power Supplies and Jumper

The EK-LM4F232 can be powered from one of two power sources:

- Stellaris® ICDI USB cable (default)
- USB OTG cable

A moveable jumper shunt on the POWER SELECT headers is used to select one of the two power sources. Only one source should be selected at a time.

See “USB Host/Device/OTG” on page 10 for the recommended jumper positions for the specific USB modes.

The evaluation board is designed to provide power to a limited amount of external circuitry. Table 2-10 shows the board's power requirements and Table 2-11 shows the board's breakout requirements.

Table 2-10. Power Requirements

Board Supply	Min	Typical	Max	Unit
ICDI USB Cable	4.75	5.0	5.25	V
USB OTG Cable				

Table 2-11. Breakout Requirements

Breakout	Condition	Max	Unit
+3.3 V	—	260	mA
+5.0 V ^{a,b}	+3.3 V @ 260 mA, OLED on	350	mA
	+3.3 V @ 260 mA, OLED off	380	mA

- a. This represents the +5.0 V breakout and the +V_{BUS} breakout. Total current = I_{5V} + I_{V_{BUS}}.
- b. +5.0 V is switched by the load switch (U7); however, +V_{BUS} is always connected.

Debug and Virtual COM Port (Schematic Page 4)

Stellaris® In-Circuit Debug Interface (ICDI) and Virtual COM Port

The EK-LM4F232 evaluation board comes with an on-board Stellaris® In-Circuit Debug Interface (ICDI). The Stellaris® ICDI allows for the programming and debug of the LM4F232H5QD using LM Flash Programmer and/or any of the supported tool chains. Both JTAG and Serial Wire Debug (SWD) are supported.

NOTE: Although other Stellaris kits support debug out, the EK-LM4F232 evaluation board does not support this. You can use another Stellaris evaluation kit for debug out.

An external debugger can be connected to the evaluation board through a 2 x 5 fine pitch (0.05”) ARM JTAG header. When connecting an external debugger, pin 3 of the JTAG header must be tied

to ground in order for the Stellaris® ICDI to release control of the JTAG signals. The ARM standard pinout specifies pin 3 as ground, therefore, any standard third-party debugger should work.

Table 2-12 shows the pins used for JTAG and SWD.

Table 2-12. Stellaris® In-Circuit Debug Interface (ICDI) Signals

GPIO Pin	Pin Function	JTAG Header Pin
PC0	TCK/SWCLK	4
PC1	TMS/SWDIO	2
PC2	TDI	8
PC3	TDO/SWO	6
RST	$\overline{\text{RST}}$	10
GPIO Pin	Pin Function	ICDI Function
—	$\overline{\text{EXTDBG}}$	3

See Appendix A, “Schematics” on page 22 for the full header pinout.

Virtual COM Port

When plugged in to a PC, the device enumerates as a debugger and a virtual COM port.

Table 2-13 shows the connections for the COM port to the pins on the microcontroller.

Table 2-13. Virtual COM Port Signals

GPIO Pin	Pin Function	Virtual COM Port
PA0	U0RX	TXD
PA1	U0TX	RXD

Chipcon Wireless Evaluation Module Connector (Schematic Page 5)

These features are not populated on the board. The pads have been laid out on the board for customers who want to solder the headers to connect a Texas Instruments’ wireless evaluation module. See Appendix C, “Bill of Materials (BOM)” on page 29 for the orderable part numbers that can be populated on the pads (J9, J10, Y4, C66, and C67).

Although no wireless software support is provided out of the box, customers and third parties are encouraged to port existing wireless projects to the EK-LM4F232 evaluation board through the use of this interface. See the Chipcon Wireless Evaluation Module Connector schematic on page 27 for information on what peripherals are connected to the wireless headers.

CHAPTER 3

Software Development

This chapter provides general information on software development as well as instructions for Flash memory programming.

Software Description

The software provided with the EK-LM4F232 provides access to all of the peripheral devices supplied in the design. The StellarisWare® Peripheral Driver Library is used to operate the on-chip peripherals.

The software includes a set of example applications that use the StellarisWare® Peripheral Driver Library. These applications demonstrate the capabilities of the LM4F232H5QD microcontroller, as well as provide a starting point for the development of the final application for use on the EK-LM4F232 evaluation board.

The EK-LM4F232 Evaluation Kit CD also contains a Windows quickstart companion for the Data Logger quickstart application. The companion application provides a strip-chart display for up to 10 channels of data from the EK-LM4F232 evaluation board. You can enable or disable the display for each channel and log the data to a comma-separated values (CSV) file.

Source Code

The complete source code is included on the EK-LM4F232 CD including the source code for the Windows quickstart companion application. See the README First document for a detailed description of hardware setup and how to install the source code. The source code and binary files are installed in the StellarisWare® software tree.

Tool Options

The source code installation includes directories containing projects and/or makefiles for the following tool-chains:

- Keil ARM RealView® Microcontroller Development System
- IAR Embedded Workbench for ARM
- Sourcery CodeBench
- Code Red Technology Red Suite
- Generic Gnu C compiler
- Texas Instruments' Code Composer Studio™ IDE

Download evaluation versions of these tools from www.ti.com/stellaris. Due to code size restrictions, the evaluation tools may not build all example programs. A full license is necessary to re-build or debug all examples.

Instructions on installing and using each of the evaluation tools can be found in the Quickstart guides (for example, Quickstart-Keil, Quickstart-IAR) which are available for download from the evaluation kit section of our web site at www.ti.com/stellaris.

For detailed information on using the tools, see the documentation included in the tool chain installation or visit the web site of the tools supplier.

Programming the EK-LM4F232 Board

The EK-LM4F232 software package includes pre-built binaries for each of the example applications. If you installed the StellarisWare® software to the default installation path of C:/StellarisWare, you can find the example applications in “C:/StellarisWare/boards/ek-lm4f232”. The on-board Stellaris ICDI is used with the Stellaris LM Flash Programmer tool to program applications on the EK-LM4F232 board.

Follow these steps to program example applications into the EK-LM4F232 evaluation board using the Stellaris® ICDI:

1. Install LM Flash Programmer on a Windows PC.
2. Connect the USB-A cable plug to an available port on the PC and the Mini-B plug to the board.
3. Verify that the POWER LED D4 on the board is lit.
4. Run LM Flash Programmer.
5. In the Configuration tab, use the Quick Set control to select the EK-LM4F232 evaluation board.
6. Move to the Program tab and click the Browse button. Navigate to the example applications directory (the default location is “C:/StellarisWare/boards/ek-lm4f232”).
7. Each example application has its own directory. Navigate to the example directory that you want to load and then into the directory which contains the binary (*.bin) files. Select the binary file and click Open.
8. Set the “Erase Method” to “Erase Necessary Pages,” check the “Verify After Program” box, and check “Reset MCU After Program”.
9. Click the Program button to start the Erase, Download, and Verify process. The DEBUG ACTIVE LED (D5) on the board turns on at this time.

Program execution starts once the Verify process is complete.

Schematics

This section contains the schematics for the EK-LM4F232 board.

- Microcontroller, USB OTG, User Switches, and LED on page 23
- Logger, Temp Sensor, OLED, SD Card on page 24
- Power on page 25
- Stellaris In-Circuit Debug Interface (ICDI) on page 26
- Chipcon Wireless Evaluation Module Connector on page 27

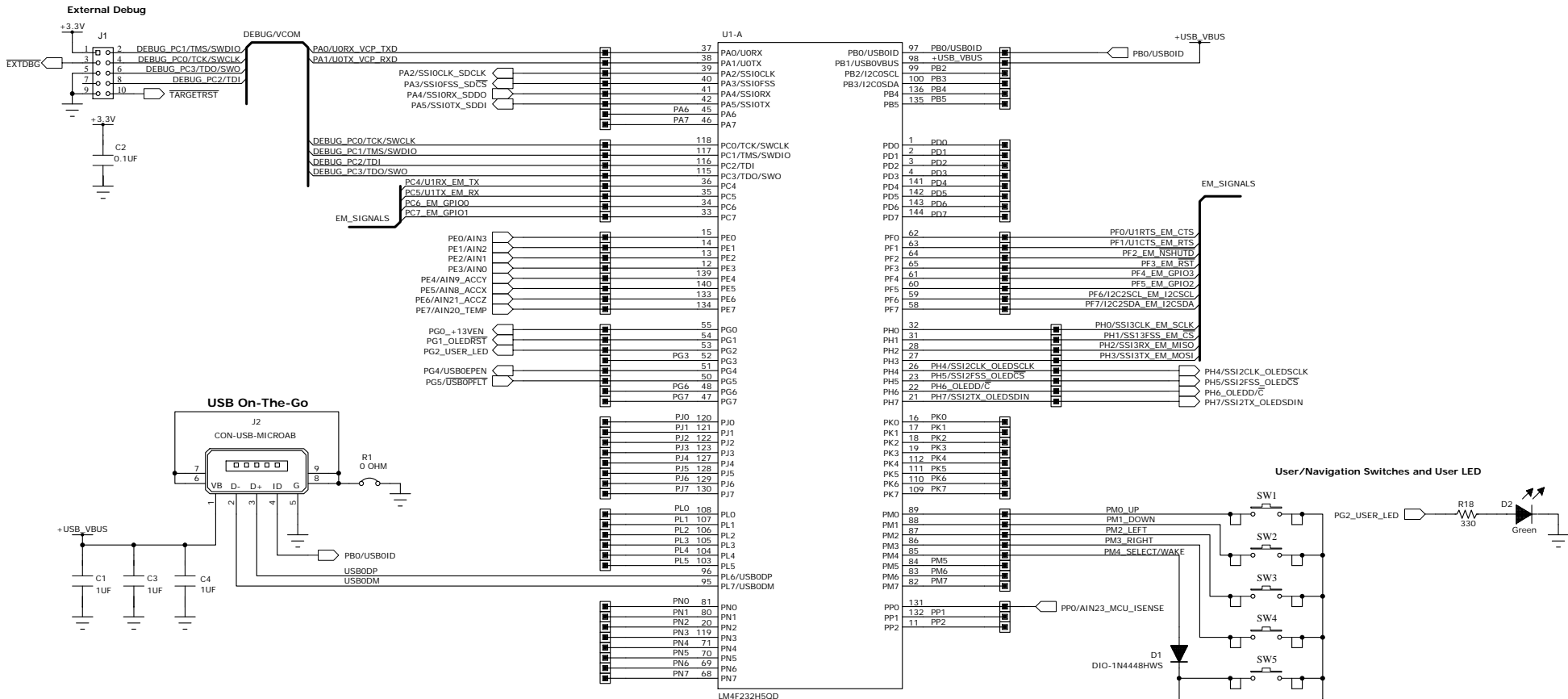

DESIGNER	REVISION	DATE
DAY	A	10/26/2012
PROJECT		
LM4F232H50D Evaluation Kit		
DESCRIPTION		
Microcontroller, USB OTG, User Switches and LED		
FILENAME	Armadillo Rev A.sch	

 <p>TEXAS INSTRUMENTS STELLARIS[®] MICROCONTROLLERS</p> <p>108 WILD BASIN ROAD, SUITE 350 AUSTIN TX, 78746 www.ti.com/stellaris</p>	PART NO.	EK-LM4F232
	SHEET	1 OF 5

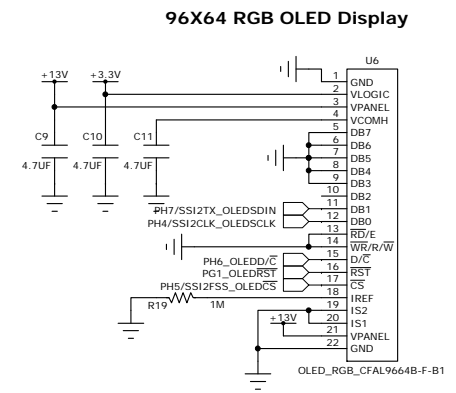
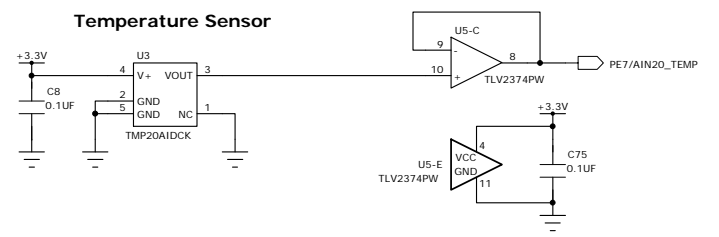
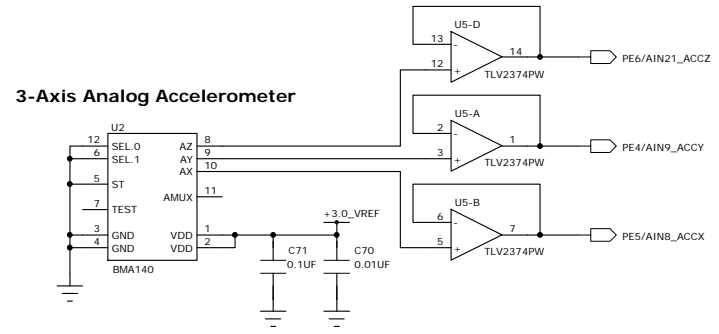
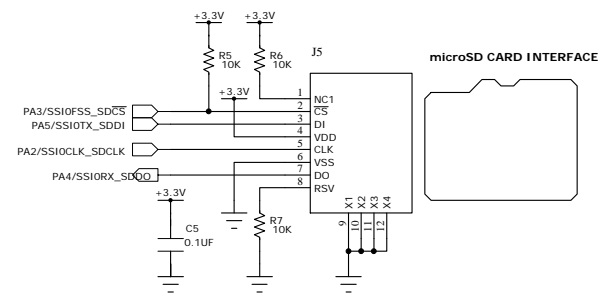
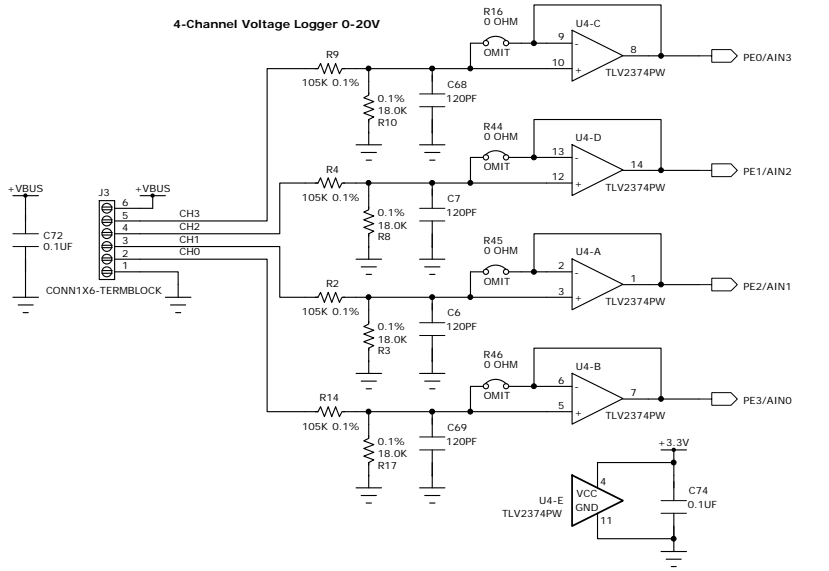

DESIGNER	REVISION	DATE
DAY	A	10/26/2012
PROJECT		
LM4F232H5QD Evaluation Kit		
DESCRIPTION		
Logger, Temp Sensor, OLED, SD Card		
FILENAME	Armadillo Rev A.sch	

	TEXAS INSTRUMENTS STELLARIS [®] MICROCONTROLLERS 108 WILD BASIN ROAD, SUITE 350 AUSTIN TX, 78746 www.ti.com/stellaris	
	PART NO.	SHEET
EK-LM4F232	2 OF 5	

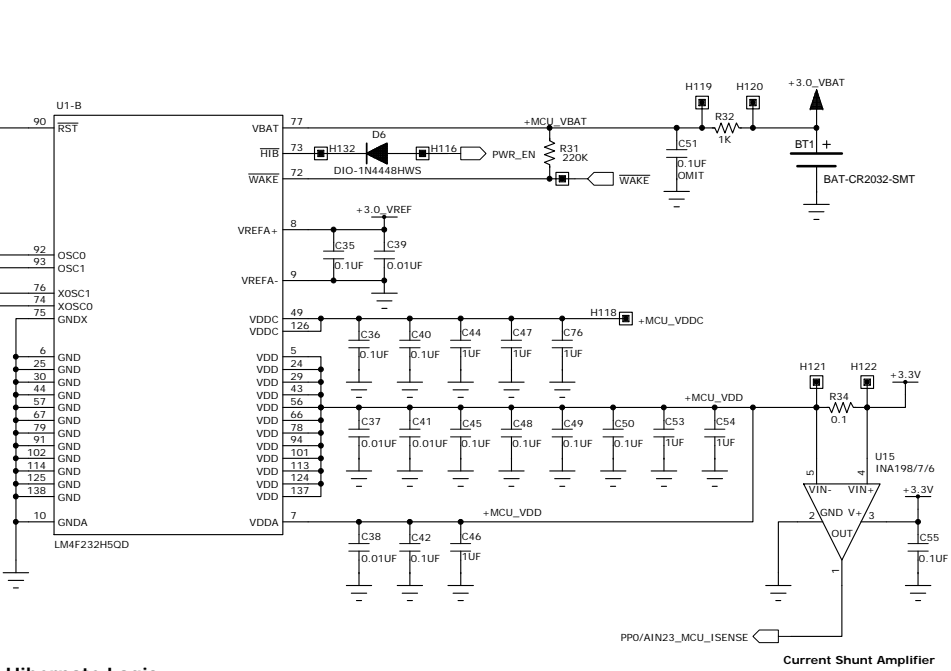
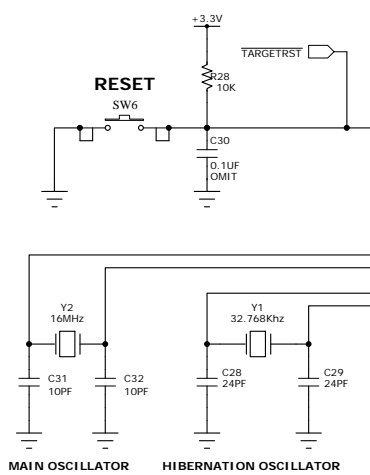
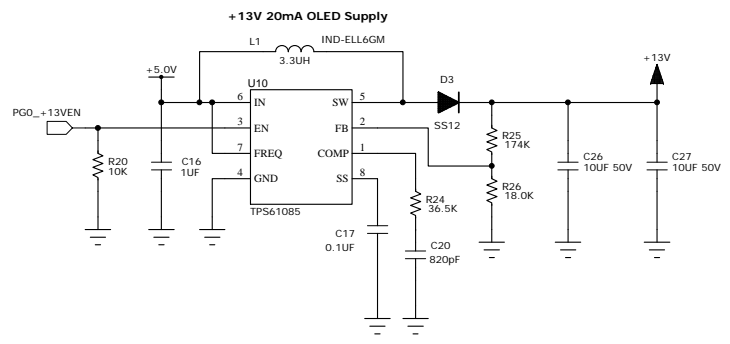
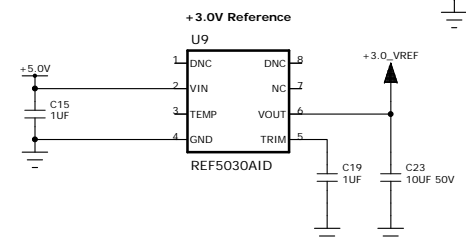
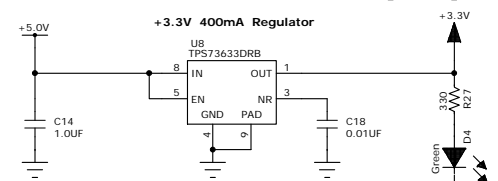
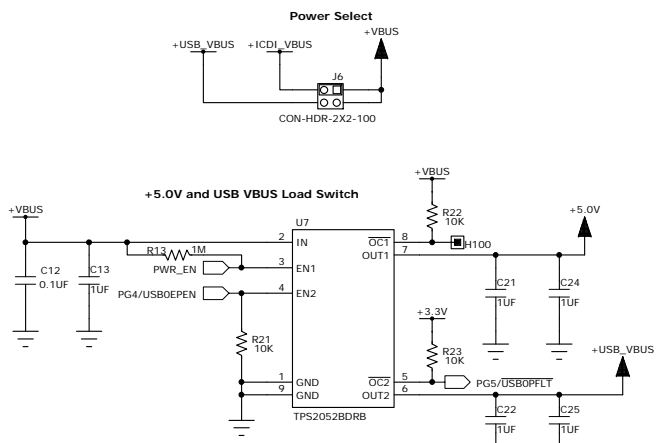

Hibernate Logic
 Not required for VDD3ON mode or when using a single power source. (see datasheet)

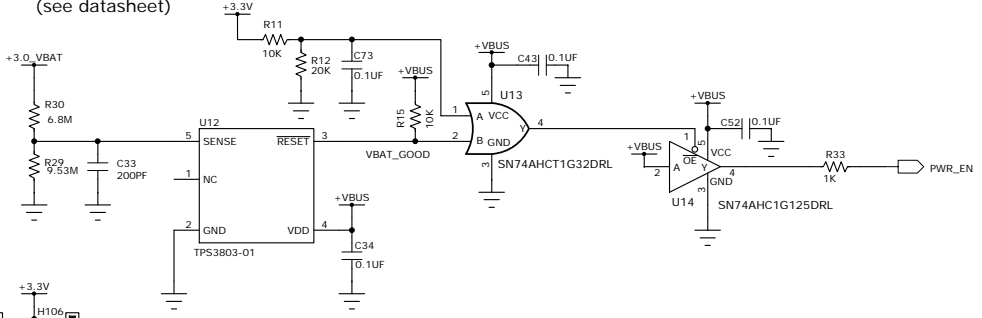

DESIGNER	REVISION	DATE
DAY	A	10/26/2012
PROJECT		
LM4F232H50D Evaluation Kit		
DESCRIPTION		
Power		
FILENAME	Armadillo Rev A.sch	

	TEXAS INSTRUMENTS STELLARIS® MICROCONTROLLERS 108 WILD BASIN ROAD, SUITE 350 AUSTIN TX, 78746 www.ti.com/stellaris	
	PART NO. EK-LM4F232	SHEET 3 OF 5

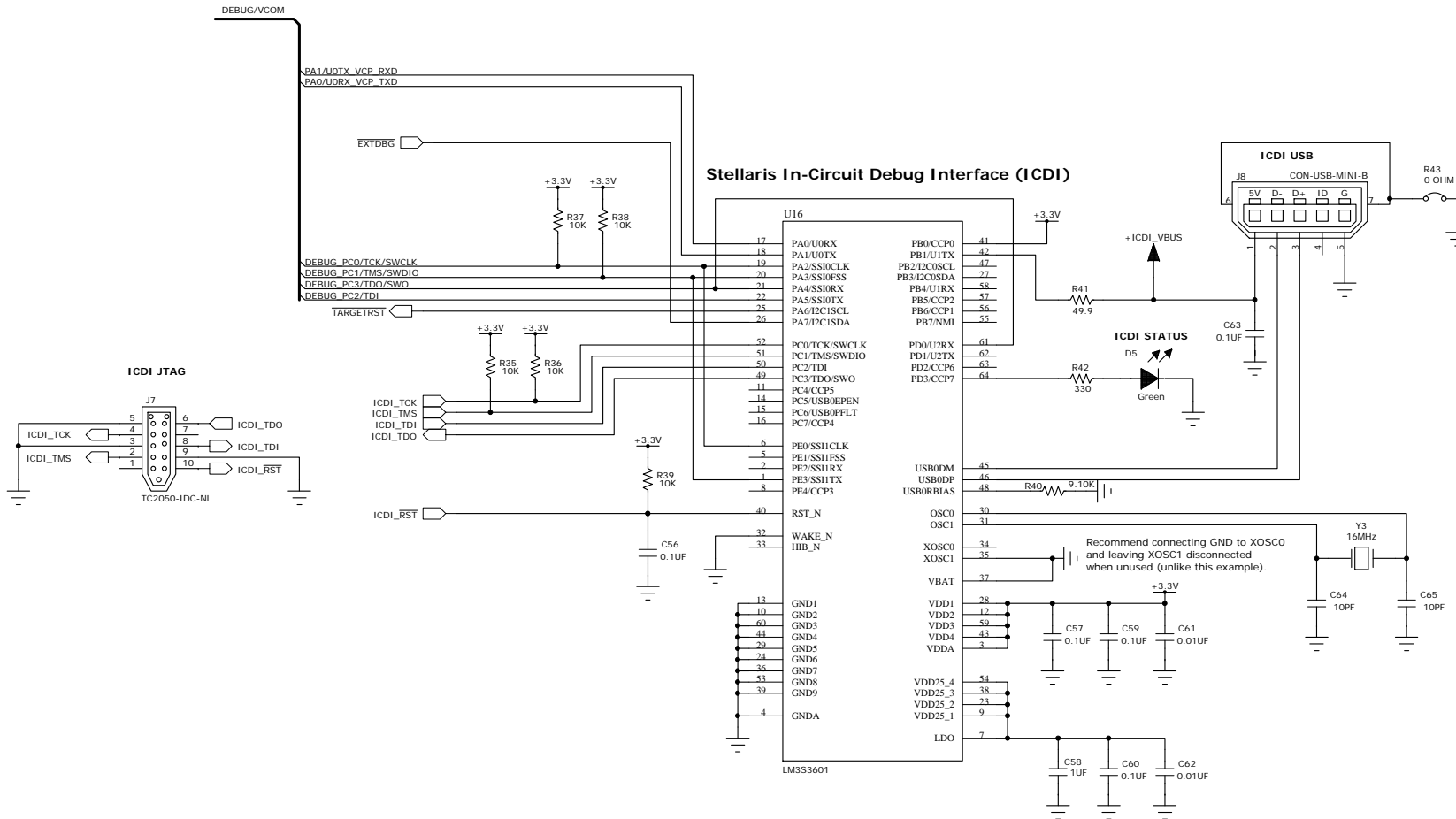

DESIGNER DAY	REVISION A	DATE 10/26/2012
PROJECT LM4F232H5QD Evaluation Kit		
DESCRIPTION Stellaris In Circuit Debug Interface		
FILENAME Armadillo Rev A.sch		

TEXAS INSTRUMENTS
STELLARIS[®] MICROCONTROLLERS

108 WILD BASIN ROAD, SUITE 350
AUSTIN TX, 78746
www.ti.com/stellaris

PART NO. EK-LM4F232	SHEET 4 OF 5
------------------------	-----------------

Chipcon Wireless EM Connector

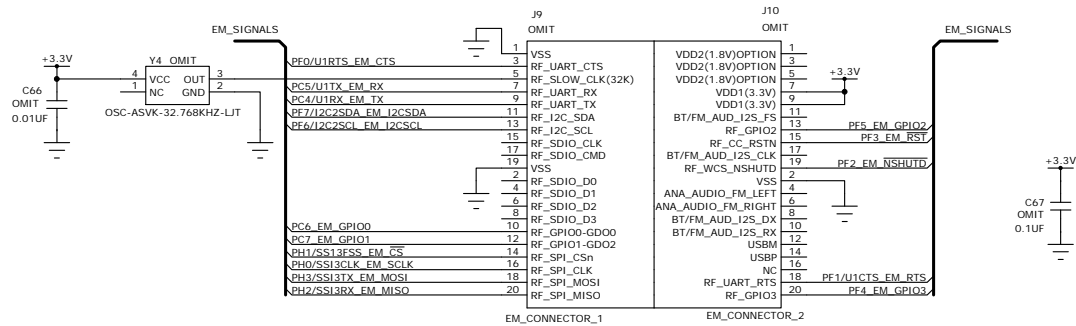

Not installed or supported.

DESIGNER DAY	REVISION A	DATE 10/26/2012
PROJECT LM4F232H5QD Evaluation Kit		
DESCRIPTION Chipcon Wireless EM Connector (Not Installed)		
FILENAME Armadillo Rev A.sch		

	TEXAS INSTRUMENTS STELLARIS [®] MICROCONTROLLERS 108 WILD BASIN ROAD, SUITE 350 AUSTIN TX, 78746 www.ti.com/stellaris	
	PART NO. EK-LM4F232	SHEET 5 OF 5

APPENDIX B

Component Locations

Plots of the top-side and bottom-side component locations are shown in Figure B-1 and Figure B-2.

Figure B-1. EK-LM4F232 Component Locations (Top View)

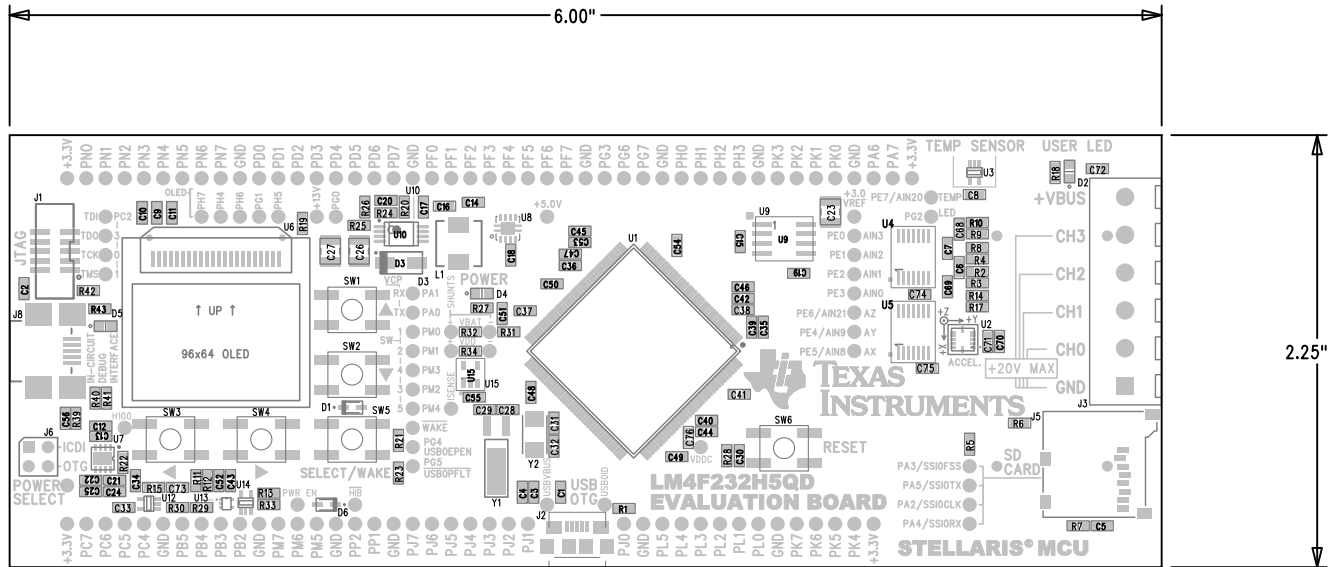
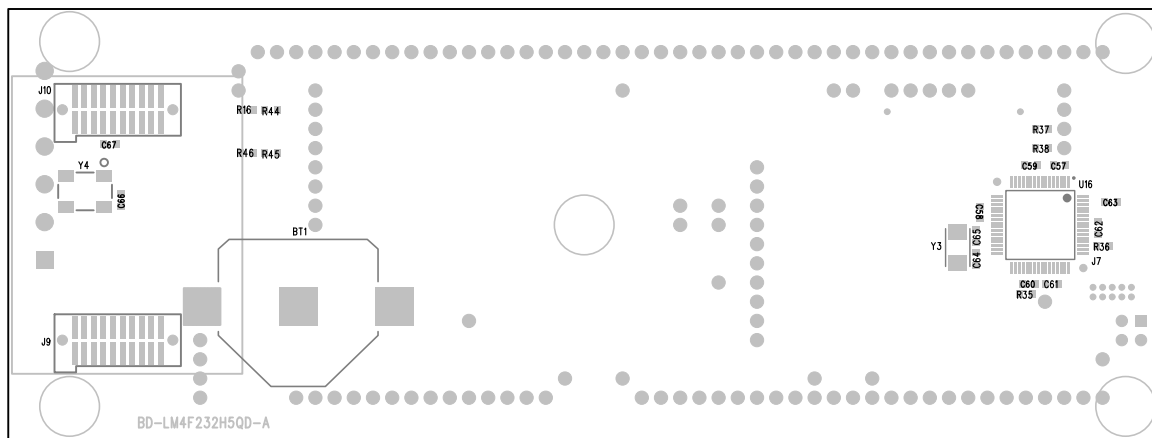

Figure B-2. EK-LM4F232 Component Locations (Bottom View)



A P P E N D I X C

Bill of Materials (BOM)

Table C-1 shows the Bill of Materials for the EK-LM4F232 evaluation board.

Table C-1. EK-LM4F232 Bill of Materials (BOM)

Item	Reference	Qty	Description	Mfg	Part Number
1	BT1	1	Battery Holder, CR2032, SMT	Keystone	3002TR
				Keystone	3002TR
2	C2 C5 C8 C12 C17 C34-36 C40 C42-43 C45 C48-50 C52 C55-57 C59-60 C63 C71-75	27	Capacitor, 0.1uF 50V, 10% 0603 X7R	Murata	GRM188R71H104 KA93D
3	C20	1	Capacitor, 820pF, 50V, 5%, 0603, COG	TDK	C1608C0G1H821J
4	C23 C26-27	3	Capacitor, 10uF, 50V, -20% +80%, 1210, Y5V	Murata	GRM32DF51H106 ZA01L
5	C29 C28	2	Capacitor, 24pF, 50V, 5%, 0603, COG	TDK	C1608C0G1H240J
6	C31-32 C64-65	4	Capacitor, 10pF 50V 5% Ceramic NPO/COG 0603	Kemet	C0603C100J5GAC TU
				Kemet	C0603C100J5RAC TU
7	C33	1	Capacitor, 200pF, 50V, 5%, 0603, COG	TDK	C1608C0G1H201J
8	C41 C37-39 C70 C18 C61-62	8	Capacitor, 0.01uF 50V 5% 0603 X7R	Kemet	C0603C103J5RAC TU
9	C58 C1 C3-4 C13-16 C19 C21-22 C24-25 C44 C46-47 C53-54 C76	19	Capacitor, 1.0uF 25V 10% X5R 0603	TDK	C1608X5R1E105K
				TDK	C1608X5R1E105K
10	C6-7 C68-69	4	Capacitor, 120pF, 50V, 5%, 0603, COG	TDK	C1608C0G1H121J
11	C9-11	3	Capacitor, 4.7uF 25V 10% 0805 X5R	Murata	GRM21BR61E475 KA12L
12	D1 D6	2	Diode, Fast Switching, 80V, 250mA, SOD-323	Diodes Inc	1N4448HWS-7-F

Table C-1. EK-LM4F232 Bill of Materials (BOM) (Continued)

Item	Reference	Qty	Description	Mfg	Part Number
13	D2 D4-5	3	LED, Green 565nm, Clear 0805 SMD	Lite-On	LTST-C171GKT
				Lite-On	LTST-C171GKT
14	D3	1	Diode, Schottky, 20V, 1A	Taiwan Semiconductor	SS12
15	J1	1	Header 2x5, 0.050, SM, Vertical Shrouded	Samtec	SHF-105-01-S-D-SM
				Don Connex Electronics	C44-10BSA1-G
16	J2	1	Connector, USB micro AB Receptacle SMD	Hirose	ZX62-AB-5PA
17	J3	1	Terminal, Screw, 5mm, 6 Pos	Molex	0395430006
				Molex	0395430006
18	J5	1	Connector, Micro SD card, push-push SMT	3M	2908-05WB-MG
19	J6	1	Header, 2x2, 0.100, T-Hole, Vertical Unshrouded, 0.230 Mate	FCI	67997-104HLF
				4UCON	00998
20	J8	1	Connector, USB Mini-B SMT 5pin	Molex	54819-0572
21	L1	1	Inductor, 3.3uH, SMD, 6mm x 6mm, 1.7A, 0.044 Ohm	Panasonic	ELL-6PG3R3N
22	R1 R43	2	Resistor, 0 OHM 1/10W 0603 SMD	Panasonic	ERJ-3GEY0R00V
23	R12	1	Resistor, 20K OHM 1/10W 5% 0603 Thick	Yageo	RC0603JR-0720KL
24	R13 R19	2	Resistor, 1M OHM 1/10W 5% 0603 SMD	Panasonic	ERJ-3GEYJ105V
25	R2 R4 R9 R14	4	Resistor, 105.0K Ohm, 1/10W, 0.1%, 0603, Thin	Susumu	RG1608P-1053-B-T5
26	R24	1	Resistor, 36.5K Ohm, 1/10W, 1%, 0603, Thick	Yageo	RC0603FR-0736K5L
27	R25	1	Resistor, 174K Ohm, 1/10W, 1%, 0603, Thick	Yageo	RC0603FR-07174KL
28	R26 R10 R8 R3 R17	5	Resistor, 18.00K Ohm, 1/10W, 0.1%, 0603, Thin	Panasonic	ERA-3AEB183V
29	R27 R18 R42	3	Resistor, 330 OHM 1/10W 5% 0603 SMD	Panasonic	ERJ-3GEYJ331V
30	R29	1	Resistor, 9.53M Ohm, 1/10W, 1%, 0603, Thick	Vishay	CRCW06039M53FKEA

Table C-1. EK-LM4F232 Bill of Materials (BOM) (Continued)

Item	Reference	Qty	Description	Mfg	Part Number
31	R30	1	Resistor, 6.8M Ohm, 1/10W, 5%, 0603, Thick	Yageo	RC0603JR-076M8L
32	R31	1	Resistor, 220K Ohm, 1/10W, 1%, SMD, Thick	Panasonic	ERJ-3EKF2203V
33	R32-33	2	Resistor, 1K OHM 1/10W 1% 0603 Thick	Panasonic	ERJ-3EKF1001V
34	R34	1	Resistor, 0.1 Ohm, 1/10W, 1%, 0603, Thick	Panasonic	ERJ-3RSFR10V
35	R40	1	Resistor, 9.1K OHM 1/10W 1% 0603 Thick	Panasonic	ERJ-3EKF9101V
36	R41	1	Resistor, 49.9 OHM 1/10W 1% 0603 Thick	Panasonic	ERJ-3EKF49R9V
37	R5-7 R11 R15 R20-23 R28 R35-39	15	Resistor, 10K OHM 1/10W 5% 0603 SMD	Panasonic	ERJ-3GEYJ103V
38	SW1-6	6	Switch, Tact 6mm SMT, 160gf	Omron	B3S-1000
39	U1	1	Stellaris, LM4F232H5QDFIGA1	Texas Instruments	LM4F232H5QDFIG A1
40	U10	1	Regulator, 2.3V - 6V in, 18.5Vout max, 2.0A	Texas Instruments	TPS61085PW
41	U12	1	IC, Single Voltage Detector, Adjustable, 5-SC70(DCK)	Texas Instruments	TPS3803-01DCKR
42	U13	1	IC, Single 2-input OR-Gate, 5SOT(DRL)	Texas Instruments	SN74AHCT1G32D RLR
43	U14	1	IC, Single Tri-state Buffer, SC70-5 (DCK)	Texas Instruments	SN74AHC1G125D CKR
44	U15	1	Current Shunt Monitor, INA198, 100V/V Gain, 5SOP(DBV)	Texas Instruments	INA198AIDBVR
45	U16	1	Stellaris MCU, LM3S3601	Texas Instruments	LM3S3601-IQR50
46	U2	1	IC, 3 Axis Analog Accelerometer, +/- 4g	Bosch Sensortec	BMA140
47	U3	1	IC, Analog Temperature Sensor -55C to +130C, +/-2.5C, 5-SC70(DCK)	Texas Instruments	TMP20AIDCKR
48	U4-5	2	Op Amp, 3 MHz, Quad, Rail-to-Rail, 14TSSOP	Texas Instruments	TLV2374IPWR
49	U6	1	OLED Display, 96x64, RGB	Crystalfontz	CFAL9664B-F-B1
50	U7	1	Fault protected power switch, dual channel, 8-SON	Texas Instruments	TPS2052BDRBR

Table C-1. EK-LM4F232 Bill of Materials (BOM) (Continued)

Item	Reference	Qty	Description	Mfg	Part Number
51	U8	1	Regulator, 3.3V, 400mA, LDO	Texas Instruments	TPS73633DRBT
52	U9	1	Precision 3.0V reference SOIC-8	Texas Instruments	REF5030AID
53	Y1	1	Crystal, 32.768KHz Radial Can	Abracon	AB26TRB-32.768KHZ-T
54	Y2-3	2	Crystal, 16.00MHz 5.0x3.2mm SMT	NDK	NX5032GA-16.000000MHZ
55	PCB1	1	PCB for EK-LM4F232H5QD FR-4 6-layer ENIG Rev A		
PCB Do Not Populate List (Shown for information only)					
56	C30 C51 C67	3	Capacitor, 0.1uF 50V, 10% 0603 X7R	Murata	GRM188R71H104KA93D
57	C66	1	Capacitor, 0.01uF 50V 5% 0603 X7R	Kemet	C0603C103J5RAC TU
58	J9, J10	2	Header, 2x10, 0.050, SMT, Vertical, Shrouded, Socket	Samtec	TFM-110-02-S-D-K-A
59	R16 R44-46	4	Resistor, 0 OHM 1/10W 0603 SMD	Panasonic	ERJ-3GEY0R00V
60	Y4	1	Oscillator, 32.768 kHz, SMT	Abracon	ASVK-32.768KHZ-LJT
Final Assembly Bill Of Materials					
61	Z1	1	Battery, Lithium, CR2032, Non-Rechargeable	Panasonic	CR2032
62	Z2	1	Jumper, 0.100, Gold, Black, Closed	Sullins	SPC02SYAN
63	Z3-7	5	Rubber Feet, Adhesive, Round, 0.312 x 0.200	3M	SJ-61A1

References

In addition to this document, the following references are included on the Stellaris LM4F232H5QD Evaluation Kit CD and are also available for download at www.ti.com.

- *Stellaris LM4F232H5QD Microcontroller Data Sheet*, publication DS-LM4F232H5QD
- StellarisWare Driver Library
- *StellarisWare Driver Library User's Manual*, publication SW-DRL-UG

Additional references include:

- *±2.5°C Low-Power, Analog Out Temperature Sensor Data Sheet (TMP20)*
- *Voltage Output High-Side Measurement Current Shunt Monitor Data Sheet (INA198)*
- *Low Noise, Very Low Drift, Precision Voltage Reference Data Sheet (REF5030)*
- *Current-Limited, Power-Distribution Switches Data Sheet (TPS2052B)*
- *Single Voltage Detector Data Sheet (TPS3803-01)*

The following data sheet can be obtained from the manufacturer:

- *Bosch Sensortec Triaxial, Analog Acceleration Sensor Data Sheet (BMA140)*

Information on development tool being used:

- RealView MDK web site, www.keil.com/arm/rvmdkkit.asp
- IAR Embedded Workbench web site, www.iar.com
- Sourcery CodeBench development tools web site, www.codesourcery.com/gnu_toolchains/arm
- Code Red Technologies development tools web site, www.code-red-tech.com
- Texas Instruments' Code Composer Studio™ IDE web site, www.ti.com/ccs

EVALUATION BOARD/KIT/MODULE (EVM) ADDITIONAL TERMS

Texas Instruments (TI) provides the enclosed Evaluation Board/Kit/Module (EVM) under the following conditions:

The user assumes all responsibility and liability for proper and safe handling of the goods. Further, the user indemnifies TI from all claims arising from the handling or use of the goods.

Should this evaluation board/kit not meet the specifications indicated in the User's Guide, the board/kit may be returned within 30 days from the date of delivery for a full refund. THE FOREGOING LIMITED WARRANTY IS THE EXCLUSIVE WARRANTY MADE BY SELLER TO BUYER AND IS IN LIEU OF ALL OTHER WARRANTIES, EXPRESSED, IMPLIED, OR STATUTORY, INCLUDING ANY WARRANTY OF MERCHANTABILITY OR FITNESS FOR ANY PARTICULAR PURPOSE. EXCEPT TO THE EXTENT OF THE INDEMNITY SET FORTH ABOVE, NEITHER PARTY SHALL BE LIABLE TO THE OTHER FOR ANY INDIRECT, SPECIAL, INCIDENTAL, OR CONSEQUENTIAL DAMAGES.

Please read the User's Guide and, specifically, the Warnings and Restrictions notice in the User's Guide prior to handling the product. This notice contains important safety information about temperatures and voltages. For additional information on TI's environmental and/or safety programs, please visit www.ti.com/esh or contact TI.

No license is granted under any patent right or other intellectual property right of TI covering or relating to any machine, process, or combination in which such TI products or services might be or are used. TI currently deals with a variety of customers for products, and therefore our arrangement with the user is not exclusive. TI assumes no liability for applications assistance, customer product design, software performance, or infringement of patents or services described herein.

REGULATORY COMPLIANCE INFORMATION

As noted in the EVM User's Guide and/or EVM itself, this EVM and/or accompanying hardware may or may not be subject to the Federal Communications Commission (FCC) and Industry Canada (IC) rules.

For EVMs **not** subject to the above rules, this evaluation board/kit/module is intended for use for ENGINEERING DEVELOPMENT, DEMONSTRATION OR EVALUATION PURPOSES ONLY and is not considered by TI to be a finished end product fit for general consumer use. It generates, uses, and can radiate radio frequency energy and has not been tested for compliance with the limits of computing devices pursuant to part 15 of FCC or ICES-003 rules, which are designed to provide reasonable protection against radio frequency interference. Operation of the equipment may cause interference with radio communications, in which case the user at his own expense will be required to take whatever measures may be required to correct this interference.

General Statement for EVMs including a radio

User Power/Frequency Use Obligations: This radio is intended for development/professional use only in legally allocated frequency and power limits. Any use of radio frequencies and/or power availability of this EVM and its development application(s) must comply with local laws governing radio spectrum allocation and power limits for this evaluation module. It is the user's sole responsibility to only operate this radio in legally acceptable frequency space and within legally mandated power limitations. Any exceptions to this are strictly prohibited and unauthorized by Texas Instruments unless user has obtained appropriate experimental/development licenses from local regulatory authorities, which is responsibility of user including its acceptable authorization.

For EVMs annotated as FCC – FEDERAL COMMUNICATIONS COMMISSION Part 15 Compliant

Caution

This device complies with part 15 of the FCC Rules. Operation is subject to the following two conditions: (1) This device may not cause harmful interference, and (2) this device must accept any interference received, including interference that may cause undesired operation.

Changes or modifications not expressly approved by the party responsible for compliance could void the user's authority to operate the equipment.

FCC Interference Statement for Class A EVM devices

This equipment has been tested and found to comply with the limits for a Class A digital device, pursuant to part 15 of the FCC Rules. These limits are designed to provide reasonable protection against harmful interference when the equipment is operated in a commercial environment. This equipment generates, uses, and can radiate radio frequency energy and, if not installed and used in accordance with the instruction manual, may cause harmful interference to radio communications. Operation of this equipment in a residential area is likely to cause harmful interference in which case the user will be required to correct the interference at his own expense.

FCC Interference Statement for Class B EVM devices

This equipment has been tested and found to comply with the limits for a Class B digital device, pursuant to part 15 of the FCC Rules. These limits are designed to provide reasonable protection against harmful interference in a residential installation. This equipment generates, uses and can radiate radio frequency energy and, if not installed and used in accordance with the instructions, may cause harmful interference to radio communications. However, there is no guarantee that interference will not occur in a particular installation. If this equipment does cause harmful interference to radio or television reception, which can be determined by turning the equipment off and on, the user is encouraged to try to correct the interference by one or more of the following measures:

- Reorient or relocate the receiving antenna.
- Increase the separation between the equipment and receiver.
- Connect the equipment into an outlet on a circuit different from that to which the receiver is connected.
- Consult the dealer or an experienced radio/TV technician for help.

For EVMs annotated as IC – INDUSTRY CANADA Compliant

This Class A or B digital apparatus complies with Canadian ICES-003.

Changes or modifications not expressly approved by the party responsible for compliance could void the user's authority to operate the equipment.

Concerning EVMs including radio transmitters

This device complies with Industry Canada licence-exempt RSS standard(s). Operation is subject to the following two conditions: (1) this device may not cause interference, and (2) this device must accept any interference, including interference that may cause undesired operation of the device.

Concerning EVMs including detachable antennas

Under Industry Canada regulations, this radio transmitter may only operate using an antenna of a type and maximum (or lesser) gain approved for the transmitter by Industry Canada. To reduce potential radio interference to other users, the antenna type and its gain should be so chosen that the equivalent isotropically radiated power (e.i.r.p.) is not more than that necessary for successful communication.

This radio transmitter has been approved by Industry Canada to operate with the antenna types listed in the user guide with the maximum permissible gain and required antenna impedance for each antenna type indicated. Antenna types not included in this list, having a gain greater than the maximum gain indicated for that type, are strictly prohibited for use with this device.

Cet appareil numérique de la classe A ou B est conforme à la norme NMB-003 du Canada.

Les changements ou les modifications pas expressément approuvés par la partie responsable de la conformité ont pu vider l'autorité de l'utilisateur pour actionner l'équipement.

Concernant les EVMs avec appareils radio

Le présent appareil est conforme aux CNR d'Industrie Canada applicables aux appareils radio exempts de licence. L'exploitation est autorisée aux deux conditions suivantes : (1) l'appareil ne doit pas produire de brouillage, et (2) l'utilisateur de l'appareil doit accepter tout brouillage radioélectrique subi, même si le brouillage est susceptible d'en compromettre le fonctionnement.

Concernant les EVMs avec antennes détachables

Conformément à la réglementation d'Industrie Canada, le présent émetteur radio peut fonctionner avec une antenne d'un type et d'un gain maximal (ou inférieur) approuvé pour l'émetteur par Industrie Canada. Dans le but de réduire les risques de brouillage radioélectrique à l'intention des autres utilisateurs, il faut choisir le type d'antenne et son gain de sorte que la puissance isotrope rayonnée équivalente (p.i.r.e.) ne dépasse pas l'intensité nécessaire à l'établissement d'une communication satisfaisante.

Le présent émetteur radio a été approuvé par Industrie Canada pour fonctionner avec les types d'antenne énumérés dans le manuel d'usage et ayant un gain admissible maximal et l'impédance requise pour chaque type d'antenne. Les types d'antenne non inclus dans cette liste, ou dont le gain est supérieur au gain maximal indiqué, sont strictement interdits pour l'exploitation de l'émetteur.

【Important Notice for Users of this Product in Japan】

This development kit is NOT certified as Confirming to Technical Regulations of Radio Law of Japan

If you use this product in Japan, you are required by Radio Law of Japan to follow the instructions below with respect to this product:

1. Use this product in a shielded room or any other test facility as defined in the notification #173 issued by Ministry of Internal Affairs and Communications on March 28, 2006, based on Sub-section 1.1 of Article 6 of the Ministry's Rule for Enforcement of Radio Law of Japan,
2. Use this product only after you obtained the license of Test Radio Station as provided in Radio Law of Japan with respect to this product, or
3. Use of this product only after you obtained the Technical Regulations Conformity Certification as provided in Radio Law of Japan with respect to this product. Also, please do not transfer this product, unless you give the same notice above to the transferee. Please note that if you could not follow the instructions above, you will be subject to penalties of Radio Law of Japan.

Texas Instruments Japan Limited
(address) 24-1, Nishi-Shinjuku 6 chome, Shinjuku-ku, Tokyo, Japan

<http://www.tij.co.jp>

【ご使用にあたっての注】

本開発キットは技術基準適合証明を受けておりません。

本製品のご使用に際しては、電波法遵守のため、以下のいずれかの措置を取っていただく必要がありますのでご注意ください。

1. 電波法施行規則第6条第1項第1号に基づく平成18年3月28日総務省告示第173号で定められた電波暗室等の試験設備でご使用いただく。
2. 実験局の免許を取得後ご使用いただく。
3. 技術基準適合証明を取得後ご使用いただく。

なお、本製品は、上記の「ご使用にあたっての注意」を譲渡先、移転先に通知しない限り、譲渡、移転できないものとします。

上記を遵守頂けない場合は、電波法の罰則が適用される可能性があることをご留意ください。

日本テキサス・インスツルメンツ株式会社
東京都新宿区西新宿6丁目24番1号
西新宿三井ビル

<http://www.tij.co.jp>

EVALUATION BOARD/KIT/MODULE (EVM) WARNINGS, RESTRICTIONS AND DISCLAIMERS

For Feasibility Evaluation Only, in Laboratory/Development Environments. Unless otherwise indicated, this EVM is not a finished electrical equipment and not intended for consumer use. It is intended solely for use for preliminary feasibility evaluation in laboratory/development environments by technically qualified electronics experts who are familiar with the dangers and application risks associated with handling electrical mechanical components, systems and subsystems. It should not be used as all or part of a finished end product.

Your Sole Responsibility and Risk. You acknowledge, represent and agree that:

1. You have unique knowledge concerning Federal, State and local regulatory requirements (including but not limited to Food and Drug Administration regulations, if applicable) which relate to your products and which relate to your use (and/or that of your employees, affiliates, contractors or designees) of the EVM for evaluation, testing and other purposes.
2. You have full and exclusive responsibility to assure the safety and compliance of your products with all such laws and other applicable regulatory requirements, and also to assure the safety of any activities to be conducted by you and/or your employees, affiliates, contractors or designees, using the EVM. Further, you are responsible to assure that any interfaces (electronic and/or mechanical) between the EVM and any human body are designed with suitable isolation and means to safely limit accessible leakage currents to minimize the risk of electrical shock hazard.
3. You will employ reasonable safeguards to ensure that your use of the EVM will not result in any property damage, injury or death, even if the EVM should fail to perform as described or expected.
4. You will take care of proper disposal and recycling of the EVM's electronic components and packing materials.

Certain Instructions. It is important to operate this EVM within TI's recommended specifications and environmental considerations per the user guidelines. Exceeding the specified EVM ratings (including but not limited to input and output voltage, current, power, and environmental ranges) may cause property damage, personal injury or death. If there are questions concerning these ratings please contact a TI field representative prior to connecting interface electronics including input power and intended loads. Any loads applied outside of the specified output range may result in unintended and/or inaccurate operation and/or possible permanent damage to the EVM and/or interface electronics. Please consult the EVM User's Guide prior to connecting any load to the EVM output. If there is uncertainty as to the load specification, please contact a TI field representative. During normal operation, some circuit components may have case temperatures greater than 60°C as long as the input and output are maintained at a normal ambient operating temperature. These components include but are not limited to linear regulators, switching transistors, pass transistors, and current sense resistors which can be identified using the EVM schematic located in the EVM User's Guide. When placing measurement probes near these devices during normal operation, please be aware that these devices may be very warm to the touch. As with all electronic evaluation tools, only qualified personnel knowledgeable in electronic measurement and diagnostics normally found in development environments should use these EVMs.

Agreement to Defend, Indemnify and Hold Harmless. You agree to defend, indemnify and hold TI, its licensors and their representatives harmless from and against any and all claims, damages, losses, expenses, costs and liabilities (collectively, "Claims") arising out of or in connection with any use of the EVM that is not in accordance with the terms of the agreement. This obligation shall apply whether Claims arise under law of tort or contract or any other legal theory, and even if the EVM fails to perform as described or expected.

Safety-Critical or Life-Critical Applications. If you intend to evaluate the components for possible use in safety critical applications (such as life support) where a failure of the TI product would reasonably be expected to cause severe personal injury or death, such as devices which are classified as FDA Class III or similar classification, then you must specifically notify TI of such intent and enter into a separate Assurance and Indemnity Agreement.

Mailing Address: Texas Instruments, Post Office Box 655303, Dallas, Texas 75265
Copyright © 2012, Texas Instruments Incorporated

IMPORTANT NOTICE

Texas Instruments Incorporated and its subsidiaries (TI) reserve the right to make corrections, enhancements, improvements and other changes to its semiconductor products and services per JESD46, latest issue, and to discontinue any product or service per JESD48, latest issue. Buyers should obtain the latest relevant information before placing orders and should verify that such information is current and complete. All semiconductor products (also referred to herein as "components") are sold subject to TI's terms and conditions of sale supplied at the time of order acknowledgment.

TI warrants performance of its components to the specifications applicable at the time of sale, in accordance with the warranty in TI's terms and conditions of sale of semiconductor products. Testing and other quality control techniques are used to the extent TI deems necessary to support this warranty. Except where mandated by applicable law, testing of all parameters of each component is not necessarily performed.

TI assumes no liability for applications assistance or the design of Buyers' products. Buyers are responsible for their products and applications using TI components. To minimize the risks associated with Buyers' products and applications, Buyers should provide adequate design and operating safeguards.

TI does not warrant or represent that any license, either express or implied, is granted under any patent right, copyright, mask work right, or other intellectual property right relating to any combination, machine, or process in which TI components or services are used. Information published by TI regarding third-party products or services does not constitute a license to use such products or services or a warranty or endorsement thereof. Use of such information may require a license from a third party under the patents or other intellectual property of the third party, or a license from TI under the patents or other intellectual property of TI.

Reproduction of significant portions of TI information in TI data books or data sheets is permissible only if reproduction is without alteration and is accompanied by all associated warranties, conditions, limitations, and notices. TI is not responsible or liable for such altered documentation. Information of third parties may be subject to additional restrictions.

Resale of TI components or services with statements different from or beyond the parameters stated by TI for that component or service voids all express and any implied warranties for the associated TI component or service and is an unfair and deceptive business practice. TI is not responsible or liable for any such statements.

Buyer acknowledges and agrees that it is solely responsible for compliance with all legal, regulatory and safety-related requirements concerning its products, and any use of TI components in its applications, notwithstanding any applications-related information or support that may be provided by TI. Buyer represents and agrees that it has all the necessary expertise to create and implement safeguards which anticipate dangerous consequences of failures, monitor failures and their consequences, lessen the likelihood of failures that might cause harm and take appropriate remedial actions. Buyer will fully indemnify TI and its representatives against any damages arising out of the use of any TI components in safety-critical applications.

In some cases, TI components may be promoted specifically to facilitate safety-related applications. With such components, TI's goal is to help enable customers to design and create their own end-product solutions that meet applicable functional safety standards and requirements. Nonetheless, such components are subject to these terms.

No TI components are authorized for use in FDA Class III (or similar life-critical medical equipment) unless authorized officers of the parties have executed a special agreement specifically governing such use.

Only those TI components which TI has specifically designated as military grade or "enhanced plastic" are designed and intended for use in military/aerospace applications or environments. Buyer acknowledges and agrees that any military or aerospace use of TI components which have **not** been so designated is solely at the Buyer's risk, and that Buyer is solely responsible for compliance with all legal and regulatory requirements in connection with such use.

TI has specifically designated certain components which meet ISO/TS16949 requirements, mainly for automotive use. Components which have not been so designated are neither designed nor intended for automotive use; and TI will not be responsible for any failure of such components to meet such requirements.

Products

Audio	www.ti.com/audio
Amplifiers	amplifier.ti.com
Data Converters	dataconverter.ti.com
DLP® Products	www.dlp.com
DSP	dsp.ti.com
Clocks and Timers	www.ti.com/clocks
Interface	interface.ti.com
Logic	logic.ti.com
Power Mgmt	power.ti.com
Microcontrollers	microcontroller.ti.com
RFID	www.ti-rfid.com
OMAP Applications Processors	www.ti.com/omap
Wireless Connectivity	www.ti.com/wirelessconnectivity

Applications

Automotive and Transportation	www.ti.com/automotive
Communications and Telecom	www.ti.com/communications
Computers and Peripherals	www.ti.com/computers
Consumer Electronics	www.ti.com/consumer-apps
Energy and Lighting	www.ti.com/energy
Industrial	www.ti.com/industrial
Medical	www.ti.com/medical
Security	www.ti.com/security
Space, Avionics and Defense	www.ti.com/space-avionics-defense
Video and Imaging	www.ti.com/video

TI E2E Community

e2e.ti.com

Mouser Electronics

Authorized Distributor

Click to View Pricing, Inventory, Delivery & Lifecycle Information:

[Texas Instruments:](#)

[EKI-LM4F232](#) [EKS-LM4F232](#) [EKK-LM4F232](#)