

# Tiva™ TM4C129X Development Board

## User's Guide



Literature Number: SPMU360  
October 2013

---



---



---

<b>1</b>	<b>DK-TM4C129X Overview</b>	<b>4</b>
1.1	Kit Contents	5
1.2	Using the DK-TM4C129X	5
1.3	Features	5
1.4	Specifications	6
<b>2</b>	<b>Hardware Description</b>	<b>7</b>
2.1	Functional Description	8
2.1.1	Microcontroller	8
2.1.2	Clocking	8
2.1.3	Reset	8
2.1.4	Debugging and Programming	8
2.1.5	Power	9
2.1.6	USB Host/Device/OTG	10
2.1.7	User Buttons and User LED	10
2.1.8	Headers	11
2.1.9	Speaker	14
2.1.10	EEPROM and SD Card	14
2.1.11	Temperature Sensor	15
2.1.12	LCD	15
2.1.13	Ethernet	17
2.1.14	Hibernation	17
<b>3</b>	<b>Software Development</b>	<b>18</b>
3.1	Software Description	18
3.2	Source Code	18
3.3	Tool Options	18
3.4	Programming the DK-TM4C129X Board	18
<b>A</b>	<b>Component Locations</b>	<b>20</b>
<b>B</b>	<b>Bill of Materials (BOM)</b>	<b>23</b>
<b>C</b>	<b>References</b>	<b>27</b>
<b>D</b>	<b>Schematics</b>	<b>28</b>

## List of Figures

1-1.	Board Picture .....	4
2-1.	DK-TM4C129X Development Board Block Diagram .....	7
2-2.	Booster Pack 1.....	11
2-3.	Booster Pack 2.....	12
2-4.	ULPI, MII, and RMII .....	13
2-5.	Resistive Touch Screen .....	16
2-6.	LCD Pin Out.....	16
A-1.	DK-TM4C129X Component Locations (Top View).....	20
A-2.	DK-TM4C129X Component Locations (Bottom View).....	21
A-3.	Jumper and Shunt Locations .....	22

## List of Tables

1-1.	DK-TM4C129X Specifications.....	6
2-1.	JTAG Pin Table .....	9
2-2.	USB Host/Device/OTG Signals .....	10
2-3.	User Buttons and LED Pins .....	10
2-4.	J28.....	13
2-5.	J27.....	14
2-6.	J34.....	17

## DK-TM4C129X Overview

The Tiva TM4C129X development kit is an evaluation platform for the Tiva TM4C129x-series ARM® Cortex™-M4-based microcontrollers. The evaluation board's design highlights the TM4C129X microcontroller's USB 2.0 On-The-Go/Host/Device (OTG/Host/Device) interface, the 10BASE-T/100BASE-TX Ethernet controller with internal PHY, QuadSSI bus to communicate with an external flash device, 12-bit Analog-to-Digital Converter (ADC), LCD controller, and the I2C module.

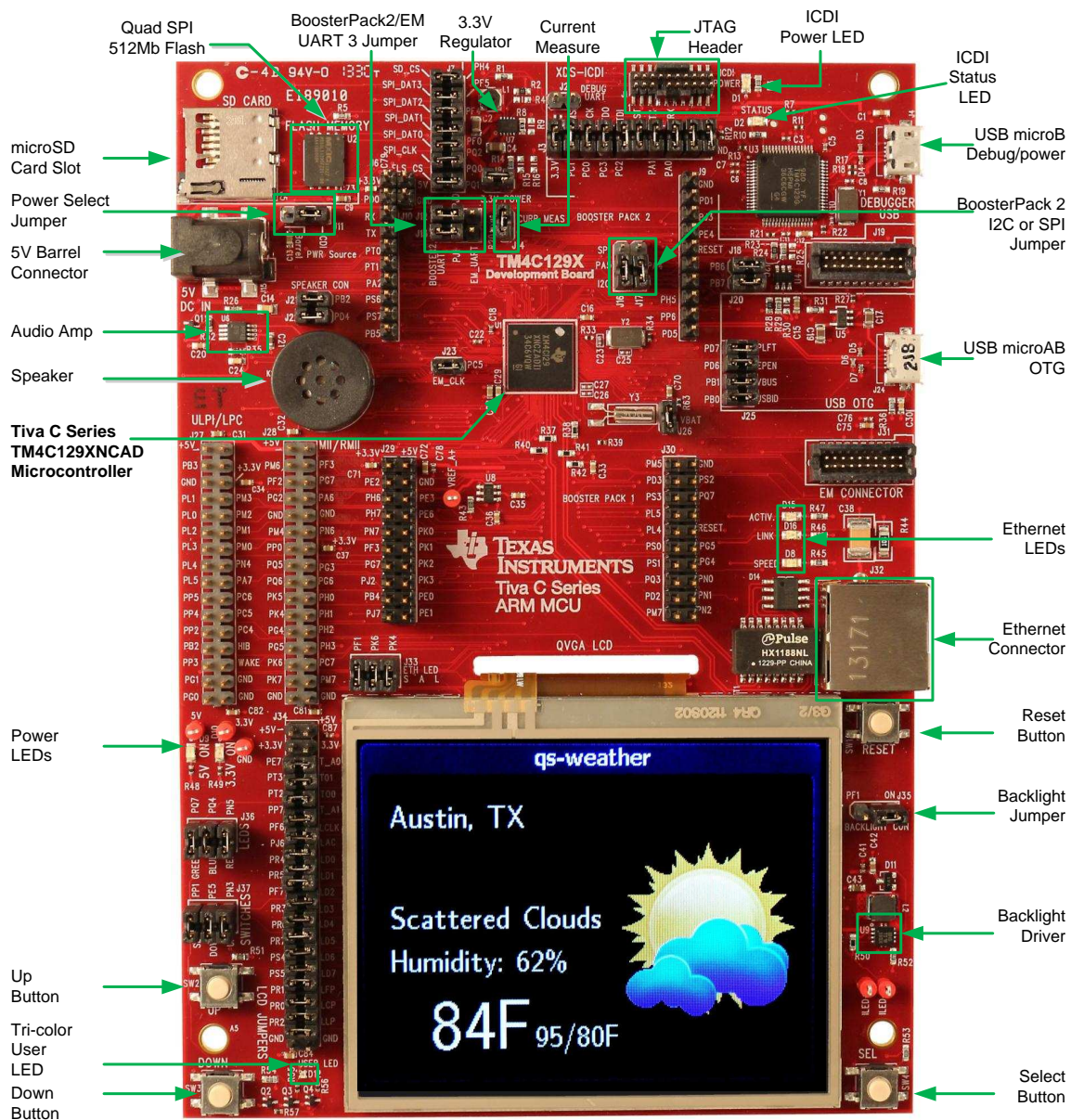

Figure 1-1. Board Picture

All trademarks are the property of their respective owners.

## 1.1 Kit Contents

The DK-TM4C129X Development Kit comes with the following:

- DK-TM4C129X development board
- On board In-Circuit Debug Interface (ICDI)
- Cables:
  - Two USB Micro-B plug to USB-A plug cables
  - USB Micro-A plug to USB-A receptacle cable
  - Cat5 ethernet cable
- USB Flash drive containing:
  - Complete documentation
  - TivaWare™ for C Series [Peripheral Driver Library](#) and example source code
  - A supported evaluation version of all of the following:
    - Texas Instruments' Code Composer Studio™ IDE
    - Keil™ RealView® Microcontroller Development Kit (MDK-ARM)
    - IAR Embedded Workbench® development tools
    - Sourcery CodeBench™ development tools (time limited)
    - GCC

## 1.2 Using the DK-TM4C129X

The recommended steps for using the DK-TM4C129X development kit are:

1. **Follow the "Getting Started Guide" document included in the kit.** The [Getting Started Guide](#) document will help get the DK-TM4C129X development board up and running in minutes.
2. **Use your preferred ARM tool-chain and the Tiva Peripheral Driver Library to develop an application.** Software applications are loaded using the on-board In-Circuit Debug Interface (ICDI). See Chapter 3, [Software Development](#), for the programming procedure. The [TivaWare Peripheral Driver Library User's Guide](#) contains specific information on software structure and function.
3. **Customize and integrate the hardware to suit an end application.** This user's manual is an important reference for understanding circuit operation and completing hardware modification.

## 1.3 Features

The DK-TM4C129X development kit includes the following features:

- Tiva TM4C129X Microcontroller
  - 32-bit ARM® Cortex™-M4F core
- QVGA color display with resistive touch screen
- 10BASE-T/100BASE-TX controller with internal PHY
- USB Micro-AB connector for Host/Device/OTG
- microSD card slot
- 3 navigation buttons
- User tricolor LED
- Precision 3.0V reference
- Quad SSI to 512 Mbit flash
- BoosterPack XL connector for expansion
- BoosterPack connector for expansion
- EM connector for wireless applications
- Available I/O brought out to headers on 0.1" grid
  - ULPI USB external PHY (for high speed USB 2.0)

- RMII and MII external Ethernet PHY
- EPI, Host bus 16/8
- Debug
  - Tiva In-Circuit Debug Interface (ICDI)
  - Standard 20-pin JTAG header without ETM functionality (debug in and out capable)
- Shunt resistors to measure current on  $V_{DD}$ ,  $V_{BAT}$ ,  $V_{DDA}$  and  $V_{REF}$  to the TM4C129X
- Reset button

## 1.4 Specifications

[Table 1-1](#) shows the specifications for the DK-TM4C129X development board.

**Table 1-1. DK-TM4C129X Specifications**

Parameter	Value
Board supply voltage	4.75-5.25V
Dimensions	6.45" x 4.5" x 0.84" (LxWxH)
RoHS status	Compliant

## Hardware Description

In addition to a TM4C129XNCZAD microcontroller, the evaluation board includes a range of useful peripheral features and an integrated in-circuit debug interface (ICDI). This chapter describes how these peripherals operate and interface to the microcontroller.

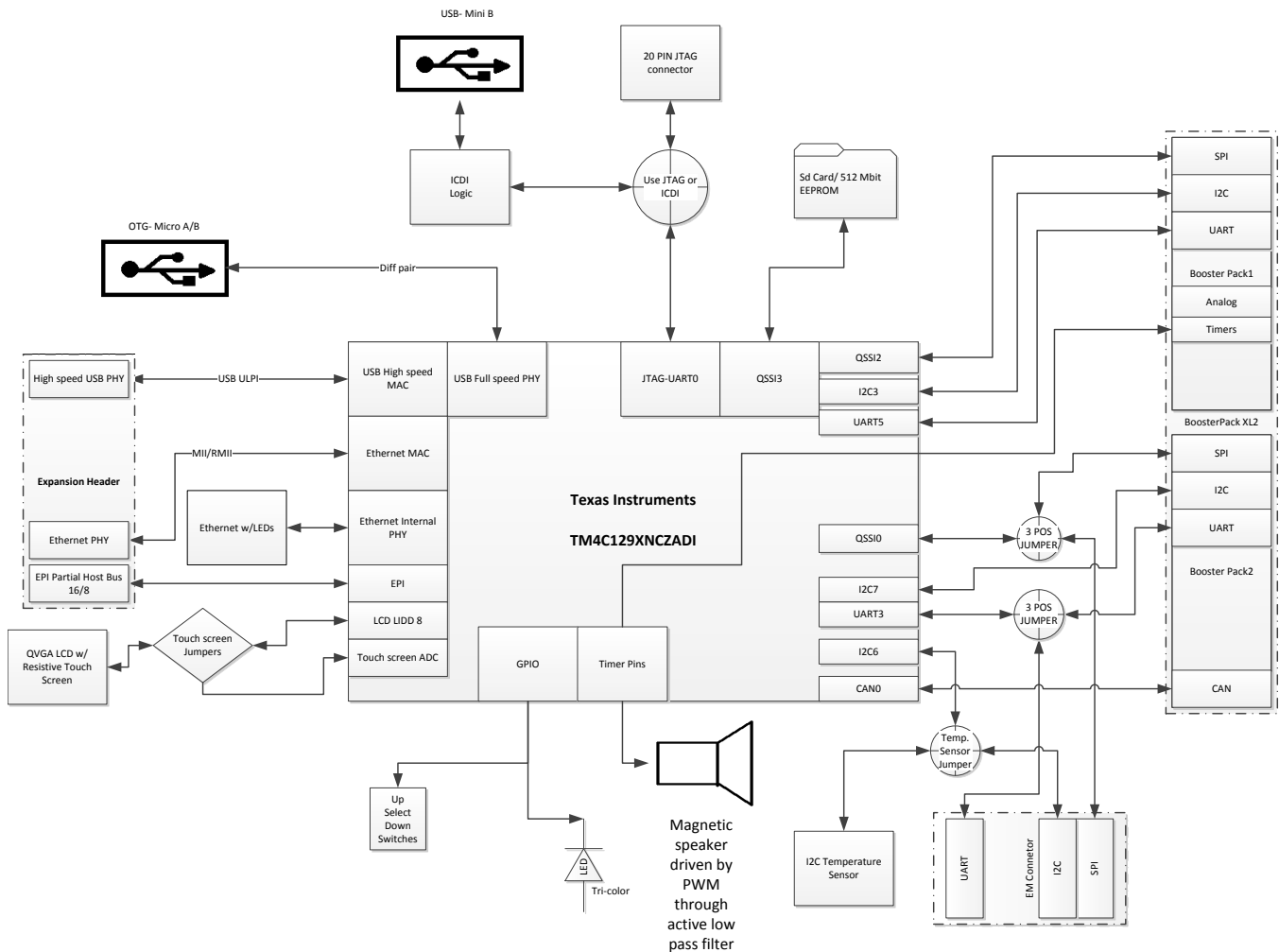

**Figure 2-1. DK-TM4C129X Development Board Block Diagram**

## 2.1 Functional Description

### 2.1.1 Microcontroller

The Tiva TM4C129XNCZAD is an ARM® Cortex™-M4-based microcontroller with 1024-KB flash memory, 256-KB SRAM, 120-MHz operation, USB Host/Device/OTG, Ethernet Controller, Intergrated Ethernet PHY, Hibernation module, and a wide range of other peripherals. See the [TM4C129XNCZAD](#) microcontroller data sheet for complete device details.

Most of the microcontroller signals are routed to 0.1" pitch break-out pads and labeled with their GPIO reference. An internal multiplexer allows different peripheral functions to be assigned to each of these GPIO pads. When adding external circuitry, consideration should be given to the additional load on the development board's power rails. The [Tiva PinMux Utility](#) can be used to quickly develop pin assignments and the code required to configure them.

The TM4C129XNCZAD microcontroller is factory-programmed with a quickstart weather display program. The quickstart program resides in on-chip flash memory and runs each time power is applied, unless the application has been replaced with a user program.

### 2.1.2 Clocking

The DK-TM4C129X uses a 25.0-MHz crystal (Y2) to complete the TM4C129XNCZAD microcontroller's main internal clock circuit. An internal PLL, configured in software, can be used to multiply this clock to higher frequencies for core and peripheral timing.

The Hibernation module is clocked off of an external 32.768 kHz crystal (Y3).

### 2.1.3 Reset

The  $\overline{\text{RST}}$  signal into the TM4C129XNCZAD microcontroller connects to the RESET switch and to the ICDI circuit for a debugger-controlled reset.

External reset is asserted (active low) under any one of these conditions:

- Power-on reset
- RESET switch held down
- By the ICDI circuit when instructed by the debugger (this capability is optional, and may not be supported by all debuggers).

### 2.1.4 Debugging and Programming

- ICDI: The DK-TM4C129X has a built in debugger, which can be used by connection to a computer using the included USB micro-B to USB-A plug cable from the microUSB-B connector (J4) located in the upper right of the board to a USB port on your computer. The on-board ICDI can also be used to debug external boards using the ARM standard 20-pin connector (J1) and pulling all the shunts from J3.
- External debugger: an external debugger can be used through the ARM standard 20 pin connector J1.



**Table 2-1. JTAG Pin Table**

JTAG (J1) Pin	GPIO Pin (U1)	Pin Functions	Jumper J3 Pins
4	PC0	TCK	5, 6
2	PC1	TMS	3, 4
8	PC2	TDI	9, 10
6	PC3	TDO	7, 8
16	PA0	U0RX	13, 14
14	PA1	U0TX	15, 16
10		RESET	11, 12
18		TRST	N/A
1		3.3V (with shunt)	1, 2
3, 11, 15, 17, 19		GND	N/A
9		T_DISCONNECT	19, 20
5		EXTDBG (with shunt)	17, 18
12, 20		Reserved	

**EXTDBG** is a signal that gets pulled low when attached to an external debugger. When pulled low, the JTAG outputs of the ICDI controller are Z-stated.

**T\_DISCONNECT** is a signal used to tell the ICDI when a device is connected to it.

**J2** is a reserved jumper that may add functionality later. Leave unpopulated.

**Note:** The 20-pin connector (J1) is the ARM standard JTAG with ETM functionality connector. While the TM4C129X devices support ETM functionality, this board does not have the necessary circuitry.

### 2.1.5 Power

The board is designed to be powered from one of two sources, they are selected by populating J11 jumper differently. The settings are as follows:

- Setting the shunt between pins 1 and 2 selects the barrel connector (J15) as the main 5-V source.
- Setting the shunt between pins 2 and 3 selects the ICDI USB (J4) as the power source.

J15 is a 6.5-mm diameter center power barrel connector. An example of a functional power supply is *CUI EMSA05300-P6P*.

Power Jumper (J11) Options	
Shunt on pin 1 and 2	Shunt on pin 2 and 3
Powered by J15	Powered by J4

The current and power consumption of the TM4C129X can be calculated by removing the shunt on J14 and measuring the voltage over the two pins, which are connected by a 1-Ω series resistor between the pins. To calculate the current and power, use the following formulas:

$$I_{\text{TM4C129X}} = V_{\text{J14}} / 1\Omega \quad (1)$$

$$P_{\text{TM4C129X}} = V_{\text{J14}}^2 / 1\Omega \quad (2)$$

The TPS62177DQC (U7) switching power regulator has many functions that are configured by omitting resistors and including feedback to change the voltage on the 3.3-V rail. To learn more about these features refer to the [TPS62177DQC](#) data sheet.

To power the external 3.3-V power supply without using the onboard voltage regulator (U7), remove the shunt from J8 and connect 3.3-V directly to pin 1 of J8.

### 2.1.6 USB Host/Device/OTG

The DK-TM4C129X includes a USB Micro-AB (OTG) connector (J24) to allow for USB Host, Device, and OTG operation. [Table 2-2](#) shows the signals that are used for USB OTG:

**Table 2-2. USB Host/Device/OTG Signals**

GPIO Pin	Pin Function	USB OTG
PL6	USB0DP	D+
PL7	USB0DM	D-
PB0	USB0ID	ID
PB1	USB0VBUS	USB VBUS
		<b>Load Switch</b>
PG4	USB0EPEN	USB VBUS Power Enable (EN)
PG5	USB0PFLT	Power Fault (OC)

In USB Host mode, the development board can provide power to the OTG connector. The USB0EPEN signal controls the enable (EN) of a Texas Instruments' TPS20511B Load Switch (U5), which enables power to the connector's VBUS pin.

In Device mode, the development board can be powered from either the ICD1 or the 5-V power supply.

In OTG mode, the USB controller is configured as Host or Device depending on the USB0ID signal and the board is powered appropriately.

### 2.1.7 User Buttons and User LED

Three push buttons on the board provide navigation and selection for some of the example applications. These buttons can be used for other purposes in the user's custom applications.

The development board also has a tri-color user LED.

[Table 2-3](#) shows how these features are connected to the pins on the microcontroller.

**Table 2-3. User Buttons and LED Pins**

Pin	Pin Function	Jumper
PP1	Select SW4	J37 pins 1 and 2
PN3	Up SW2	J37 pins 3 and 4
PE5	Down SW3	J37 pins 5 and 6
PN5	Red LED	J36 pins 1 and 2
PQ4	Blue LED	J36 pins 3 and 4
PQ7	Green LED	J36 pins 5 and 6

## 2.1.8 Headers

The three main sets of headers on the board are on a 0.100" grid and separated for a particular function.

### 2.1.8.1 BoosterPack 1

Figure 2-2 is a BoosterPack XL connection defined in the [BoosterPack Design Guide](#). The port names and voltage rails are listed in the silk screen next to the pin of the header.

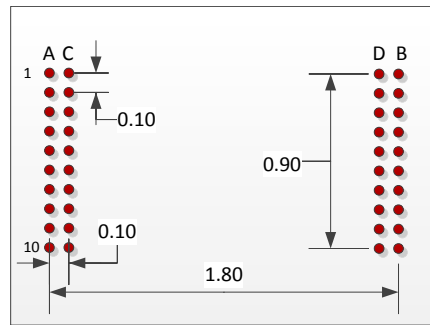

**Figure 2-2. Booster Pack 1**

J29				J30			
CON A	Booster Function	TM4C129X Port	DK Function	CON B	Booster Function	TM4C129X Port	DK Function
1	3.3V	N/A	GND	1	GND	N/A	
2	Analog In	PE2	AIN01	2	Timer Output	PS2	T3CCP0
3	UART RX	PH6	U5RX	3	INT. GPIO	PQ7	
4	UART TX	PH7	U5TX	4	Test	N/A	NC
5	Int. GPIO	PN7	PN7	5	RESET	RESET	RESET
6	SPI A CLK	PF3	SSI3CLK	6	SPI_B_SIMO	PG5	SSI2XDAT0/ I2C3SDA
7	SPI B CLK	PG7	SSI2CLK	7	SPI_B_SOMI	PG4	SSI2DAT1/ I2C3CL
8	GPIO	PJ2		8	GPIO	PN0	PN0
9	GPIO	PB4		9	GPIO	PN1	PN1
10	GPIO	PJ7		10	GPIO	PN2	PN2
CON C	Booster Function	TM4C129X Port	DK Function	CON D	EM Function	TM4C129X Port	DK Function
1	5V	N/A		1	Timer Output	PM5	T4CCP1
2	GND			2	Timer Output	PD3	T1CCP1
3	Analog IN	PE3	AIN00	3	Timer Output	PS3	T3CCP1
4	Analog IN	PE6	AIN20	4	Timer Output	PL5	T0CCP1
5	Analog IN	PK0	AIN16	5	Timer Output	PL4	T0CCP0
6	Analog IN	PK1	AIN17	6	Timer Output	PS0	T2CCP0
7	Analog IN	PK2	AIN18	7	Timer Output	PS1	T2CCP1
8	Analog IN	PK3	AIN19	8	Timer Output	PQ3	T7CCP1
9	Analog IN	PE0	AIN03	9	Timer Output		NC
10	Analog IN	PE1	AIN02	10	Timer Output	PM7	T5CCP1

### 2.1.8.2 BoosterPack 2

Figure 2-3 is a standard 20-pin BoosterPack (defined in the [BoosterPack Design Guide](#)). The port name, functionality, and voltage rail are printed on the silk screen near the pin. For the BoosterPack 2 UART port, the following jumpers must be set: J10 and J12 must have the shunts moved to pins 2 and 3 (this is the side that says BOOSTER2 UART). For SPI, set jumpers J17 and J16 to pin 1 and 2, respectively; for I2C, set jumpers 16 and 17 to pins 2 and 3.

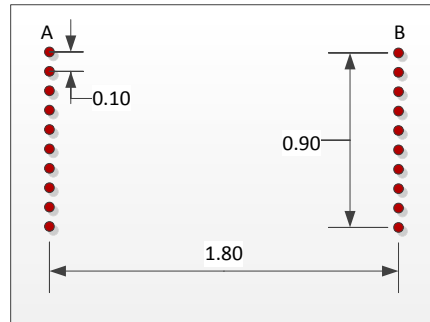
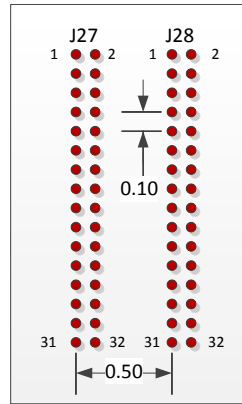

Figure 2-3. Booster Pack 2

J6				J9			
CON A	Booster Function	TM4C129X	DK Function	CON B	Booster Function	TM4C129X	DK Function
1	3.3V	N/A	GND	1	GND	N/A	
2	Analog In	PD0	AIN15	2	Timer Output	PD1	TOCCP0
3	UART RX	J12	Jumper	3	INT. GPIO	PQ0	
4	UART TX	J13	Jumper	4	Test	N/A	NC
5	INT. GPIO	PQ1	PQ1	5	RESET	RESET	RESET
6	SPI A CLK	PF3	SSI3CLK	6	SPI_B_SIMO	J17/J16	Jumper
7	SPI B CLK	PA2	SSI0CLK	7	SPI_B_SOMI	J16/J17	Jumper
8	GPIO	PS6		8	GPIO	PQ2	PQ2
9	GPIO	PS7		9	GPIO	PN1	PP6
10	GPIO	PT0		10	GPIO	PN2	PT1

### 2.1.8.3 ULPI, MII, RMII, and EPI

There are two 16x2 headers on the left side of the board (J28 and J27). The majority of the J28 pins are for MII and RMII signals, and the majority of J27 pins are for ULPI (an external USB PHY). Shared between J28 and J27 are the connections for an EPI (host bus 16/8). There are also ground, +5V, +3.3V, Hibernate and Wake pins mixed in with the connectors. Both headers are on a 100 mil grid.



**Figure 2-4. ULPI, MII, and RMII**

**Table 2-4. J28**

PIN	PORT	FUNCTION	PIN	PORT	FUNCTION
1	5V		2	NC	
3	PM6	EN0CRS	4	PF3	EN0MDIO
5	PF2	EN0MDC	6	PG7	EN0RXDV
7	PG2	EN0TXCLK	8	PA6	EN0RXCK/EPI0S8
9	GND	Ground	10	GND	
11	PM4	EN0RREFCLK	12	PN6	EN0TXER
13	PP0	EN0INTRN	14	3.3V	
15	PQ5	EN0RXD0	16	PG3	EN0TXEN
17	PQ6	EN0RXD1	18	PG6	EN0RXER
19	PK5	EN0RXD2/EPI0S31/EN0LED2	20	PH0	EPI0S00
21	PK4	EN0RXD3/EPI0S32/EN0LED0	22	PH1	EPI0S01
23	PG4	EN0TXD0	24	PH2	EPI0S02
25	PG5	EN0TXD1	26	PH3	EPI0S03
27	PK6	EN0TXD2/EPI0S25/EN0LED1	28	PC7	EPI0S04
29	PK7	EN0TXD3/EPI0S24	30	PM7	EN0COL
31	GND	Ground	32	GND	

**Table 2-5. J27**

PIN	PORT	FUNCTION	PIN	PORT	FUNCTION
1	5V		2	NC	
3	PB3	USB0CLK/EPI0S28/EN0MDIO	4	NC	
5	GND		6	3.3V	
7	PL1	USB0D1/EPI0S17	8	PM3	EPI0S12
9	PL0	USB0D0/EPI0S16	10	PM2	EPI0S13
11	PL2	USB0D2/EPI0S18	12	PM1	EPI0S14
13	PL3	USB0D3/EPI0S19	14	PM0	EPI0S15
15	PL4	USB0D4/EPI0S26	16	PN4	EPI0S34
17	PL5	USB0D5/EPI0S23	18	PA7	EPI0S09
19	PP5	USB0D6	20	PC6	EPI0S05
21	PP4	USB0D7	22	PC5	EPI0S06
23	PP2	USB0NXT/EPI0S29	24	PC4	EPI0S07
25	PB2	USB0STP/EPI0S27	26	HIB	
27	PP3	USB0DIR/EPI0S30	28	WAKE	
29	PG1	EPI0S10	30	GND	
31	PG0	EPI0S11	32	GND	

### 2.1.9 Speaker

The speaker circuit is driven by the PWM coming from PB2(T5CCP0) to produce sound. The amplifier (U6) is a Texas Instruments [LM4819](#) and is turned on and off by PD4.

The circuit has two filters: a high-pass filter (C14 and R26) and a low-pass filter (C24 and R35). The high-pass filter removes any DC bias and inaudible frequencies, which the low-pass filter removes the high frequencies from the PWM pulses.

The amplifier is turned off by default; when PD4 is high the amplifier turns on, and when PD4 is low, the amplifier turns off.

### 2.1.10 EEPROM and SD Card

Included on the development kit is a Macronix [MX66L51235F](#) 512 Mb EEPROM (U2) and a microSD card slot (J5).

#### CAUTION

Do not hot plug the SD card, turn off power before adding or removing SD card!

To communicate with these memory devices, use SSI port 3. The EEPROM can use QUAD SSI or standard SSI, while the SD card uses standard SSI.

Port	Function	Jumper J7 pins to shunt
PQ1	EEPROM Chip select	1 and 2
PQ0	SSI 3 Clock (used by EEPROM and SD card)	3 and 4
PQ2	SSI 3 Data 0 (EEPROM) or Data out (SD Card)	5 and 6
PF0	SSI 3 Data 1 (EEPROM) or Data in (SD Card)	7 and 8
PF4	SSI 3 Data 2	9 and 10
PF5	SSI 3 Data 4	11 and 12
PH4	SD card Chip Select	13 and 14

### 2.1.11 Temperature Sensor

The ambient temperature is measured by the Texas Instruments [TMP100](#) temperature sensor (U4), which is connected to the TM4C129X by I2C.

I2C module 6 is used to interface with the temperature sensor, which has a maximum resolution of 12 bits. The TMP100 is accurate to +/- 2 °C within the range of -25 to +85 °C.

The initial value of the I2C slave address is 0b1001010 or 0x4A, code required to configure them. If the default address conflicts with another device you have added to the I2C bus, the address can be changed by populating or unpopulating resistors R29, R30, R24 and/or R25. Refer to the "Serial Bus Address" section of the [TMP100](#) datasheet for the various address settings.

There are 2.2-kΩ pull-up resistors on the SDA and SCL lines as required by the I2C specification. Refer to the following table for connections to I2C temperature sensor:

Port	Function	Jumper to shunt
PB6	I2C6 SCL	J18
PB7	I2C6 SDA	J20

### 2.1.12 LCD

The DK-TM4C129X is equipped with a Kentec K350QVG-V2-F 320x240 RGB resistive touch screen that is controlled by the LCD Controller of the TM4C129X MCU using the LCD Interface Display Driver (LIDD) in 8-bit mode.

The backlight of the LCD is driven by a TI TPS61042 constant current supply (U9). The control line of U9 has multiple settings that are set by moving the shunt on J35.

Shunt Across	Effect
Pins 1 and 2 (default)	Always on
Pins 2 and 3	Backlight control is handled by PF1 (This pin is also used as an Ethernet LED; remove the shunt on pin 5 and 6 for jumper J33)
None	Always off

#### CAUTION

If the LCD is disconnected, remove the shunt, **otherwise the U9 current supply will get very hot and may be damaged.**

The resistive touch screen works by reading one axis at a time. For example, to read the X-axis, set PE7 to high, PT2 to ground, and tri-state PT3. Then read the analog value of PP7. The higher the voltage, the farther left the user is on the touch screen. To read the Y-axis, set PT3 to high, PP7 to ground, and tri-state PT2. Then read the analog value of PE7. The higher the voltage, the higher the user is on the touch screen. Refer to [Figure 2-5](#).

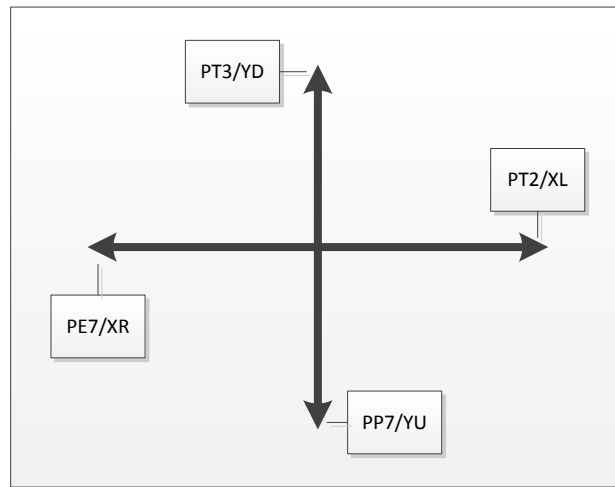
**Figure 2-5. Resistive Touch Screen**

**Note:** The analog input PE7 (AIN21) is under commit control and extra steps are required in software to enable the function of the pin to be changed, see the "Commit Control" section of the datasheet for more information and the software steps required to enable proper operation of the touch screen.

J34 enables the use of another display or other uses of the LCD pins. There are mounting holes under the LCD to facilitate the use and mounting of other displays (refer to [Figure 2-6](#) for dimensions). If the default LCD is used, the default shunts must be in place (shown in [Figure A-3](#)).

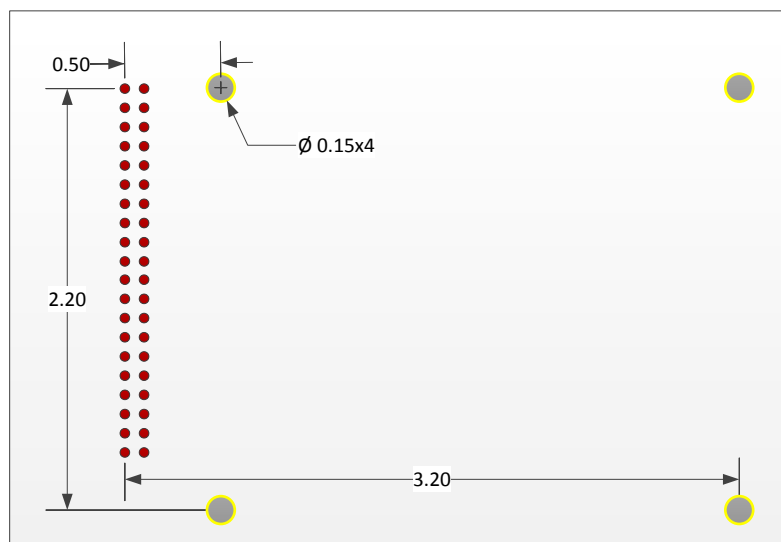
**Figure 2-6. LCD Pin Out**



**Table 2-6. J34**

PIN	PORT	FUNCTION	PIN	LCD PIN NAME	LCD FUNCTION
1	N/A	5V	2	N/A	5V
3	N/A	3.3V	4	N/A	3.3V
5	PE7	AIN21	6	XR	TOUCH ANALOG
7	PT2	GPIO	8	YD	TOUCH IO
9	PT3	GPIO	10	XL	TOUCH IO
11	PP7	AIN22	12	YU	TOUCH ANALOG
13	PF6	LCDMCLK	14	RST	SYSTEM RESET
15	PJ6	LCDAC	16	CS	CHIP SELECT
17	PR4	LCDDATA00	18	D1 & D10	LCD DATA
19	PR5	LCDDATA01	20	D2 & D11	LCD DATA
21	PF7	LCDDATA02	22	D3 & D12	LCD DATA
23	PR3	LCDDATA03	24	D4 & D13	LCD DATA
25	PR6	LCDDATA04	26	D5 & D14	LCD DATA
27	PR7	LCDDATA05	28	D6 & D15	LCD DATA
29	PS4	LCDDATA06	30	D7 & D16	LCD DATA
31	PS5	LCDDATA07	32	D8 & D17	LCD DATA
33	PR1	LCDFP	34	DC	PARALLEL INTERFACE
35	PR0	LCDCP	36	RD	READ SIGNAL
37	PR2	LCDLP	38	WR	WRITE SIGNAL
39	N/A	GND	40	N/A	GND

### 2.1.13 Ethernet

The DK-TM4C129X supports 10/100 Mbps Ethernet through J32. Each DK has been assigned a unique MAC address that is stored in USER\_REG0 and USER\_REG1. The value of the MAC address can be viewed on the Configuration display in the quickstart weather display example. J32 is driven from the internal PHY of the TM4C129XNCZAD and the PHY controls three LED that indicate Link, Activity and Speed. The pins used for the Ethernet LEDs can be used for other functions, but the shunts on jumper J33 must be removed to enable alternative uses. Refer to the following table for pins:

Pin	Function	LED Color	Jumper
PK4	EN0LED0 (Link)	RED	J33, Pins 1 and 2
PK6	EN0LED1 (Activity)	GREEN	J33, Pins 3 and 4
PF1	EN0LED2 (Speed)	AMBER	J33, Pins 5 and 6
RBIAS	RBIAS	--	NO
ENORXIN	ENORXIN	--	NO
ENORXIP	ENORXIP	--	NO
EN0TXON	EN0TXON	--	NO
EN0TXOP	EN0TXOP	--	NO

**Note:** The pin controlling the Speed LED can be used to control the backlight for the LCD, refer to the [LCD section](#) for information.

### 2.1.14 Hibernation

The DK-TM4C129X provides a 32.768-kHz crystal (Y3) as a clock source for the TM4C129X Hibernation module. The board supports hibernation in VDD3ON mode. To measure the current draw during this mode, see [Section 2.1.5](#).

The sleep mode of the 3.3V regulator can be used by moving the 2.2-k $\Omega$  resistor from R2 to R16, which enables the low power mode of the switcher (U7) when TM4C129XNCZAD (U1) goes into hibernation.

## Software Development

---

---

This chapter provides general information on software development as well as instructions for flash memory programming.

### 3.1 Software Description

The software provided with the DK-TM4C129X provides access to all of the peripheral devices supplied in the design. The TivaWare™ for C Series Peripheral Driver Library is used to operate the on-chip peripherals.

The software includes a set of example applications that use the TivaWare™ Peripheral Driver Library. These applications demonstrate the capabilities of the TM4C129XNCZAD microcontroller, as well as provide a starting point for the development of the applications for use on the DK-TM4C129X development board.

### 3.2 Source Code

The complete source code is provided on the DK-TM4C129X USB flash drive. See the [README First](#) document for a detailed description of hardware setup and how to install the source code. The source code and binary files are installed in the TivaWare™ software tree.

### 3.3 Tool Options

The source code installation includes directories containing projects and makefiles for the following tool-chains:

- Keil ARM RealView® Microcontroller Development System
- IAR Embedded Workbench for ARM
- Sourcery Codebench
- Generic GNU C Compiler
- Texas Instruments' Code Composer Studio™ IDE

Download evaluation versions of these tools from the [Tools & Software](#) section of [www.ti.com/tiva](http://www.ti.com/tiva). Due to code size restrictions, the evaluation tools may not build all example programs. A full license is necessary to re-build or debug all examples.

Instructions on installing and using each of the evaluation tools can be found in the Quickstart guides (for example, in the [Keil Quickstart](#) or [IAR Quickstart](#)) in the [References](#) section of this document .

For detailed information on using the tools, see the documentation included in the tool chain installation or visit the website of the tools supplier.

### 3.4 Programming the DK-TM4C129X Board

The DK-TM4C129X software package includes pre-built binaries for each of the example applications. If you installed the TivaWare™ software to the default installation path of `C:\ti\TivaWare_C_Series-x.x`, you can find the example applications in `C:\ti\TivaWare_C_Series-x.x\examples\boards\dk-tm4c129x`. The on-board ICDI is used with the LM Flash Programmer tool to program applications on the DK-TM4C129X board.

Follow these steps to program example applications into the DK-TM4C129X development board using the ICDI:

1. Install the Stellaris ICDI drivers on a Windows PC. Refer to the [README First](#) and the [Stellaris Driver Installation Guide](#).
2. Install LM Flash Programmer on the PC.
3. Connect the USB-A cable plug to an available port on the PC and the Mini-B plug to the board.
4. Verify that the power LEDs (D9, D10 and D1) on the board are lit.
5. Run LM Flash Programmer.
6. In the Configuration tab, use the Quick Set control to select the DK-TM4C129X development board.
7. Move to the Program tab and click the Browse button. Navigate to the example applications directory (the default location is `C:\ti\TivaWare_C_Series-x.x\examples\boards\dk-tm4c129x`).
8. Each example application has its own directory. Navigate to the example directory that you want to load and then into the directory that contains the binary (\*.bin) files. Select the binary file and click Open.
9. Set the “Erase Method” to “Erase Necessary Pages,” check the “Verify After Program” box, and check “Reset MCU After Program”.
10. Click the Program button to start the Erase, Download, and Verify process. The DEBUG ACTIVE LED (D2) on the board turns on at this time.

Program execution starts once the Verify process is complete.

# Component Locations

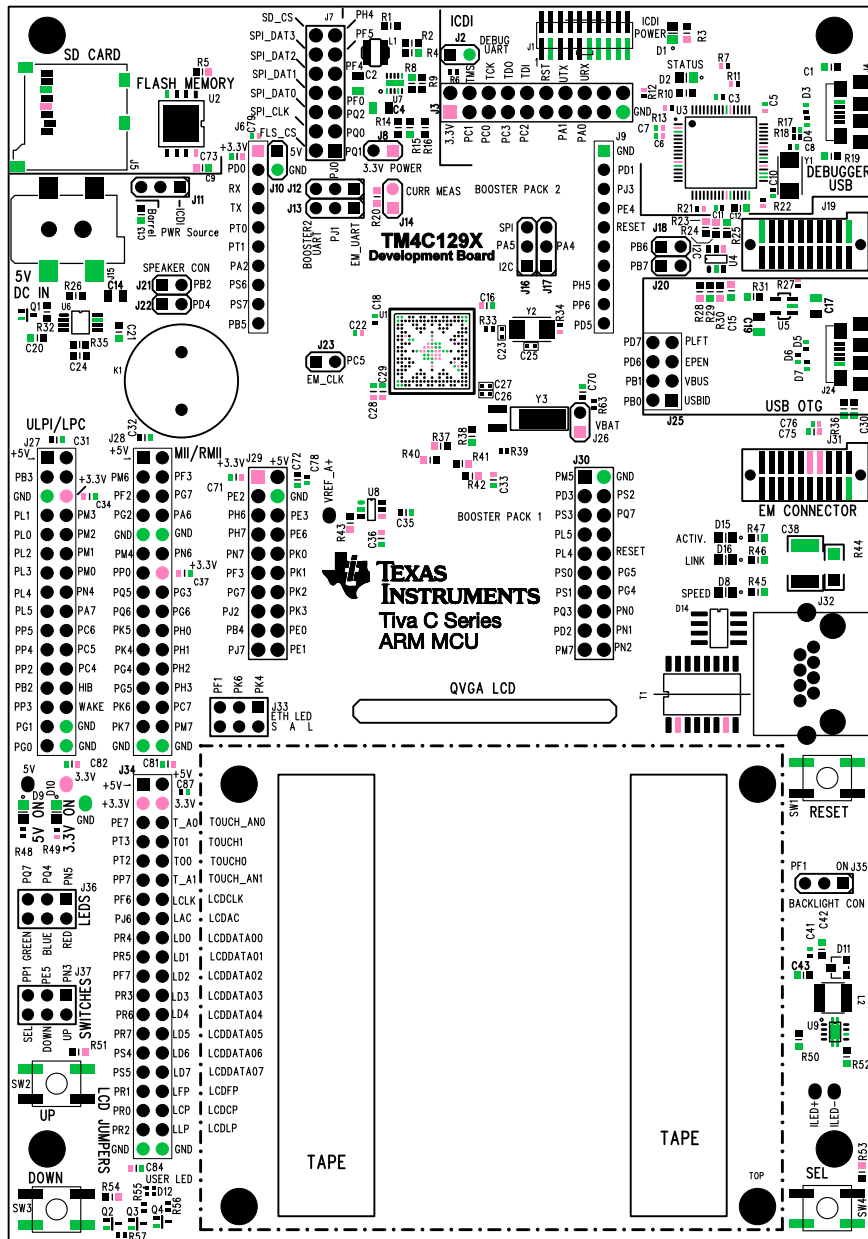

Figure A-1. DK-TM4C129X Component Locations (Top View)

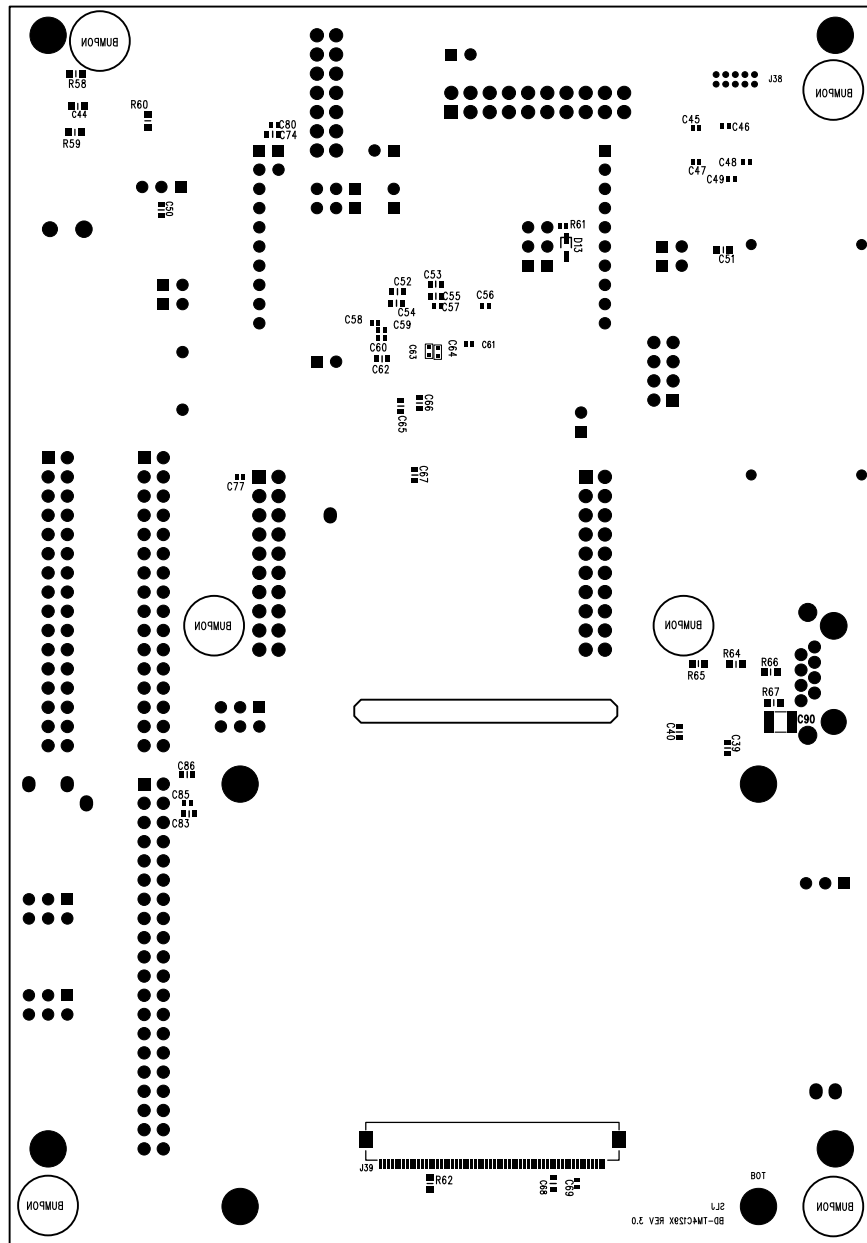

Figure A-2. DK-TM4C129X Component Locations (Bottom View)

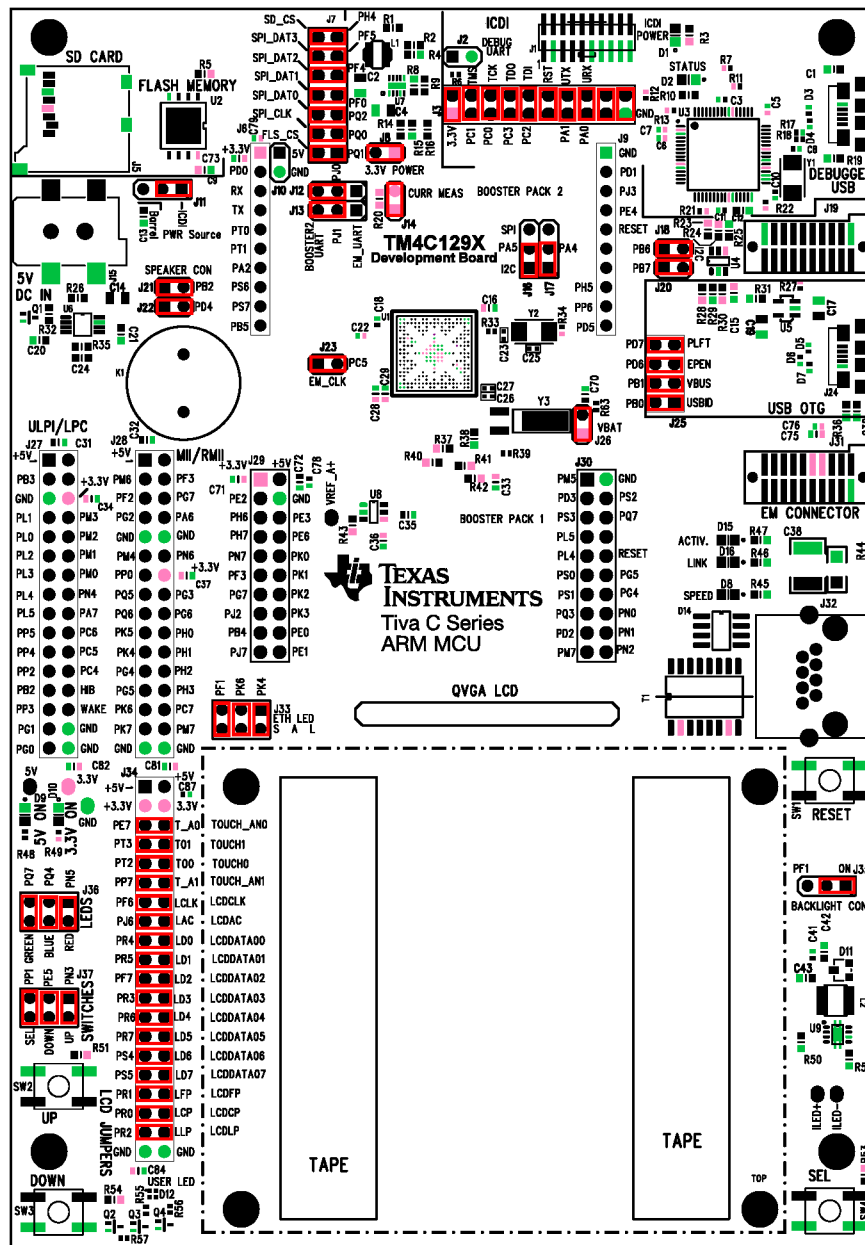

Figure A-3. Jumper and Shunt Locations

## Bill of Materials (BOM)

Item	Ref	Qty	Description	Mfg	Part Number
1	C1, C30	2	Capacitor, 3300pF, 50V, 10%, X7R, 0603	TDK	C1608X7R1H332K
2	C12, C55	2	Capacitor, 2.2uF, 16V, 10%, 0603, X5R	Murata	GRM188R61C225KE15D
3	C13, C16, C28, C29, C31, C32, C33, C34, C35, C36, C37, C39, C40, C42, C50, C52, C53, C54, C62, C65, C66, C67, C68, C70, C71, C72, C73, C74, C75, C81, C82, C83, C84, C86	34	Capacitor, 0.1uF 50V, 20% 0603 X7R	TDK	C1608X7R1H104M
4	C14	1	Capacitor, .047uF 16V 10% X7R 0805	AVX	0805YC473KAT2A
5	C17, C19	2	Capacitor, 4.7uF, 6.3V, 10% 0805, X5R	Taiyo Yuden	JMK212BJ475KG-T
6	C2	1	Capacitor, 22uF 6.3V 20% X5R 0805	TDK	C2012X5R0J226M/1.25
7	C20	1	Capacitor, 0.47uF 10V 10% X5R 0603	TDK	C1608X5R1A474K
8	C21	1	Capacitor, 1.0uF 25V 10% X5R 0603	TDK	C1608X5R1E105K
9	C24	1	Capacitor, 750pF, 50V, 10%, 0603, X7R	Samsung	CL10B751KB8NUNC
10	C26, C27	2	Capacitor, 12pF, 50V 5%, 0402, COG	Murata	GRM1555C1H120JZ01D
11	C3, C6, C22, C45, C46, C56, C60	7	Capacitor, 0.1uF 16V, 10% 0402 X7R	Taiyo Yuden	EMK105B7104KV-F
12	C38	1	Capacitor, 4700pF, 2kV, 10%, X7R, 1812	AVX	1812GC472KAT1A
13	C4	1	Capacitor, 2.2uF 50V 10% X5R 0805	TDK	C2012X5R1H225K
14	C43	1	Capacitor, 4.7uF 10V 10% X5R 0603	TDK	C1608X5R1A475K/0.50
15	C5, C11, C18, C41, C57, C59, C69, C76, C77, C78, C79, C80, C85, C87	14	Capacitor, 1uF , X5R, 10V, 0402	TDK	C1005X5R1A105M050BB
16	C7, C47, C49, C58, C61, C63, C64	7	Capacitor, 0.01uF 25V, 10% 0402 X7R	Taiyo Yuden	TMK105B7103KV-F
17	C8, C10, C23, C25	4	Capacitor, 10pF, 50V, 5%, NPO/COG, 0402	Murata	GRM1555C1H100JZ01D
18	C9, C15, C44, C51	4	Capacitor, 0.1uF 50V, 10% 0603 X7R	Murata	GRM188R71H104KA93D
19	C90	1	Capacitor, 1000pF, 2kV, 20%, X7R, 1812	Kemet	C1210C102MGRACU
20	D1, D2, D10, D15	4	LED, Green 565nm, Clear 0805 SMD	Lite-On	LTST-C171GKT
21	D11	1	Diode, Schottky, 40V, 200mA SOT-23	Fairchild	FYV0704SMTF
22	D12	1	LED, Tri-Color RGB, 0404 SMD Common Anode	Lumex	SML-LX0404SIUPGUSB

Item	Ref	Qty	Description	Mfg	Part Number
23	D13	1	Diode, Schottky, 60V, 15ma, SOD-323	Diodes Inc	SD101AWS-7-F
24	D14	1	Diode, 8 chan, +/-15KV, ESD Protection Array, SO-8	Semtech	SLVU2.8-4.TBT
25	D16	1	LED, Red 630nm, Clear 0805 SMD	Lite-On	LTST-C171EKT
26	D3, D4, D5, D6, D7	5	Diode, 5.6V ESD Suppressor 0402	EPCOS	B72590D0050H160
27	D8, D9	2	LED AMBER CLEAR 0805 SMD	Lite-On	LTST-C170AKT
28	J1	1	Header, 2x10, 2.00mm, SMT, Vertical, Unshrouded	Samtec	ASP17298501
29	J10	1	Header, 1x2, T-Hole Vertical unshrouded stacking	Samtec	ZW-02-15-F-S-265-090
30	J11, J12, J13, J16, J17, J35	6	Header, 1x3, 0.100, T-Hole, Vertical Unshrouded, 0.220 Mate	FCI	68001-103HLF
31	J15	1	Connector, DC Jack SMT 2.5x5.5mm	CUI Inc	PJ-002B-SMT
32	J19, J31	2	Header, 2x10, 0.050, SMT, Vertical, Shrouded, Socket	Samtec	TFM-110-02-S-D-K-A
33	J2, J8, J14, J18, J20, J21, J22, J23, J26	9	Header, 1x2, 0.100, T-Hole, Vertical Unshrouded, 0.220 Mate	3M	961102-6404-AR
34	J24	1	Connector, USB micro AB Receptacle Reversed SMD	Hirose	ZX62R-AB-5P
35	J25	1	Header, 2x4, 0.100, T-Hole, Vertical Unshrouded, 0.230 Mate, gold	FCI	67997-108HLF
36	J27, J28	2	Header, 2x16, 0.100, T-Hole, Vertical Unshrouded, 0.230 Mate, gold	FCI	67997-132HLF
37	J29, J30	2	Header, 2x10, T-Hole Vertical unshrouded stacking	Samtec	ZW-10-15-F-D-265-090
38	J3	1	Header, 2x10, 0.100, T-Hole, Vertical Unshrouded, 0.230 Mate, gold	FCI	67997-220HLF
39	J32	1	Connector, RJ45 NO MAG, shielded THRU HOLE	TE Connectivity	1-406541-5
40	J33, J36, J37	3	Header, 2x3, 0.100, T-Hole, Vertical Unshrouded, 0.230 Mate, gold	FCI	67996-206HLF
41	J34	1	Header, 2x20, 0.100, T-Hole, Vertical Unshrouded, 0.230 Mate, gold	FCI	67997-240HLF
42	J39	1	Connector, FPC 60P, r/a 0.5mm pitch SMT	FCI	10085901-6015ELF
43	J4	1	Connector, rpt, micro usb B SMB	Hirose	ZX62-B-5PA
44	J5	1	Connector, Micro SD card, push-push SMT	3M	2908-05WB-MG
45	J6, J9	2	Header, 1x10, T-Hole Vertical unshrouded stacking	Samtec	ZW-10-15-F-S-265-090
46	J7	1	Header, 2x7, 0.100, T-Hole, Vertical, Unshrouded, 0.230 Mate	FCI	67997-114HLF
47	K1	1	Speaker, 8 Ohm, 15mm diam, 0.5W, 87dB, SM	CUI Inc	CVS-1508
48	L1	1	Inductor 10uH, SMD 2.8x2.8mm, 0.5A, 0.47 Ohm	Würth	744029100



Item	Ref	Qty	Description	Mfg	Part Number
49	L2	1	Inductor 6.8uH, SMD 4mmx4mm, 1.06A, 0.132 Ohm	Taiyo Yuden	NR4018T6R8M
50	Q1, Q2, Q3, Q4	4	NPN SC70 pre-biased	Diodes Inc	DTC114EET1G
51	R1	1	Resistor, 100K OHM 1/10W 5% 0603 Thick	Panasonic	ERJ-3GEYJ104V
52	R14	1	Resistor, 1K Ohm, 1/10W, 5%, SMD, Thick	Panasonic	ERJ-3GEYJ102V
53	R18	1	Resistor, 5.6k ohm, 1/10W, 5%, 0402	Panasonic	ERJ-2GEJ562X
54	R19, R36	2	Resistor, 1M OHM 1/10W 5% 0603 SMD	Panasonic	ERJ-3GEYJ105V
55	R2, R23, R28	3	Resistor, 2.2K OHM 1/10W 5% 0603 SMD	Vishay	CRCW06032K20JNEA
56	R20	1	Resistor, 1 OHM 1/10W 1% 0603, Thick	Panasonic	ERJ-3RQF1R0V
57	R26, R35	2	Resistor, 20K OHM 1/10W 5% 0603 Thick	Yageo	RC0603JR-0720KL
58	R3, R10, R45, R46, R47	5	Resistor, 330 OHM 1/10W 5% 0603 SMD	Panasonic	ERJ-3GEYJ331V
59	R33	1	Resistor, 0 ohm, 1/10W, 5%, 0402	Panasonic	ERJ-2GE0R00X
60	R37, R40, R41, R42	4	Resistor, 49.9 OHM 1/10W 1% 0603 Thick	Panasonic	ERJ-3EKF49R9V
61	R38	1	Resistor, 4.87K Ohm, 1/10W, 1%, SMD, Thick	Panasonic	ERJ-3EKF4871V
62	R44	1	RES 1M OHM 5% 1206 TF	Panasonic	ERJ-8GEYJ105V
63	R48, R49	2	Resistor, 330 ohm, 1/10W, 5%, 0402	Yageo	RC0402FR-07330RL
64	R5, R24, R29, R31, R32, R43, R51, R52, R53, R54, R58, R59, R60, R62	14	Resistor, 10K OHM 1/10W 5% 0603 SMD	Panasonic	ERJ-3GEYJ103V
65	R50	1	Resistor, 13.0 OHM 1/10W 1% 0603 Thick	Panasonic	ERJ-3EKF13R0V
66	R55, R56, R57	3	Resistor, 1.2k ohm, 1/10W, 5%, 0402	Panasonic	ERJ-2GEJ122X
67	R6	1	Resistor, 33 ohm, 1/10W, 5%, 0402	Panasonic	ERJ-2GEJ330X
68	R63	1	Resistor, 51 ohm, 1/10W, 5%, 0402	Panasonic	ERJ-2GEJ510X
69	R64, R65, R66, R67	4	Resistor, 75 Ohm, 1/10W, 1%, SMD, Thick	Panasonic	ERJ-3EKF75R0V
70	R7, R11, R12, R13, R17, R21, R22, R27, R34, R39, R61	11	Resistor, 10k ohm, 1/10W, 5%, 0402 Thick Film	Yageo	RC0402FR-0710KL
71	R8	1	Resistor, 0 OHM 1/10W 0603 SMD	Panasonic	ERJ-3GEY0R00V
72	SW1, SW2, SW3, SW4	4	Switch, Tact 6mm SMT, 160gf	Omron	B3S-1000
73	T1	1	Transformer, ethernet, 1 to 1. SOIC 16	Pulse Electronics	HX1188NL
74	TL1, TL2, TL3, TL4, TL5, TL6	6	Terminal, Test Point Miniature Loop, Red, T-Hole	Keystone	5000
75	U1	1	Stellaris MCU TM4C129XNCZAD 212 BGA, super	Texas Instruments	TM4C129XNCZAD
76	U2	1	Serial Flash 512Mbit 3.3V WSON-8	Macronix	MX66L51235FZ21-10G
77	U3	1	Stellaris TIVA MCU TM4C123GH6PMI	Texas Instruments	TM4C123GH6PMI

Item	Ref	Qty	Description	Mfg	Part Number
78	U4	1	IC, Digital Temperature Sensor -55C to +125C, +/-3C, SOT23-6	Texas Instruments	TMP100NA
79	U5	1	Load Switch, 5.5V, SOT23-5, TPS2051BDBV	Texas Instruments	TPS2051BDBVT
80	U6	1	Op Amp, 0.35W AUDIO MONO AB, 8TSSOP	Texas Instruments	LM4819MM
81	U7	1	Regulator, Step Down 3.3V, 0.5A	Texas Instruments	TPS62177DQC
82	U8	1	Precision 3.0V reference MSOP	Texas Instruments	REF3230AIDBVT
83	U9	1	White LED Driver IC 30V 1.5A SOT23-5	Texas Instruments	TPS61042DRBR
84	Y1	1	Crystal, 16.00MHz 5.0x3.2mm SMT	NDK	NX5032GA-16.000000MHZ
85	Y2	1	Crystal, 25.00MHz 5.0x3.2mm SMT	NDK	NX5032GA-25.000000MHZ
86	Y3	1	Crystal, 32.768KHz Radial Can	Citizen Finetech Miyota	CMR200T-32.768KDZY-UT
87	ZZ	1	BOARD, Snowflake Development Kit Rev 2.0		
<b>PCB Do Not Populate List (Shown for information only)</b>					
88	C48	1	Capacitor, 0.1uF 16V, 10% 0402 X7R	Taiyo Yuden	EMK105B7104KV-F
89	R25, R30	2	Resistor, 10K OHM 1/10W 5% 0603 SMD	Panasonic	ERJ-3GEYJ103V
90	R4, R9, R15, R16	4	Resistor, No Value 1/10W 5% 0603 SMD	Anyone	R0603-OMIT
<b>Final Assembly Bill Of Materials</b>					
91		6	Rubber Feet, Adhesive, Round, 0.312 x 0.200	3M	SJ-61A1
92		58	Jumper, 0.100, Gold, Black, Open	3M	969102-0000-DA
93		1	LCD Module 320 x 240 3.5" TFT, 4-wire touch, White LED	Kentec	K350QVG-V2-F
94		4	VHB Double-Sided Foam Tape, 0.012"x0.5"x1.0"	3M	1/2-5-4926

---

---

## References

---

---

In addition to this document, the following references are included on the Tiva TM4C123GH6PGE Development Kit USB flash drive and are also available for download at [www.ti.com](http://www.ti.com).

- [TivaWare Driver Library](#)
- TivaWare Driver Library User's Guide ([SPMU298](#))
- README First ([SPMU359](#))
- Getting Started Guide ([SPMU361](#))
- Quick Start Guides:
  - Tiva™ C Series Development and Evaluation Kits for Code Composer Studio™ ([SPMU352](#))
  - Tiva™ C Series Development and Evaluation Kits for Keil™ RealView® MDK ([SPMU355](#))
  - Tiva™ C Series Development and Evaluation Kits for IAR Embedded Workbench® ([SPMU354](#))
  - Tiva™ C Series Development and Evaluation Kits for Sourcery CodeBench™ Development Tools ([SPMU356](#))
- Stellaris Driver Installation Guide ([SPMU287](#))

Information on development tool being used:

- RealView MDK website at [www.keil.com/arm/rvmdkkit.asp](http://www.keil.com/arm/rvmdkkit.asp)
- IAR Embedded Workbench website at [www.iar.com](http://www.iar.com)
- Sourcery CodeBench development tools website at [www.codesourcery.com/gnu\\_toolchains/arm](http://www.codesourcery.com/gnu_toolchains/arm)
- Texas Instruments' Code Composer Studio™ IDE website at [www.ti.com/ccs](http://www.ti.com/ccs)

## **Schematics**

---

---

This section contains the schematics for the DK-TM4C129X board.

- Microcontroller, crystals and decoupling capacitors, page 1
- Ethernet, USB, and MII/RMII, ULPI and EPI headers, page 2
- SD card slot, SPI flash, temperature sensor, and speaker with amplifier, page 3
- BoosterPack headers and EM connectors, page 4
- LCD backlight driver, VREF regulator, 3.3V and 5V voltage sources, page 5
- LCD headers, LCD connector, Power LEDs, user LEDs, and user buttons, page 6
- Debug headers, debug jumpers, and ICDI microcontroller, page 7

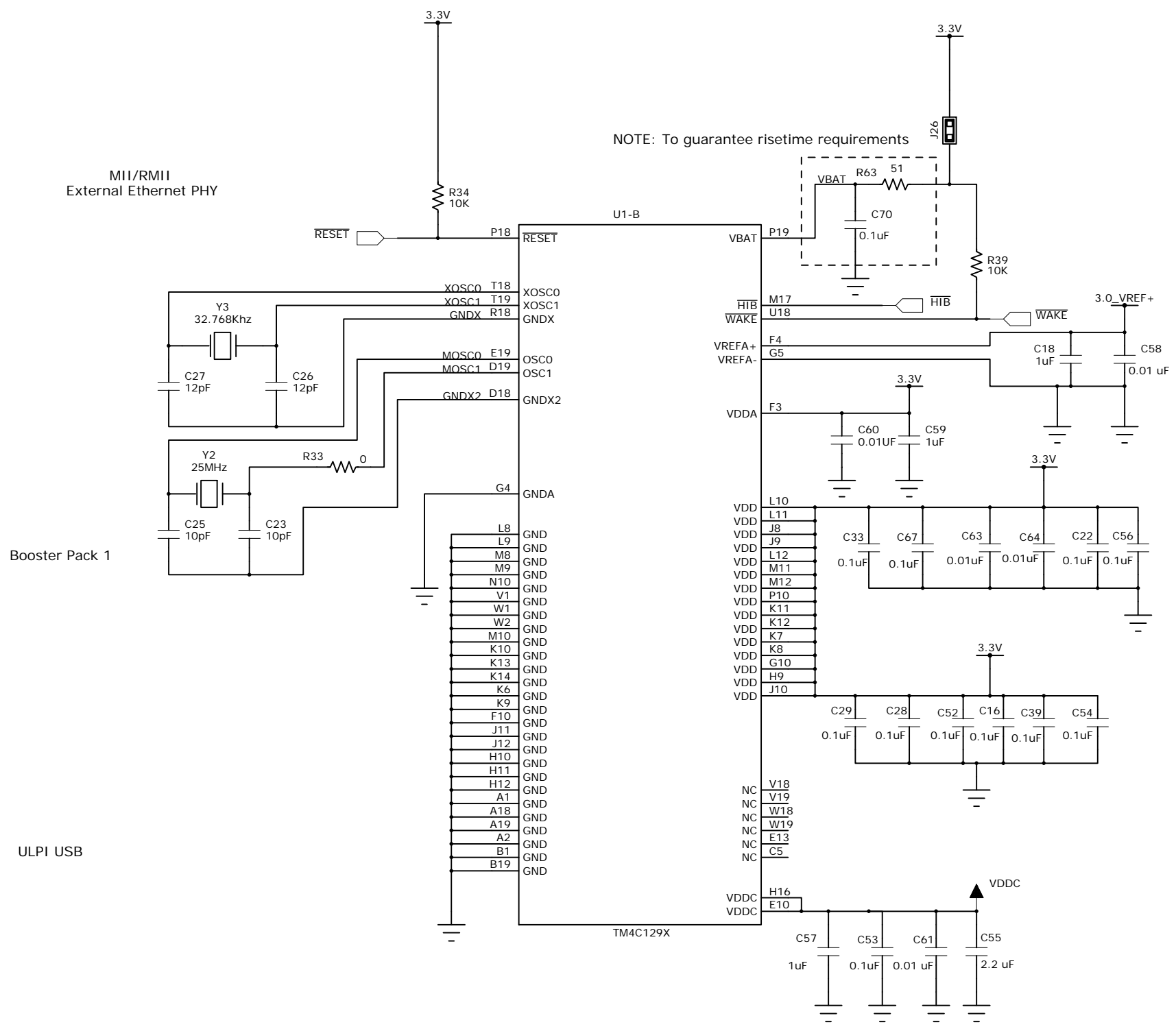
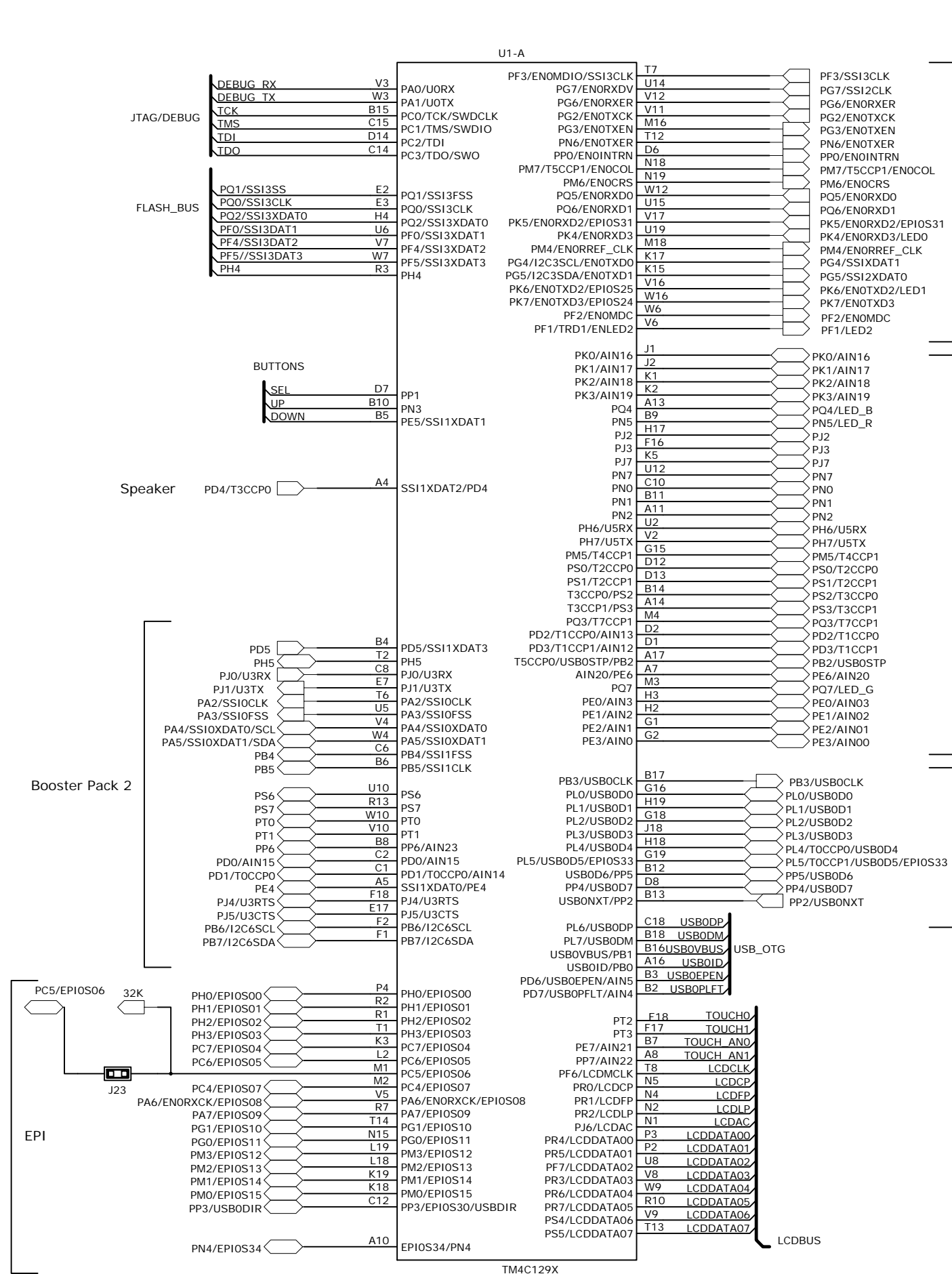

DESIGNER SLJ	REVISION 3.0	DATE 8/6/2013
PROJECT TM4C129X Development Kit		
DESCRIPTION Schematic, DK-TM4C129X C-SERIES		
FILENAME DK-TM4C129X_3.0.sch		



**TEXAS INSTRUMENTS**  
TIVA C SERIES MICROCONTROLLERS

108 WILD BASIN ROAD, SUITE 350  
AUSTIN TX, 78746  
www.ti.com/tiva-c

PART NO. <b>DK-TM4C129X</b>	SHEET <b>1 OF 7</b>
--------------------------------	------------------------

NOTE: Pull up resistors and decoupling cap should be located near U1

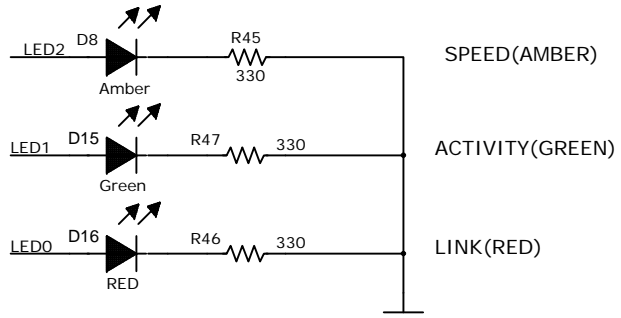
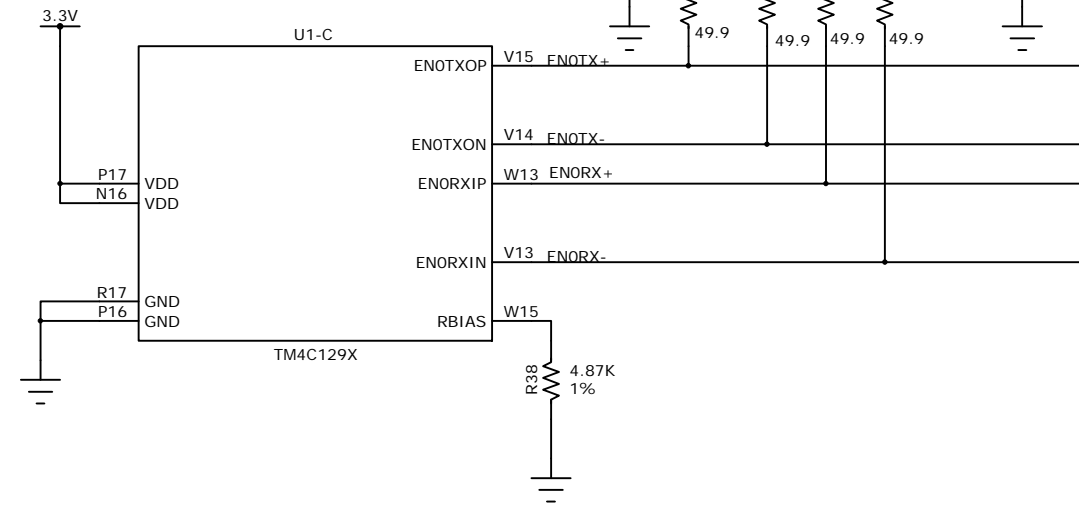
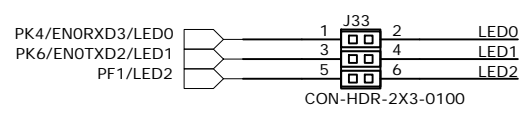

NOTE: C40 and C66 must be located near pin 2 and 7 of T1

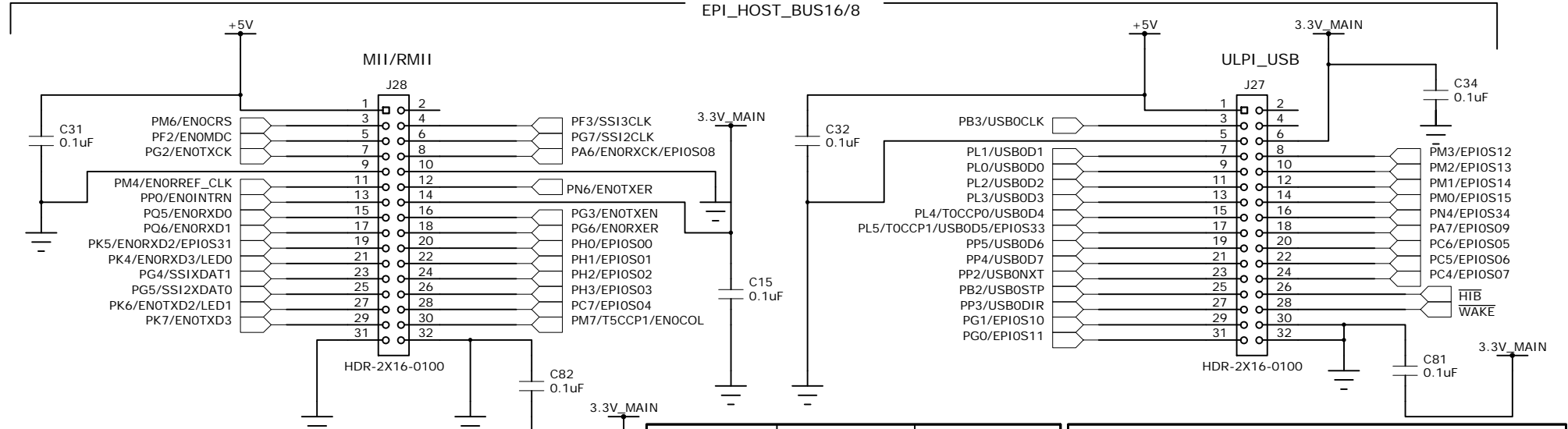
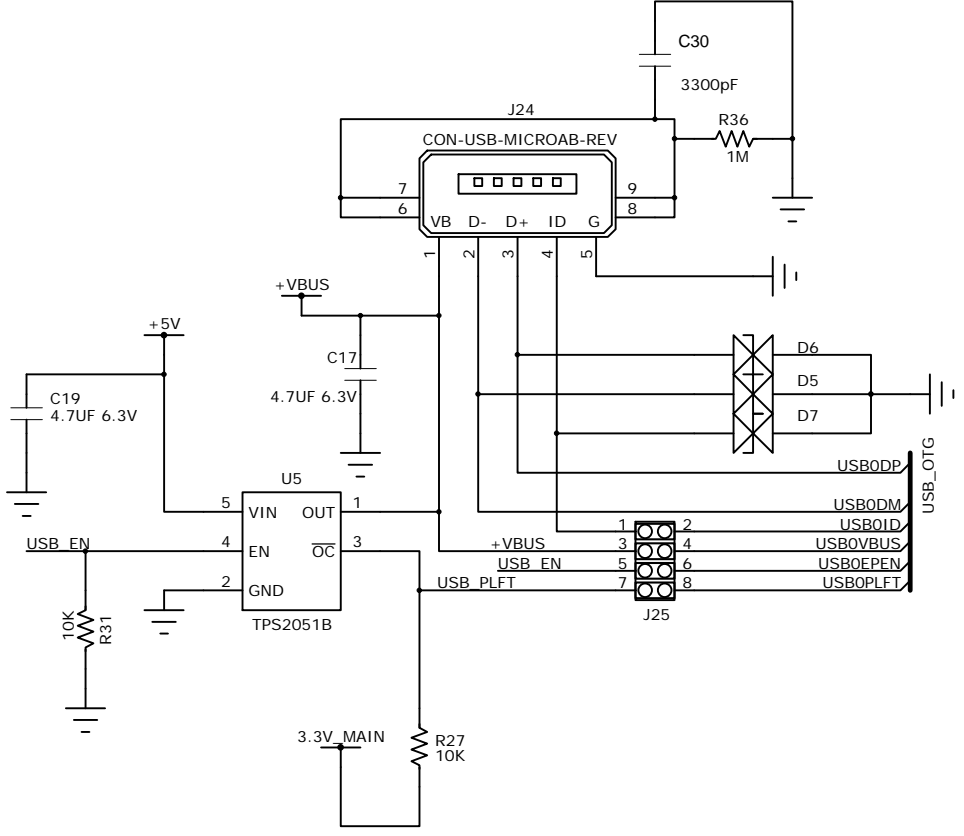
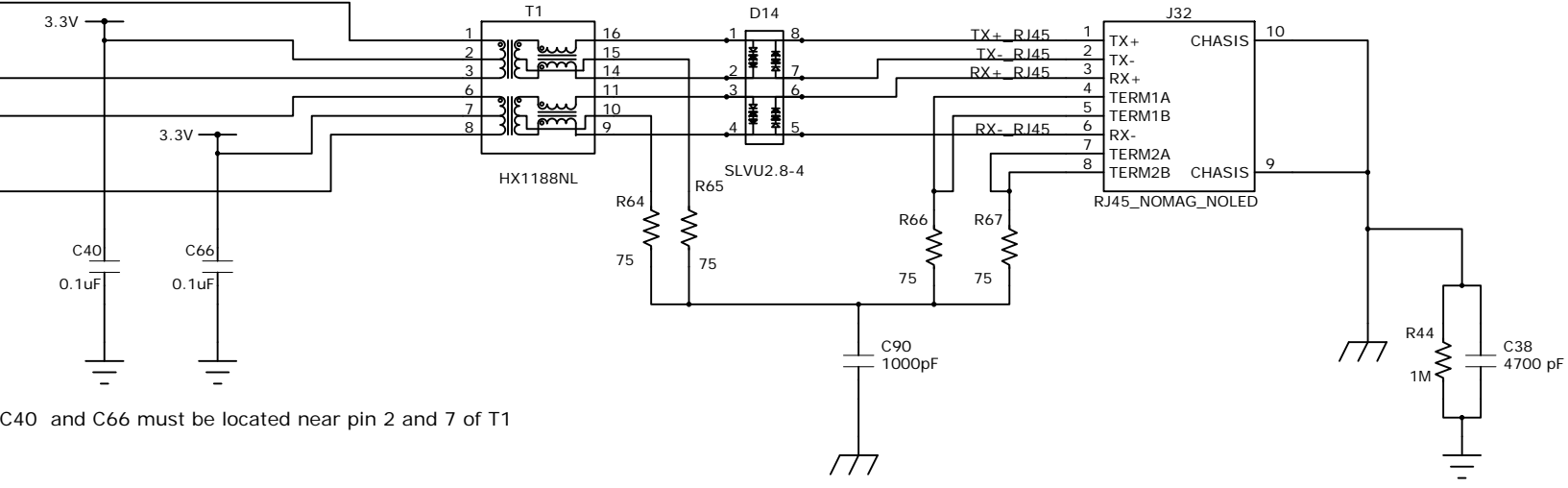

DESIGNER	REVISION	DATE
SLJ	3.0	8/6/2013
PROJECT	TM4C129X Development Kit	
DESCRIPTION	Schematic, DK-TM4C129X C-SERIES	
FILENAME	DK-TM4C129X_3.0.sch	



**TEXAS INSTRUMENTS**  
TIVA C SERIES MICROCONTROLLERS

108 WILD BASIN ROAD, SUITE 350  
AUSTIN TX, 78746  
www.ti.com/tiva-c

PART NO.	SHEET
DK-TM4C129X	2 OF 7

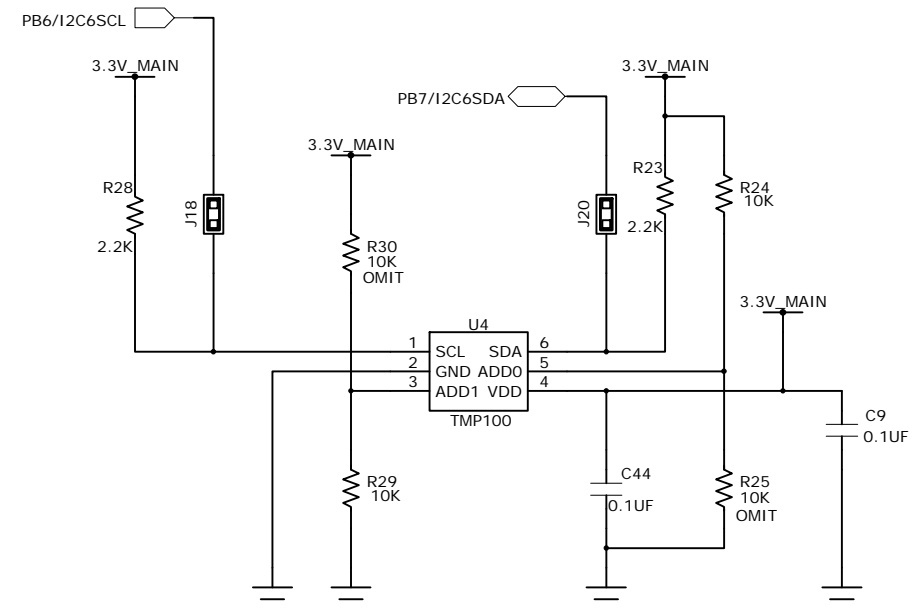
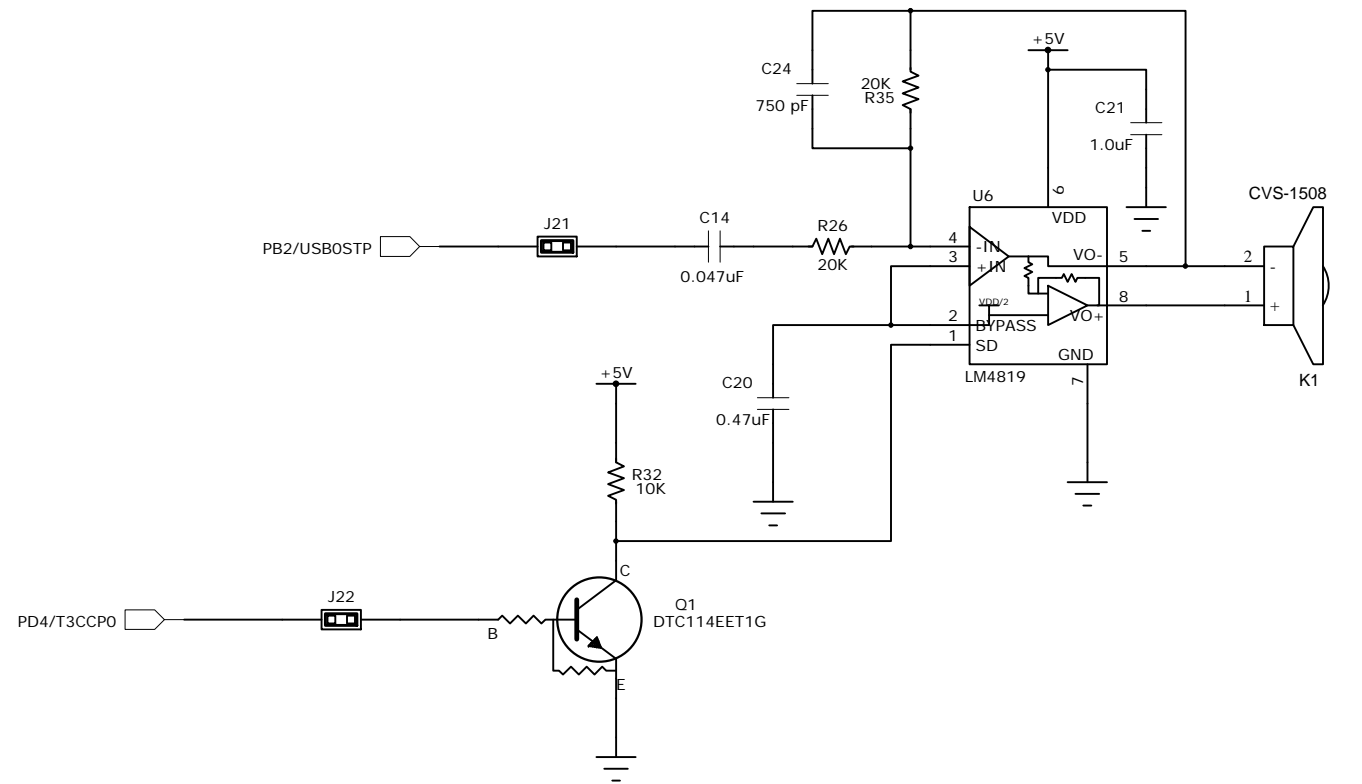
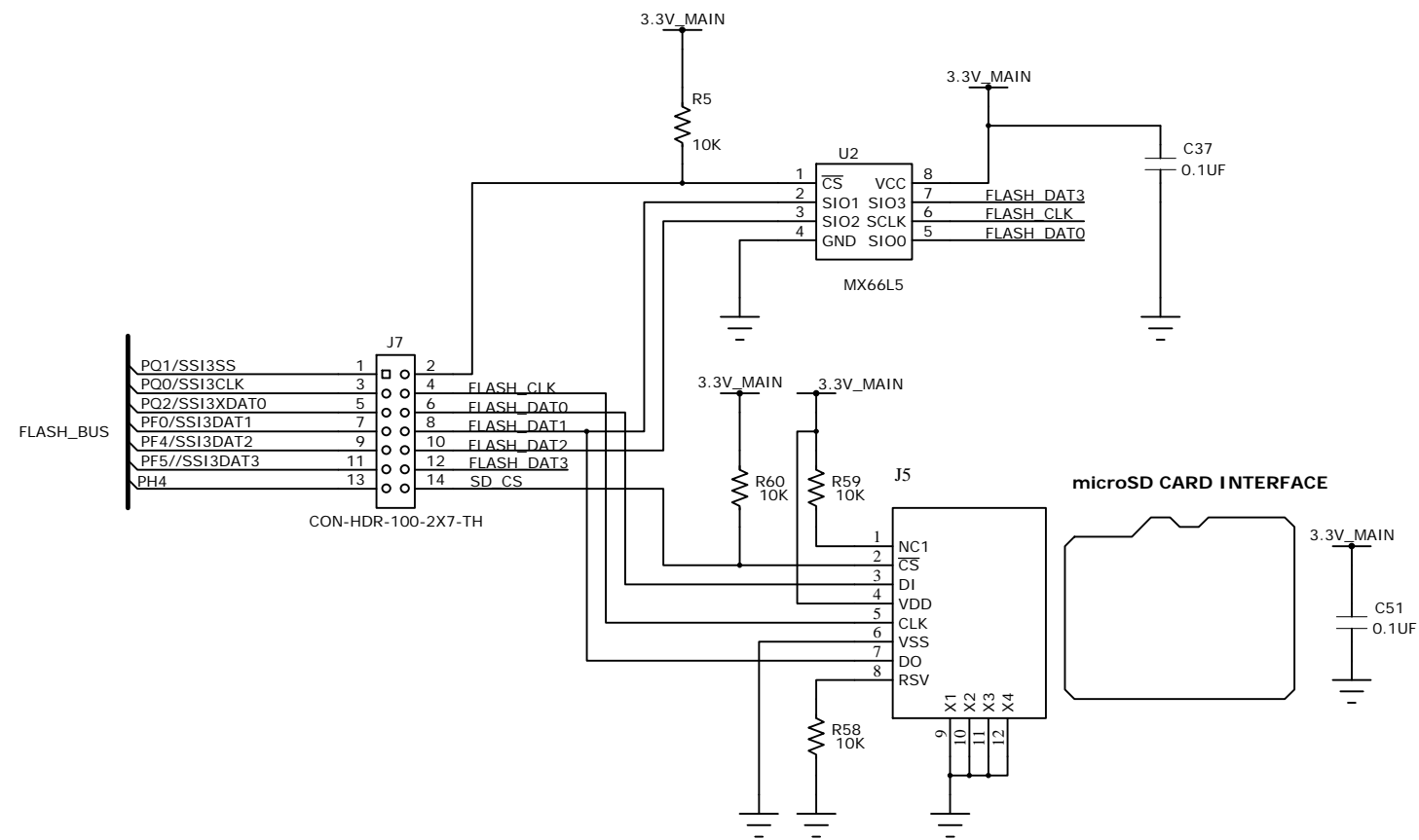

DESIGNER SLJ	REVISION 3.0	DATE 8/6/2013
PROJECT TM4C129X Development Kit		
DESCRIPTION Schematic, DK-TM4C129X C-SERIES		
FILENAME DK-TM4C129X_3.0.sch		

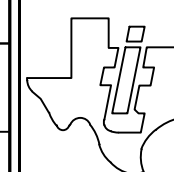

TEXAS INSTRUMENTS  
TIVA C SERIES MICROCONTROLLERS

108 WILD BASIN ROAD, SUITE 350  
AUSTIN TX, 78746

www.ti.com/tiva-c

PART NO. DK-TM4C129X	SHEET 3 OF 7
-------------------------	-----------------

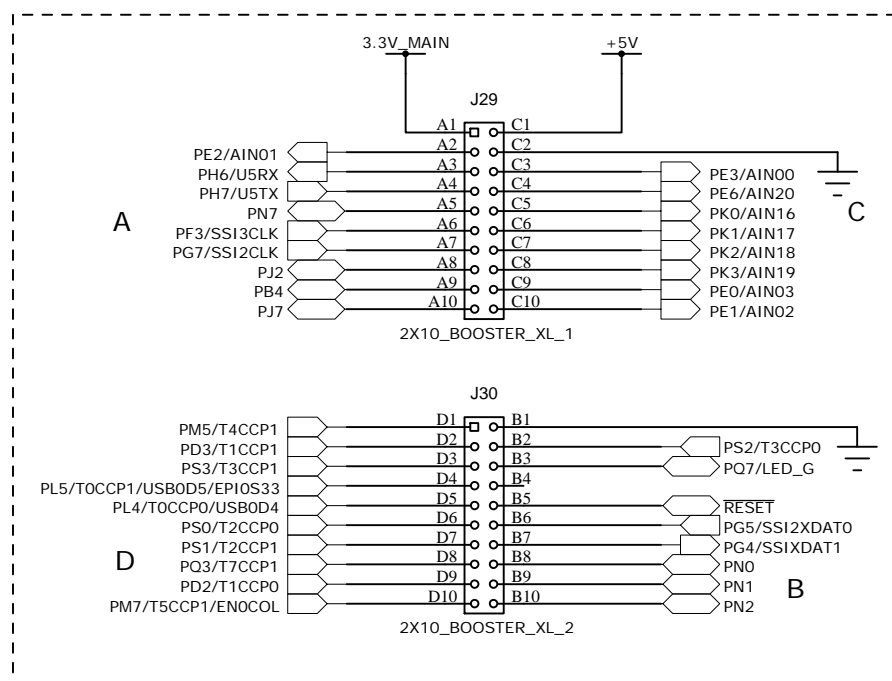

BoosterPack1

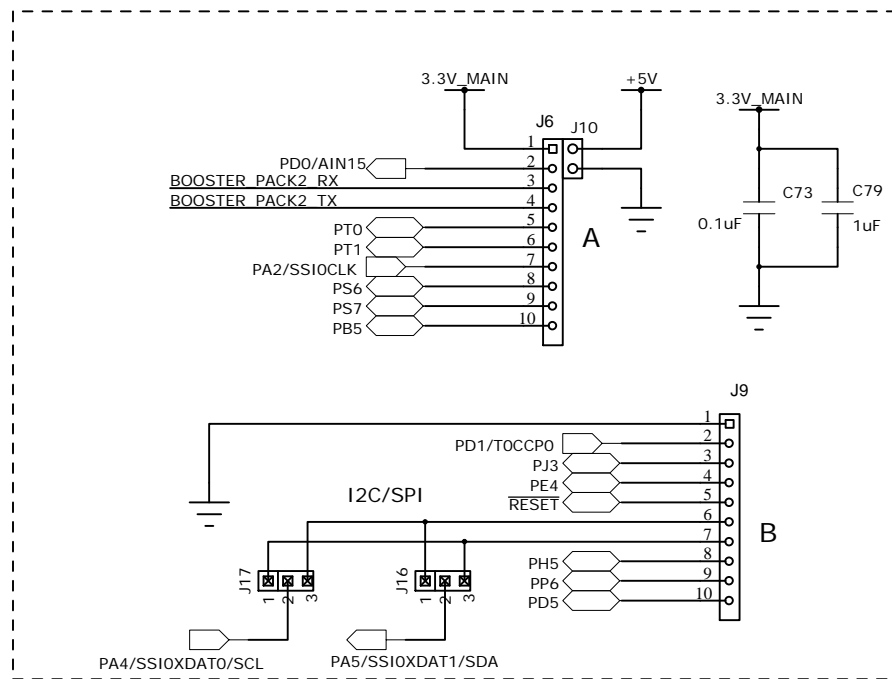
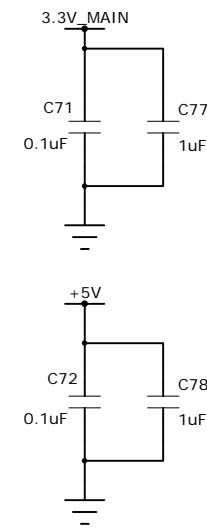

BoosterPack2

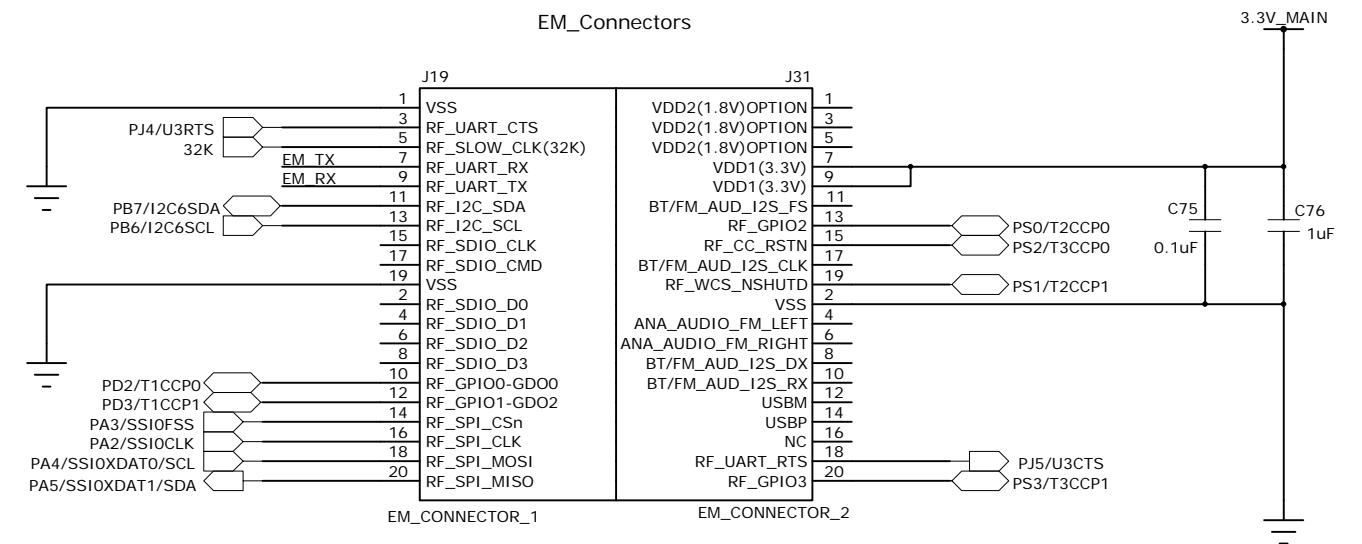
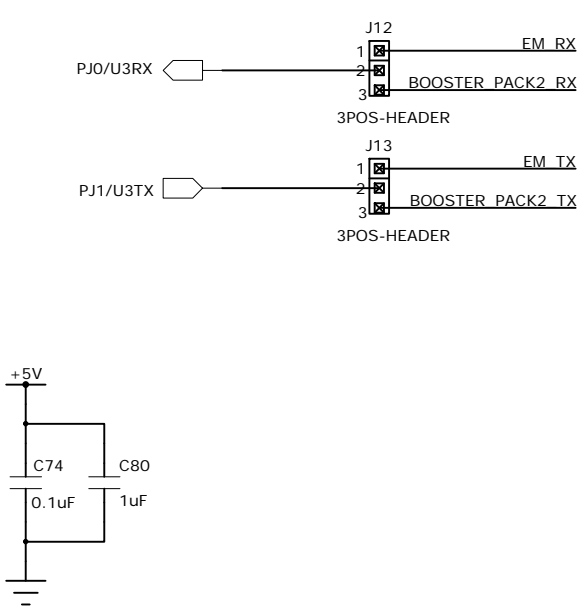

DESIGNER SLJ	REVISION 3.0	DATE 8/6/2013
PROJECT TM4C129X Development Kit		
DESCRIPTION Schematic, DK-TM4C129X C-SERIES		
FILENAME DK-TM4C129X_3.0.sch		



**TEXAS INSTRUMENTS**  
TIVA C SERIES MICROCONTROLLERS

108 WILD BASIN ROAD, SUITE 350  
AUSTIN TX, 78746  
www.ti.com/tiva-c

PART NO. DK-TM4C129X	SHEET 4 OF 7
-------------------------	-----------------



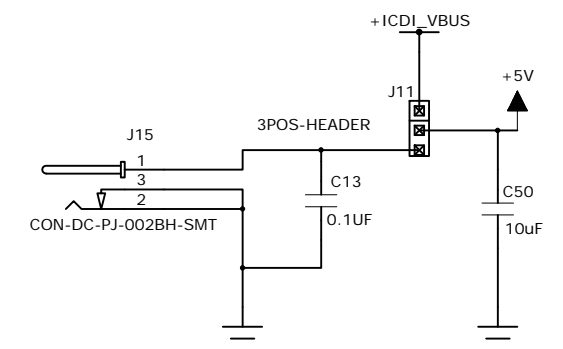
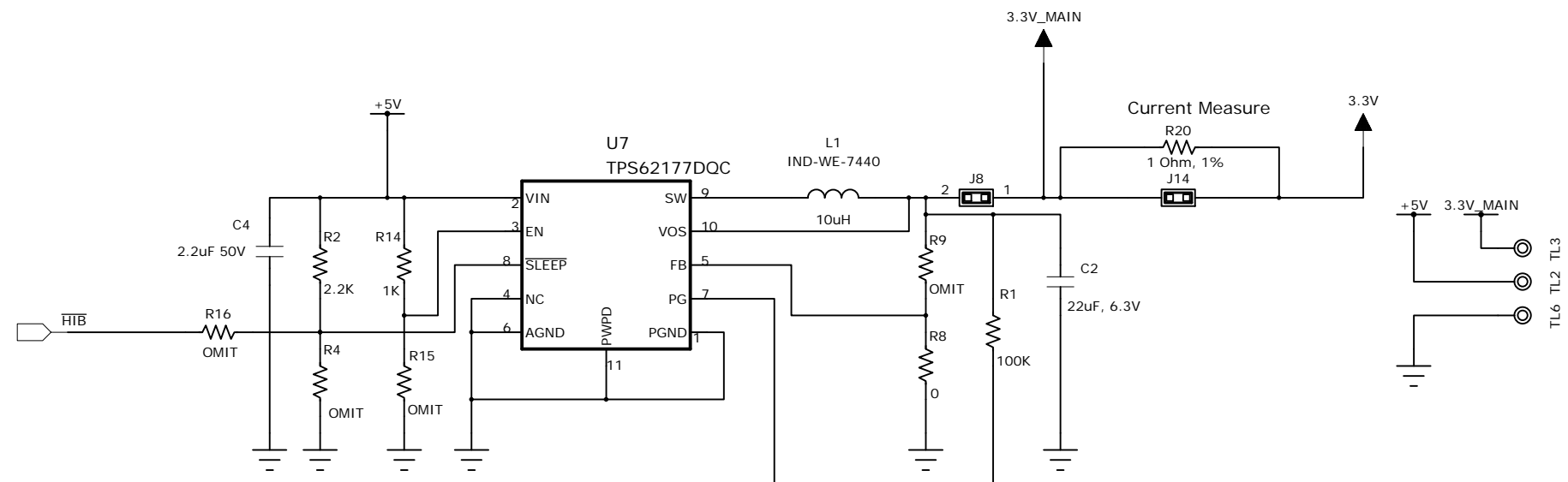
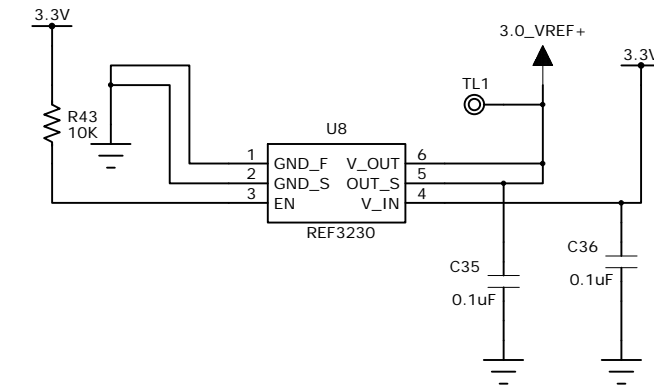
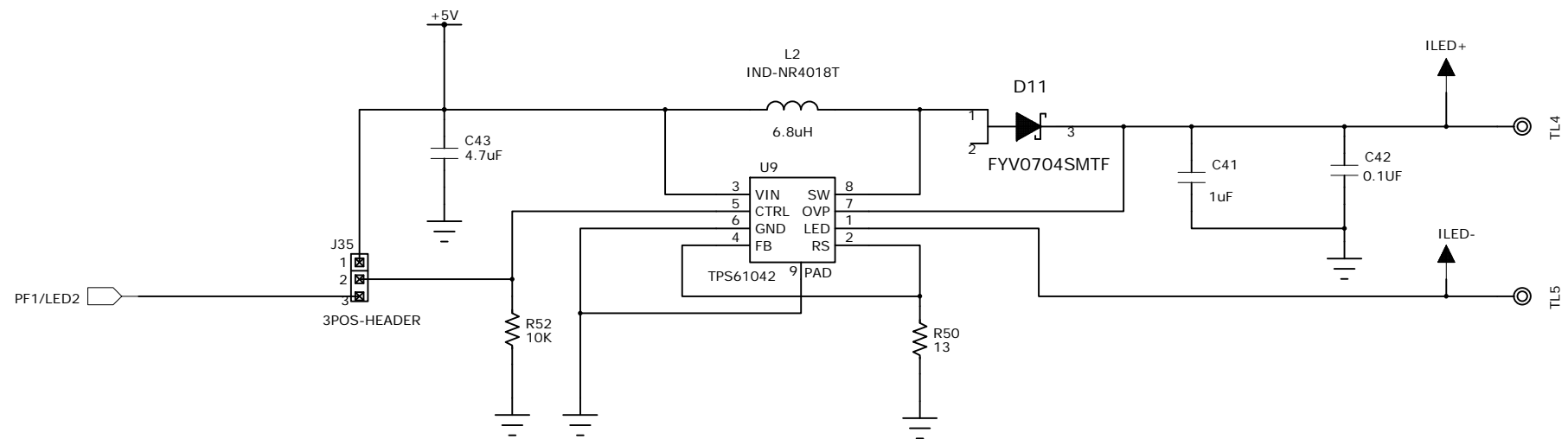

DESIGNER SLJ	REVISION 3.0	DATE 8/6/2013
PROJECT TM4C129X Development Kit		
DESCRIPTION Schematic, DK-TM4C129X C-SERIES		
FILENAME DK-TM4C129X_3.0.sch		

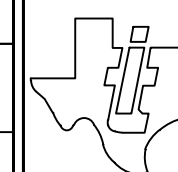

TEXAS INSTRUMENTS  
TIVA C SERIES MICROCONTROLLERS

108 WILD BASIN ROAD, SUITE 350  
AUSTIN TX, 78746

www.ti.com/tiva-c

PART NO. DK-TM4C129X	SHEET 5 OF 7
-------------------------	-----------------

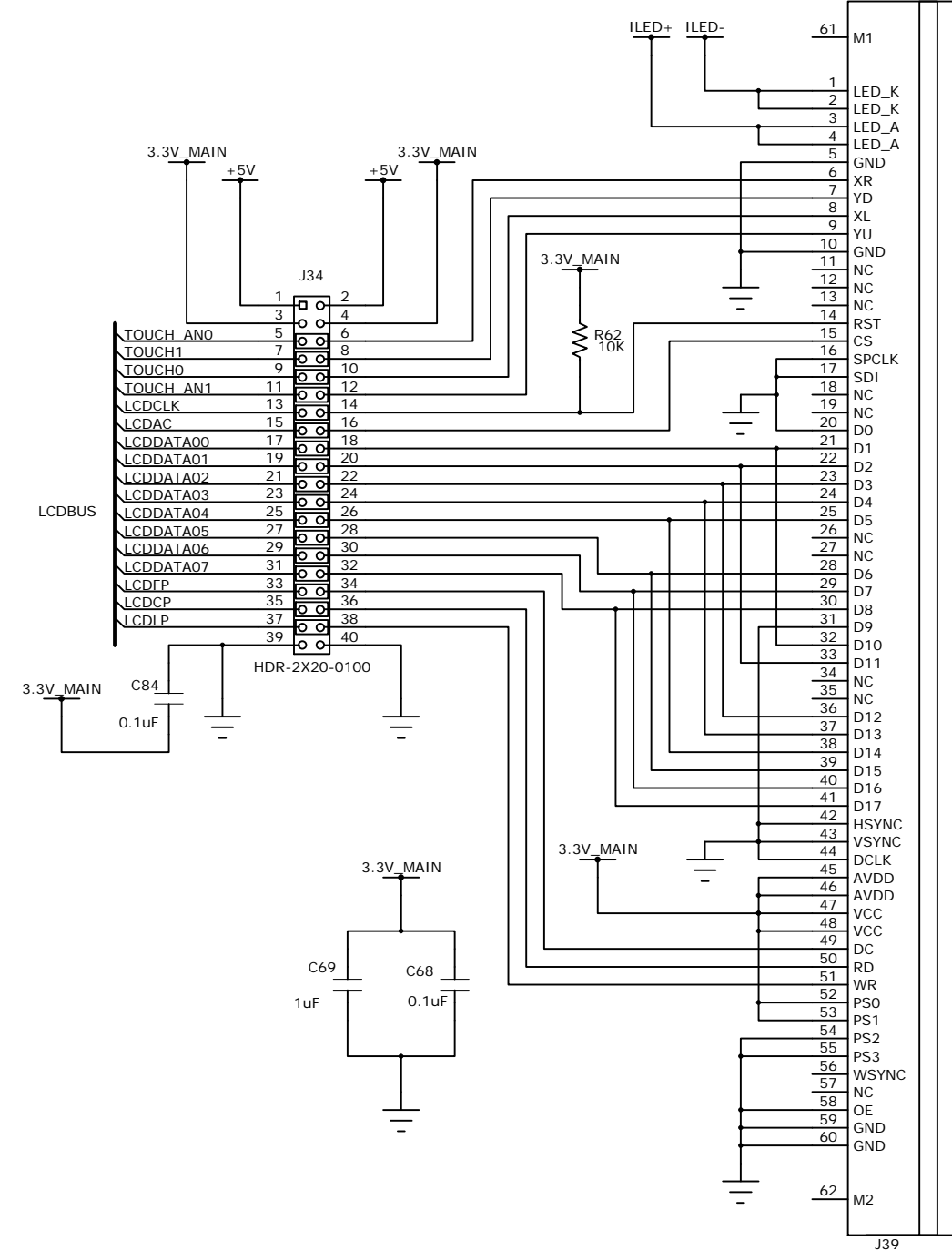
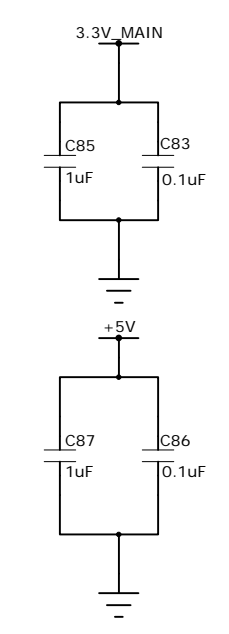
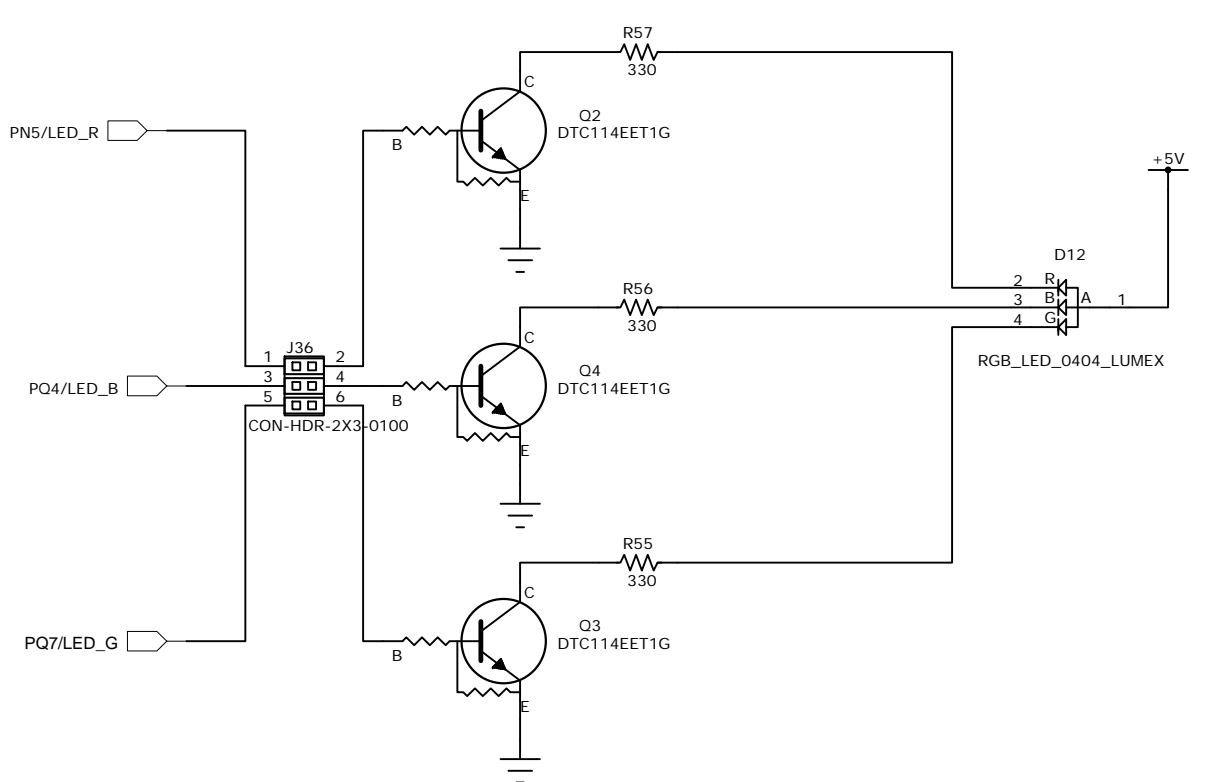
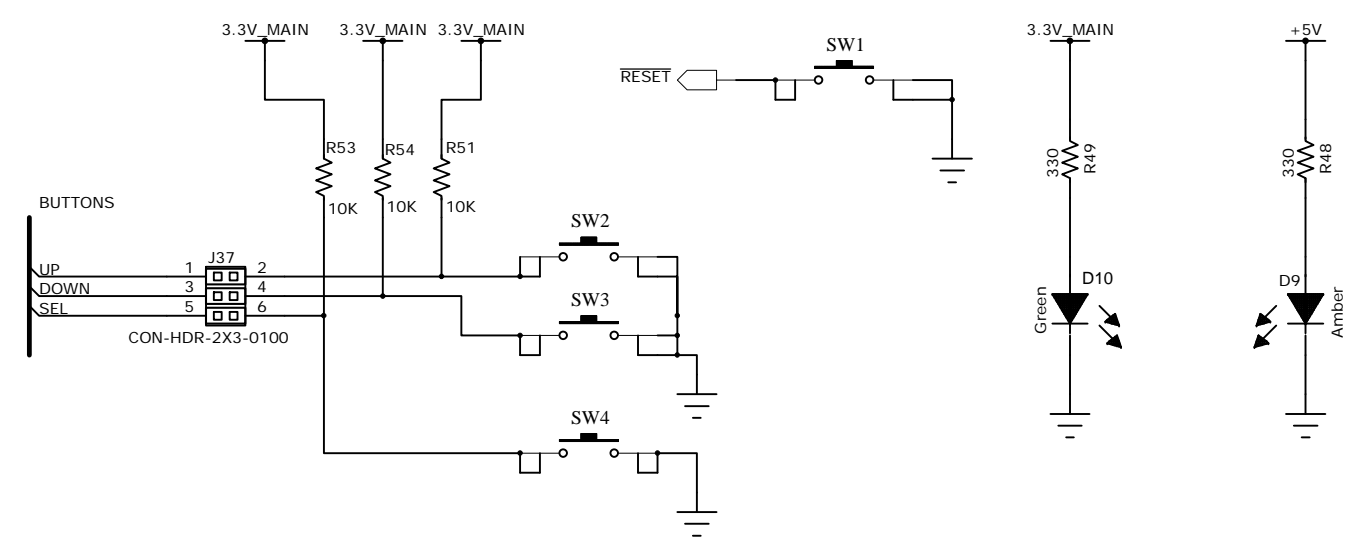

DESIGNER	REVISION	DATE
SLJ	3.0	8/6/2013
PROJECT		
TM4C129X Development Kit		
DESCRIPTION		
Schematic, DK-TM4C129X C-SERIES		
FILENAME	DK-TM4C129X_3.0.sch	

**TEXAS INSTRUMENTS**  
TIVA C SERIES MICROCONTROLLERS

108 WILD BASIN ROAD, SUITE 350  
AUSTIN TX, 78746

[www.ti.com/tiva-c](http://www.ti.com/tiva-c)

PART NO.	DK-TM4C129X	SHEET	6 OF 7
----------	-------------	-------	--------

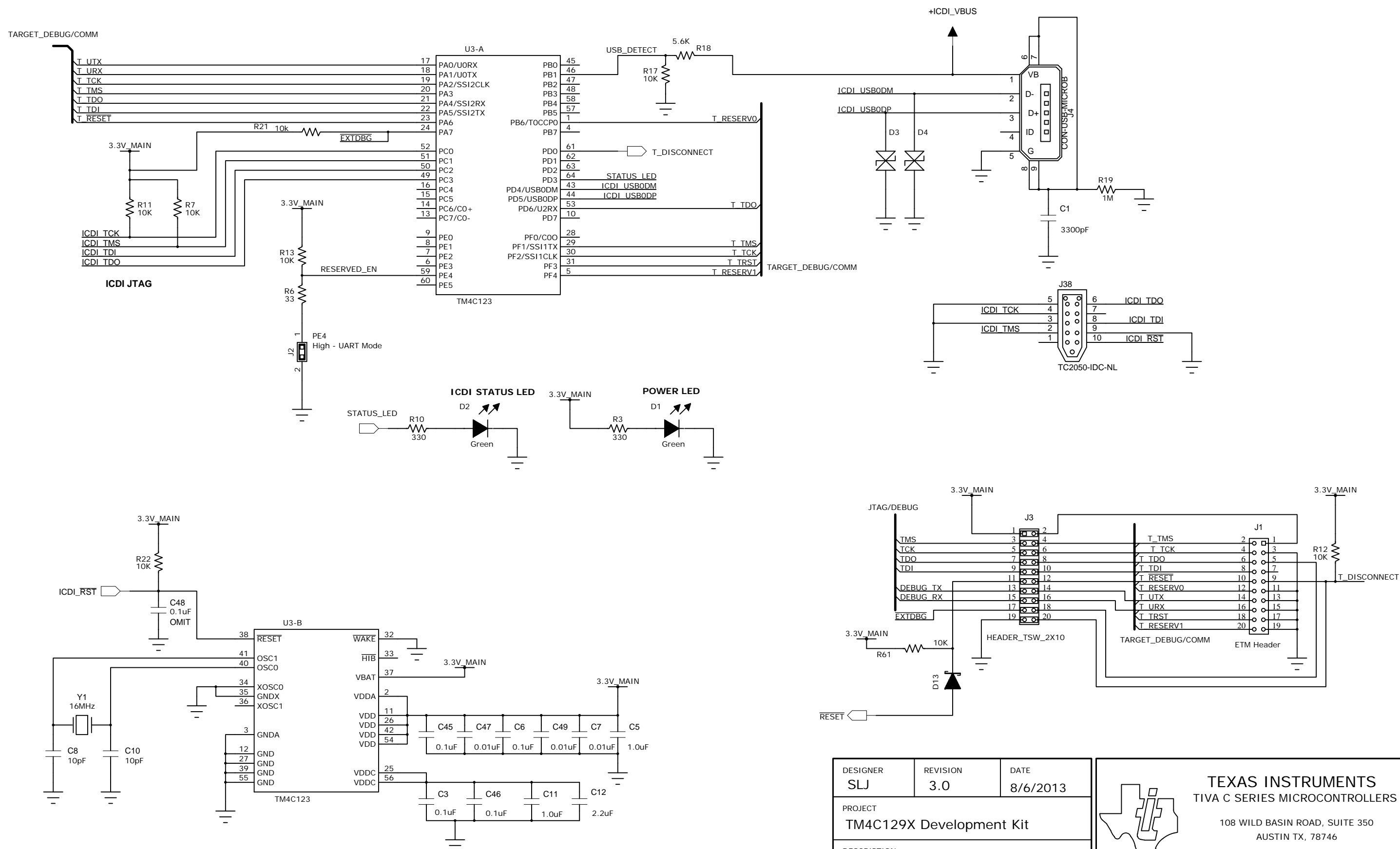

DESIGNER SLJ	REVISION 3.0	DATE 8/6/2013
PROJECT TM4C129X Development Kit		
DESCRIPTION Schematic, DK-TM4C129X C-SERIES		
FILENAME DK-TM4C129X_3.0.sch		



**TEXAS INSTRUMENTS**  
TIVA C SERIES MICROCONTROLLERS

108 WILD BASIN ROAD, SUITE 350  
AUSTIN TX, 78746  
www.ti.com/tiva-c

PART NO. DK-TM4C129X	SHEET 7 OF 7
-------------------------	-----------------

## EVALUATION BOARD/KIT/MODULE (EVM) ADDITIONAL TERMS

Texas Instruments (TI) provides the enclosed Evaluation Board/Kit/Module (EVM) under the following conditions:

The user assumes all responsibility and liability for proper and safe handling of the goods. Further, the user indemnifies TI from all claims arising from the handling or use of the goods.

Should this evaluation board/kit not meet the specifications indicated in the User's Guide, the board/kit may be returned within 30 days from the date of delivery for a full refund. THE FOREGOING LIMITED WARRANTY IS THE EXCLUSIVE WARRANTY MADE BY SELLER TO BUYER AND IS IN LIEU OF ALL OTHER WARRANTIES, EXPRESSED, IMPLIED, OR STATUTORY, INCLUDING ANY WARRANTY OF MERCHANTABILITY OR FITNESS FOR ANY PARTICULAR PURPOSE. EXCEPT TO THE EXTENT OF THE INDEMNITY SET FORTH ABOVE, NEITHER PARTY SHALL BE LIABLE TO THE OTHER FOR ANY INDIRECT, SPECIAL, INCIDENTAL, OR CONSEQUENTIAL DAMAGES.

Please read the User's Guide and, specifically, the Warnings and Restrictions notice in the User's Guide prior to handling the product. This notice contains important safety information about temperatures and voltages. For additional information on TI's environmental and/or safety programs, please visit [www.ti.com/esh](http://www.ti.com/esh) or contact TI.

No license is granted under any patent right or other intellectual property right of TI covering or relating to any machine, process, or combination in which such TI products or services might be or are used. TI currently deals with a variety of customers for products, and therefore our arrangement with the user is not exclusive. TI assumes no liability for applications assistance, customer product design, software performance, or infringement of patents or services described herein.

## REGULATORY COMPLIANCE INFORMATION

As noted in the EVM User's Guide and/or EVM itself, this EVM and/or accompanying hardware may or may not be subject to the Federal Communications Commission (FCC) and Industry Canada (IC) rules.

For EVMs **not** subject to the above rules, this evaluation board/kit/module is intended for use for ENGINEERING DEVELOPMENT, DEMONSTRATION OR EVALUATION PURPOSES ONLY and is not considered by TI to be a finished end product fit for general consumer use. It generates, uses, and can radiate radio frequency energy and has not been tested for compliance with the limits of computing devices pursuant to part 15 of FCC or ICES-003 rules, which are designed to provide reasonable protection against radio frequency interference. Operation of the equipment may cause interference with radio communications, in which case the user at his own expense will be required to take whatever measures may be required to correct this interference.

### General Statement for EVMs including a radio

*User Power/Frequency Use Obligations:* This radio is intended for development/professional use only in legally allocated frequency and power limits. Any use of radio frequencies and/or power availability of this EVM and its development application(s) must comply with local laws governing radio spectrum allocation and power limits for this evaluation module. It is the user's sole responsibility to only operate this radio in legally acceptable frequency space and within legally mandated power limitations. Any exceptions to this are strictly prohibited and unauthorized by Texas Instruments unless user has obtained appropriate experimental/development licenses from local regulatory authorities, which is responsibility of user including its acceptable authorization.

### For EVMs annotated as FCC – FEDERAL COMMUNICATIONS COMMISSION Part 15 Compliant

#### Caution

This device complies with part 15 of the FCC Rules. Operation is subject to the following two conditions: (1) This device may not cause harmful interference, and (2) this device must accept any interference received, including interference that may cause undesired operation.

Changes or modifications not expressly approved by the party responsible for compliance could void the user's authority to operate the equipment.

### FCC Interference Statement for Class A EVM devices

This equipment has been tested and found to comply with the limits for a Class A digital device, pursuant to part 15 of the FCC Rules. These limits are designed to provide reasonable protection against harmful interference when the equipment is operated in a commercial environment. This equipment generates, uses, and can radiate radio frequency energy and, if not installed and used in accordance with the instruction manual, may cause harmful interference to radio communications. Operation of this equipment in a residential area is likely to cause harmful interference in which case the user will be required to correct the interference at his own expense.

### **FCC Interference Statement for Class B EVM devices**

This equipment has been tested and found to comply with the limits for a Class B digital device, pursuant to part 15 of the FCC Rules. These limits are designed to provide reasonable protection against harmful interference in a residential installation. This equipment generates, uses and can radiate radio frequency energy and, if not installed and used in accordance with the instructions, may cause harmful interference to radio communications. However, there is no guarantee that interference will not occur in a particular installation. If this equipment does cause harmful interference to radio or television reception, which can be determined by turning the equipment off and on, the user is encouraged to try to correct the interference by one or more of the following measures:

- Reorient or relocate the receiving antenna.
- Increase the separation between the equipment and receiver.
- Connect the equipment into an outlet on a circuit different from that to which the receiver is connected.
- Consult the dealer or an experienced radio/TV technician for help.

### **For EVMs annotated as IC – INDUSTRY CANADA Compliant**

This Class A or B digital apparatus complies with Canadian ICES-003.

Changes or modifications not expressly approved by the party responsible for compliance could void the user's authority to operate the equipment.

### **Concerning EVMs including radio transmitters**

This device complies with Industry Canada licence-exempt RSS standard(s). Operation is subject to the following two conditions: (1) this device may not cause interference, and (2) this device must accept any interference, including interference that may cause undesired operation of the device.

### **Concerning EVMs including detachable antennas**

Under Industry Canada regulations, this radio transmitter may only operate using an antenna of a type and maximum (or lesser) gain approved for the transmitter by Industry Canada. To reduce potential radio interference to other users, the antenna type and its gain should be so chosen that the equivalent isotropically radiated power (e.i.r.p.) is not more than that necessary for successful communication.

This radio transmitter has been approved by Industry Canada to operate with the antenna types listed in the user guide with the maximum permissible gain and required antenna impedance for each antenna type indicated. Antenna types not included in this list, having a gain greater than the maximum gain indicated for that type, are strictly prohibited for use with this device.

Cet appareil numérique de la classe A ou B est conforme à la norme NMB-003 du Canada.

Les changements ou les modifications pas expressément approuvés par la partie responsable de la conformité ont pu vider l'autorité de l'utilisateur pour actionner l'équipement.

### **Concernant les EVMs avec appareils radio**

Le présent appareil est conforme aux CNR d'Industrie Canada applicables aux appareils radio exempts de licence. L'exploitation est autorisée aux deux conditions suivantes : (1) l'appareil ne doit pas produire de brouillage, et (2) l'utilisateur de l'appareil doit accepter tout brouillage radioélectrique subi, même si le brouillage est susceptible d'en compromettre le fonctionnement.

### **Concernant les EVMs avec antennes détachables**

Conformément à la réglementation d'Industrie Canada, le présent émetteur radio peut fonctionner avec une antenne d'un type et d'un gain maximal (ou inférieur) approuvé pour l'émetteur par Industrie Canada. Dans le but de réduire les risques de brouillage radioélectrique à l'intention des autres utilisateurs, il faut choisir le type d'antenne et son gain de sorte que la puissance isotrope rayonnée équivalente (p.i.r.e.) ne dépasse pas l'intensité nécessaire à l'établissement d'une communication satisfaisante.

Le présent émetteur radio a été approuvé par Industrie Canada pour fonctionner avec les types d'antenne énumérés dans le manuel d'usage et ayant un gain admissible maximal et l'impédance requise pour chaque type d'antenne. Les types d'antenne non inclus dans cette liste, ou dont le gain est supérieur au gain maximal indiqué, sont strictement interdits pour l'exploitation de l'émetteur.

## **【Important Notice for Users of EVMs for RF Products in Japan】**

**This development kit is NOT certified as Confirming to Technical Regulations of Radio Law of Japan**

If you use this product in Japan, you are required by Radio Law of Japan to follow the instructions below with respect to this product:

1. Use this product in a shielded room or any other test facility as defined in the notification #173 issued by Ministry of Internal Affairs and Communications on March 28, 2006, based on Sub-section 1.1 of Article 6 of the Ministry's Rule for Enforcement of Radio Law of Japan,
2. Use this product only after you obtained the license of Test Radio Station as provided in Radio Law of Japan with respect to this product, or
3. Use of this product only after you obtained the Technical Regulations Conformity Certification as provided in Radio Law of Japan with respect to this product. Also, please do not transfer this product, unless you give the same notice above to the transferee. Please note that if you could not follow the instructions above, you will be subject to penalties of Radio Law of Japan.

**Texas Instruments Japan Limited**  
**(address) 24-1, Nishi-Shinjuku 6 chome, Shinjuku-ku, Tokyo, Japan**

<http://www.tij.co.jp>

### **【無線電波を送信する製品の開発キットをお使いになる際の注意事項】**

本開発キットは技術基準適合証明を受けておりません。

本製品のご使用に際しては、電波法遵守のため、以下のいずれかの措置を取っていただく必要がありますのでご注意ください。

1. 電波法施行規則第6条第1項第1号に基づく平成18年3月28日総務省告示第173号で定められた電波暗室等の試験設備でご使用いただく。
2. 実験局の免許を取得後ご使用いただく。
3. 技術基準適合証明を取得後ご使用いただく。

なお、本製品は、上記の「ご使用にあたっての注意」を譲渡先、移転先に通知しない限り、譲渡、移転できないものとします。

上記を遵守頂けない場合は、電波法の罰則が適用される可能性があることをご留意ください。

日本テキサス・インスツルメンツ株式会社

東京都新宿区西新宿 6 丁目 2 4 番 1 号

西新宿三井ビル

<http://www.tij.co.jp>

## **EVALUATION BOARD/KIT/MODULE (EVM) WARNINGS, RESTRICTIONS AND DISCLAIMERS**

**For Feasibility Evaluation Only, in Laboratory/Development Environments.** Unless otherwise indicated, this EVM is not a finished electrical equipment and not intended for consumer use. It is intended solely for use for preliminary feasibility evaluation in laboratory/development environments by technically qualified electronics experts who are familiar with the dangers and application risks associated with handling electrical mechanical components, systems and subsystems. It should not be used as all or part of a finished end product.

Your Sole Responsibility and Risk. You acknowledge, represent and agree that:

1. You have unique knowledge concerning Federal, State and local regulatory requirements (including but not limited to Food and Drug Administration regulations, if applicable) which relate to your products and which relate to your use (and/or that of your employees, affiliates, contractors or designees) of the EVM for evaluation, testing and other purposes.
2. You have full and exclusive responsibility to assure the safety and compliance of your products with all such laws and other applicable regulatory requirements, and also to assure the safety of any activities to be conducted by you and/or your employees, affiliates, contractors or designees, using the EVM. Further, you are responsible to assure that any interfaces (electronic and/or mechanical) between the EVM and any human body are designed with suitable isolation and means to safely limit accessible leakage currents to minimize the risk of electrical shock hazard.
3. Since the EVM is not a completed product, it may not meet all applicable regulatory and safety compliance standards (such as UL, CSA, VDE, CE, RoHS and WEEE) which may normally be associated with similar items. You assume full responsibility to determine and/or assure compliance with any such standards and related certifications as may be applicable. You will employ reasonable safeguards to ensure that your use of the EVM will not result in any property damage, injury or death, even if the EVM should fail to perform as described or expected.
4. You will take care of proper disposal and recycling of the EVM's electronic components and packing materials.

**Certain Instructions.** It is important to operate this EVM within TI's recommended specifications and environmental considerations per the user guidelines. Exceeding the specified EVM ratings (including but not limited to input and output voltage, current, power, and environmental ranges) may cause property damage, personal injury or death. If there are questions concerning these ratings please contact a TI field representative prior to connecting interface electronics including input power and intended loads. Any loads applied outside of the specified output range may result in unintended and/or inaccurate operation and/or possible permanent damage to the EVM and/or interface electronics. Please consult the EVM User's Guide prior to connecting any load to the EVM output. If there is uncertainty as to the load specification, please contact a TI field representative. During normal operation, some circuit components may have case temperatures greater than 60°C as long as the input and output are maintained at a normal ambient operating temperature. These components include but are not limited to linear regulators, switching transistors, pass transistors, and current sense resistors which can be identified using the EVM schematic located in the EVM User's Guide. When placing measurement probes near these devices during normal operation, please be aware that these devices may be very warm to the touch. As with all electronic evaluation tools, only qualified personnel knowledgeable in electronic measurement and diagnostics normally found in development environments should use these EVMs.

**Agreement to Defend, Indemnify and Hold Harmless.** You agree to defend, indemnify and hold TI, its licensors and their representatives harmless from and against any and all claims, damages, losses, expenses, costs and liabilities (collectively, "Claims") arising out of or in connection with any use of the EVM that is not in accordance with the terms of the agreement. This obligation shall apply whether Claims arise under law of tort or contract or any other legal theory, and even if the EVM fails to perform as described or expected.

**Safety-Critical or Life-Critical Applications.** If you intend to evaluate the components for possible use in safety critical applications (such as life support) where a failure of the TI product would reasonably be expected to cause severe personal injury or death, such as devices which are classified as FDA Class III or similar classification, then you must specifically notify TI of such intent and enter into a separate Assurance and Indemnity Agreement.

Mailing Address: Texas Instruments, Post Office Box 655303, Dallas, Texas 75265  
Copyright © 2013, Texas Instruments Incorporated

## IMPORTANT NOTICE

Texas Instruments Incorporated and its subsidiaries (TI) reserve the right to make corrections, enhancements, improvements and other changes to its semiconductor products and services per JESD46, latest issue, and to discontinue any product or service per JESD48, latest issue. Buyers should obtain the latest relevant information before placing orders and should verify that such information is current and complete. All semiconductor products (also referred to herein as "components") are sold subject to TI's terms and conditions of sale supplied at the time of order acknowledgment.

TI warrants performance of its components to the specifications applicable at the time of sale, in accordance with the warranty in TI's terms and conditions of sale of semiconductor products. Testing and other quality control techniques are used to the extent TI deems necessary to support this warranty. Except where mandated by applicable law, testing of all parameters of each component is not necessarily performed.

TI assumes no liability for applications assistance or the design of Buyers' products. Buyers are responsible for their products and applications using TI components. To minimize the risks associated with Buyers' products and applications, Buyers should provide adequate design and operating safeguards.

TI does not warrant or represent that any license, either express or implied, is granted under any patent right, copyright, mask work right, or other intellectual property right relating to any combination, machine, or process in which TI components or services are used. Information published by TI regarding third-party products or services does not constitute a license to use such products or services or a warranty or endorsement thereof. Use of such information may require a license from a third party under the patents or other intellectual property of the third party, or a license from TI under the patents or other intellectual property of TI.

Reproduction of significant portions of TI information in TI data books or data sheets is permissible only if reproduction is without alteration and is accompanied by all associated warranties, conditions, limitations, and notices. TI is not responsible or liable for such altered documentation. Information of third parties may be subject to additional restrictions.

Resale of TI components or services with statements different from or beyond the parameters stated by TI for that component or service voids all express and any implied warranties for the associated TI component or service and is an unfair and deceptive business practice. TI is not responsible or liable for any such statements.

Buyer acknowledges and agrees that it is solely responsible for compliance with all legal, regulatory and safety-related requirements concerning its products, and any use of TI components in its applications, notwithstanding any applications-related information or support that may be provided by TI. Buyer represents and agrees that it has all the necessary expertise to create and implement safeguards which anticipate dangerous consequences of failures, monitor failures and their consequences, lessen the likelihood of failures that might cause harm and take appropriate remedial actions. Buyer will fully indemnify TI and its representatives against any damages arising out of the use of any TI components in safety-critical applications.

In some cases, TI components may be promoted specifically to facilitate safety-related applications. With such components, TI's goal is to help enable customers to design and create their own end-product solutions that meet applicable functional safety standards and requirements. Nonetheless, such components are subject to these terms.

No TI components are authorized for use in FDA Class III (or similar life-critical medical equipment) unless authorized officers of the parties have executed a special agreement specifically governing such use.

Only those TI components which TI has specifically designated as military grade or "enhanced plastic" are designed and intended for use in military/aerospace applications or environments. Buyer acknowledges and agrees that any military or aerospace use of TI components which have **not** been so designated is solely at the Buyer's risk, and that Buyer is solely responsible for compliance with all legal and regulatory requirements in connection with such use.

TI has specifically designated certain components as meeting ISO/TS16949 requirements, mainly for automotive use. In any case of use of non-designated products, TI will not be responsible for any failure to meet ISO/TS16949.

### Products

Audio	<a href="http://www.ti.com/audio">www.ti.com/audio</a>
Amplifiers	<a href="http://amplifier.ti.com">amplifier.ti.com</a>
Data Converters	<a href="http://dataconverter.ti.com">dataconverter.ti.com</a>
DLP® Products	<a href="http://www.dlp.com">www.dlp.com</a>
DSP	<a href="http://dsp.ti.com">dsp.ti.com</a>
Clocks and Timers	<a href="http://www.ti.com/clocks">www.ti.com/clocks</a>
Interface	<a href="http://interface.ti.com">interface.ti.com</a>
Logic	<a href="http://logic.ti.com">logic.ti.com</a>
Power Mgmt	<a href="http://power.ti.com">power.ti.com</a>
Microcontrollers	<a href="http://microcontroller.ti.com">microcontroller.ti.com</a>
RFID	<a href="http://www.ti-rfid.com">www.ti-rfid.com</a>
OMAP Applications Processors	<a href="http://www.ti.com/omap">www.ti.com/omap</a>
Wireless Connectivity	<a href="http://www.ti.com/wirelessconnectivity">www.ti.com/wirelessconnectivity</a>

### Applications

Automotive and Transportation	<a href="http://www.ti.com/automotive">www.ti.com/automotive</a>
Communications and Telecom	<a href="http://www.ti.com/communications">www.ti.com/communications</a>
Computers and Peripherals	<a href="http://www.ti.com/computers">www.ti.com/computers</a>
Consumer Electronics	<a href="http://www.ti.com/consumer-apps">www.ti.com/consumer-apps</a>
Energy and Lighting	<a href="http://www.ti.com/energy">www.ti.com/energy</a>
Industrial	<a href="http://www.ti.com/industrial">www.ti.com/industrial</a>
Medical	<a href="http://www.ti.com/medical">www.ti.com/medical</a>
Security	<a href="http://www.ti.com/security">www.ti.com/security</a>
Space, Avionics and Defense	<a href="http://www.ti.com/space-avionics-defense">www.ti.com/space-avionics-defense</a>
Video and Imaging	<a href="http://www.ti.com/video">www.ti.com/video</a>

### TI E2E Community

[e2e.ti.com](http://e2e.ti.com)