

**ADVANCED 2-HEAD
PLAY-BACK AND RECORD AMPLIFIER FOR VCR**

PLAY-BACK MODE

- LOW NOISE AND WIDE BAND AMPLIFIERS FOR 2 HEADS
- AUTOMATIC OFFSET CANCELLATION BETWEEN THE 2 SELECTED HEADS
- ONE PLAY-BACK OUTPUT WITHOUT AGC
- ONE PLAY-BACK OUTPUT INCLUDING AGC
- RECORD AMPLIFIER INHIBITION AND RECORD OUTPUT GROUNDED
- OUTPUT FOR TRACKING VIDEO INFORMATION (TRIV) WITH ADJUSTABLE GAIN

RECORD MODE

- ONE INTEGRATED I/I CONVERTER WITH ACCURATE CONTROL OF TRANSCONDUCTANCE
- AUTOMATIC PLAY-BACK/RECORD SWITCHING BY SCANNING OF RECORD SUPPLY
- PLAY-BACK LOOP INHIBITION

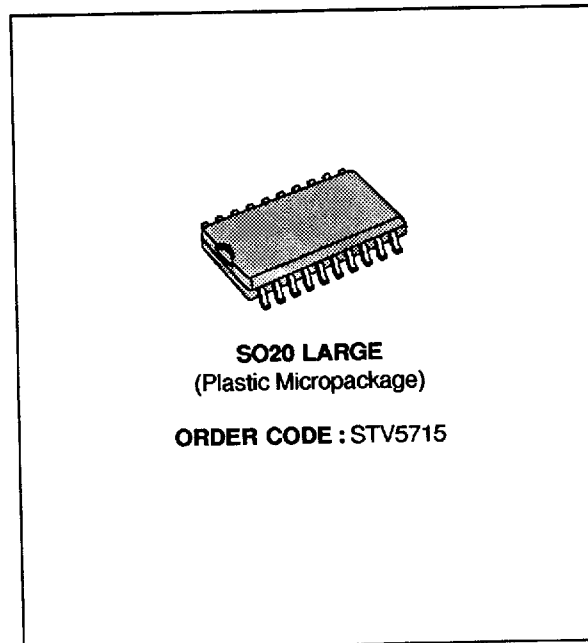

PIN DESCRIPTION

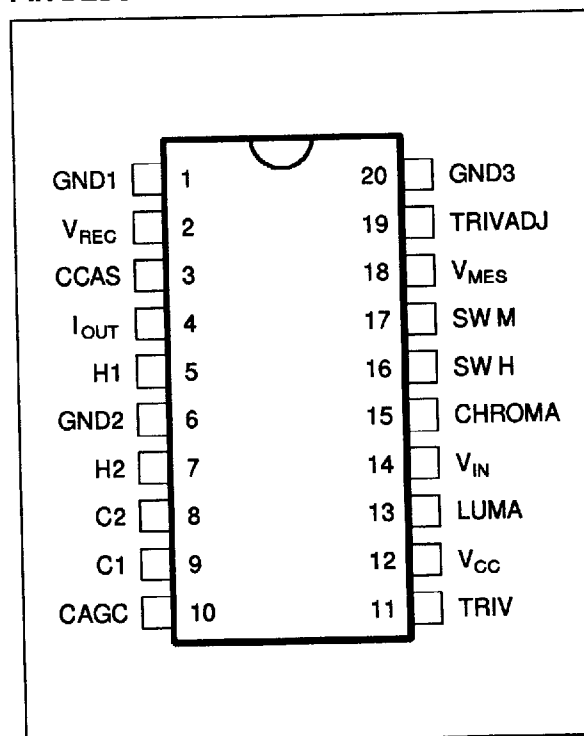

DESCRIPTION

The STV5715 is an advanced two head record and play-back amplifier for VCR.

BLOCK DIAGRAM

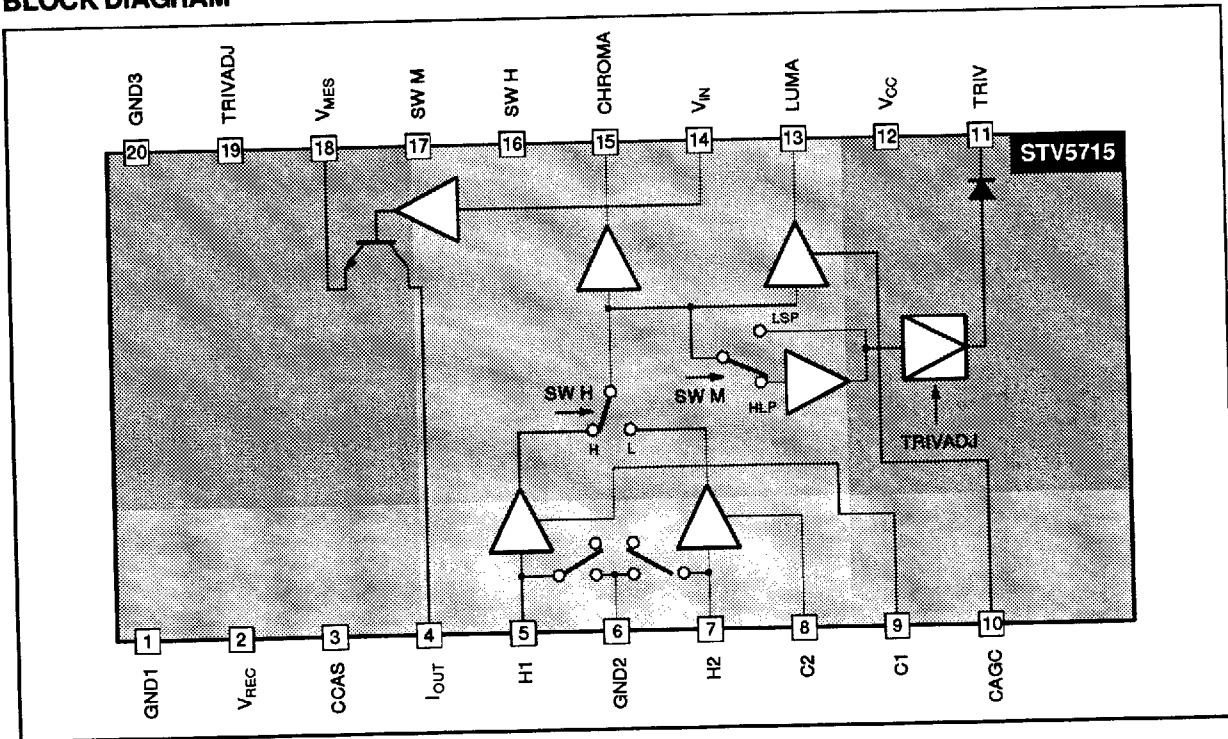

FUNCTIONAL DESCRIPTION

STV5715 is intended for 2 heads VCR applications. It includes all the electrical functions necessary to achieve play-back and record processing for VHS and S-VHS applications (10MHz bandwidth). High performance technology allows very low noise levels (current and voltage), which are frequency independent in all the frequency range. In play-back mode a special feature suppresses the DC offset when switching the two channels. Optimized play-back output stage gives to the STV5715 large capability to drive directly a coaxial cable in order to reduce number of external components. Two play-back outputs are available : one, dedicated to Chroma processing, is a 60dB voltage amplifier output, the other, dedicated to Luma processing, is phase opposite signal with a constant AC output level of 200mV_{PP} at 3.8MHz signal. A tracking information for video signal (TRIV) is Luma amplitude proportional and allows automatic

phase correction. The transfer function has a gain of 2.5dB higher when a LP channel is selected. Adding to this, a gain control bloc allows to modify the gain (± 6 dB) of the TRIV function for all the channels by applying a bias on pin TRIVADJ.

An automatic scanning of record supply voltage permits STV5715 automatically switching either in play-back or in record mode. The switching threshold voltage is fixed to a value which forbids high current peaking through the heads.

During play-back mode, record output is grounded via an internal transistor and during record mode preamplifiers are turned off.

There is one output current for two recording heads, the DC current and the AC characteristics can be very precisely controlled with accurate external resistors. If recommended resistances are used, a $\pm 3\%$ transconductance accuracy is guaranteed.

STV5715 is fully protected against ESD.

ABSOLUTE MAXIMUM RATINGS

Symbol	Parameter	Value	Unit
V _{CC}	Power Supply Voltage	6	V
V _{REC}	Power Supply Voltage Record	15	V
T _J	Junction Temperature	+150	°C
T _{oper}	Operating Temperature	0, +70	°C

THERMAL DATA

Symbol	Parameter	Value	Unit
$R_{th(j-a)}$	Junction-ambient Thermal Resistance	Typ. 70	°C/W

5715-02.TBL

RECOMMENDED OPERATING CONDITIONS ($T_{amb} = 25^{\circ}\text{C}$)

Symbol	Parameter	Min.	Typ.	Max.	Unit
V_{CC}	Power Supply Voltage	4.5	5	5.5	V
V_{REC}	Power Supply Voltage Record	4.75	11.3	12.6	V
CAGC	Capacitance at Pin CAGC	4.7			nF

5715-03.TBL

ELECTRICAL OPERATING CHARACTERISTICS ($T_{amb} = 25^{\circ}\text{C}$ unless otherwise specified)

Power Consumption

Parameter	Play-Back		Record (1)	
	Typ.	Max.	Typ.	Max.
V_{CC}	42mA	52mA	25mA	38mA
V_{REC}	0mA	0mA	25mA	33mA
Total Consumption (2)	$V_{CC} = 5V, V_{REC} = 9V$		350mW	
	$V_{CC} = 5.5V, V_{REC} = 9.45V$		286mW	521mW

5715-04.TBL

Notes : 1. $R1 = 18\Omega$

2. Taking in account only the consumption through the IC.

A great care should be taken to the maximum power consumption : V_{REC} can be increased to 12.6V if the DC current flowing through the head is reduced. This can be done by increasing $R1$ value. V_{REC} can be reduced as long as voltage on Pin I_{OUT} does not fall below 1V (to avoid output stage saturation).

Play-back Mode

 $V_{CC} = 5V$, no load on Pins CHROMA,LUMA

Symbol	Parameter	Test Conditions	Min.	Typ.	Max.	Unit
I_{CC1}	Supply Current		32	42	52	mA

CHROMA OUTPUT (no AGC)

G_{PB}	Pre-amplification Gain	Sinewave 600 kHz, 400mV _{PP} on output Input on Pin H1 or H2	56	59	62	dB
ΔG_{PB1}	Difference of Output Signal on Pin CHROMA between Channel 1 and Channel 2	Sinewave 600kHz 0.4mV _{PP} on inputs H1 and H2	-1.2	0	1.2	dB
e_N	Equivalent Input Voltage Noise Level	Input grounded via switching transistor on Pins H1, H2, $f = 600\text{kHz}$		0.6		nV/ $\sqrt{\text{Hz}}$
i_N	Equivalent Input Current Noise	Pins H1, H2		1.7		pA/ $\sqrt{\text{Hz}}$
CRT	Crosstalk	Sinewave 3.8MHz, 400 μV_{PP} on input, All the other inputs loaded with $R_g = 15\Omega$		-45	-40	dB
R_{PB}	Playback Switch-on Resistance	$\Delta I = 10\text{mA}$		2.0	5.0	Ω
F_{LCPB1} F_{HCPB1}	Bandwidth Cut-off Frequency	-3dB attenuation 50 Ω in parallel on the input, 0dB at 600kHz Low High	8	13.5	0.1	MHz MHz
C_{IN}	Input Capacitance Pins H1, H2	At 5MHz		30	40	pF
R_{IN}	Pre-amplifier Input Resistance Pins H1, H2	At 3.8MHz	400	600	900	Ω
Z_{CPB}	Output Impedance Pin CHROMA	DC		24	50	Ω

5715-05.TBL

ELECTRICAL OPERATING CHARACTERISTICS ($T_{amb} = 25^{\circ}\text{C}$ unless otherwise specified) (continued)**Play-back Mode** $V_{CC} = 5\text{V}$, no load on Pins CHROMA, LUMA

Symbol	Parameter	Test Conditions	Min.	Typ.	Max.	Unit
--------	-----------	-----------------	------	------	------	------

CHROMA OUTPUT (no AGC) (continued)

V_{DCPB1}	DC Level at Play-back Output on Pin CHROMA		1.5	1.9	2.3	V
ΔV_{DC}	Head Switch Offset Pin CHROMA		-100	0	100	mV
SH_{PB1}	Second Harmonic Play-back Output Pin CHROMA	Sinewave 3.8MHz 400 μV_{PP} on input		-45	-40	dB

LUMA OUTPUT (with AGC)

Z_{LPB}	Output Impedance	DC		30	50	Ω
V_{DCPB2}	DC Level		1.1	1.5	2.1	V
F_{LCPB2} F_{HCPB2}	Bandwidth Cut-off Frequency	-3dB attenuation 50 Ω in parallel on the input, AGC locked, 0dB at 3.8MHz Low High	10	12.5	0.1	MHz MHz
V_{LPB}	Output Amplitude	Input signal 200 μV_{PP} at 3.8MHz on Pins H1, H2	140	200	270	mV $_{PP}$
ΔV_{LPB}	AGC Control Sensitivity	Input signal 200 μV_{PP} at +6dB or -5dB on Pins H1, H2	-2		+1	dB
SH_{PB2}	Second Harmonic Play-back Output	Input Signal 3.8MHz 400 μV_{PP} on Pins H1, H2		-44	-39	dB

CAGC

I+	Positive Output Current	Input Signal 3.8MHz 200 μV_{PP} on H1	15	30	50	μA
I-	Negative Output Current	Input Signal 3.8MHz 200 μV_{PP} on H1	-50	-30	-15	μA

TRIV

I_{TRIV}	Downloading Current		200	300	400	μA
V_{TRIV1}	Output Level (1)	With no signal, $V_{TRIVADJ} = 2.5\text{V}$ Mode LP (SW-M = high)	0.3	0.6	1.5	V
V_{TRIV2}	Output Level (2)	$V_{CHROMA} = 100\text{mV}_{PP}$ at 4MHz $V_{TRIVADJ} = 2.5\text{V}$, Mode LP (SW-M = high)	1.91	2.31	2.91	V
V_{TRIV3}	Output Level (3)	$V_{CHROMA} = 400\text{mV}_{PP}$ at 4MHz $V_{TRIVADJ} = 2.5\text{V}$, Mode LP (SW-M = high)	3.525	3.725	3.985	V
V_{TRIV4}	Output Level (4)	$V_{CHROMA} = 100\text{mV}_{PP}$ at 4MHz $V_{TRIVADJ} = 1\text{V}$, Mode LP (SW-M = high)	1.110	1.610	2.311	V
V_{TRIV5}	Output Level (5)	$V_{CHROMA} = 100\text{mV}_{PP}$ at 4MHz $V_{TRIVADJ} = 4\text{V}$, Mode LP (SW-M = high)	2.875	3.075	3.335	V
V_{TRIV6}	Output Level (6)	$V_{CHROMA} = 400\text{mV}_{PP}$ at 4MHz $V_{TRIVADJ} = 2.5\text{V}$, Mode SP (SW-M = low)	3.215	3.415	3.675	V
V_{TRIV7}	Output Level (7)	$V_{CHROMA} = 100\text{mV}_{PP}$ at 4MHz $V_{TRIVADJ} = 2.5\text{V}$, Mode SP (SW-M = low)	1.65	2.05	2.65	V
f_{TRIV1}	Response Lower Frequency	$V_{CHROMA} = 400\text{mV}_{PP}$ at 4MHz and 1MHz $V_{TRIVADJ} = 2.5\text{V}$, Mode LP (SW-M = high)	-10	-6	-3	dB
f_{TRIV2}	Response Higher Frequency	$V_{CHROMA} = 400\text{mV}_{PP}$ at 8MHz and 4MHz $V_{TRIVADJ} = 2.5\text{V}$, Mode LP (SW-M = high)	-2.5	-1	-0	dB
G_{TRIV}	High Level Input	LP : $V_{CHROMA} = 100\text{mV}_{PP}$, 300mV $_{PP}$ at 4MHz, $V_{TRIVADJ} = 2.5\text{V}$	4	5.5	7	V/V

5715-06 TBL

ELECTRICAL OPERATING CHARACTERISTICS ($T_{amb} = 25^{\circ}\text{C}$ unless otherwise specified) (continued)

Record Mode
 $V_{REC} = 11.3\text{V}$, $V_{CC} = 5\text{V}$, Load resistor 50Ω on Pin I_{OUT}

 Transconductance network defined by :
 $R1 = 18\Omega$, 1%
 $R2 = 1.5\text{k}\Omega$, 1%
 $R3 = 1.5\text{k}\Omega$, 1%
Pins GND/V_{MES}Pins V_{MES}/V_{IN}Pin V_{IN}

Symbol	Parameter	Test Conditions	Min.	Typ.	Max.	Unit
I _{REC} I _{CC2}	Current Supply	V _{REC} = 11.3V V _{CC} = 5V	17 15	25 25	33 38	mA mA
I _{max}	Max. Record Current	3.8MHz	35			mA _{PP}
TR	Transconductance	V _{IN} = 300mV _{PP}	45	55	65	mA/V
SH _{REC}	Second Harmonic	Output Current, 30mA _{PP} at 3.8MHz at Pin I _{OUT}		-54	-38	dB
F _{LCR} F _{HCR}	Bandwidth Cut-off Frequency Pin I _{OUT}	-3dB attenuation, 0dB at 3.8MHz Output current 30mA _{PP} Low High	10		0.1	MHz MHz
R _{VIN}	Input Resistance on Pin V _{IN}	Equivalent value of R3 resistor	500	700	900	Ω

5715-07.TBL

Switching Levels

Symbol	Parameter	Test Conditions	Min.	Typ.	Max.	Unit
V _{SWHH}	Head Selection Pin SW-H	Head number 1	2.4		V _{CC}	V
V _{SWHL}		Head number 2	0		1.5	V
I _{SWHH}		Input current (5V)	5	15	50	μA
I _{SWHL}		Output current (0V)	-50	-20	0	μA
V _{SWMH}	Mode Selection Pin SW-M	LP Mode	2.4		5	V
V _{SWML}		SP mode	0		1.5	V
I _{SWMH}		Input current (5V)	5	15	50	μA
I _{SWML}		Output current (0V)	-50	-20	0	μA
t _{ON} t _{OFF}	Selection Pin SW-H Transient Response	Output signal appears on Pin CHROMA Delay time selection ON Delay time selection OFF		100 100	500 500	ns
V _{TH1}	Inhibition Threshold Hysteresis for Switching from Play-back to record on Pin V _{REC}	V _{CC} = 5V	0.15	0.3	0.5	V
V _{TH2}	Inhibition Threshold Hysteresis for Switching from Record to Play-back on Pin V _{REC}	V _{CC} = 5V		80		mV
t ₁	Transient Response of Record Scanning on Pin V _{REC}	Delay from play-back to record (signal disappears on Pin CHROMA)		10		μs
t ₂		Delay from record to play-back (signal appears on Pin CHROMA)		32*		ms
t ₃		Delay from play-back to record (signal appears on Pin I _{OUT})		0.2		ms
t ₄		Delay from record to play-back (signal disappears on Pin I _{OUT})		11*		ms

5715-08.TBL

 * Depending on capacitance on Pin V_{REC} ; above values are according to the application diagram at page 9.

INPUT/OUTPUTS EQUIVALENT INTERNAL DIAGRAM

Pins : C1, C2

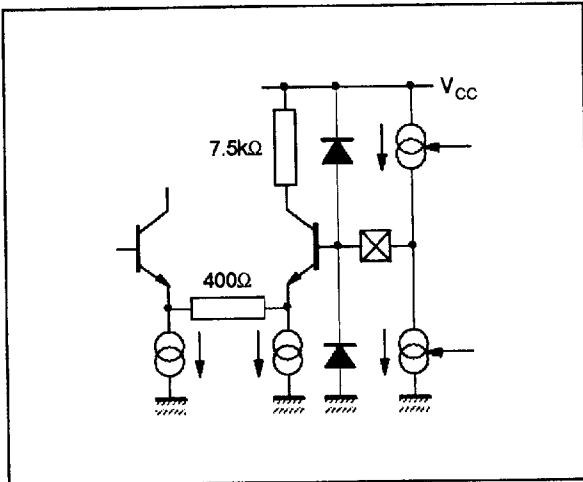

5715-03.EPS

Pins : SW-H, SW-M

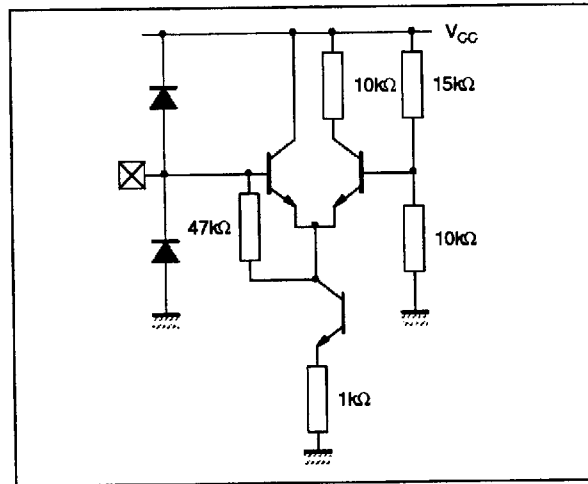

5715-04.EPS

Pins : Chroma, Luma

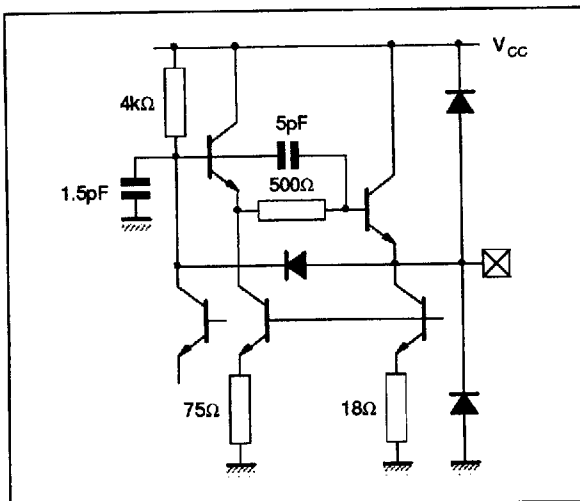

5715-05.EPS

Pin : VMES

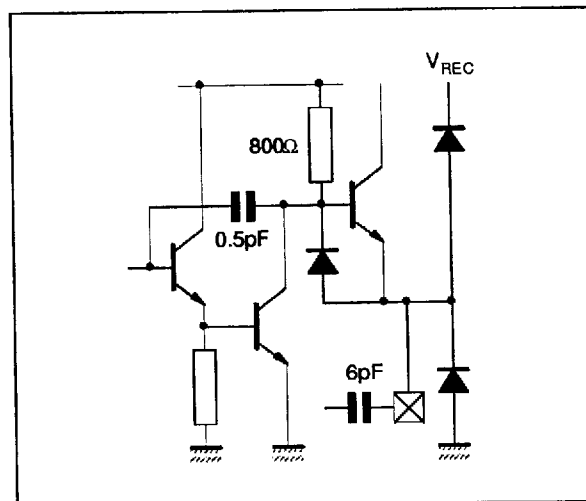

5715-06.EPS

Pin : VIN

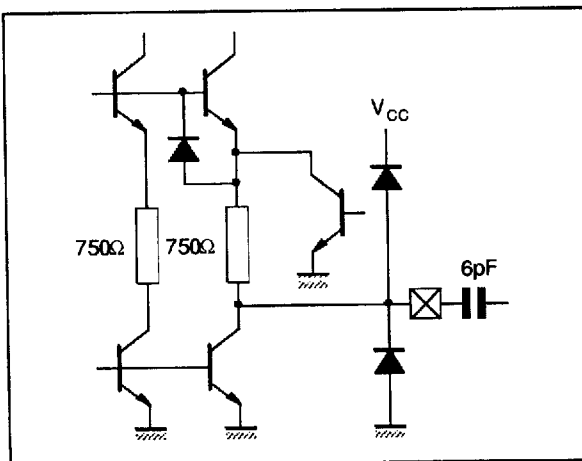

5715-07.EPS

Pin : CAGC

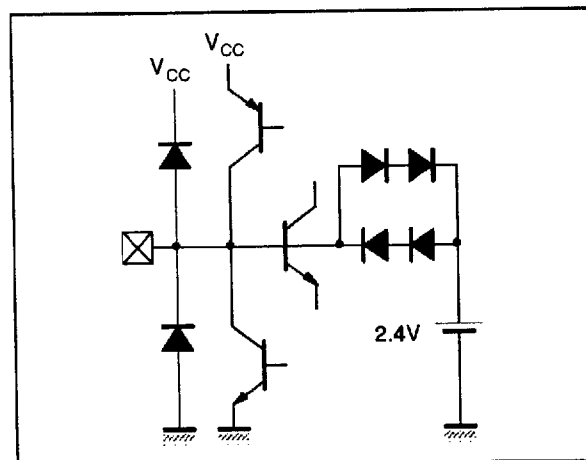

5715-08.EPS

INPUT/OUTPUTS EQUIVALENT INTERNAL DIAGRAM (continued)

Pin : TRIV

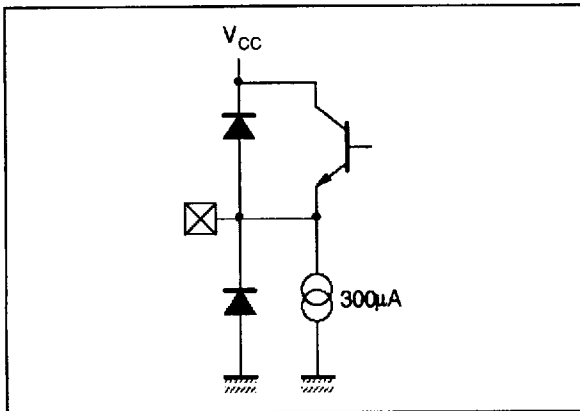

5715-09.EPS

Pin : TRIVADJ

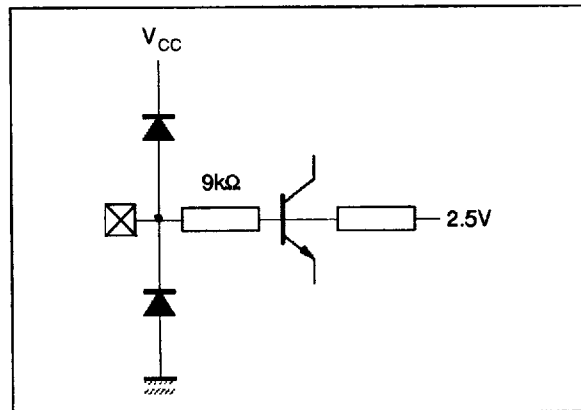

5715-10.EPS

Pin : Vcc

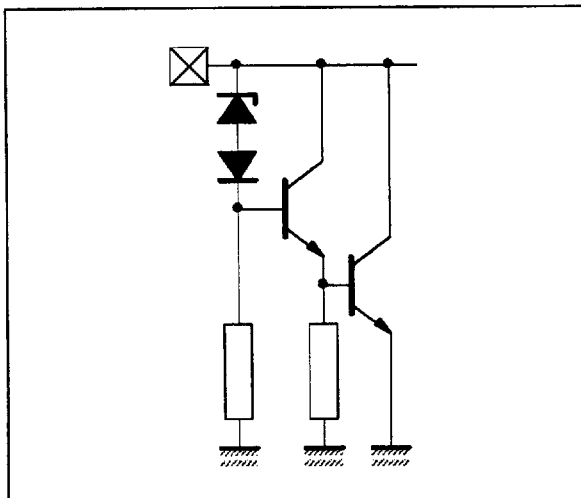

5715-11.EPS

Pin : VREC

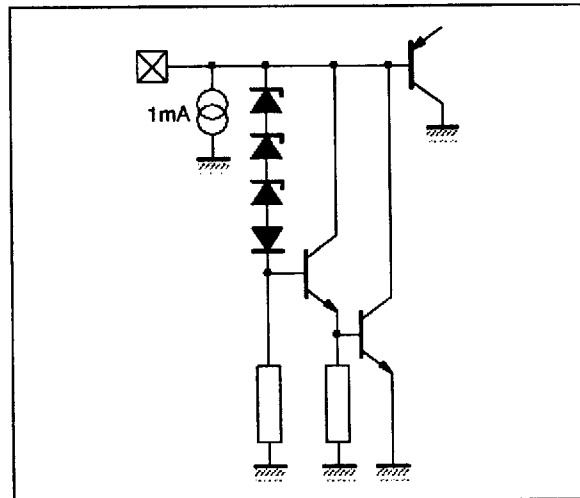

5715-12.EPS

Pin : Iout

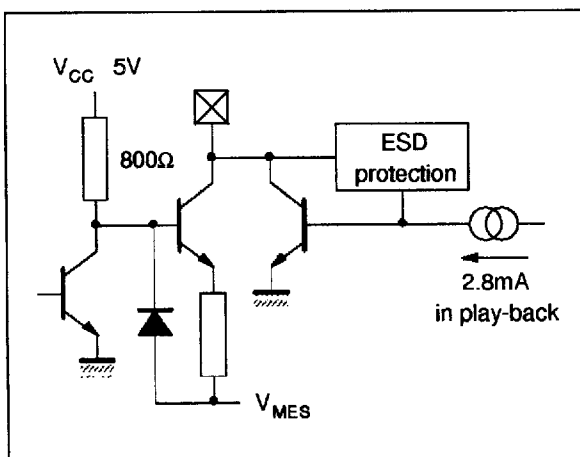

5715-13.EPS

Pins : CCAS, H1, H2

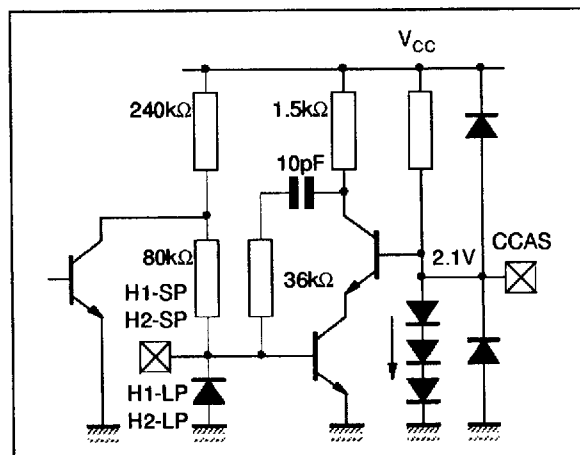

5715-14.EPS

APPLICATION DIAGRAM

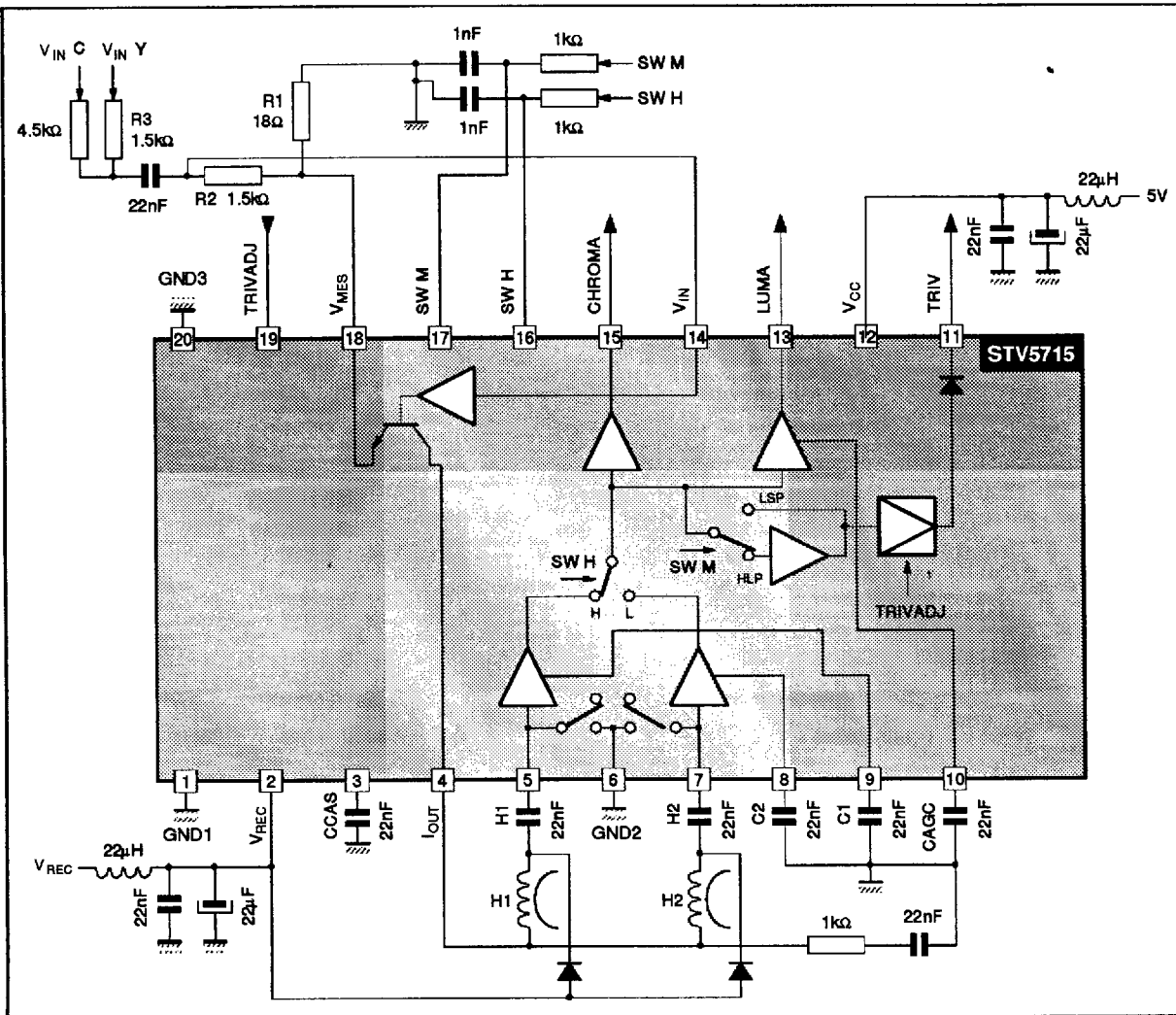

5715-15 EPS

PACKAGE MECHANICAL DATA
20 PINS - PLASTIC MICROPACKAGE

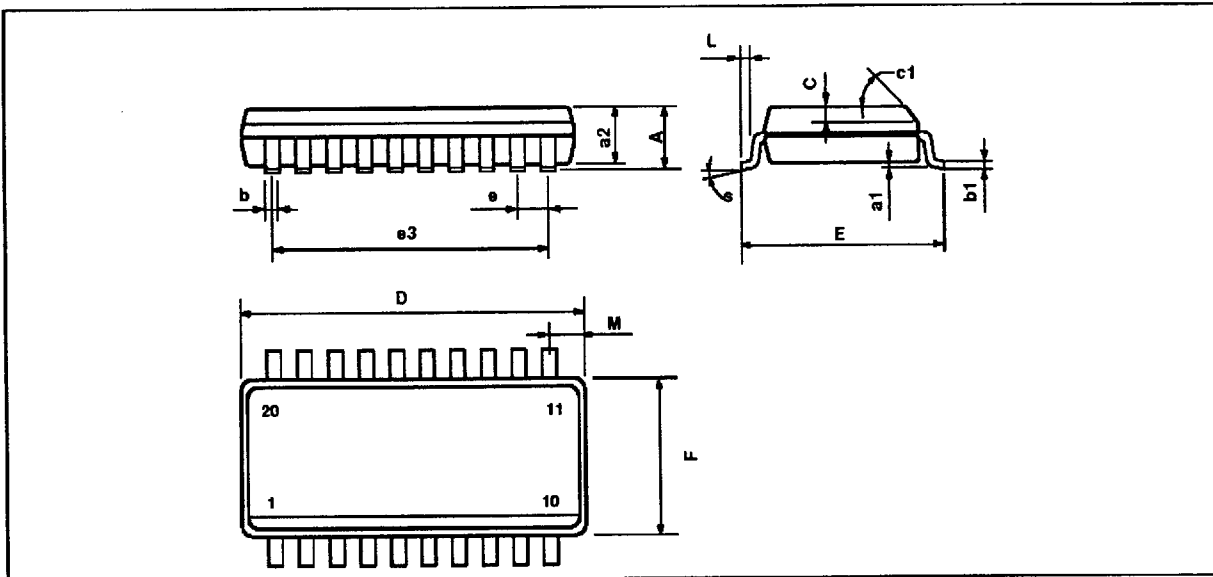

PM-S020L.EPS

Dimensions	Millimeters			Inches		
	Min.	Typ.	Max.	Min.	Typ.	Max.
A			2.65			0.104
a1	0.1		0.2	0.004		0.008
a2			2.45			0.096
b	0.35		0.49	0.014		0.019
b1	0.23		0.32	0.009		0.013
C		0.5			0.020	
c1	45° (typ.)					
D	12.6		13.0	0.496		0.510
E	10		10.65	0.394		0.419
e		1.27			0.050	
e3		11.43			0.450	
F	7.4		7.6	0.291		0.300
L	0.5		1.27	0.020		0.050
M			0.75			0.030
S	8° (max.)					

S0220L.TBL

Information furnished is believed to be accurate and reliable. However, SGS-THOMSON Microelectronics assumes no responsibility for the consequences of use of such information nor for any infringement of patents or other rights of third parties which may result from its use. No licence is granted by implication or otherwise under any patent or patent rights of SGS-THOMSON Microelectronics. Specifications mentioned in this publication are subject to change without notice. This publication supersedes and replaces all information previously supplied. SGS-THOMSON Microelectronics products are not authorized for use as critical components in life support devices or systems without express written approval of SGS-THOMSON Microelectronics.

© 1994 SGS-THOMSON Microelectronics - All Rights Reserved

Purchase of μ C Components of SGS-THOMSON Microelectronics, conveys a license under the Philips μ C Patent. Rights to use these components in a μ C system, is granted provided that the system conforms to the μ C Standard Specifications as defined by Philips.

SGS-THOMSON Microelectronics GROUP OF COMPANIES

Australia - Brazil - China - France - Germany - Hong Kong - Italy - Japan - Korea - Malaysia - Malta - Morocco
 The Netherlands - Singapore - Spain - Sweden - Switzerland - Taiwan - Thailand - United Kingdom - U.S.A.