

**TV VERTICAL DEFLECTION OUTPUT CIRCUIT**

The functions incorporated are :

- POWER AMPLIFIER
- FLYBACK GENERATOR
- REFERENCE VOLTAGE
- THERMAL PROTECTION

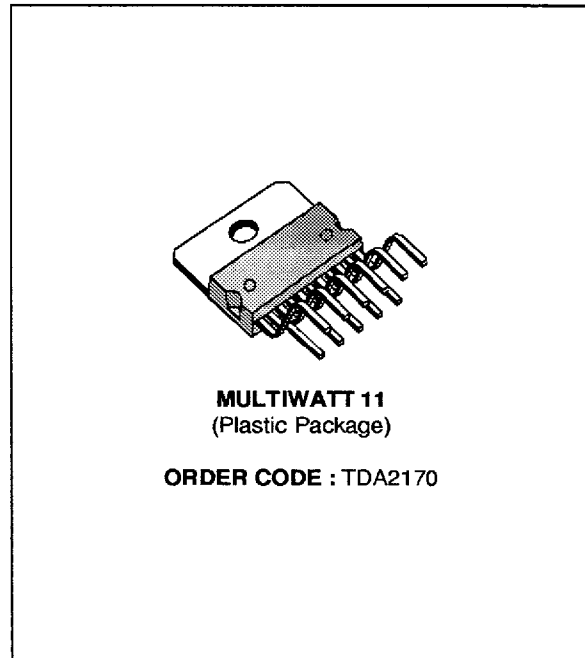

**DESCRIPTION**

The TDA2170 is a monolithic integrated circuit in 11-lead Multiwatt® package. It is a high efficiency power booster for direct driving of vertical windings of TV yokes. It is intended for use in Colour and B & W television receivers as well as in monitors and displays.

**PIN CONNECTIONS**

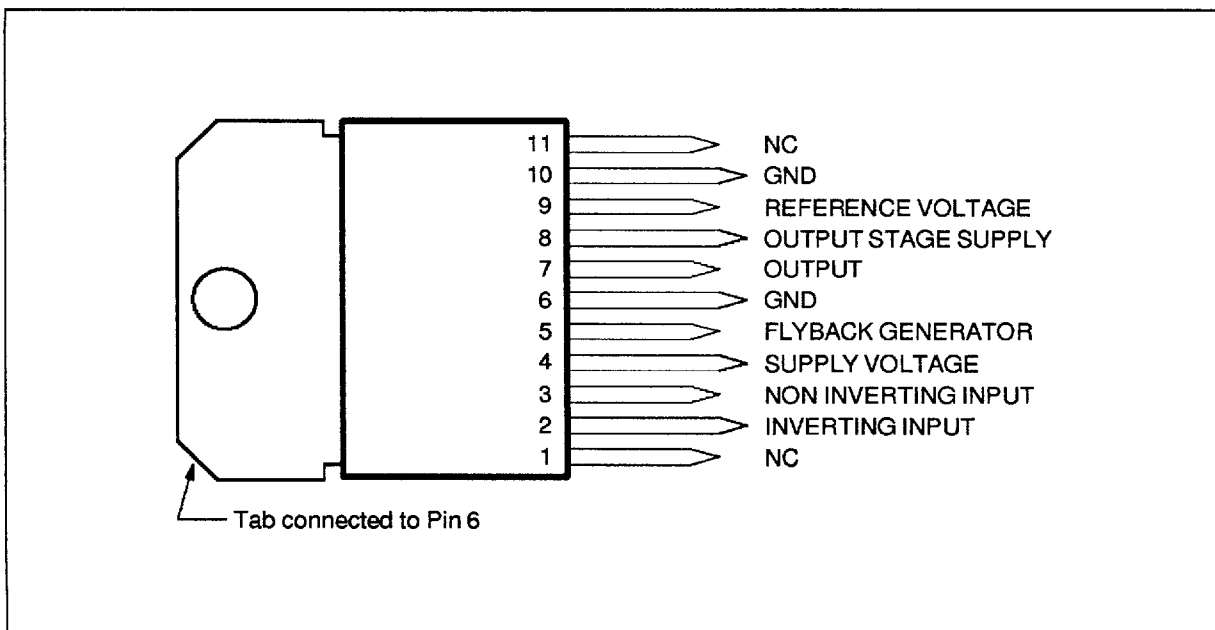

2170-01.EPS

**BLOCK DIAGRAM**

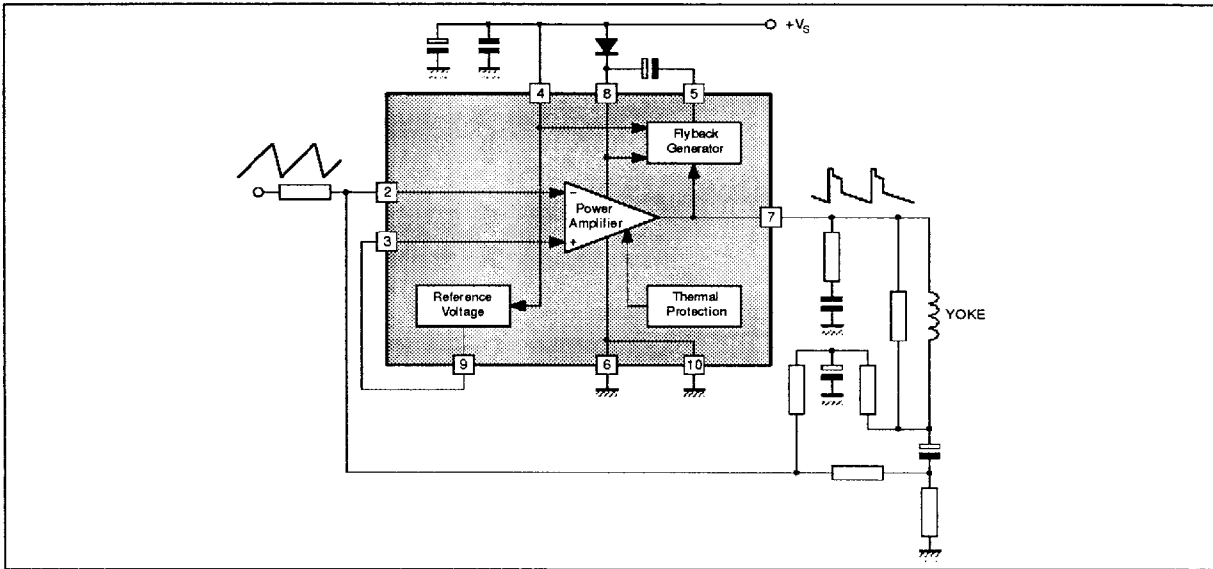

2170-02.EPS

**SCHEMATIC DIAGRAM**

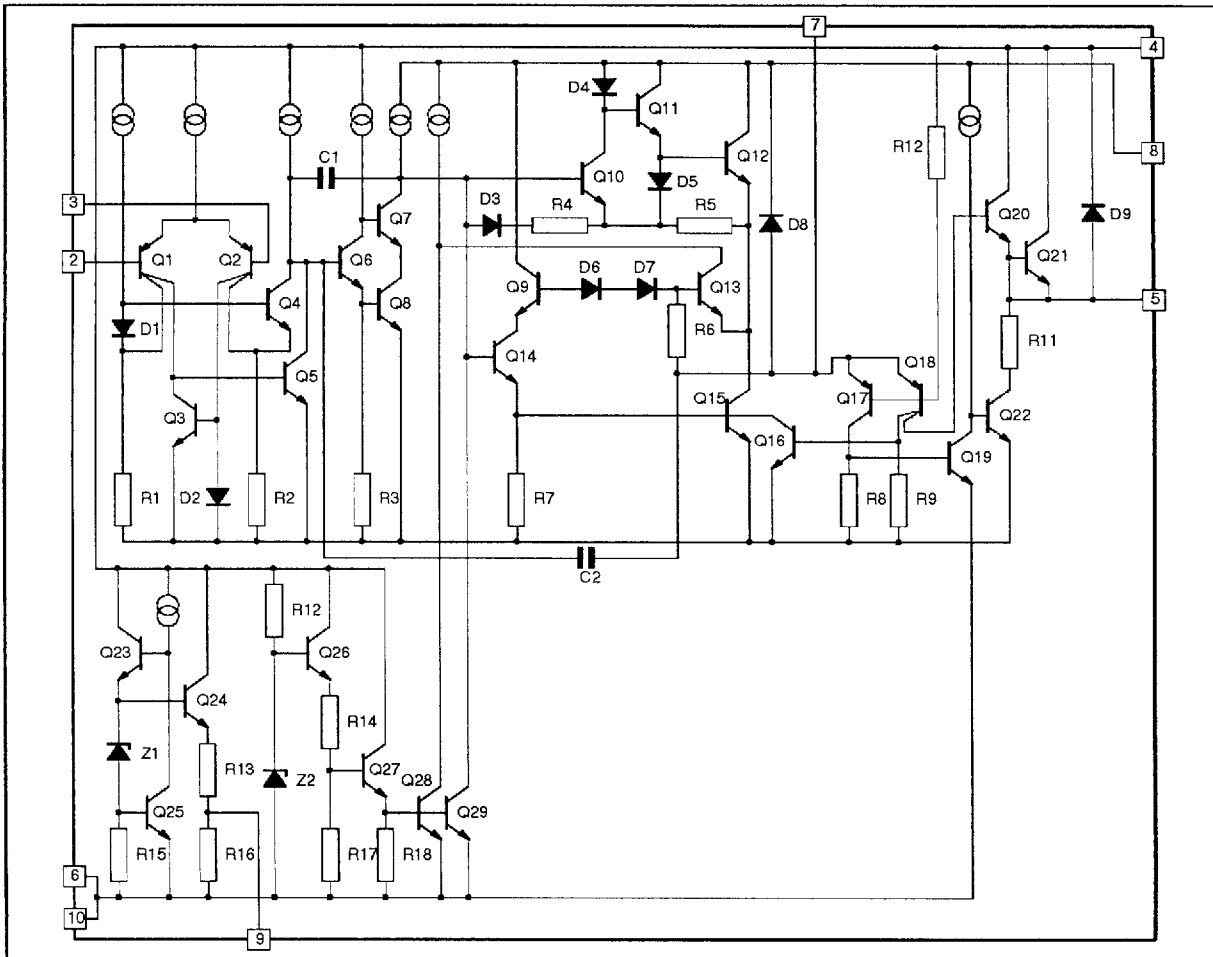

2170-03.EPS

## ABSOLUTE MAXIMUM RATINGS

Symbol	Parameter	Value	Unit
$V_s$	Supply Voltage (pin 4)	35	V
$V_7, V_8$	Flyback Peak Voltage	60	V
$V_5$	Voltage at Pin 5	$+ V_s$	
$V_2, V_3$	Amplifier Input Voltage	$+ V_s - 0.5$	V
$I_o$	Output Peak Current (non repetitive, $t = 2$ msec)	2.5	A
$I_o$	Output Peak Current at $f = 50$ Hz, $t \leq 10$ $\mu$ sec	3	A
$I_o$	Output Peak Current at $f = 50$ Hz, $t > 10$ $\mu$ sec	2	A
$I_5$	Pin 5 DC Current at $V_7 < V_4$	100	mA
$I_5$	Pin 5 Peak to Peak Flyback Current at $f = 50$ Hz, $t_{fly} \leq 1.5$ msec	3	A
$P_{tot}$	Total Power Dissipation at $T_{case} = 60$ °C	30	W
$T_{stg}, T_j$	Storage and Junction Temperature	- 40 to 150	°C

2170-01.TBL

## THERMAL DATA

Symbol	Parameter	Value	Unit
$R_{th(j-c)}$	Thermal Resistance Junction-case Max	3	°C/W
$R_{th(j-a)}$	Thermal Resistance Junction-ambient Max	40	°C/W

2170-02.TBL

## ELECTRICAL CHARACTERISTICS

(refer to the test circuits,  $V_s = 35$  V,  $T_{amb} = 25$  °C unless otherwise specified)

Symbol	Parameter	Test Conditions	Min.	Typ.	Max.	Unit	Fig.
$I_4$	Pin 4 Quiescent Current	$I_5 = 0$ ; $I_7 = 0$ ; $V_3 = 3$ V		8	16	mA	1a
$I_8$	Pin 8 Quiescent Current	$I_5 = 0$ ; $I_7 = 0$ ; $V_3 = 3$ V		16	36	mA	1a
$I_3$	Amplifier Input Bias Current	$V_3 = 1$ V		- 0.1	- 1	$\mu$ A	1a
$I_2$	Amplifier Input Bias Current	$V_2 = 1$ V		- 0.1	- 1	$\mu$ A	1a
$V_9$	Reference Voltage	$I_9 = 0$		2.2		V	1a
$\frac{\Delta V_9}{\Delta V_s}$	Reference Voltage Drift vs. Supply Voltage	$V_s = 15$ to 30 V		1	2	mV/V	1a
$V_{5L}$	Pin 5 Saturation Voltage to GND	$I_5 = 20$ mA		1		V	1c
$V_7$	Quiescent Output Voltage	$V_s = 35$ V; $R_a = 13$ k $\Omega$		18		V	1d
		$V_s = 15$ V; $R_a = 13$ k $\Omega$		7.5		V	1d
$V_{7L}$	Output Saturation Voltage to GND	$I_7 = 1.2$ A		1	1.4	V	1c
		$I_7 = 0.7$ A		0.7	1	V	1c
$V_{7H}$	Output Saturation Voltage to Supply	- $I_7 = 1.2$ A		1.6	2.2	V	1b
		- $I_7 = 0.7$ A		1.3	1.8	V	1b
$R_9$	Reference Voltage Output Resistance			2.1		k $\Omega$	
$T_j$	Junction Temperature for Thermal Shut Down			140		°C	

2170-03.TBL



Figure 3 : PC Board and Component Layout (1:1 scale)

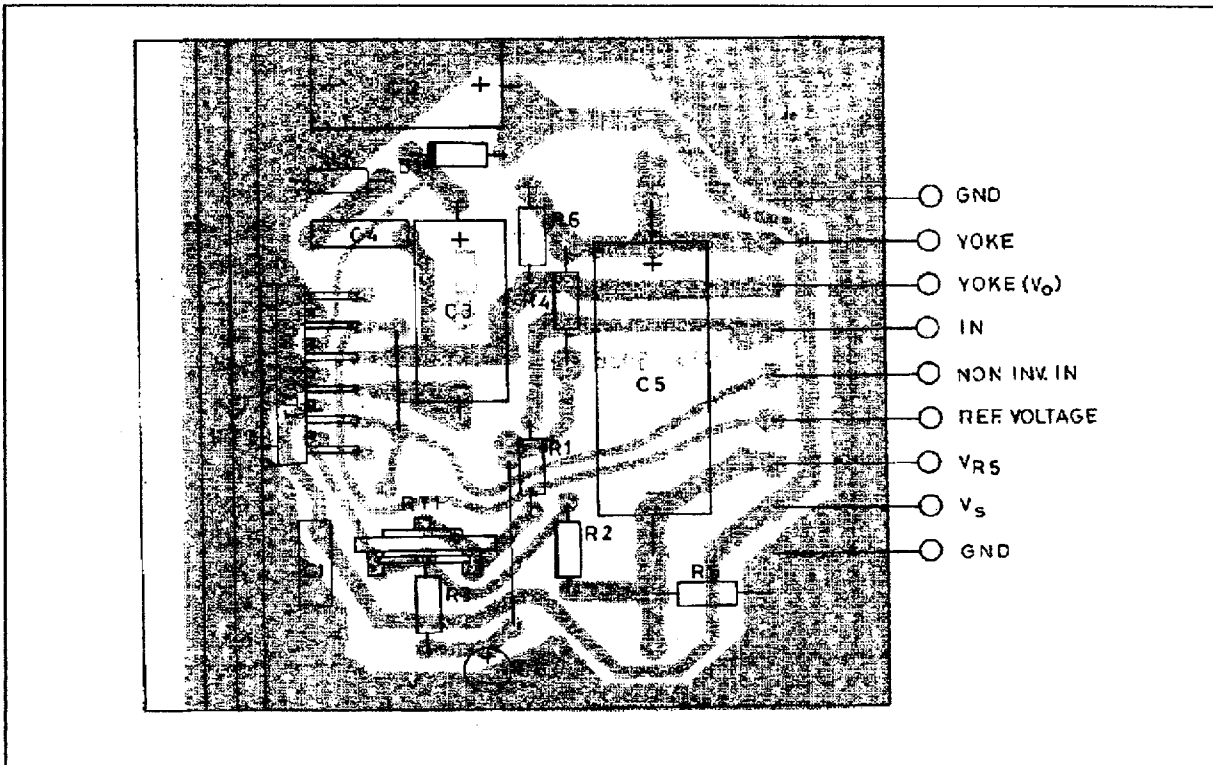

COMPONENTS LIST FOR TYPICAL APPLICATIONS

Component	110° TVC 5.9 Ω / 10 mH 1.95 App	110° TVC 9.6 Ω / 24.6 mH 1.2 App	90° TVC 15 Ω / 30 mH 0.82 App	Unit
RT1	10	4.7	10	kΩ
R1	12	10	12	kΩ
R2	10	5.6	5.6	kΩ
R3	27	12	18	kΩ
R4	12	8.2	5.6	kΩ
R5	0.82	1	1	Ω
R6	270	330	330	Ω
R7	1.5	1.5	1.5	Ω
D1	1N 4001	1N 4001	1N 4001	-
C1	0.1	0.1	0.1	μF
C2 el.	1000/25 V	470/25 V	470/25 V	μF
C3 el.	220/25 V	220/25 V	220/25 V	μF
C4	0.22	0.22	0.22	μF
C5 el.	2200/25 V	2200/25 V	1000/16 V	μF
C6 el.	4.7/16 V	4.7/16 V	10/16 V	μF

**TYPICAL PERFORMANCES**

Parameter	110° TVC 5.9 Ω / 10 mH	110° TVC 9.6 Ω / 27 mH	90° TVC 15 Ω / 30 mH	Unit
V <sub>s</sub> – Supply Voltage	24	22.5	25	V
I <sub>s</sub> – Current	280	175	125	mA
t <sub>fly</sub> – Flyback Time	0.6	1	0.7	ms
* P <sub>tot</sub> – Power Dissipation	4.2	2.5	2.05	W
* R <sub>th c-a</sub> – Heatsink	7	13	16	°C/W
T <sub>amb</sub>	60	60	60	°C
T <sub>j max</sub>	110	110	110	°C
t <sub>o</sub>	20	20	20	ms
V <sub>i</sub>	2.5	2.5	2.5	V <sub>PP</sub>
V <sub>7</sub>	50	47	52	V <sub>P</sub>

\* Worst case condition.

**MOUNTING INSTRUCTIONS**

The power dissipated in the circuit must be removed by adding an external heatsink.

Thanks to the MULTIWATT® package attaching the heatsink is very simple, a screw or a compression spring (clip) being sufficient.

Between the heatsink and the package it is better to insert a layer of silicon grease, to optimize the thermal contact ; no electrical isolation is needed between the two surfaces.

**Figure 2 : Application Circuit**

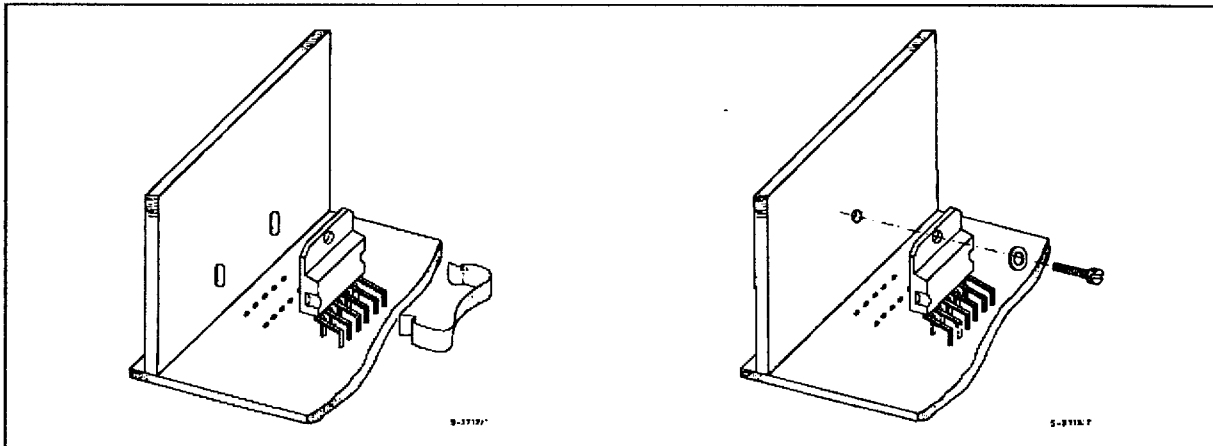

**Figure 5 : Maximum Allowable Power Dissipation versus Ambient Temperature**

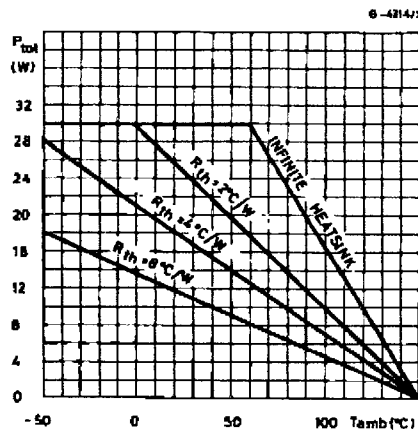

**PACKAGE MECHANICAL DATA**  
11 PINS - PLASTIC MULTIWATT

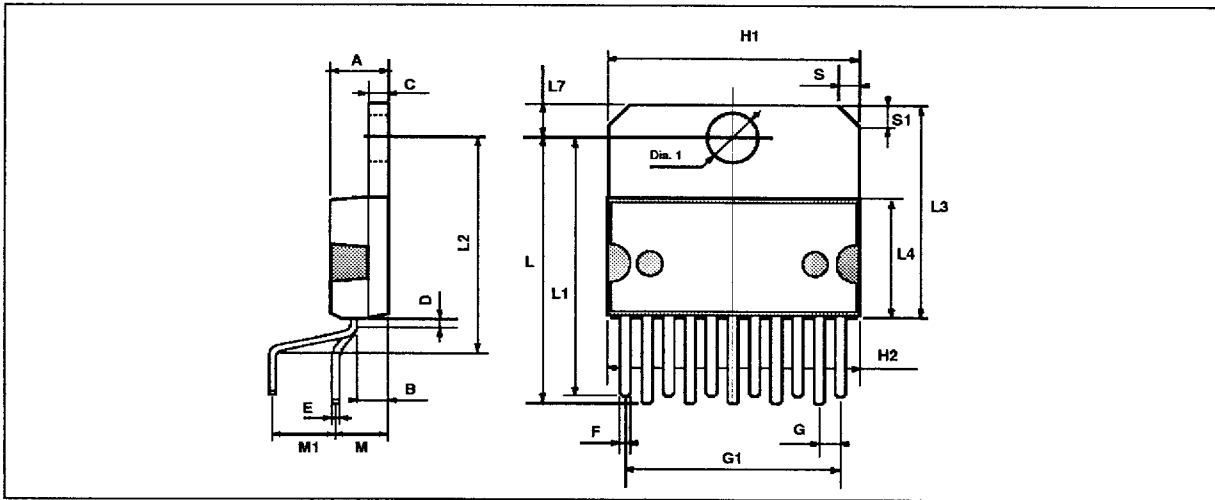

PMMULT1V.EPS

Dimensions	Millimeters			Inches		
	Min.	Typ.	Max.	Min.	Typ.	Max.
A			5			0.197
B			2.65			0.104
C			1.6			0.063
E	0.49		0.55	0.019		0.022
F	0.88		0.95	0.035		0.037
G	1.57	1.7	1.83	0.062	0.067	0.072
G1	16.87	17	17.13	0.664	0.669	0.674
H1	19.6			0.772		
H2			20.2			0.795
L	21.5		22.3	0.846		0.878
L1	21.4		22.2	0.843		0.874
L2	17.4		18.1	0.685		0.713
L3	17.25	17.5	17.75	0.679	0.689	0.699
L4	10.3	10.7	10.9	0.406	0.421	0.429
L7	2.65		2.9	0.104		0.114
M	4.1	4.3	4.5	0.161	0.169	0.177
M1	4.88	5.08	5.3	0.192	0.200	0.209
S	1.9		2.6	0.075		0.102
S1	1.9		2.6	0.075		0.102
Dia. 1	3.65		3.85	0.144		0.152

MULTIV.TBL

Information furnished is believed to be accurate and reliable. However, SGS-THOMSON Microelectronics assumes no responsibility for the consequences of use of such information nor for any infringement of patents or other rights of third parties which may result from its use. No licence is granted by implication or otherwise under any patent or patent rights of SGS-THOMSON Microelectronics. Specifications mentioned in this publication are subject to change without notice. This publication supersedes and replaces all information previously supplied. SGS-THOMSON Microelectronics products are not authorized for use as critical components in life support devices or systems without express written approval of SGS-THOMSON Microelectronics.

© 1994 SGS-THOMSON Microelectronics - All Rights Reserved

Purchase of  $\int$ C Components of SGS-THOMSON Microelectronics, conveys a license under the Philips  $\int$ C Patent. Rights to use these components in a  $\int$ C system, is granted provided that the system conforms to the  $\int$ C Standard Specifications as defined by Philips.

SGS-THOMSON Microelectronics GROUP OF COMPANIES

Australia - Brazil - China - France - Germany - Hong Kong - Italy - Japan - Korea - Malaysia - Malta - Morocco  
The Netherlands - Singapore - Spain - Sweden - Switzerland - Taiwan - Thailand - United Kingdom - U.S.A.

**SGS-THOMSON**  
MICROELECTRONICS

7/7

7929237 0074797 466