

**WIDE BAND VIDEO PREAMPLIFIER**

PRELIMINARY DATA

- CURRENT OUTPUT (up to 300mA)
- 120MHz (-3dB) BANDWIDTH
- 3nsec RISE/FALL TIME
- BRIGHTNESS AND CONTRAST DC CONTROLLED
- INTERNAL CLAMPING PULSE GENERATOR
- CONTRAST PRE-ADJUST FOR COLOR MONITOR APPLICATION
- INTERNAL REFERENCE VOLTAGE GENERATOR
- BLANKING PULSE INPUT
- POS/NEG SYNC POLARITY INPUT

**DESCRIPTION**

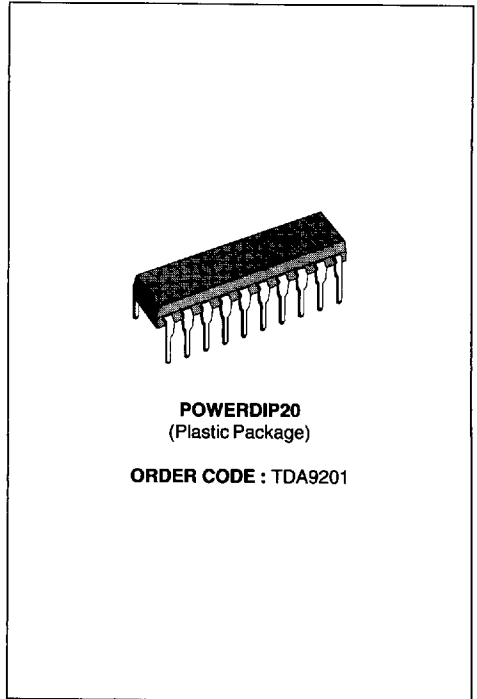
The TDA9201 is a wide band video amplifier intended for high resolution monochrome or color monitors.

The BRIGHTNESS and CONTRAST are DC controlled.

The brightness loop includes a comparator gated by an internally generated pulse.

Thanks to the contrast pre-adjust pin, this device is well suited for color application too.

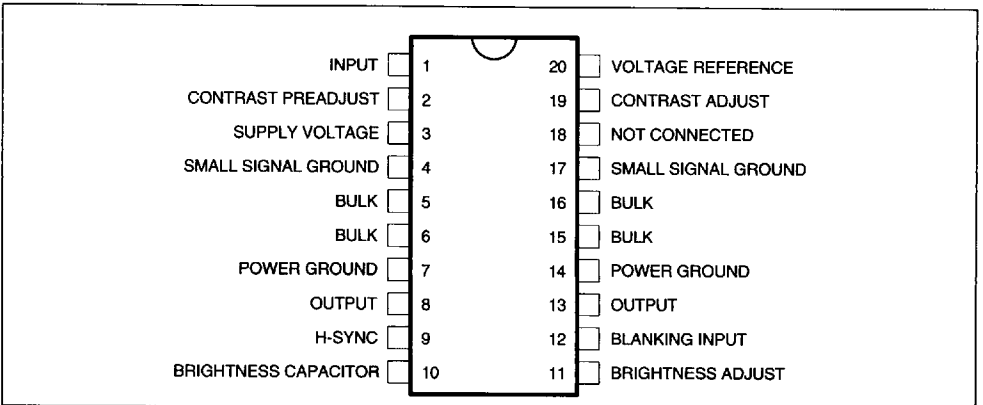
The output stage structure (A class current output), allows to use a very cheap high voltage amplifier using only one transistor.



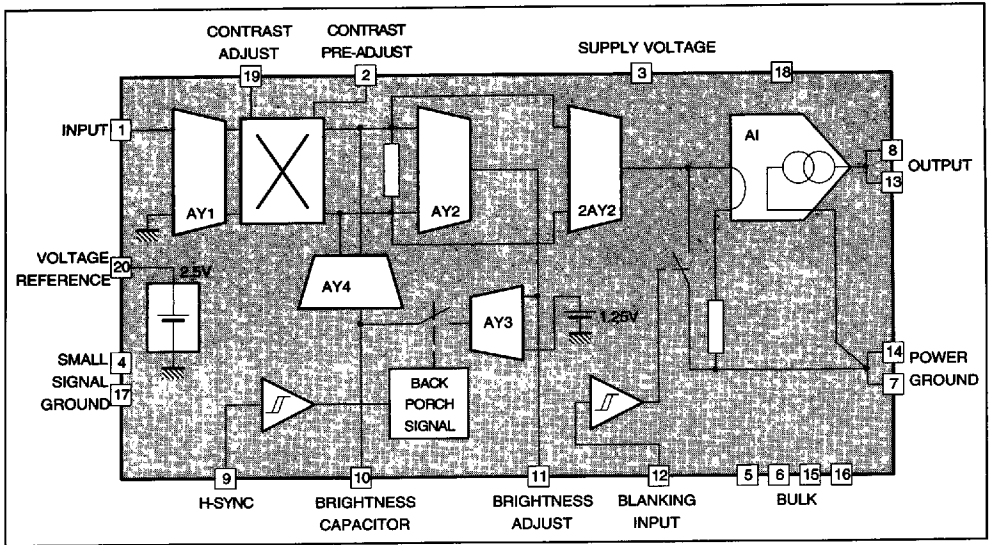
**POWERDIP20**  
(Plastic Package)

**ORDER CODE : TDA9201**

**PIN CONNECTIONS**



**BLOCK DIAGRAM**



9201-02 EPL

**ABSOLUTE MAXIMUM RATINGS**

Symbol	Parameter	Value	Unit	
$V_S$	Power Supply (Pin 3)	8	V	
$I_{OUT}$	Output Current	350	mA	
$V_{IN}$	Voltage at any Input Pin	-0.3, $V_S$	V	
$T_J$	Junction Temperature	0, +150	°C	
$T_{stg}$	Storage Temperature	-40, +150	°C	
$P_{max}$	Power Dissipation	$T_{PINS} = 90^{\circ}C$	4.3	W
		$T_{amb} = 70^{\circ}C$	1	W

9201-01 TEL

**THERMAL DATA**

Symbol	Parameter	Value	Unit
$R_{th(j-p)}$	Junction-Pins Thermal Resistance	Max. 14	°C/W
$R_{th(j-a)}$	Junction-ambient Thermal Resistance	Max. 80*	°C/W

\* Obtained with GND pins soldered to printed board with minimum area.

9201-02 TEL

**DC ELECTRICAL CHARACTERISTICS** ( $V_S = 5V$  and  $T_{amb} = 25^\circ C$ , unless otherwise specified)

Symbol	Parameter	Test Conditions	Min.	Typ.	Max.	Unit
$V_S$	Supply Voltage Range	Pin 3	4.5	5	5.5	V
$I_S$	Supply Current	$V_S = 5V$ , Pin 3		82	100	mA
$V_{REF}$	Voltage Reference	$I_{20} = 0$ , Pin 20	2.30	2.42	2.55	V
$I_{REF}$	Max. Current from Pin 20 to ground	Pin 20			5	mA
$V_1$	Input DC Level	Pin 1	0.7	0.8	0.9	V
$R_1$	Input Impedance	Pin 1		10		k $\Omega$
$I_2$	Cont Pre-adjust Current from Pin 2 to ground		0.3	0.5	0.7	mA
$V_{CONT}$	Voltage Range on Contrast Adjust	Pin 19	0		$V_2$	V
$I_{BRTX}$	Current for Max. Brightness (100mA on output pin)	Current from Pin 11 to ground (see Figure 1)		340		$\mu A$
$I_{BRTI}$	Current for Min. Brightness (100mA on output pin)	Current from Pin 11 to ground (see Figure 1)		64		$\mu A$
$I_{offs}$	DC Offset Current on Pin 11	Pin 11		$\pm 50$		$\mu A$
$V_{OI}$	Min. Output Voltage for normal operating	Pin 13 or/and 8	3.5			V

9201-03 TBL

**AC ELECTRICAL CHARACTERISTICS** ( $V_S = 5V$  and  $T_{amb} = 25^\circ C$ , unless otherwise specified)

Symbol	Parameter	Test Conditions	Min.	Typ.	Max.	Unit
$V_{DI}$	Max. Peak-to-peak Input Voltage	Pin 1 (without sync)			1	V
$V_{thH}$	Sync. and Blank Inputs Threshold Voltage (Pins 9 and 12)	Low level High Level	2		0.8	V V
$I_{SYNC}$	Current On Sync. Input (Pin 9)	Low level High Level			1 5	$\mu A$ $\mu A$
$I_{BLANK}$	Current On Blank Input (Pin 12)	Low level High Level			-50 1	$\mu A$ $\mu A$
$BLK_{D1}$	Delay between Blanking Pulse beginning and Output Inhibition	Pins 8, 12 and 13			40	nsec
$BLK_{D2}$	Delay between End of Blanking Pulse and Output Current Switching on	Pins 8, 12 and 13			30	nsec
$I_{OBLK}$	Output Current during Blanking Pulse	Pins 8 and 13 (see note 1)			100	$\mu A$
$I_{OR}$	Output Current Range Outside of Blanking	Pins 8 and 13 (see note 1)	300			mA
$dI_O$	Max. Peak-to-peak Output Current	Pins 8 and 13 (see note 1)			225	mA
BW	Min. Small Signal Bandwidth (-3dB) (see note 2)	$V_{CONT} = 0.8V$ , $V_{IN} = 100mV_{PP}$ , $I_{OUTDC} = 50mA$ (BRT), $V_{preset} = 2V$	120			MHz
$t_F, t_R$	Output Current Rise and Fall Time (10 to 90%) (see note 2)	Pins 8 and 13 (see note 1)			3	ns

**INTERNAL BACK POARCH CLAMPING PULSE GENERATOR**

$I_{10}$	Gated Current on Brightness Capacitor	Measured on Pin 10, 500ns after end of H-sync on Pin 9		500		$\mu A$
SPW1	Max. Sync Pulse Width	Pin 9			5	$\mu s$
SPW2	Min. Sync Pulse Width	Pin 9	1			$\mu s$
BPW	Back Poarch Pulse Width	Internal Pulse		1	1.3	$\mu s$

9201-04 TBL

- Notes :**
- $V_{CONT} = 0$ ,  $I_{BRT}$  adjusted for having  $I_{OUTDC} = 50mA$  outside of BLK.
  - This parameter is not tested in production but is guaranteed by the design and quality by means of corner lots during the qualification of the product in SGS-THOMSON. This parameter is measured on a AC testing board as described in Figure 2.

**AC ELECTRICAL CHARACTERISTICS** (continued)

$V_S = 5V$  and  $T_{amb} = 25^\circ C$ , unless otherwise specified

Symbol	Parameter	Test Conditions	Min.	Typ.	Max.	Unit
<b>TYPICAL CONTRAST CHARACTERISTICS</b>						
$G_{Nom}$	Gain Reference Value	$V_{IN} = 1V_{PP}$ , $V_{CONT} = 0.8V$ , Precontrast is presetted for having $I_{OUT} = 125mA_{PP}$		0		dB
GL1		$V_{CONT} = 0.2$ ( $V_{IN} = 1V_{PP}$ )	-12.46	-11.86	-11.26	dB
GL2		$V_{CONT} = 0.4$ ( $V_{IN} = 1V_{PP}$ )	-5.9	-5.6	-5.3	dB
GL3		$V_{CONT} = 1.2$ ( $V_{IN} = 1V_{PP}$ )	2.85	3.15	3.45	dB
GL4		$V_{CONT} = 1.6$ ( $V_{IN} = 1V_{PP}$ )	4.95	5.55	6.15	dB
GL5		$V_{CONT} = 0$ ( $V_{IN} = 1V_{PP}$ )	-35			dB

**BRIGHTNESS CHARACTERISTICS**

BRTx	Max. DC Current on Output				100	mA
BRTI	Min. DC Current on Output	for full bandwidth	10			mA
GBRT	Brightness Control Characteristic $I_{out DC} / I_{I11}$	DC current output versus $I_{I11}$ ( $I_{I11}$ in Pin 11 flows from Pin 11 to GND)		326		
$V_2$	Voltage Range		0		$V_{REF}$	V
$V_{nom}$	Voltage for Odb Adjustment ( $G_{nom}$ )	$V_2$		2		V

**Figure 1 : Details of Brightness Adjustment**

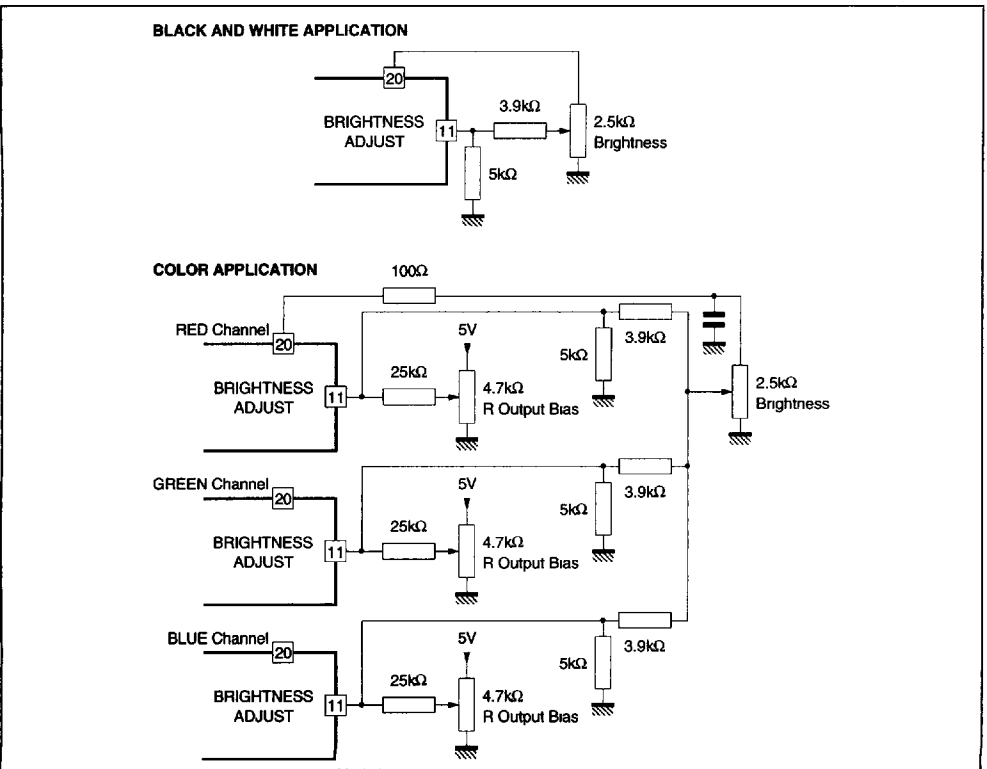


Figure 2 : AC Test Circuit for BW and Rt/Ft

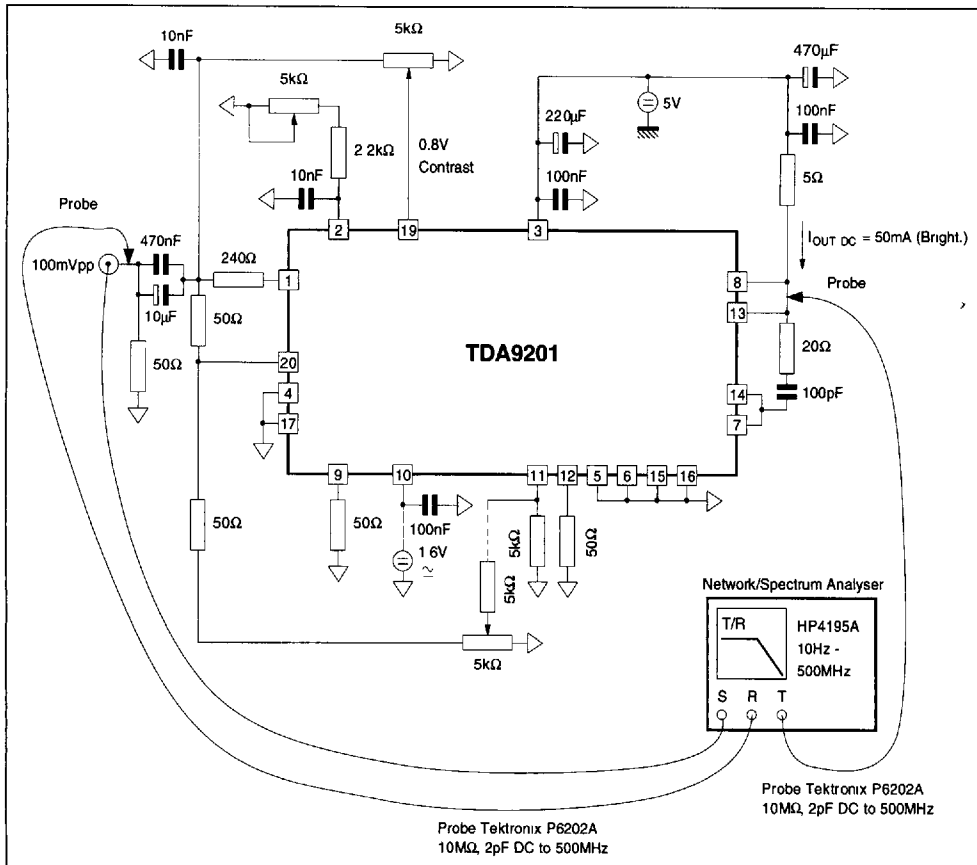


Figure 3 : Typical Gain versus Contrast Voltage Characteristic

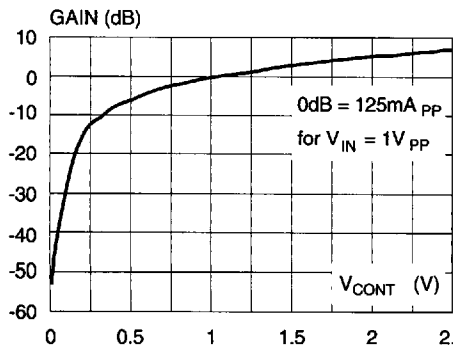


Figure 4 : V<sub>preset</sub> versus Contrast Voltage for 0dB

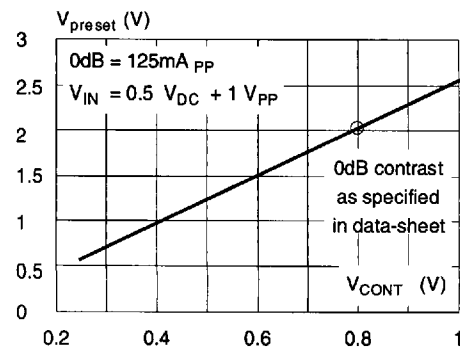
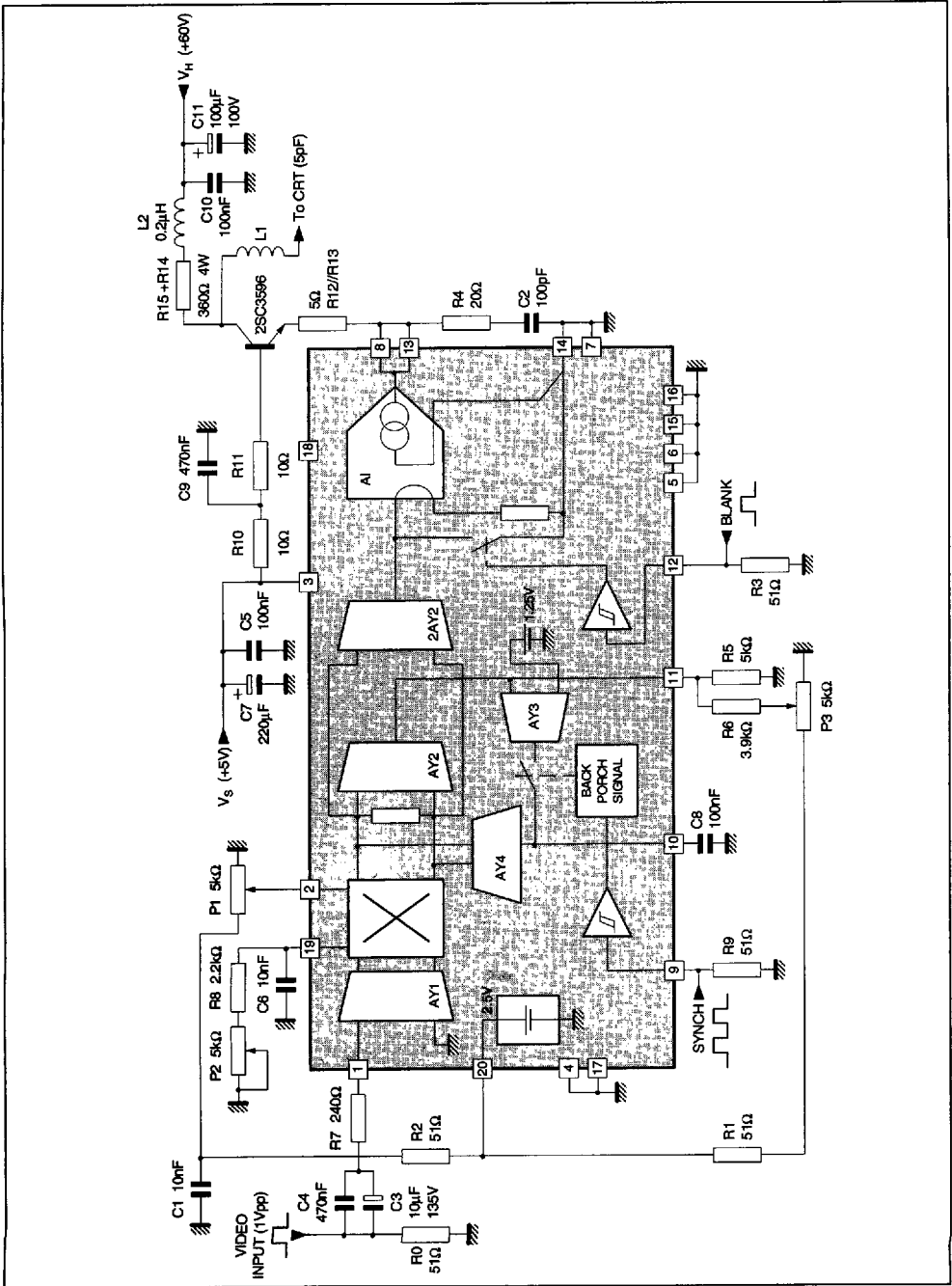
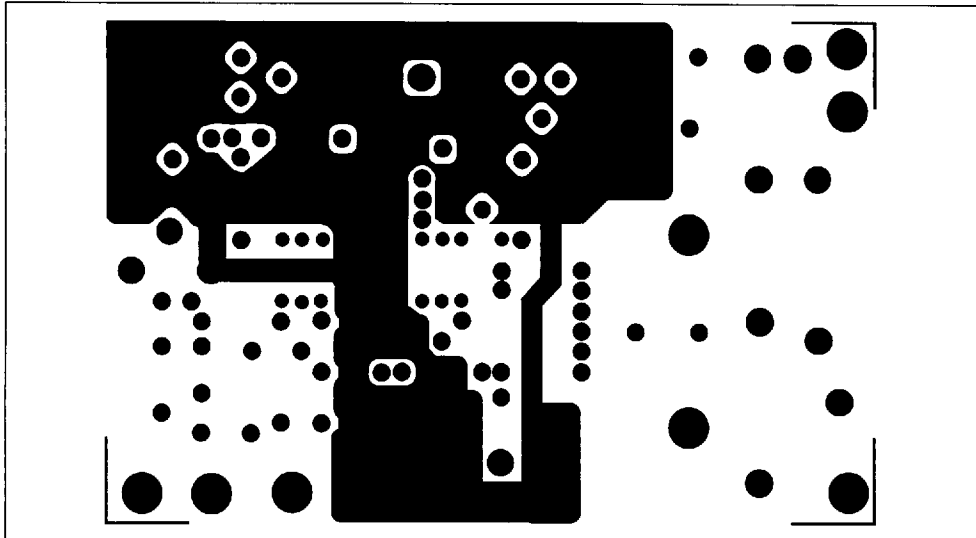


Figure 5 : Typical Application Circuit



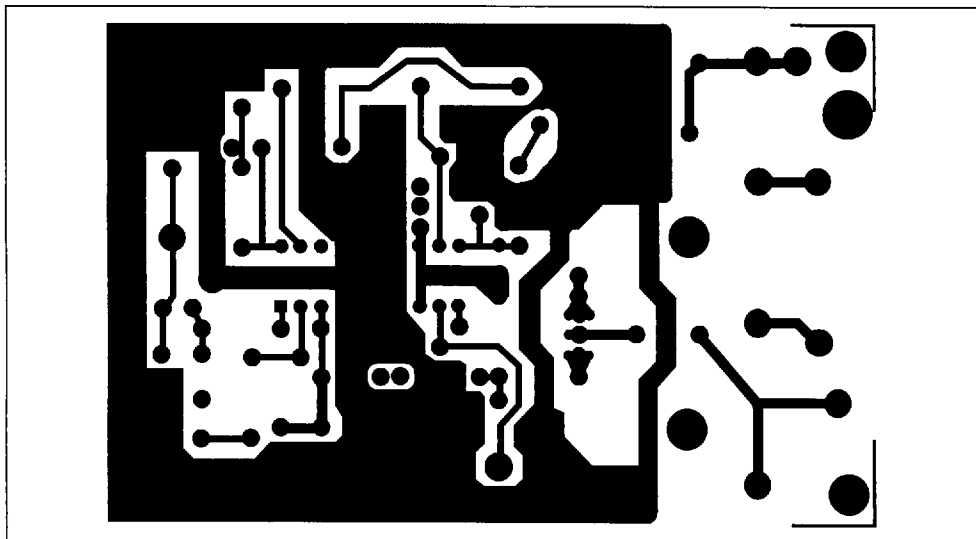
8201-07 EP8

Figure 6 : Components Side



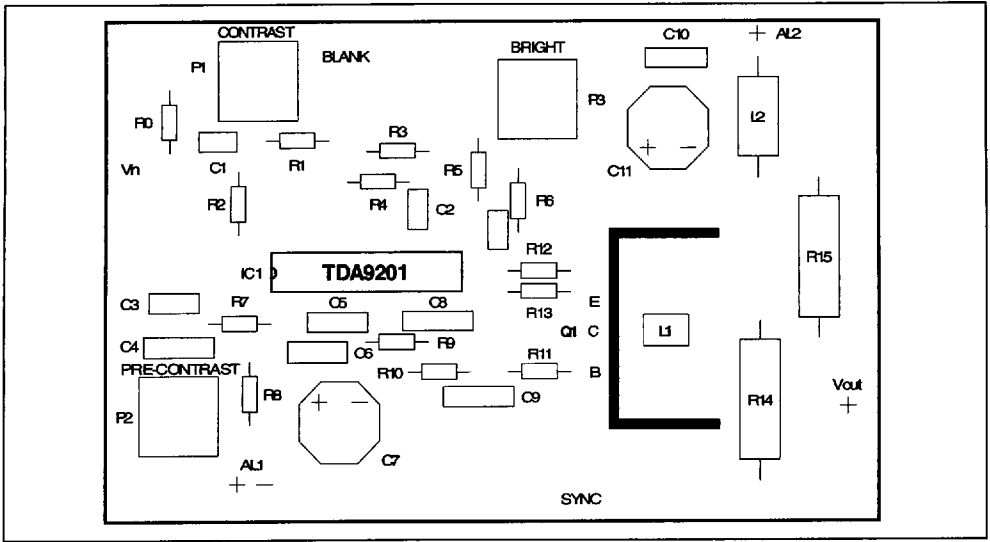
8201-08 EPS

Figure 7 : Solder Side



8201-09 EPS

Figure 8 : Assy-plan



9201 10 EPS

COMPONENT LIST

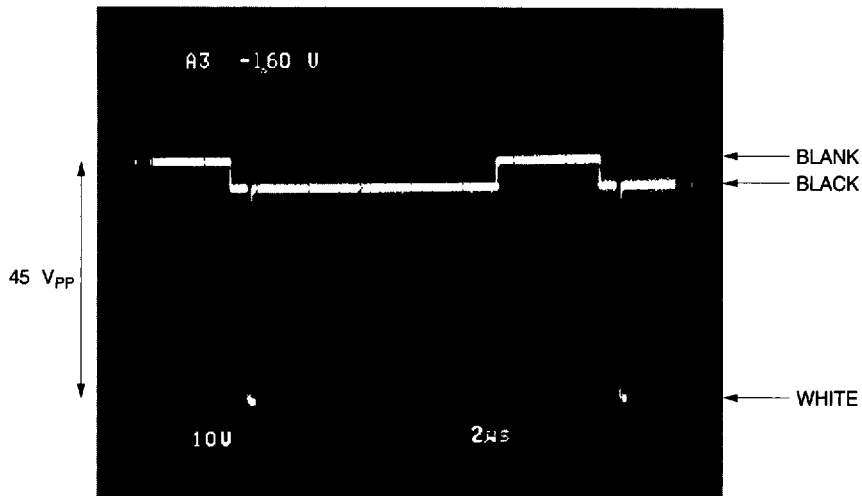
Component	Value
R0, R1, R2, R3, R9	51Ω
R4	20Ω
R5, R6	5.1kΩ
R7	240Ω
R8	2.2kΩ
R10, R11, R12, R13	10Ω
R14, R15	180Ω, 3W
P1, P2, P3	5kΩ
C1, C8	10nF
C2	100pF

Component	Value
C3	10μF/35V Tantale
C4, C9	470nF
C5, C8, C10	100nF
C7	220μF/25V
C11	100μF/100V
L1	Strap
L2	0.2μH
Q1	2SC3596E
IC1	TDA9201

9201-08 TBL

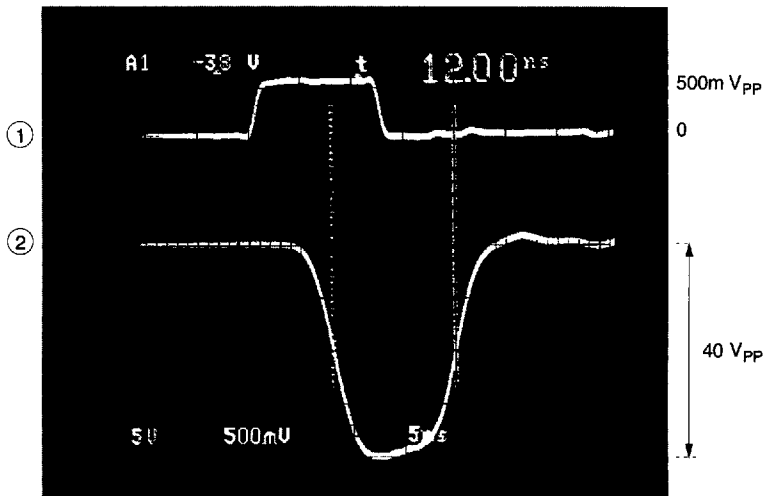


Figure 9 : Output Signal on CRT (bright. and cont.) White Vertical Line on Screen



9201 11.EPS

Figure 10 : 1. Input Video (500mV<sub>PP</sub>)  
2. Output to CRT 40V<sub>PP</sub>-12ns (one pixel), 150mA, pixel rate 83MHz, BW ≅ 120MHz



9201 12.EPS

Figure 11 : Fall Time (see test conditions, Figure 13)

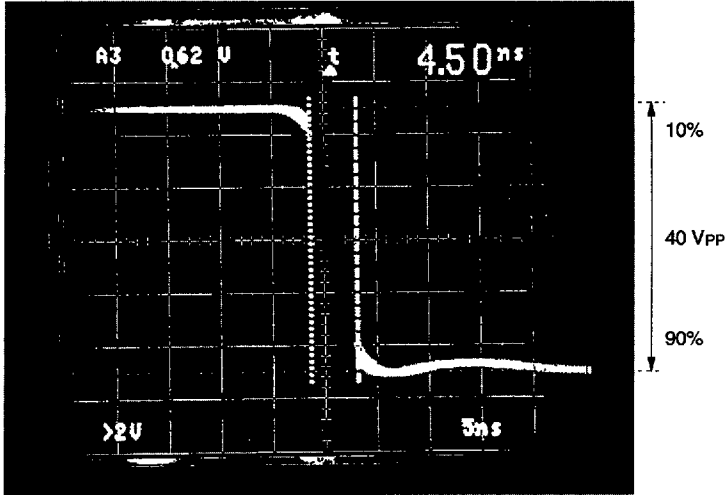
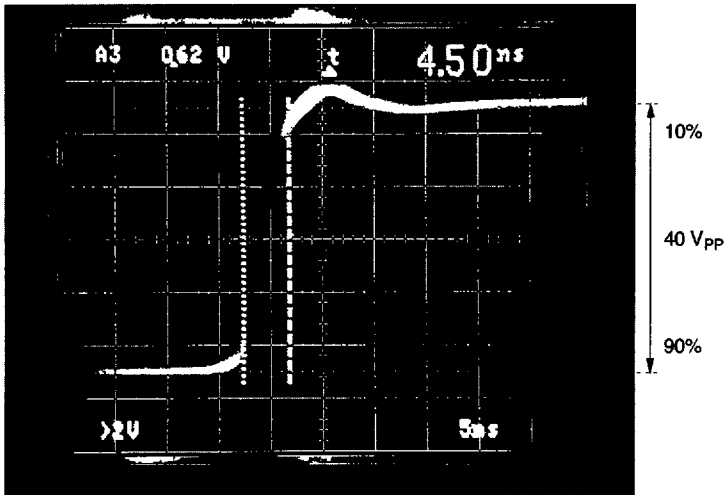


Figure 12 : Rise Time (see test conditions, Figure 13)



9201-13 EFS

9201-14 EFS

Figure 13 : Measurement Conditions

