

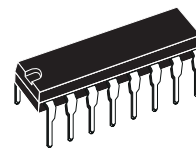

**TEA3717**

## STEPPER MOTOR DRIVER

- HALF-STEP AND FULL-STEP MODE
- BIPOLAR DRIVE OF STEPPER MOTOR FOR MAXIMUM MOTOR PERFORMANCE
- BUILT-IN PROTECTION DIODES
- WIDE RANGE OF CURRENT CONTROL 5 TO 1000 mA
- WIDE VOLTAGE RANGE 10 TO 45 V
- DESIGNED FOR UNSTABILIZED MOTOR SUPPLY VOLTAGE
- CURRENT LEVELS CAN BE SELECTED IN STEPS OR VARIED CONTINUOUSLY



**POWERDIP 12 + 2 + 2**

**ORDERING NUMBER : TEA3717DP**

### DESCRIPTION

The TEA3717 is a bipolar monolithic integrated circuit intended to control and drive the current in one winding of a bipolar stepper motor. The circuit consists of an LS-TTL compatible logic input, a current sensor, a monostable and an output stage with built-in protection diodes. Two TEA3717 and a few external components form a complete control and drive unit for LS-TTL or microprocessor-controlled stepper motor systems.

### PIN CONNECTION (top view)

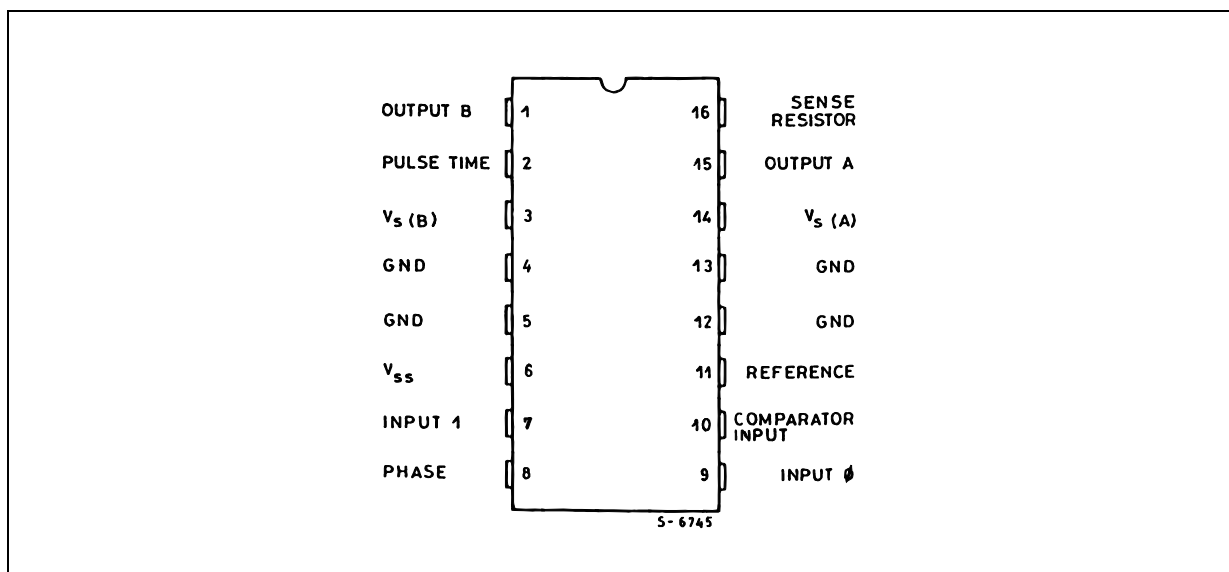

**SCHEMATIC DIAGRAM**

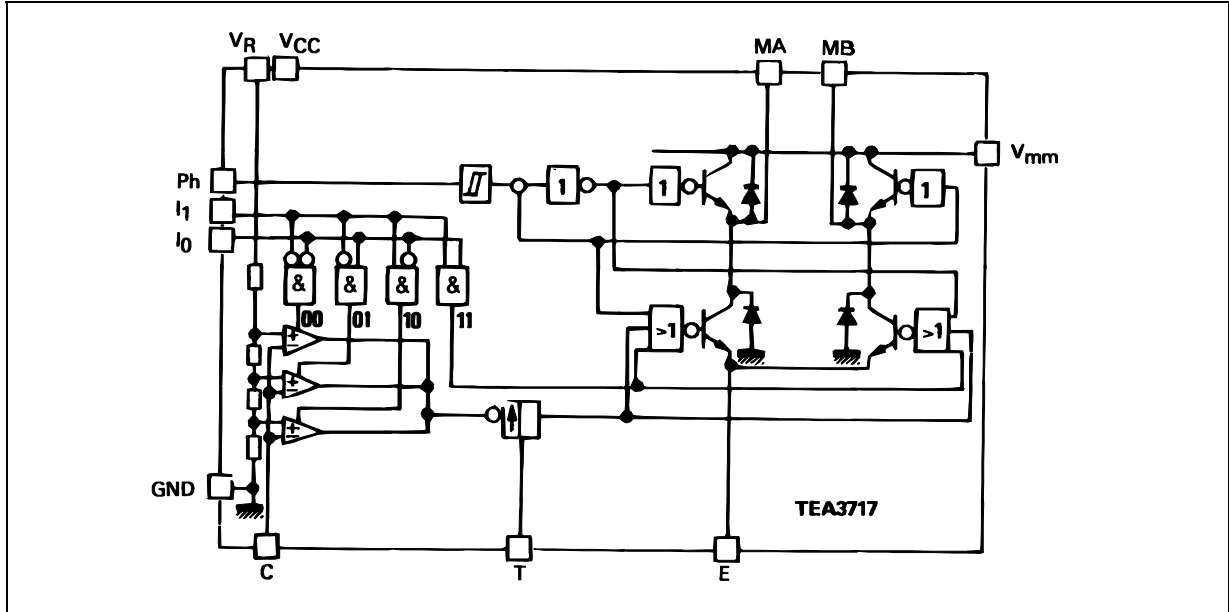

**ABSOLUTE MAXIMUM RATINGS**

Symbol	Parameter	Value	Unit
$V_{mm}$	Power Supply Voltage (pins 14, 3)	45	V
$V_{CC}$	Logic Supply Voltage (pin 6)	7	V
$V_{in}$ $V_{in}$ $V_V$	Input Voltage Logic Inputs Analog Inputs Reference Input	- 0.5 to 6 $V_{CC}$ 15	V
$I_{in}$ $I_{in}$	Input Current Logic Inputs Analog Inputs	- 10 - 10	mA
$I_o$	Output Current	$\pm 1$	A
$T_j$	Junction Temperature	+ 150	$^{\circ}C$
$T_{stg}$	Storage Temperature Range	- 55 to + 150	$^{\circ}C$
$T_{oper}$	Operating Ambient Temperature Range	0 to + 70	$^{\circ}C$

**THERMAL DATA**

Symbol	Parameter	Value	Unit
$R_{th(j-c)}$	Maximum Junction-pins Thermal Resistance	11	$^{\circ}C/W$
$R_{th(j-a)}$	Maximum Junction-ambient Thermal Resistance	45*	$^{\circ}C/W$

\* Soldered on a 35 mm thick 20 cm<sup>3</sup> PC board copper area

**RECOMMENDED OPERATING CONDITIONS**

Symbol	Parameter	Min.	Typ.	Max.	Unit
$V_{CC}$	Supply Voltage	4.75	5	5.25	V
$V_{mm}$	Supply Voltage	10	-	40	V
$I_o$	Output Current	0.020	-	0.8	A
$T_{amb}$	Ambient Temperature	0	-	70	$^{\circ}C$
$t_r$	Rise Time, Logic Inputs	-	-	3	$\mu s$
$t_f$	Fall Time, Logic Inputs	-	-	3	$\mu s$

**ELECTRICAL CHARACTERISTICS**

$V_{CC} = 5V, \pm 5\%, V_{mm} = +10V \text{ to } +40V, T_{amb} = 0^{\circ}C \text{ to } +70^{\circ}C$  (unless otherwise specified)

Symbol	Parameter	Min.	Typ.	Max.	Unit
$I_{CC}$	Supply Current	-	-	25	mA
$V_{IH}$	High Level Input Voltage - Logic Inputs	2.0	-	-	V
$V_{IL}$	Low Level Input Voltage - Logic Inputs	-	-	0.8	V
$I_{IH}$	High Level Input Current - Logic Input ( $V_I = +2.4V$ )	-	-	20	$\mu A$
$I_{IL}$	Low Level Input Current - Logic Inputs ( $V_I = +0.4V$ )	-0.4	-	-	mA
$V_{CH}$ $V_{CM}$ $V_{CL}$	Comparator Threshold Voltage ( $V_R = +5.0V$ ), $I_0 = 0, I_1 = 0$ $I_0 = 1, I_1 = 0$ $I_0 = 0, I_1 = 1$	390 230 65	420 250 80	440 270 90	mV
$I_{CO}$	Comparator Input Current	-20	-	+20	$\mu A$
$I_{off}$	Output Leakage Current ( $I_0 = 1, I_1 = 1$ ) $T_{amb} = +25^{\circ}C$ $T_{amb} = +70^{\circ}C, V_S = 40V, V_{SS} = 5V$	- -	- 100	100 200	$\mu A$
$V_{sat}$	Total Saturation Voltage Drop ( $I_0 = 500mA$ )	-	-	4.0	V
$P_{tot}$	Total Power Dissipation $I_0 = 500mA, f_s = 30kHz$ $I_0 = 800mA, f_s = 30kHz$	- -	1.8 3.7	2.3 -	W
$t_{off}$	Cut off Time (see figure 1 and 2, $V_{mm} = +10V, t_{on} \geq 5\mu s$ )	25	30	35	$\mu s$
$t_d$	Turn off Delay (see figure 1 and 2, $T_{amb} = +25^{\circ}C, dV_C/dt \geq 50mV/\mu s$ )	-	1.6	-	$\mu s$

Figure 1 (see note)

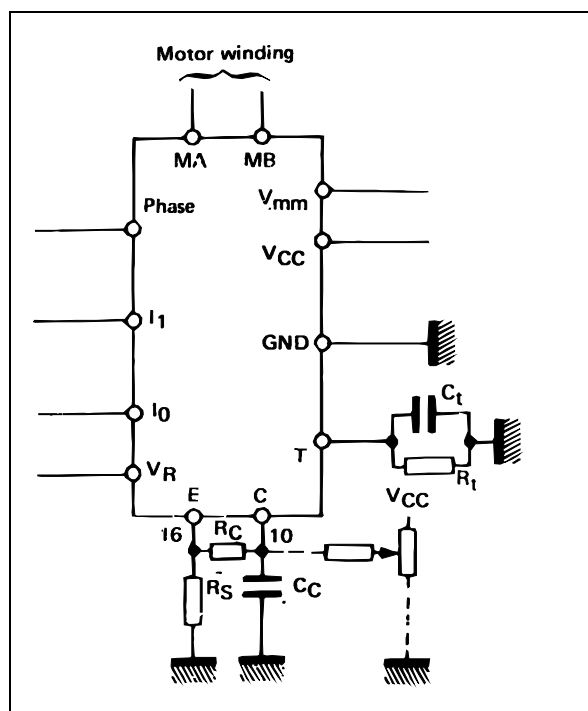
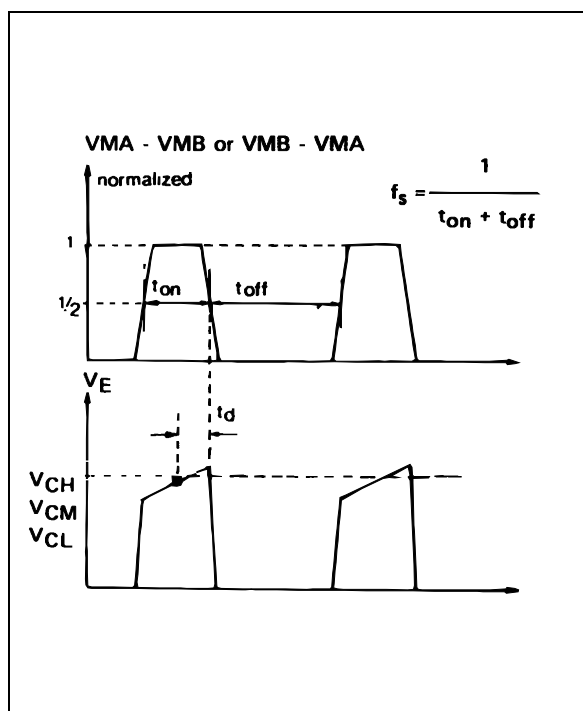

Figure 2.



## FUNCTIONAL DESCRIPTION

The circuit is intended to drive a bipolar constant current through one motor winding. The constant current is generated through switch mode regulation.

There is a choice of three different current levels with the two logic inputs  $I_0$  and  $I_1$ . The current can also be switched off completely.

## INPUT LOGIC

If any of the logic inputs is left open, the circuit will treat it as a high level input.

$I_0$	$I_1$	Current Level
H	H	No Current
L	H	Low Current
H	L	Medium Current
L	L	Maximum Current

**PHASE** – This input determines the direction of current flow in the winding, depending on the motor connections. The signal is fed through a Schmidt-trigger for noise immunity, and through a time delay in order to guarantee that no short-circuit occurs in the output stage during phase-shift. High level on the PHASE-input causes the motor current flow from  $M_A$  through the winding to  $M_B$ .

$I_0$  and  $I_1$  – The current level in the motor winding is selected with these inputs. The values of the different current levels are determined by the reference voltage  $V_R$  together with the value of the sensing resistor  $R_S$ .

## CURRENT SENSOR

This part contains a current sensing resistor ( $R_S$ ), a low pass filter ( $R_C$ ,  $C_C$ ) and three comparators. Only one comparator is active at a time. It is activated by the input logic according to the current level chosen with signals  $I_0$  and  $I_1$ . The motor current flows through the sensing resistor  $R_S$ . When the current has increased so that the voltage across  $R_S$  becomes higher than the reference voltage on the

**Note :**  $R_S = 1 \Omega$ , inductance free  
 $R_C = 1 \text{ k}\Omega$   
 $C_C = 820 \text{ pF}$ , ceramic  
 $R_t = 56 \text{ k}\Omega$

other comparator input, the comparator output goes high, which triggers the pulse generator and its output goes high during a fixed pulse time ( $t_{off}$ ), thus switching off the power feed to the motor winding, and causing the motor current to decrease during  $t_{off}$ .

## SINGLE-PULSE GENERATOR

The pulse generator is a monostable triggered on the positive going edge of the comparator output. The monostable output is high during the pulse time,  $t_{off}$ , which is determined by the timing components  $R_t$  and  $C_t$ .

$$t_{off} = 0.69 \cdot R_t \cdot C_t$$

The single pulse switches off the power feed to the motor winding, causing the winding current to decrease during  $t_{off}$ .

If a new trigger signal should occur during  $t_{off}$ , it is ignored.

## OUTPUT STAGE

The output stage contains four Darlington transistors and four diodes, connected in an H-bridge. The two sinking transistors are used to switch the power supplied to the motor winding, thus driving a constant current through the winding.

It should be noted however, that it is not permitted to short circuit the outputs.

$V_{CC}$ ,  $V_{mm}$ ,  $V_R$

The circuit will stand any order of turn-on or turn-off of the supply voltages  $V_{SS}$  and  $V_S$ . Normal  $dV/dt$  values are then assumed.

Preferably,  $V_R$  should be tracking  $V_{CC}$  during power-on and power-off.

## ANALOG CONTROL

The current levels can be varied continuously either if  $V_R$  is varied or with a circuit varying the voltage fed into the comparator terminal (see fig.1).

Figure 3

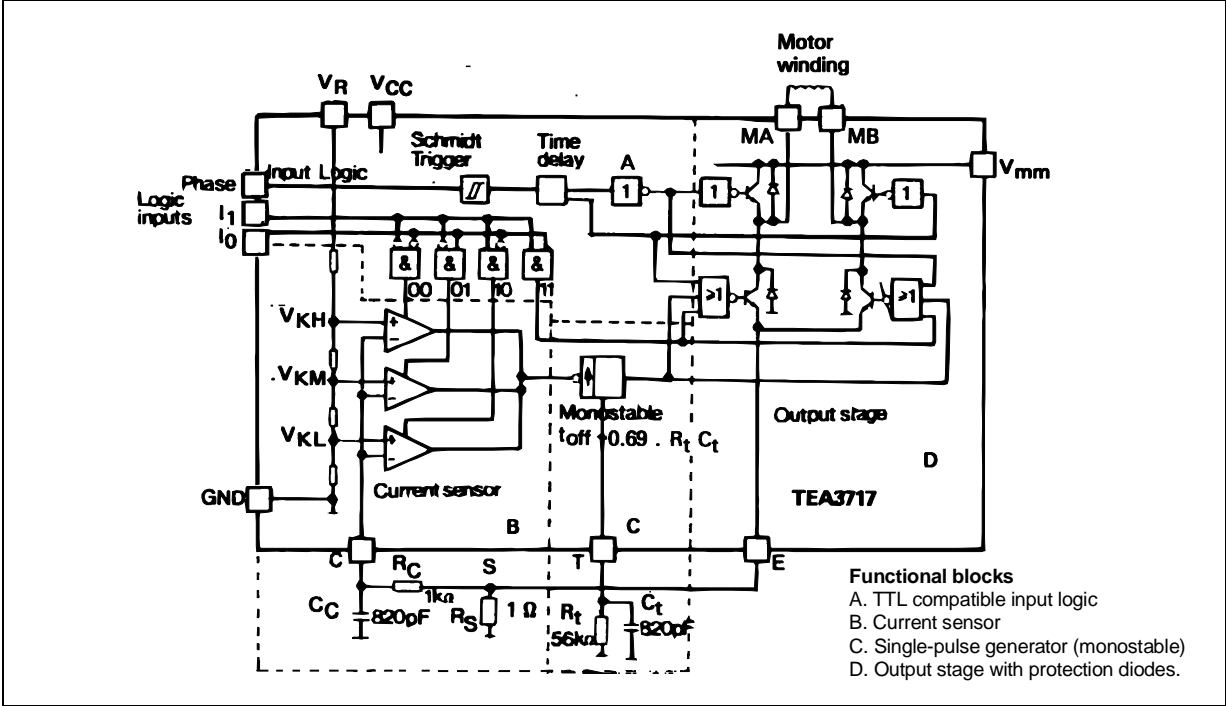

Figure 4 : Typical Sink Saturation Voltage versus Output Current

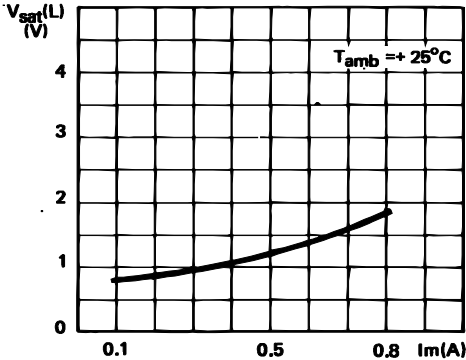

Figure 5 : Typical Source Saturation Voltage versus Output Current

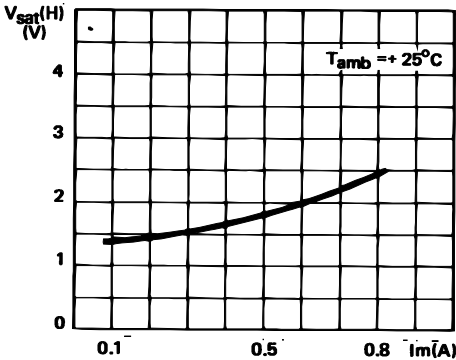
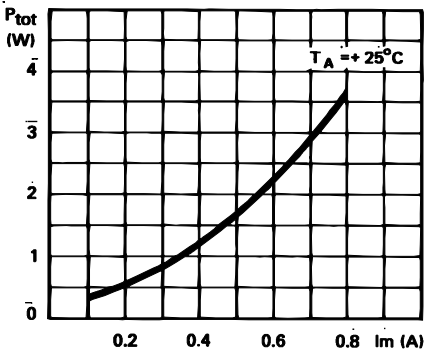

Figure 6 : Typical Power Losses versus Output Current



TYPICAL APPLICATION

Figure 7 : Serial Printer Carriage Drive.

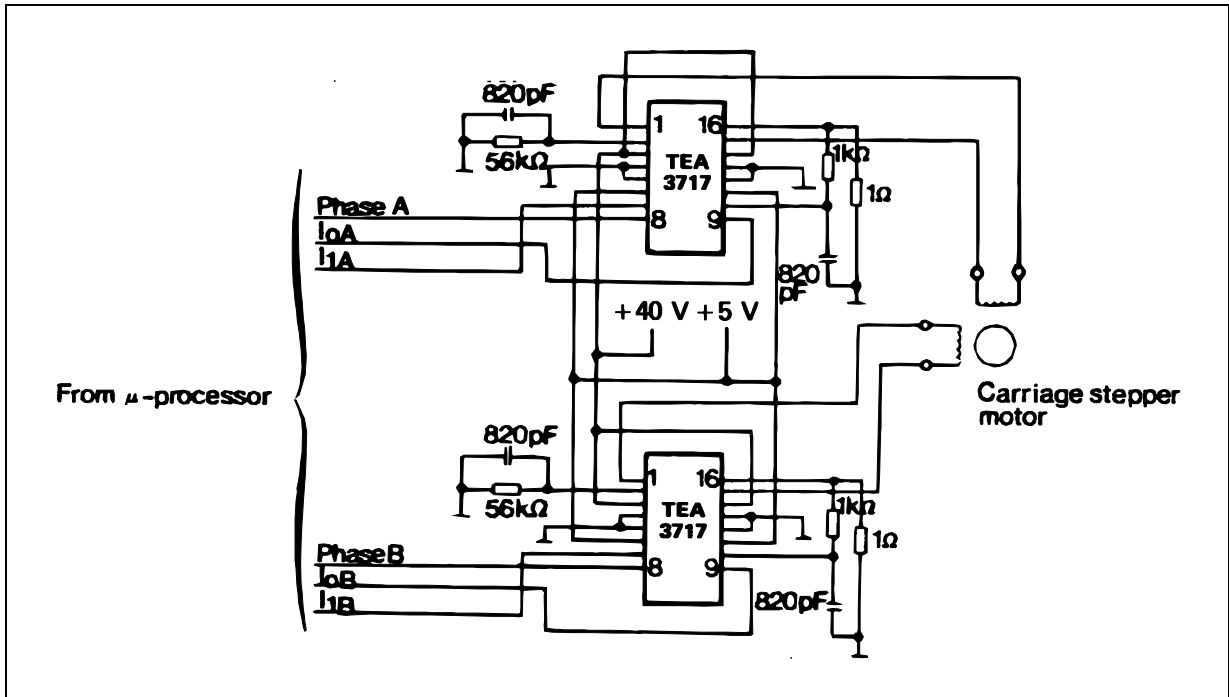
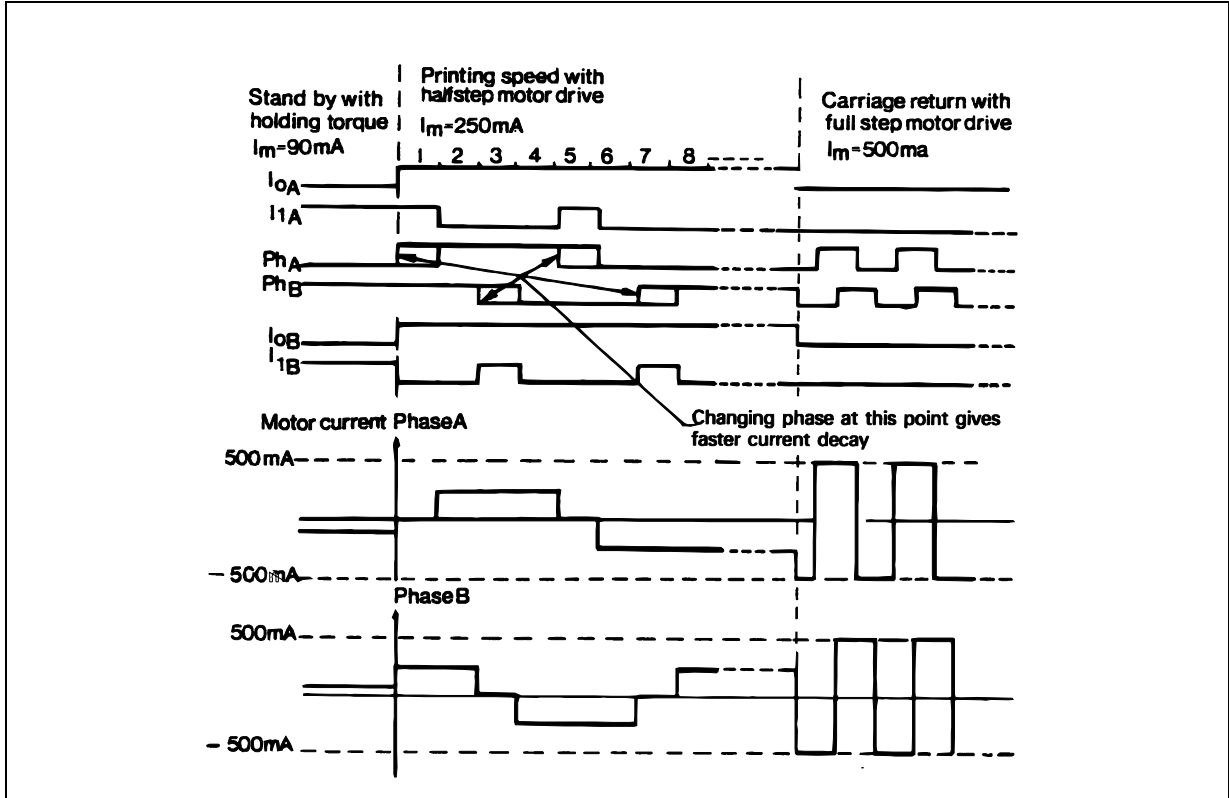
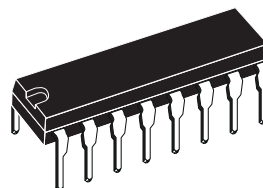

Figure 8 : Principal Operating Sequence.



DIM.	mm			inch		
	MIN.	TYP.	MAX.	MIN.	TYP.	MAX.
a1	0.51			0.020		
B	0.85		1.40	0.033		0.055
b		0.50			0.020	
b1	0.38		0.50	0.015		0.020
D			20.0			0.787
E		8.80			0.346	
e		2.54			0.100	
e3		17.78			0.700	
F			7.10			0.280
I			5.10			0.201
L		3.30			0.130	
Z			1.27			0.050

## OUTLINE AND MECHANICAL DATA



**Powerdip 16**

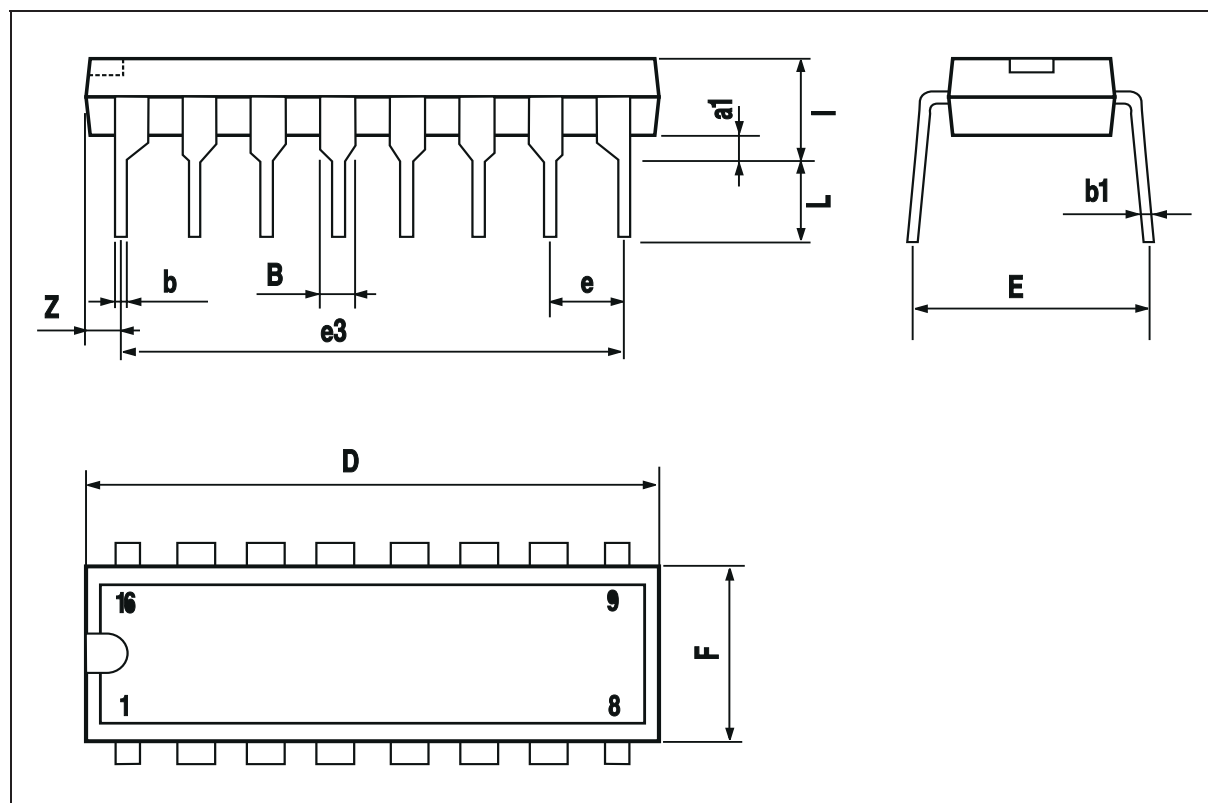

Information furnished is believed to be accurate and reliable. However, STMicroelectronics assumes no responsibility for the consequences of use of such information nor for any infringement of patents or other rights of third parties which may result from its use. No license is granted by implication or otherwise under any patent or patent rights of STMicroelectronics. Specification mentioned in this publication are subject to change without notice. This publication supersedes and replaces all information previously supplied. STMicroelectronics products are not authorized for use as critical components in life support devices or systems without express written approval of STMicroelectronics.

The ST logo is a registered trademark of STMicroelectronics  
© 2003 STMicroelectronics – Printed in Italy – All Rights Reserved  
STMicroelectronics GROUP OF COMPANIES

Australia - Brazil - Canada - China - Finland - France - Germany - Hong Kong - India - Israel - Italy - Japan - Malaysia - Malta - Morocco - Singapore - Spain - Sweden - Switzerland - United Kingdom - United States.  
<http://www.st.com>