

Features

- Switch mode power supplies for DIN-rail mounting
- 6 power ranges with 2, 3, 6, 12, 20 and 24 A output current (24 VDC models)
- Selectable 115/ 230 VAC input
- Very low ripple and noise
- EMI complies with EN50081-2 and EN50082-2
- Conducted EMI to EN55011 class B
- For system operation available with built-in functions:
 - RED:** Redundancy module for N+1 systems with true current sharing
 - SIG:** Signal module with AC-Power-fail, Power Good Signal and external ON/OFF control
 - UDS:** DC-UPS module for uninterruptible battery backed-up power systems
- Worldwide Safety Approvals
- Easy snap-on mounting on DIN-rails or chassis mounting
- 3 Year Product Warranty



The switching power supplies of the TIS series have been particularly designed for applications in industrial process control systems and machine tools. Excellent specifications and high immunity against electrical disturbances guarantee reliable power for sensitive loads in rugged industrial environments. With help of optional function modules specific requirements for system applications can be easily realized with a standard model. With the UDS module the power supplies can be extended to a perfect DC-UPS with automatic battery-backup. This function is very often required in applications where a time delayed shutdown of a system is necessary. To monitor and control the power supply a signal module can be installed. For parallel operation with active power sharing a redundancy option is available. This flexibility makes the TIS series power supplies a cost effective solution for many industrial applications.

Models

Ordercode (includes terminal plugs)	Input Voltage nom.	Output Power max.	Output Voltage nom.	Output Current max.
TIS 50-112 TIS 50-124	115 – 240 VAC universal input	50 W	12 VDC 24 VDC	3.5 A 2.0 A
TIS 75-112 TIS 75-124 TIS 75-148	115 / 230 VAC selectable	75 W	12 VDC 24 VDC 48 VDC	6.0 A 3.0 A 1.5 A
*TIS 150-124 (P) *TIS 150-148 (P)	115 / 230 VAC selectable	150 W	24 VDC 48 VDC	6.0 A 3.0 A
*TIS 300-124 (P) *TIS 300-148 (P) TIS 300-172	115 / 230 VAC selectable	300 W	24 VDC 48 VDC 72 VDC	12 A 6.0 A 4.2 A
TIS 500-124-115 TIS 500-124-230	115 VAC 230 VAC	500 W 500 W	24 VDC 24 VDC	20 A 20 A
TIS 600-124 TIS 600-128 TIS 600-148 TIS 600-172	115 / 230 VAC selectable	600 W	24 VDC 28 VDC 48 VDC 72 VDC	24 A 22 A 12 A 8.5 A

*If compliance to EN 61000-3-2 (PFHC – Power Factor Harmonic Current) is required, option **P** is available for these models

Input Specifications

Input voltage range	- TIS 50	93 – 264 VAC	
	- TIS 75, 150, 300, 600	93 – 132 VAC / 187 – 264 VAC	
	- TIS 500-124-230	187 – 264 VAC	
	- TIS 500-124-115	93 – 132 VAC	
Input frequency		47 – 63 Hz	
Input current at full load (typ.)		115 VAC	230 VAC
	- TIS 50	1.2 A	0.7 A
	- TIS 75	1.7 A	0.9 A
	- TIS 150	3.0 A	1.7 A
	- TIS 300	5.4 A	3.3 A
	- TIS 500	9.5 A	5.5 A
	- TIS 600	10.5 A	6.4 A
Recommended circuit breaker, characteristic C or fuse, slow blow typ	- TIS 50	5.0 A	
	- TIS 75	5.0 A	
	- TIS 150	10.0 A	
	- TIS 300	15.0 A	
	- TIS 500	15.0 A	
	- TIS 600	20.0 A	

Output Specifications

Output voltage adj. range	- 12 VDC models	12 – 14 VDC	
	- 24 VDC models	24 – 28 VDC	
	- 28 VDC models	28 – 32 VDC	
	- 48 VDC models	48 – 52 VDC (48 – 55 VDC on request))	
	- 72 VDC models	60 – 76 VDC	
Regulation – Input variation		± 0.2 %	
	- Load variation (10–90%)	- TIS 50, TIS 75, TIS 150	± 1.0 %
		- TIS 300, TIS 500, TIS 600	± 0.3 % (± 2.0 % in parallel operation)
Ripple and Noise (20MHz Bandwidth)		< 50 mV pk-pk	
Electronic short circuit protection		current limitation at 110 % typ. (constant current, automatic restart)	
Overvoltage protection, triggerpoint at		140 % typ. Vout nom.	
Hold-up time		115 VAC	230 VAC
	- TIS 50 ... TIS 300	min. 25 ms	min. 30 ms
	- TIS 500	min. 20 ms	min. 40 ms
	- TIS 600	min. 15 ms	min. 25 ms

All specifications valid at nominal input voltage, full load and +25°C after warm-up time unless otherwise stated.

General Specifications

Temperature ranges	– Operating (ambient temp.) – Derating above 50 °C (122°F) – Storage (non operating)	– 25 °C...+70 °C (– 13°F...+185°F) 2% / K – 25 °C...+85 °C (– 13°F...+185°F)
Humidity (non condensing)		95 % rel H max.
Pollution degree		2
Temperature coefficient		0.02 % / K
Switching frequency		80 kHz typ. (Pulswidth modulation)
Efficiency	– TIS 50 ... TIS 300 – TIS 500 – TIS 600	85 % typ. 90 % typ. 90 % typ.
Isolation		according to IEC/ EN 60950, UL 60950, UL 508
Reliability, calculated MTBF (MIL-HDBK-217 E)	– TIS 50 /75 – TIS 150 /300 – TIS 500 /600	450000 h @ +25°C/ 420000 h @ +25°C 420000 h @ +25°C/ 360000 h @ +25°C 340000 h @ +25°C/ 300000 h @ +25°C
Safety standards		IEC/ EN 60950 (SELV, except 72 VDC models), UL/cUL 60950, UL 508, UL/cUL 1604
Safety approvals (TIS 500 pending)		UL/cUL 60950 recognized, File E181381 UL/cUL 508 listed, File E210002 (tested by UL to surrounding temperature of 40°C) *UL/cUL 1604 listed, File E213613 (Class I, Division 2, Groups A, B, C and D hazardous locations) CB-Report as per IEC 60950
*basic models except TIS50 & TIS500		
Electromagnetic compatibility (EMC), Emissions	– Conducted RI suppression on input – Radiated RI suppression – Harmonic current emissions (for -P models)	EN 50081-1 / EN 50081-2 EN 55011 class B, EN 55022 class B, FCC part 15, level B EN 55011 class A, EN 55022 class A, FCC part 15, level A EN 6100-3-2, class A
Electromagnetic compatibility (EMC), Immunity	– Electrostatic discharge (ESD) – Radiated RF field immunity – Electrical fast transient / burst immunity – Surge immunity – Immunity to conducted RF disturbances – Power frequency field immunity	EN 50082-2 IEC / EN 61000-4-2 4 kV / 8 kV IEC / EN 61000-4-3 10 V / m IEC / EN 61000-4-4 2 kV IEC / EN 61000-4-5 2 kV / 4 kV IEC / EN 61000-4-6 10 V IEC / EN 61000-4-8 30 A / m
Safety class		Degree of electrical protection 1 (IEC 536)
Case protection		IP 20 (IEC 529)
Environment	– Vibration – Shock	IEC 60068-2-6;1 gn, 200 sweeps, each axis IEC 60068-2-27; 15 gn, 11 ms, each axis
Enclosure material		Aluminium (chassis) / zinc plated steel (cover)
Mounting (snap-on with selflocking spring)		for 35 mm DIN-rails as per EN 50022
Connection		Plugable screw terminals (plugs included) (TIS 600: screw terminal blocks)

All specifications valid at nominal input voltage, full load and +25°C after warm-up time unless otherwise stated.

Power Supplies with Redundancy Function

With this option a parallel operation of up to 5 units is possible. Decoupling diodes and current share lines allow to build true N +1 redundant systems with active current sharing for all units. This function also includes an alarm relay to signal a single unit failure.
This option is available for TIS 150 W, TIS 300 W and TIS 600 W models. Please note: A combination with other options is not possible.

Models

Ordercode (includes terminal plugs)	Input Voltage	Output Power max.	Output Voltage nom.	Output Current max.
TIS 150-124 RED TIS 150-148 RED	115 / 230 VAC selectable	150 W	24 VDC 48 VDC	6.0 A 3.0 A
TIS 300-124 RED TIS 300-148 RED	115 / 230 VAC selectable	300 W	24 VDC 48 VDC	12 A 6.0 A
TIS 600-124 RED TIS 600-148 RED	115 / 230 VAC selectable	600 W	24 VDC 48 VDC	24 A 12 A

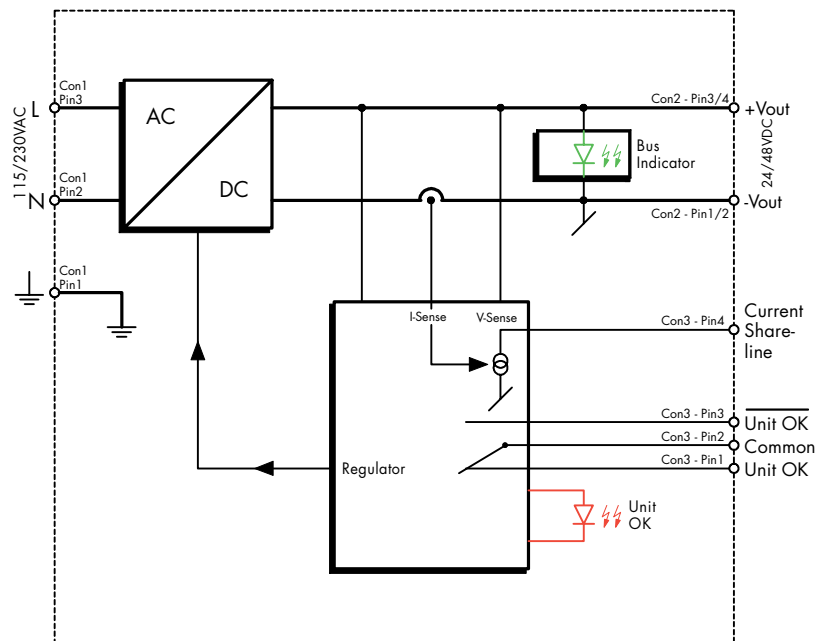

Specifications

Rating per relay contact

60 VDC /0.36 A max.

Download detailed instruction manual for RED option: http://tracopower.com/products/tis_red_manual.pdf

Specifications can be changed without notice

Power Supplies with Powerfail Functions

These models provide 3 functions required in many process control system applications:

- AC-Powerfail signal (relay contact)
- Power Good signal (relay contact)
- Remote ON/OFF

Models

Ordercode (includes terminal plugs)	Input Voltage	Output Power max.	Output Voltage nom.	Output Current max.
TIS 150-124 SIG TIS 150-148 SIG	115 / 230 VAC selectable	150 W	24 VDC 48 VDC	6.0 A 3.0 A
TIS 300-124 SIG TIS 300-148 SIG	115 / 230 VAC selectable	300 W	24 VDC 48 VDC	12 A 6.0 A
TIS 600-124 SIG TIS 600-148 SIG	115 / 230 VAC selectable	600 W	24 VDC 48 VDC	24 A 12 A

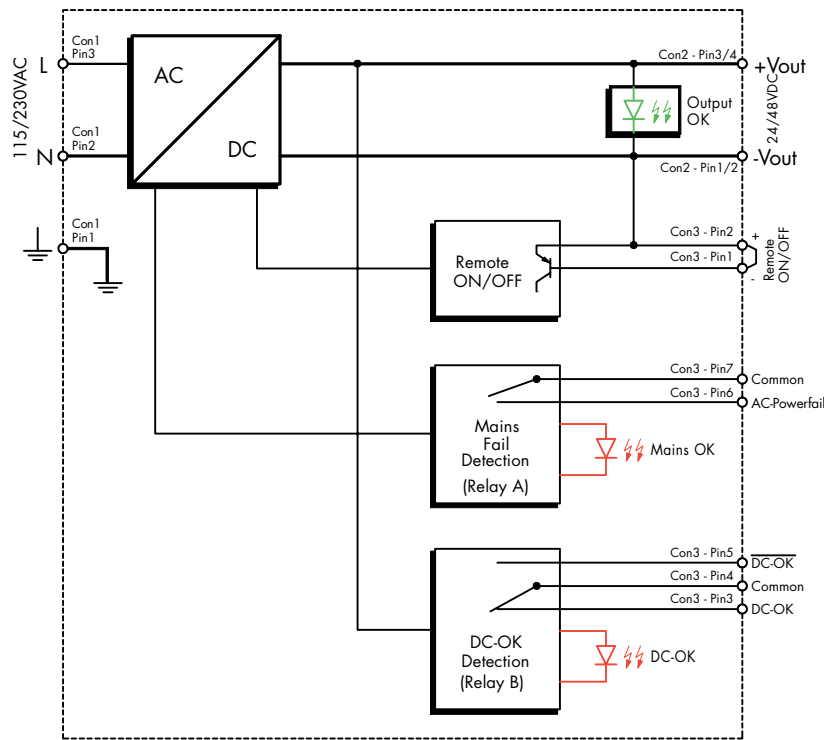

Specifications

Power Good signal trigger point	– Models with 24 Vout > 22.8 VDC ± 0.5 V – Models with 48 Vout > 45.6 VDC ± 1.0 V	relay B closed (pin 4 – pin 3) relay B closed (pin 4 – pin 3)
AC-Powerfail signal	Vin < 93 resp. < 187 VAC	relay A closed (pin 7 – pin 6)
Rating per relay contact	60 VDC / 0.36 A max.	
Remote ON / OFF	ON: short circuit con 3 pin 1 and pin 2 OFF: open circuit con 3 pin 1 and pin 2	

Download detailed instruction manual for SIG option: http://tracopower.com/products/tis_sig_manual.pdf

All specifications valid at nominal input voltage, full load and +25°C after warm-up time unless otherwise stated.

DC-UPS-System



In addition to the standard power supply function, these models include a professional battery management system to charge and monitor an external battery. In case of a power failure the battery is switched automatically and without any interruption to the DC-output. If mains power is available again, the battery is switched off. The hold-up time is limited only by battery capacity and load. Charge current and voltage can be adjusted to values as required by battery type. Power fail and low battery alarm signals

are available via two independent relay contacts. During normal operation the battery status is monitored by periodically loading the battery for short time. If a cell resistance is high, there is a relay alarm available. The battery is fully protected under any operational conditions. The power supply is short circuit protected even in battery-backup operation, however for safety reason the battery should be fused with a fast blow fuse. Battery mode can be activated by connection of Pin 7 and 8.

Complete external battery packs (3.2 Ah or 7 Ah standard) with lead batteries and circuit breaker are available (see page 8).

Models				
Ordercode (includes terminal plugs)	Input Voltage	Output Power max.	Output Voltage nom.	*Output Current max.
TIS 300-124 UDS	115 / 230 VAC selectable	300 W	24 VDC	12 A
TIS 600-124 UDS	115 / 230 VAC selectable	600 W	24 VDC	24 A

*reduce max. output current by battery charging current

All specifications valid at nominal input voltage, full load and +25°C after warm-up time unless otherwise stated.

DC-UPS-System

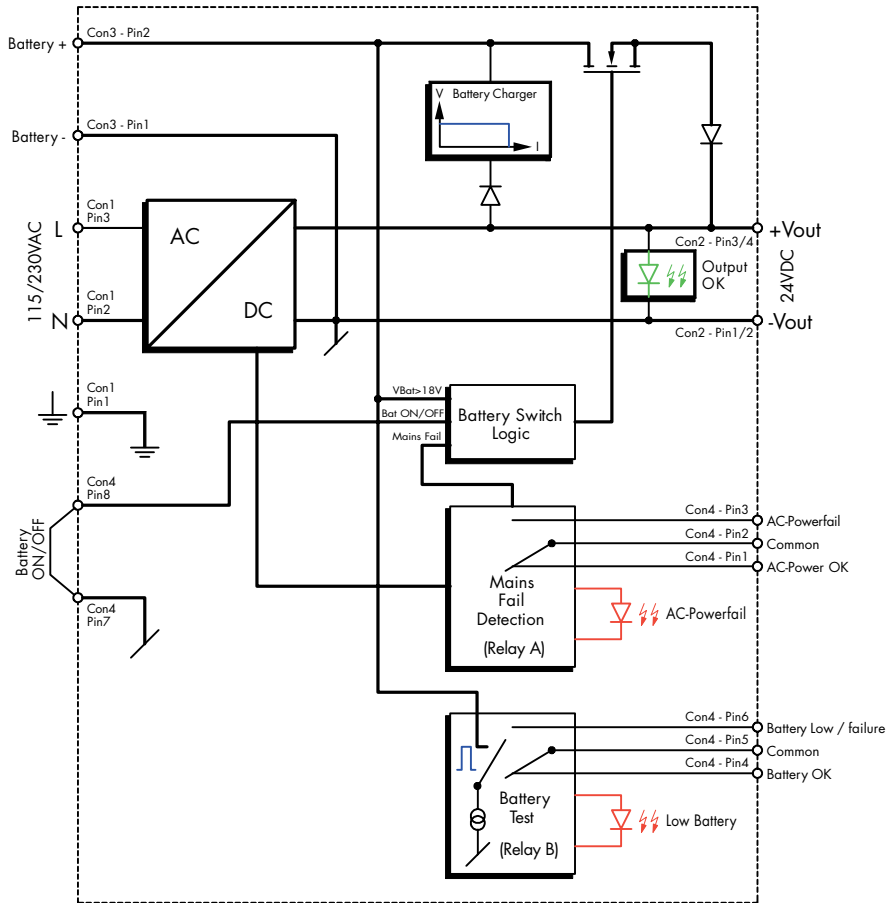

Specifications

Charging current (factory set)	- TIS 300-124 UDS	1.2 A
	- TIS 600-124 UDS	2.4 A
Adjustment range of charging current	- TIS 300-124 UDS	0.15...1.5 A
	- TIS 600-124 UDS	0.25...2.5 A
Holding current for charging battery at voltage 27.3 VDC		< 50 mA
Overload at short circuit during battery operation		system switches off
AC-Powerfail signal	Vin < 93 resp. < 187 VAC	relay A closed (pin 2 – pin 3)
Low battery signal	Battery voltage below 22 V	relay B closed (pin 5 – pin 6)
Rating per relay contact		60 VDC /0.36 A max.
During battery charge operation		output current reduction by 1.4 x battery charge current

Download detailed instruction manual for UDS option: http://tracopower.com/products/tis_uds_manual.pdf

All specifications valid at nominal input voltage, full load and +25°C after warm-up time unless otherwise stated.

Battery-Pack for DC-UPS Systems

The Battery Pack contains high quality, maintenance free lead-acid batteries with 3.2 Ah resp. 7.0 Ah capacity. The batteries are fixed together with a re-settable electronic fuse on a solid mounting frame. Together with power supply models TIS 300-124 UDS or TIS 600-124 UDS the battery pack provides a complete and reliable DC-UPS system. Backup time is depending on load current and battery capacity.

Models

Ordercode	Battery Voltage	Battery Capacity (25°C, 20h-rate)	Permissible Charge Current max.
TIS 24-32 AP	24 VDC	3.2 Ah	1.2 A
TIS 24-70 AP	24 VDC	7.0 Ah	2.4 A

Specifications

Max. charge voltage		27...27.6 VDC
Temperature coefficient		- 36mV /°C
Temperature range	- at charge operation - at load operation - Storage	- 15 °C...+50 °C - 20 °C...+60 °C - 20 °C...+60 °C
Average lifetime on standby operation at tA =20 °C		4...5 years
Cable length		1.0 m
Cable diameter	- TIS 24-32 AP - TIS 24-70 AP	2.5 mm ² (AWG 12) 4.0 mm ² (AWG 11)
Weight	- TIS 24-32 AP - TIS 24-70 AP	4.6 kg (10.1 lb) 5.9 kg (13.0 lb)
Recommended combinations (power supplies)	- TIS 24-32 AP - TIS 24-70 AP	TIS 300-124 UDS TIS 600-124 UDS

All specifications valid at nominal input voltage, full load and +25°C after warm-up time unless otherwise stated.

Outline Dimensions mm (inches)

TIS 50

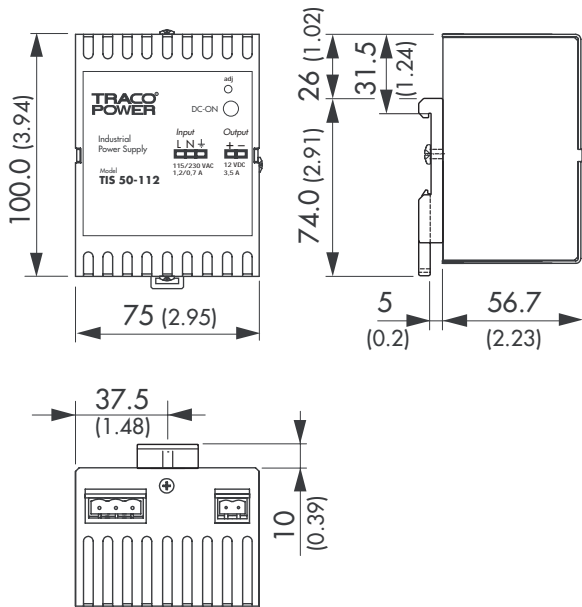

TIS 75

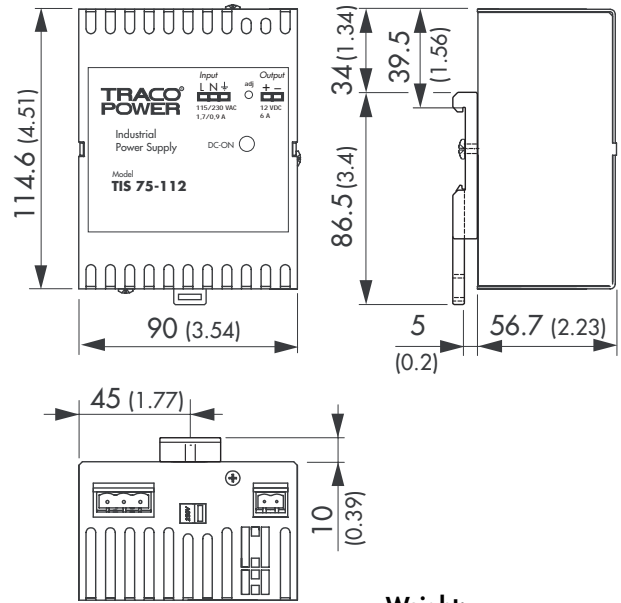

Weight:

TIS 50 0.41 kg (0.9 lb)

TIS 75 0.48 kg (1.06 lb)

TIS 150

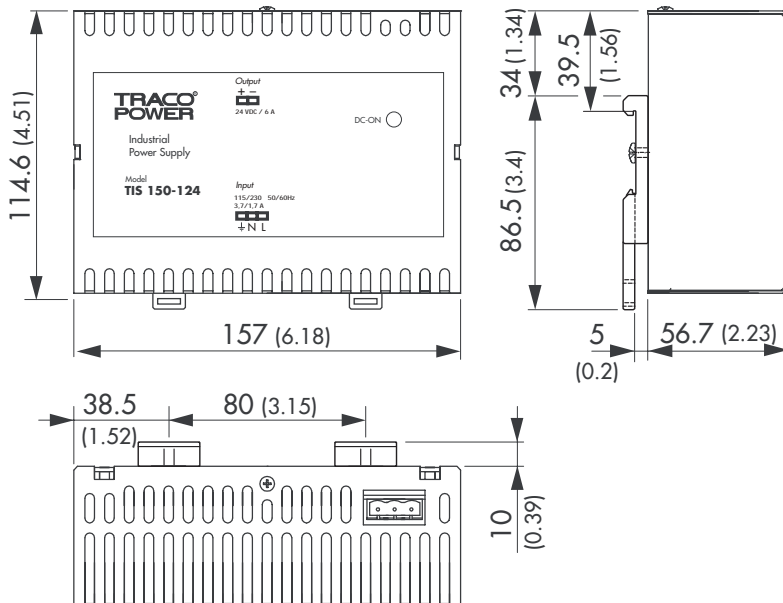

Weight:

TIS 150 0.80 kg (1.76 lb)

Outline Dimensions mm (inches)

TIS 300

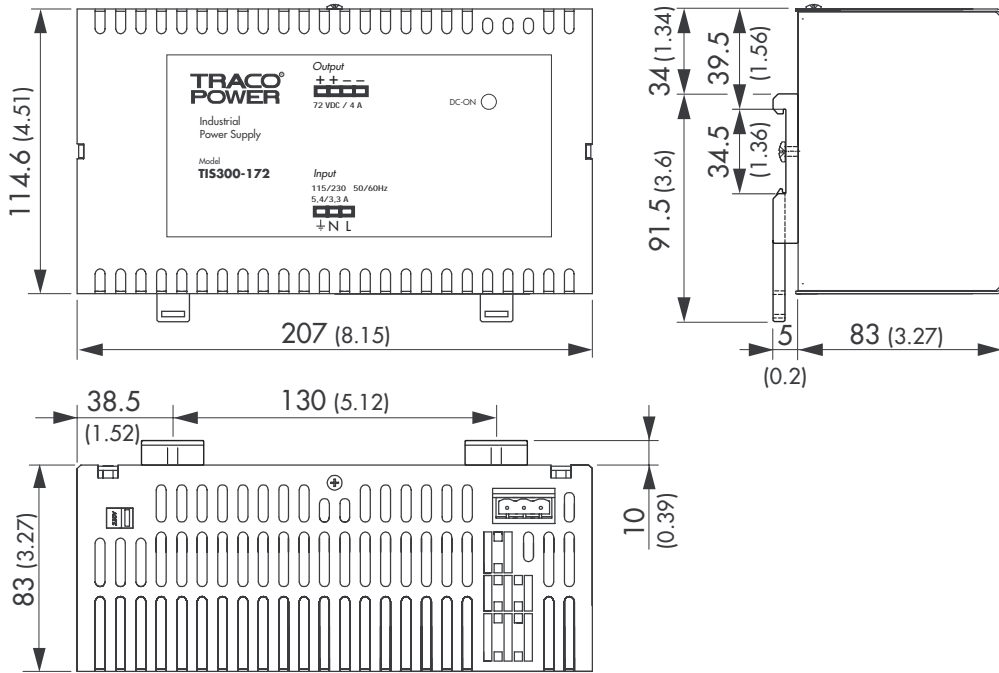

Weight:
TIS 300 1.4 kg (3.09 lb)

TIS 500

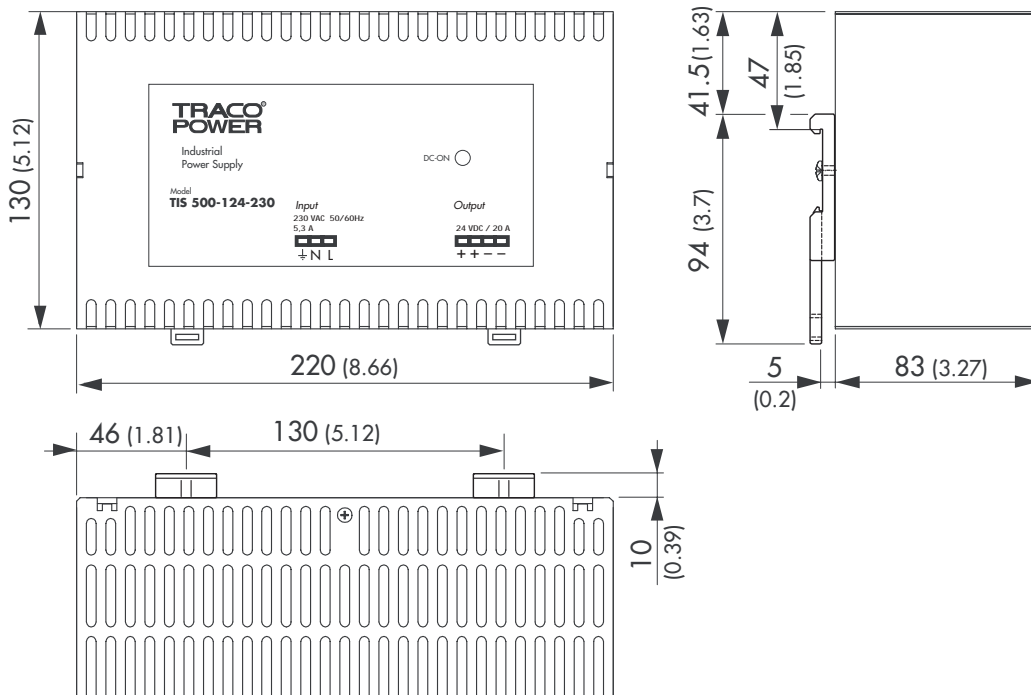

Weight:
TIS 500 1.9 kg (4.19 lb)

Outline Dimensions mm (inches)

TIS 600

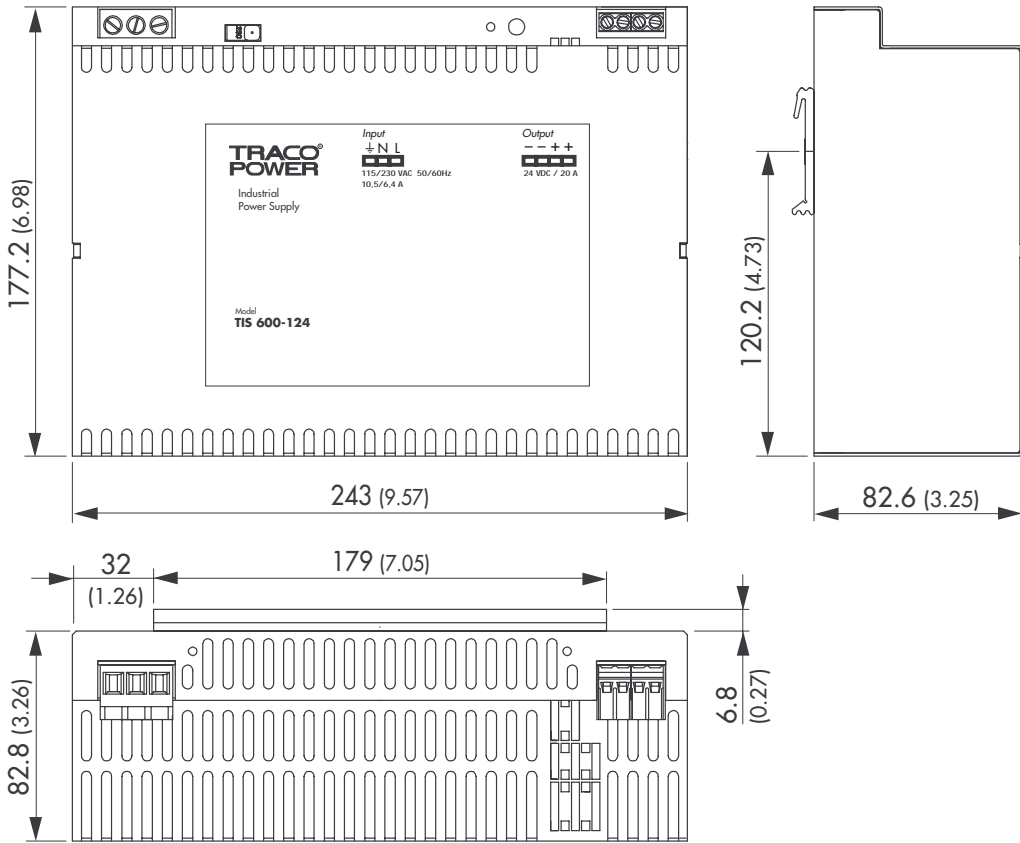

Weight:
TIS 600 2.0 kg (4.41 lb)

Optional Mounting Systems Dimensions mm (inches)

Wall mounting

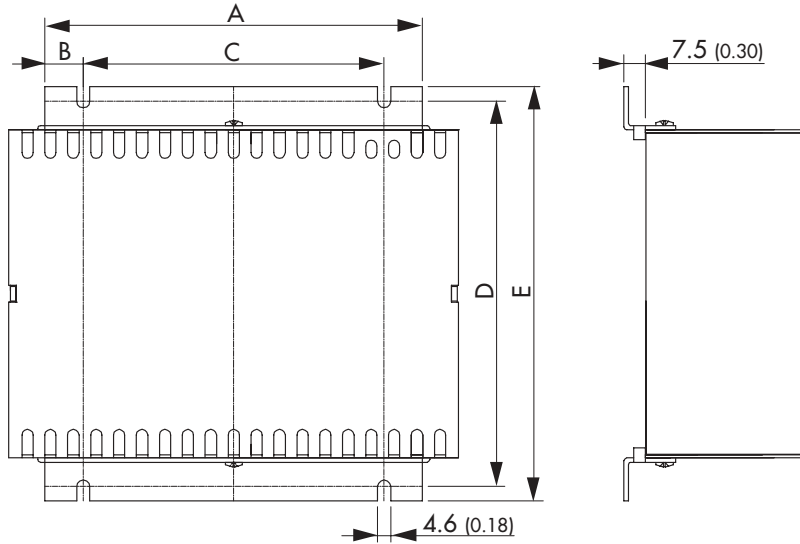

Models	Order code	A	B	C	D	E
TIS 75W	MK-75	37 (1.46)	14.5 (0.57)	-	134.5 (5.30)	150.5 (5.93)
TIS 150W	MK-150	132 (5.20)	13.5 (0.53)	105 (4.13)	134.5 (5.30)	150.5 (5.93)
TIS 300W	MK-300	132 (5.20)	13.5 (0.53)	105 (4.13)	134.5 (5.30)	150.5 (5.93)
TIS 500W	MK-500	132 (5.20)	13.5 (0.53)	105 (4.13)	134.5 (5.30)	150.5 (5.93)
TIS 600W	MK-600	190 (7.48)	37.5 (1.48)	115 (4.53)	197.0 (7.76)	207.0 (8.15)

Rugged DIN-Rail mounting

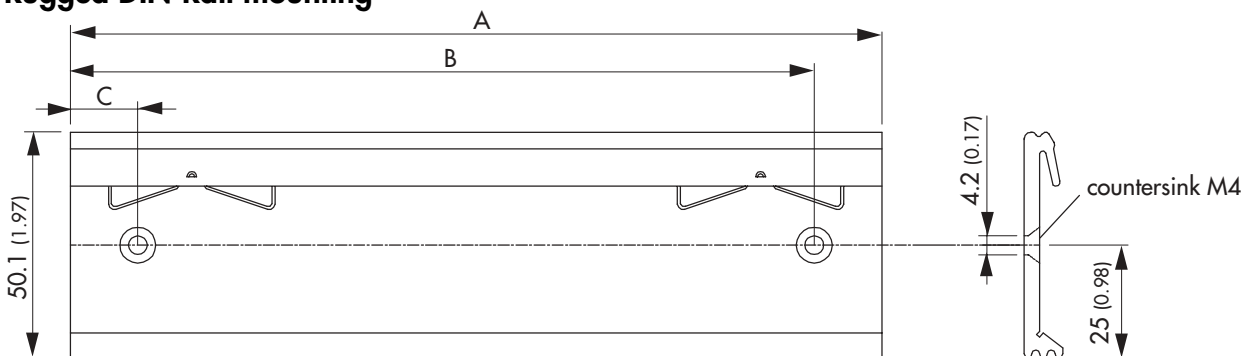

Models	Order code	A	B	C
TIS 150W	RMK-150	150 (5.91)	115 (4.53)	35 (1.38)
TIS 300W	RMK-300	200 (7.87)	165 (6.50)	35 (1.38)
TIS 500W	RMK-300	200 (7.87)	165 (6.50)	35 (1.38)
TIS 600W	standard	180 (7.09)	165 (6.50)	15.0 (0.59)

Specifications can be changed without notice

Tolerances: ± 0.5 mm (± 0.02)

Outline Dimensions mm (inches)

TIS-24-32 AP

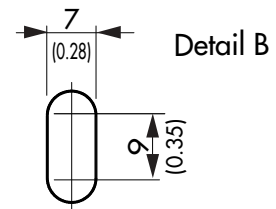
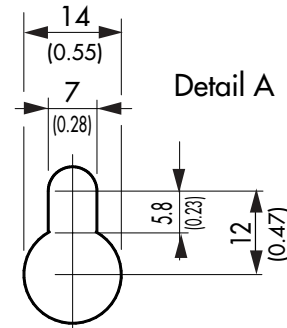
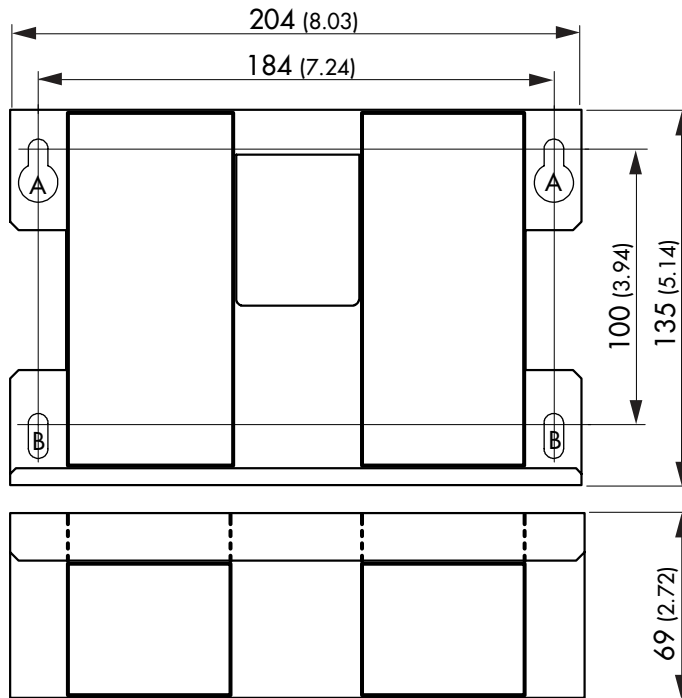

Weight (incl. batteries):

TIS-24-32 AP 4.6 kg (10.1 lb)

TIS-24-70 AP 5.9 kg (13.0 lb)

TIS-24-70 AP

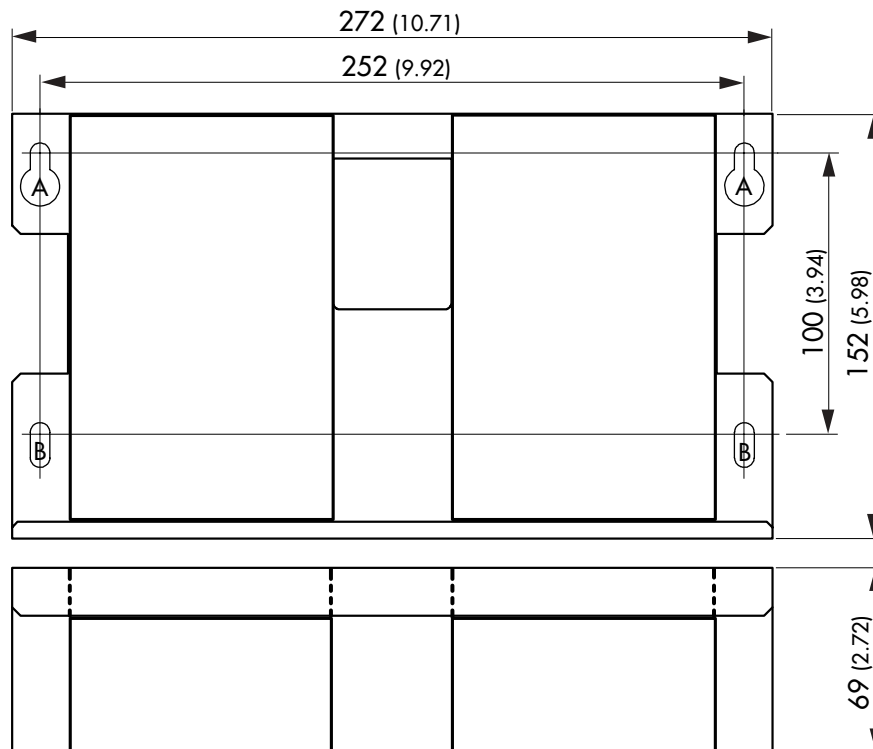

Specifications can be changed without notice

Tolerances: ± 0.5 mm (± 0.02)