

## DUAL PROCESSOR SUPERVISORY CIRCUITS WITH POWER-FAIL

### FEATURES

- Dual Supervisory Circuits With Power-Fail for DSP and Processor-Based Systems
- Voltage Monitor for Power-Fail or Low-Battery Warning
- Watchdog Timer With 0.8 Second Time-Out
- Power-On Reset Generator With Integrated 100 ms Delay Time
- Open-Drain Reset and Power-Fail Output
- Supply Current of 15  $\mu$ A (Typ.)
- Supply Voltage Range . . . 2.7 V to 6 V
- Defined  $\overline{\text{RESET}}$  Output From  $V_{\text{DD}} \geq 1.1$  V
- MSOP-8 and SO-8 Packages
- Temperature Range . . . -40°C to 85°C

### APPLICATIONS

- Multivoltage DSPs and Processors
- Portable Battery-Powered Equipment
- Embedded Control Systems
- Intelligent Instruments
- Automotive Systems

D OR DGK PACKAGE  
(TOP VIEW)

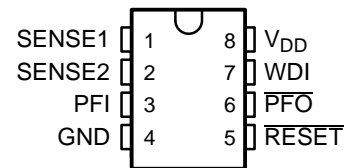

### DESCRIPTION

The TPS3306 family is a series of supervisory circuits designed for circuit initialization which require two supply voltages, primarily in DSP and processor-based systems.

The product spectrum of the TPS3306-xx is designed for monitoring two independent supply voltages of 3.3 V/1.5 V, 3.3 V/1.8 V, 3.3 V/2 V, 3.3 V/2.5 V, or 3.3 V/5 V.

TYPICAL OPERATING CIRCUIT

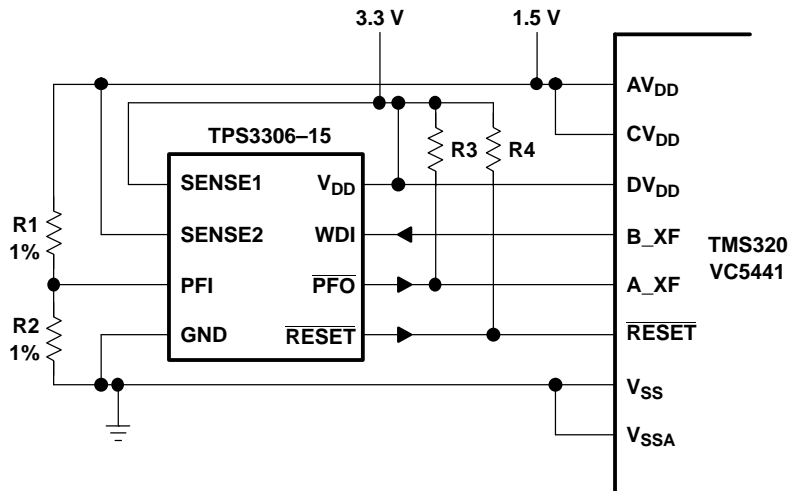

Please be aware that an important notice concerning availability, standard warranty, and use in critical applications of Texas Instruments semiconductor products and disclaimers thereto appears at the end of this data sheet.

The various supervisory circuits are designed to monitor the nominal supply voltage, as shown in the following supply voltage monitoring table.

### SUPPLY VOLTAGE MONITORING

DEVICE	NOMINAL SUPERVISED VOLTAGE		THRESHOLD VOLTAGE (typ)	
	SENSE1	SENSE2	SENSE1	SENSE2
TPS3306-15	3.3 V	1.5 V	2.93 V	1.4 V
TPS3306-18	3.3 V	1.8 V	2.93 V	1.68 V
TPS3306-20	3.3 V	2 V	2.93 V	1.85 V
TPS3306-25	3.3 V	2.5 V	2.93 V	2.25 V
TPS3306-33	5 V	3.3 V	4.55 V	2.93 V

During power-on,  $\overline{\text{RESET}}$  is asserted when the supply voltage  $V_{DD}$  becomes higher than 1.1 V. Thereafter, the supervisory circuits monitor the SENSEn inputs and keep  $\overline{\text{RESET}}$  active as long as SENSEn remains below the threshold voltage  $V_{IT}$ .

An internal timer delays the return of the  $\overline{\text{RESET}}$  output to the inactive state (high) to ensure proper system reset. The delay time,  $t_{d(\text{typ})} = 100 \text{ ms}$ , starts after SENSE1 and SENSE2 inputs have risen above the threshold voltage  $V_{IT}$ . When the voltage at SENSE1 or SENSE2 input drops below the threshold voltage  $V_{IT}$ , the output becomes active (low) again.

The integrated power-fail (PFI) comparator with separate open-drain ( $\overline{\text{PFO}}$ ) output can be used for low-battery detection, power-fail warning, or for monitoring a power supply other than the main supply.

The TPS3306-xx devices integrate a watchdog timer that is periodically triggered by a positive or negative transition of WDI. When the supervising system fails to retrigger the watchdog circuit within the time-out interval,  $t_{t(\text{out})} = 0.50 \text{ s}$ ,  $\overline{\text{RESET}}$  becomes active for the time period  $t_d$ . This event also reinitializes the watchdog timer. Leaving WDI unconnected disables the watchdog.

The TPS3306-xx devices are available in either 8-pin MSOP or standard 8-pin SO packages, and are characterized for operation over a temperature range of  $-40^\circ\text{C}$  to  $85^\circ\text{C}$ .

### AVAILABLE OPTIONS

$T_A$	PACKAGED DEVICES		MARKING DGK PACKAGE
	SMALL OUTLINE (D)	$\mu$ -SMALL OUTLINE (DGK)	
$-40^\circ\text{C}$ to $85^\circ\text{C}$	TPS3306-15D	TPS3306-15DGK	TIAIC
	TPS3306-18D	TPS3306-18DGK	TIAID
	TPS3306-20D	TPS3306-20DGK	TIAIE
	TPS3306-25D	TPS3306-25DGK	TIAIF
	TPS3306-33D	TPS3306-33DGK	TIAIG

### FUNCTION/TRUTH TABLES

SENSE1 > $V_{IT1}$	SENSE2 > $V_{IT2}$	RESET
0	0	L
0	1	L
1	0	L
1	1	H

### FUNCTION/TRUTH TABLES

PFI > $V_{IT}$	$\overline{\text{PFO}}$	TYPICAL DELAY
0"1	L"H	0.5 $\mu\text{s}$
1"0	H"L	0.5 $\mu\text{s}$

### FUNCTIONAL BLOCK DIAGRAM

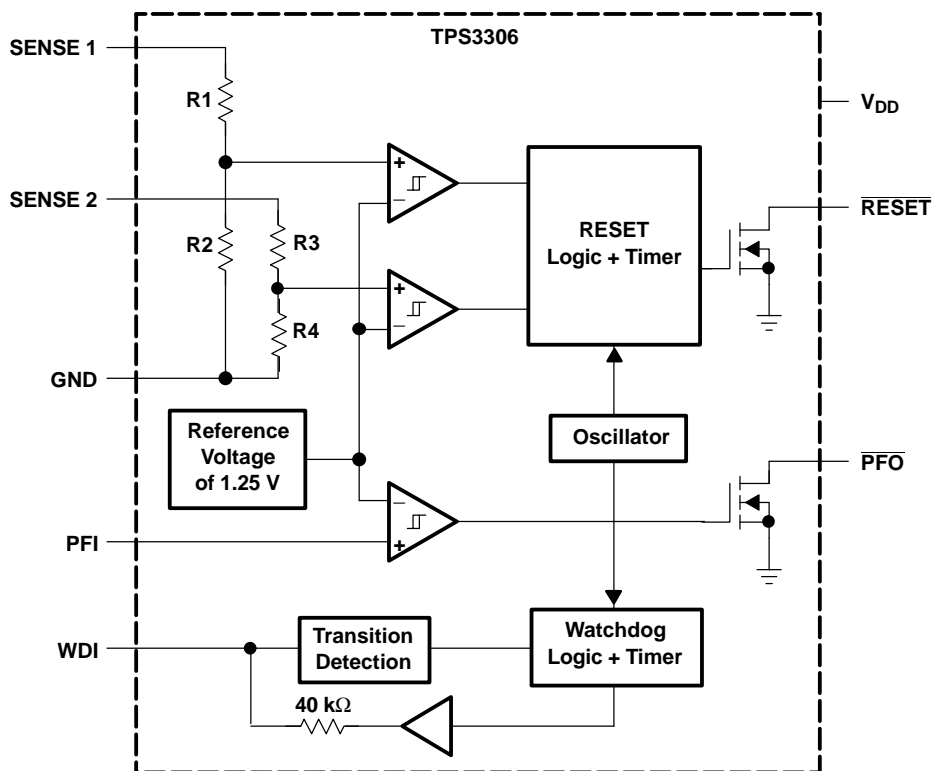

### TIMING DIAGRAM

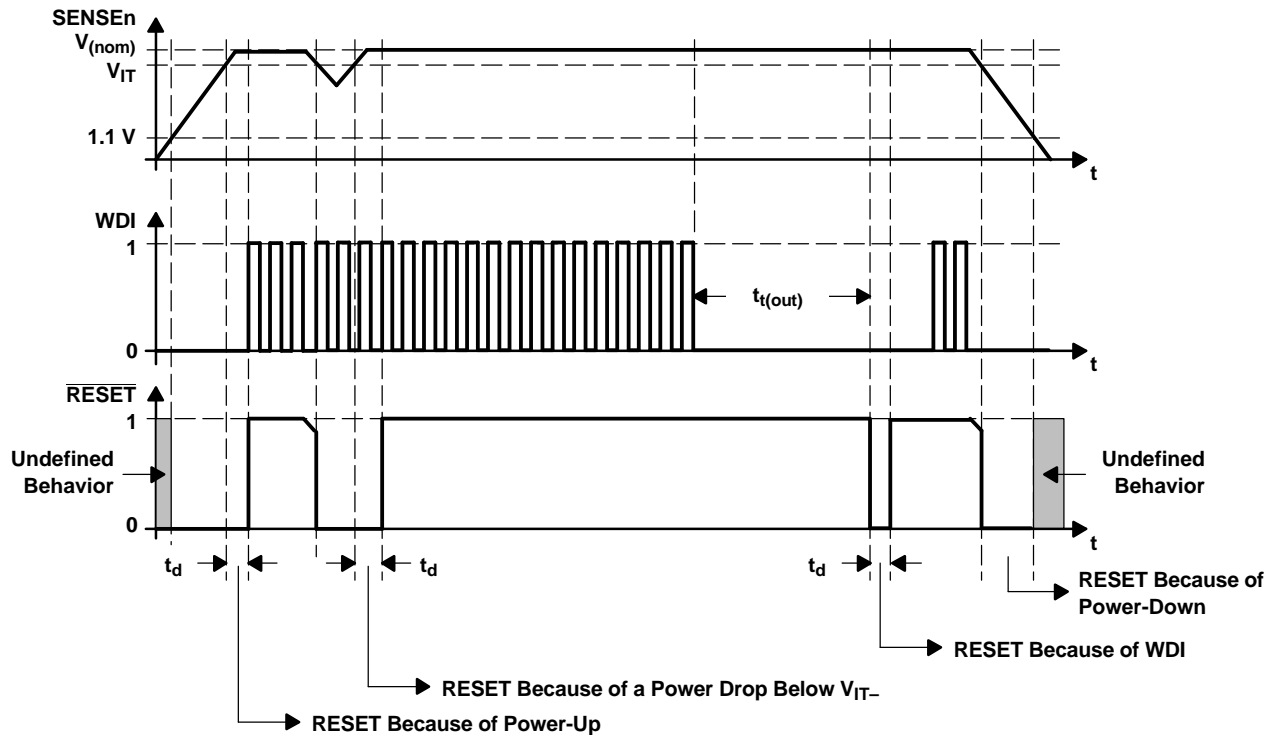

### Terminal Functions

TERMINAL NAME	NO.	I/O	DESCRIPTION
GND	4	I	Ground
PFI	3	I	Power-fail comparator input
$\overline{PFO}$	6	O	Power-fail comparator output, open-drain
$\overline{RESET}$	5	O	Active-low reset output, open-drain
SENSE1	1	I	Sense voltage input 1
SENSE2	2	I	Sense voltage input 2
WDI	7	I	Watchdog timer input
$V_{DD}$	8	I	Supply voltage

### DETAILED DESCRIPTION

#### Watchdog

In a microprocessor- or DSP-based system, it is not only important to supervise the supply voltage, it is also important to ensure correct program execution. The task of a watchdog is to ensure that the program is not stalled in an indefinite loop. The microprocessor, microcontroller, or DSP has to typically toggle the watchdog input within 0.8 s to avoid a time out occurring. Either a low-to-high or a high-to-low transition resets the internal watchdog timer. If the input is unconnected or tied with a high impedance driver, the watchdog is disabled and will be retriggered internally.

**DETAILED DESCRIPTION (continued)**

**Saving Current While Using the Watchdog**

The watchdog input is internally driven low during the first 7/8 of the watchdog time-out period, then momentarily pulses high, resetting the watchdog counter. For minimum watchdog input current (minimum overall power consumption), leave WDI low for the majority of the watchdog time-out period, pulsing it low-high-low once within 7/8 of the watchdog time-out period to reset the watchdog timer. If instead WDI is externally driven high for the majority of the time-out period, a current of  $5 \text{ V}/40 \text{ k}\Omega \approx 125 \mu\text{A}$  can flow into WDI.

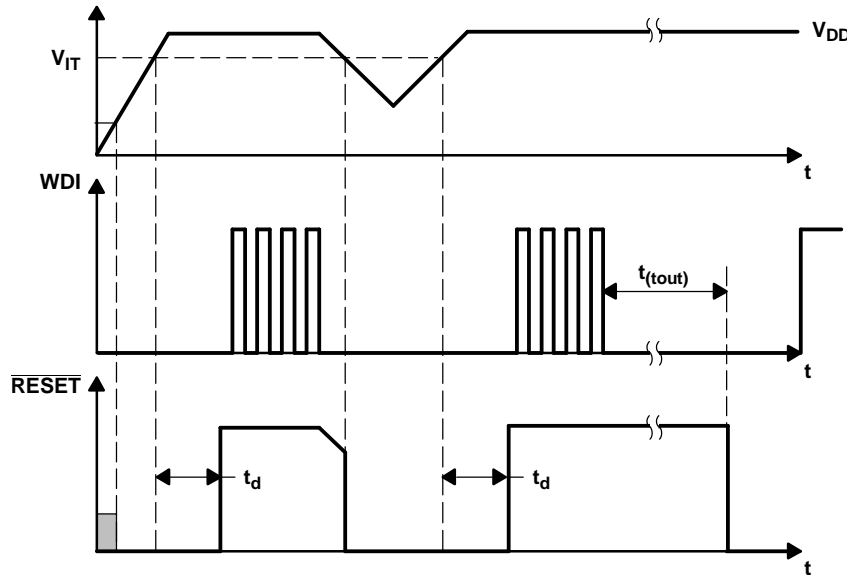

**Figure 1. Watchdog Timing**

**Power-Fail Comparator (PFI and  $\overline{\text{PFO}}$ )**

An additional comparator is provided to monitor voltages other than the nominal supply voltage. The power-fail-input (PFI) will be compared with an internal voltage reference of 1.25 V. If the input voltage falls below the power-fail threshold ( $V_{\text{PFI}}$ ) of typ. 1.25 V, the power-fail output ( $\overline{\text{PFO}}$ ) goes low. If it goes above 1.25 V plus about 10 mV hysteresis, the output returns to high. By connecting two external resistors, it is possible to supervise any voltages above 1.25 V. The sum of both resistors should be about 1 M $\Omega$ , to minimize power consumption and also to assure that the current in the PFI pin can be neglected compared with the current through the resistor network. The tolerance of the external resistors should be not more than 1% to ensure minimal variation of sensed voltage. If the power-fail comparator is unused, connect PFI to ground and leave  $\overline{\text{PFO}}$  unconnected.

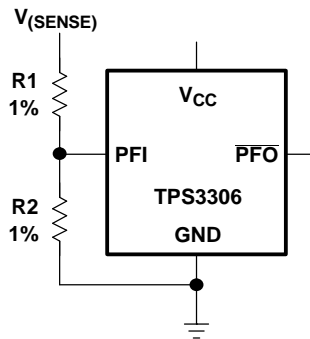

$$V_{\text{PFI,trip}} = 1.25 \text{ V} \times \frac{R_1 + R_2}{R_2}$$

## ABSOLUTE MAXIMUM RATINGS

over operating free-air temperature range (unless otherwise noted)<sup>(1)</sup>

	UNIT
Supply voltage, $V_{DD}$ (see <sup>(2)</sup> )	7 V
All other pins (see <sup>(2)</sup> )	-0.3 V to 7 V
Maximum low output current, $I_{OL}$	5 mA
Maximum high output current, $I_{OH}$	- 5 mA
Input clamp current, $I_{IK}$ ( $V_I < 0$ or $V_I > V_{DD}$ )	$\pm 20$ mA
Output clamp current, $I_{OK}$ ( $V_O < 0$ or $V_O > V_{DD}$ )	$\pm 20$ mA
Continuous total power dissipation	See Dissipation Rating Table
Operating free-air temperature range, $T_A$	-40°C to 85°C
Storage temperature range, $T_{stg}$	-65°C to 150°C
Soldering temperature	260°C

- (1) Stresses beyond those listed under *absolute maximum ratings* may cause permanent damage to the device. These are stress ratings only, and functional operation of the device at these or any other conditions beyond those indicated under *recommended operating conditions* is not implied. Exposure to absolute-maximum-rated conditions for extended periods may affect device reliability.
- (2) All voltage values are with respect to GND. For reliable operation, the device must not be operated at 7 V for more than  $t = 1000$  h continuously.

## DISSIPATION RATING TABLE

PACKAGE	$T_A \leq 25^\circ\text{C}$ POWER RATING	DERATING FACTOR ABOVE $T_A = 25^\circ\text{C}$	$T_A = 70^\circ\text{C}$ POWER RATING	$T_A = 85^\circ\text{C}$ POWER RATING
DGK	424 mW	3.4 mW/°C	271 mW	220 mW
D	725 mW	5.8 mW/°C	464 mW	377 mW

## RECOMMENDED OPERATING CONDITIONS

at specified temperature range

	MIN	MAX	UNIT
Supply voltage, $V_{DD}$	2.7	6	V
Input voltage at WDI and PFI, $V_I$	0	$V_{DD} + 0.3$	V
Input voltage at SENSE1 and SENSE2, $V_I$	0	$(V_{DD} + 0.3)V_{IT}/1.25$ V	V
High-level input voltage at WDI, $V_{IH}$	$0.7 \times V_{DD}$		V
Low-level input voltage at WDI, $V_{IL}$		$0.3 \times V_{DD}$	V
Operating free-air temperature range, $T_A$	-40	85	°C

## ELECTRICAL CHARACTERISTICS

over recommended operating free-air temperature range (unless otherwise noted)

PARAMETER		TEST CONDITIONS	MIN	TYP	MAX	UNIT		
V <sub>OL</sub>	Low-level output voltage	$\overline{\text{RESET}}$ , PFO $V_{DD} = 2.7 \text{ V to } 6 \text{ V}$ , $I_{OL} = 20 \mu\text{A}$ $V_{DD} = 3.3 \text{ V}$ , $I_{OL} = 2 \text{ mA}$ $V_{DD} = 6 \text{ V}$ , $I_{OL} = 3 \text{ mA}$			0.2	V		
					0.4			
					0.4			
Power-up reset voltage (see <sup>(1)</sup> )		$V_{DD} \geq 1.1 \text{ V}$ , $I_{OL} = 20 \mu\text{A}$			0.4	V		
V <sub>IT</sub>	Negative-going input threshold voltage (see <sup>(2)</sup> )	$V_{DD} = 2.7 \text{ V to } 6 \text{ V}$ $T_A = 0^\circ\text{C to } 85^\circ\text{C}$		1.37	1.40	1.43	V	
				1.64	1.68	1.72		
				1.81	1.85	1.89		
				2.20	2.25	2.30		
				2.86	2.93	3		
		PFI	$V_{DD} = 2.7 \text{ V to } 6 \text{ V}$ $T_A = -40^\circ\text{C to } 85^\circ\text{C}$		1.22	1.25	1.28	V
					1.37	1.40	1.44	
					1.64	1.68	1.73	
					1.81	1.85	1.90	
					2.20	2.25	2.32	
V <sub>hys</sub>	Hysteresis	PFI	V <sub>IT</sub> = 1.25 V			10	mV	
				V <sub>SENSEn</sub>	V <sub>IT</sub> = 1.40 V			15
					V <sub>IT</sub> = 1.68 V			15
					V <sub>IT</sub> = 1.86 V			20
					V <sub>IT</sub> = 2.25 V			20
					V <sub>IT</sub> = 2.93 V			30
V <sub>IT</sub> = 4.55 V		40						
I <sub>H(AV)</sub>	Average high-level input current	WDI	WDI = V <sub>DD</sub> = 6 V, Time average (dc = 88%)		100	150	μA	
I <sub>L(AV)</sub>	Average low-level input current			WDI = 0 V, V <sub>DD</sub> = 6 V, Time average (dc = 12%)		-15		-20
I <sub>H</sub>	High-level input current	WDI	WDI = V <sub>DD</sub> = 6 V		120	170	μA	
		SENSE1	V <sub>SENSE1</sub> = V <sub>DD</sub> = 6 V		5	8		
		SENSE2	V <sub>SENSE2</sub> = V <sub>DD</sub> = 6 V		6	9		
I <sub>L</sub>	Low-level input current	WDI	WDI = 0 V, V <sub>DD</sub> = 6 V		-120	-170	μA	
I <sub>I</sub>	Input current	PFI	V <sub>DD</sub> = 6 V, 0 V ≤ V <sub>I</sub> ≤ V <sub>DD</sub>		-25	25	nA	
I <sub>DD</sub>	Supply current				15	40	μA	
C <sub>i</sub>	Input capacitance		V <sub>I</sub> = 0 V to V <sub>DD</sub>		10		pF	

(1) The lowest supply voltage at which  $\overline{\text{RESET}}$  becomes active.  $t_r$ ,  $V_{DD} \geq 15 \mu\text{s/V}$ .

(2) To ensure best stability of the threshold voltage, a bypass capacitor (ceramic 0.1 μF) should be placed close to the supply terminals.

## TIMING REQUIREMENTS

at  $V_{DD} = 2.7\text{ V to }6\text{ V}$ ,  $R_L = 1\text{ M}\Omega$ ,  $C_L = 50\text{ pF}$ ,  $T_A = 25^\circ\text{C}$

PARAMETER		TEST CONDITIONS	MIN	TYP	MAX	UNIT
$t_w$	Pulse width					
	SENSEn	$V_{SENSEnL} = V_{IT} - 0.2\text{ V}$ , $V_{SENSEnH} = V_{IT} + 0.2\text{ V}$	6			$\mu\text{s}$
	WDI	$V_{IH} = 0.7 \times V_{DD}$ , $V_{IL} = 0.3 \times V_{DD}$	100			ns

## SWITCHING CHARACTERISTICS

at  $V_{DD} = 2.7\text{ V to }6\text{ V}$ ,  $R_L = 1\text{ M}\Omega$ ,  $C_L = 50\text{ pF}$ ,  $T_A = 25^\circ\text{C}$

PARAMETER		TEST CONDITIONS	MIN	TYP	MAX	UNIT
$t_{t(out)}$	Watchdog time out	$V_{I(SENSEn)} \geq V_{IT} + 0.2\text{ V}$ , See timing diagram	0.5	0.8	1.2	s
$t_d$	Delay time	$V_{I(SENSEn)} \geq V_{IT} + 0.2\text{ V}$ , See timing diagram	70	100	140	ms
$t_{PHL}$	Propagation (delay) time, high-to-low level output	SENSEn to $\overline{\text{RESET}}$		1	5	$\mu\text{s}$
$t_{PHL}$	Propagation (delay) time, high-to-low level output	PFI to $\overline{\text{PFO}}$		0.5	1	$\mu\text{s}$
$t_{PLH}$	Propagation (delay) time, low-to-high level output					



TYPICAL CHARACTERISTICS

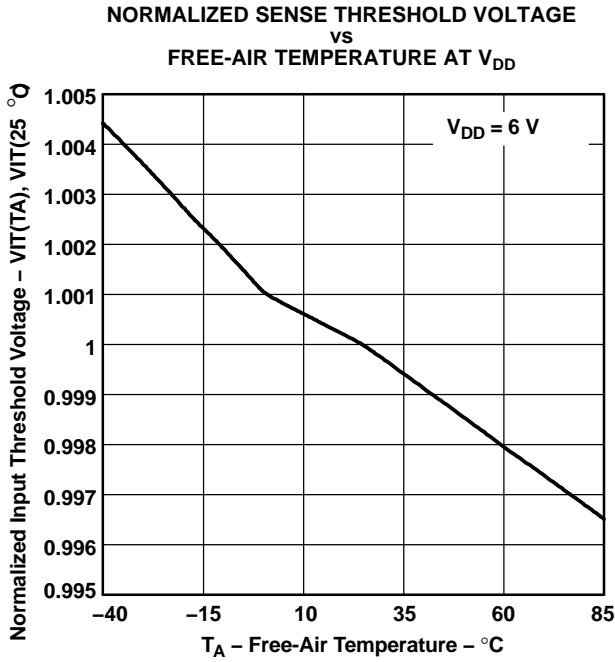

Figure 2.

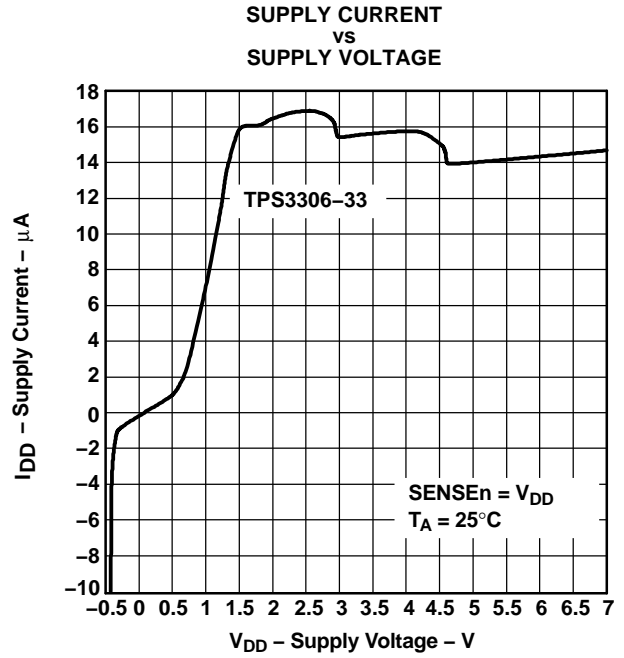

Figure 3.

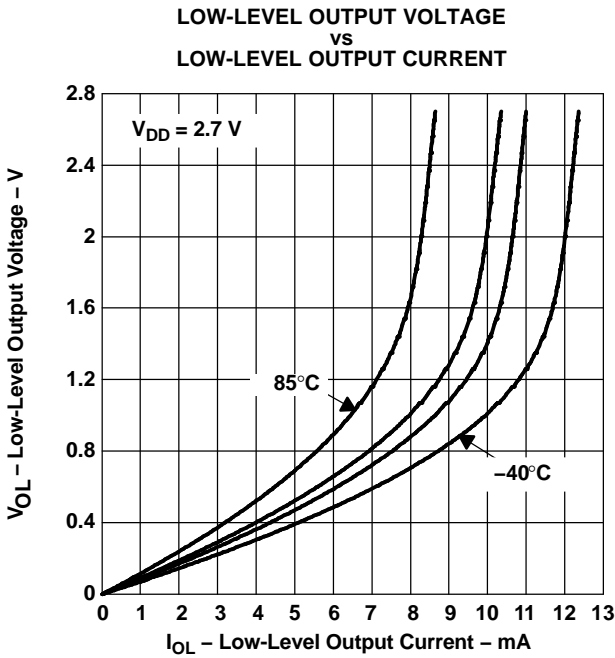

Figure 4.

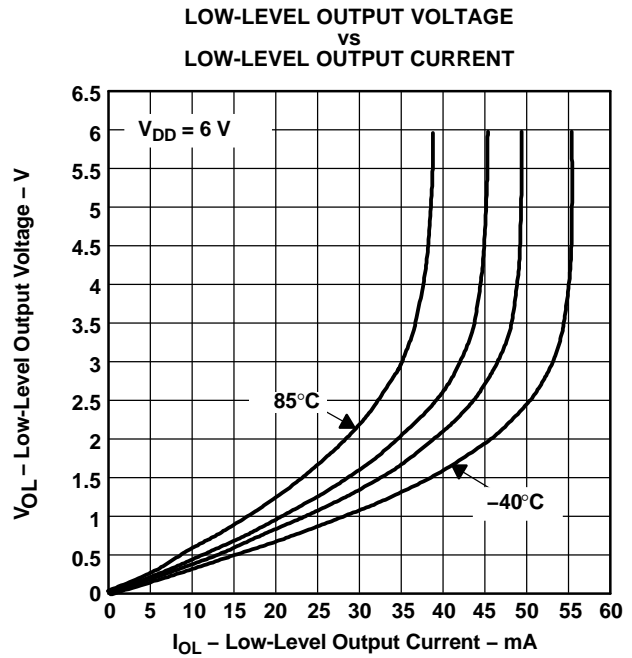

Figure 5.

TYPICAL CHARACTERISTICS (continued)

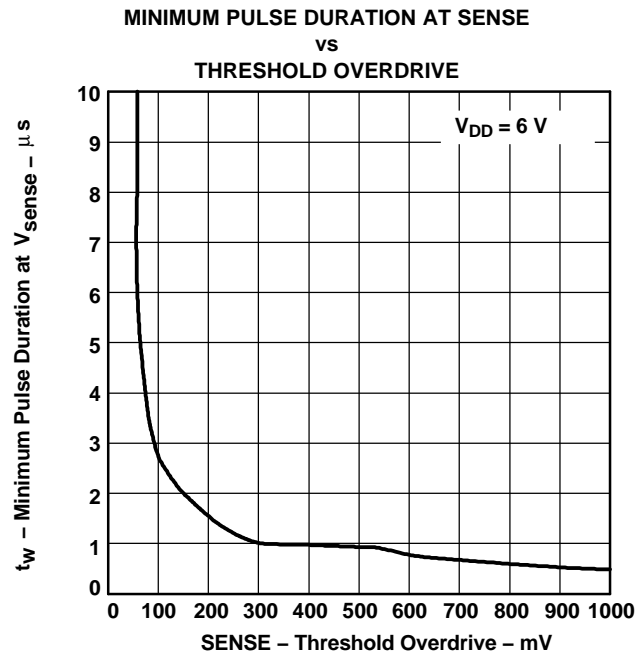
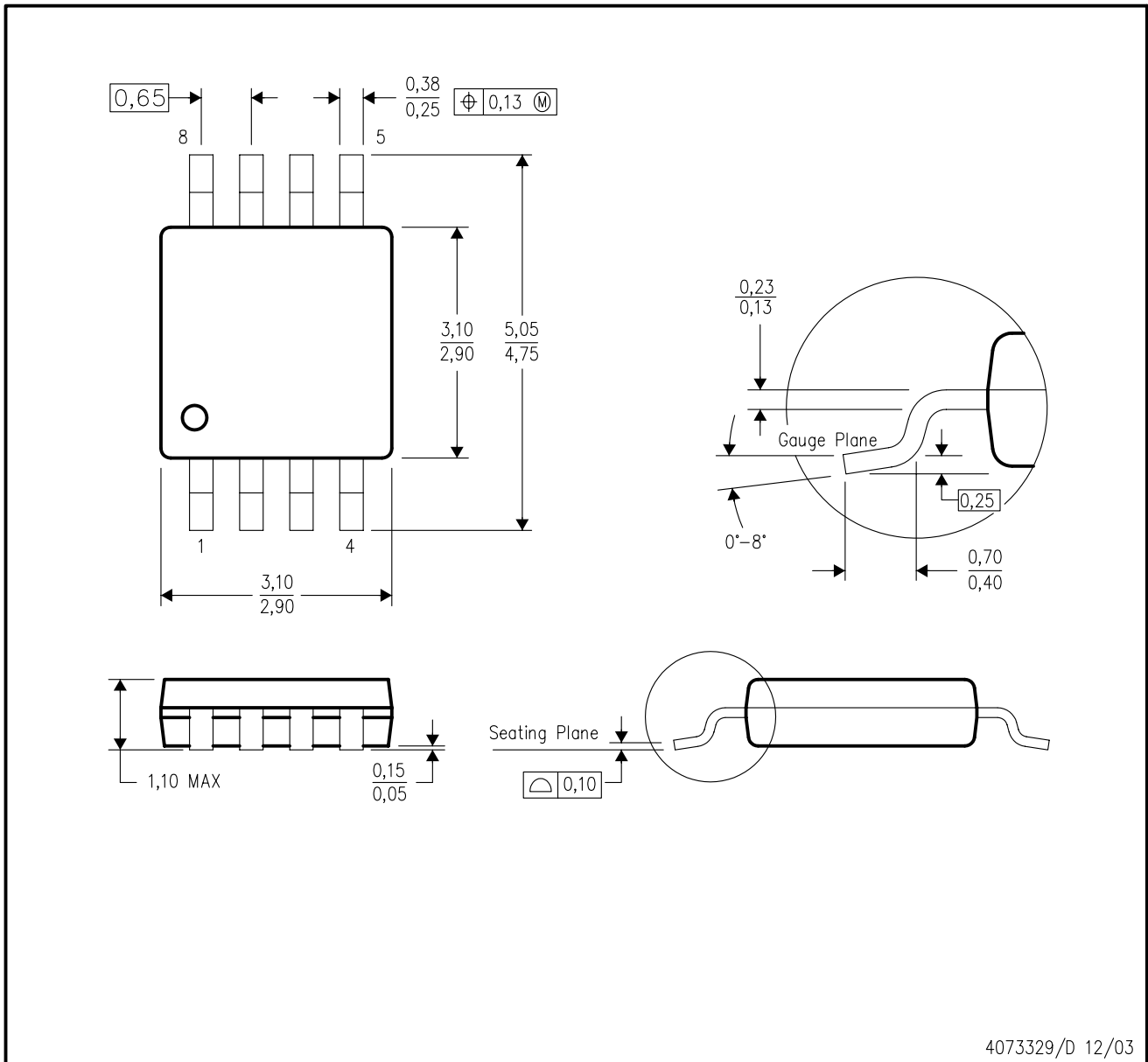

Figure 6.

DGK (S-PDSO-G8)

PLASTIC SMALL-OUTLINE PACKAGE



- NOTES:
- A. All linear dimensions are in millimeters.
  - B. This drawing is subject to change without notice.
  - C. Body dimensions do not include mold flash or protrusion.
  - D. Falls within JEDEC MO-187 variation AA.

D (R-PDSO-G\*\*)

PLASTIC SMALL-OUTLINE PACKAGE

8 PINS SHOWN

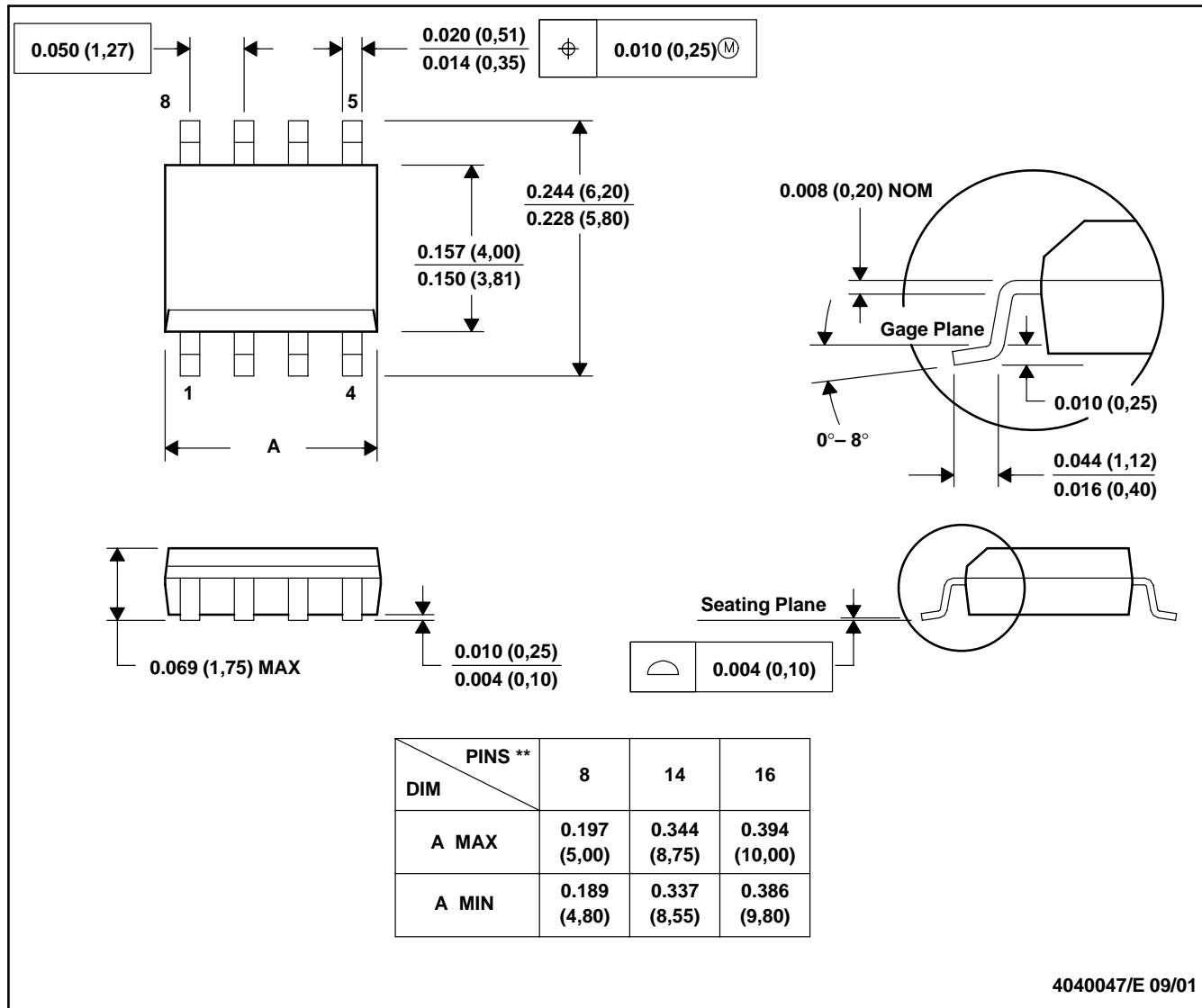

- NOTES: A. All linear dimensions are in inches (millimeters).  
 B. This drawing is subject to change without notice.  
 C. Body dimensions do not include mold flash or protrusion, not to exceed 0.006 (0,15).  
 D. Falls within JEDEC MS-012

## IMPORTANT NOTICE

Texas Instruments Incorporated and its subsidiaries (TI) reserve the right to make corrections, modifications, enhancements, improvements, and other changes to its products and services at any time and to discontinue any product or service without notice. Customers should obtain the latest relevant information before placing orders and should verify that such information is current and complete. All products are sold subject to TI's terms and conditions of sale supplied at the time of order acknowledgment.

TI warrants performance of its hardware products to the specifications applicable at the time of sale in accordance with TI's standard warranty. Testing and other quality control techniques are used to the extent TI deems necessary to support this warranty. Except where mandated by government requirements, testing of all parameters of each product is not necessarily performed.

TI assumes no liability for applications assistance or customer product design. Customers are responsible for their products and applications using TI components. To minimize the risks associated with customer products and applications, customers should provide adequate design and operating safeguards.

TI does not warrant or represent that any license, either express or implied, is granted under any TI patent right, copyright, mask work right, or other TI intellectual property right relating to any combination, machine, or process in which TI products or services are used. Information published by TI regarding third-party products or services does not constitute a license from TI to use such products or services or a warranty or endorsement thereof. Use of such information may require a license from a third party under the patents or other intellectual property of the third party, or a license from TI under the patents or other intellectual property of TI.

Reproduction of information in TI data books or data sheets is permissible only if reproduction is without alteration and is accompanied by all associated warranties, conditions, limitations, and notices. Reproduction of this information with alteration is an unfair and deceptive business practice. TI is not responsible or liable for such altered documentation.

Resale of TI products or services with statements different from or beyond the parameters stated by TI for that product or service voids all express and any implied warranties for the associated TI product or service and is an unfair and deceptive business practice. TI is not responsible or liable for any such statements.

Following are URLs where you can obtain information on other Texas Instruments products and application solutions:

<b>Products</b>		<b>Applications</b>	
Amplifiers	<a href="http://amplifier.ti.com">amplifier.ti.com</a>	Audio	<a href="http://www.ti.com/audio">www.ti.com/audio</a>
Data Converters	<a href="http://dataconverter.ti.com">dataconverter.ti.com</a>	Automotive	<a href="http://www.ti.com/automotive">www.ti.com/automotive</a>
DSP	<a href="http://dsp.ti.com">dsp.ti.com</a>	Broadband	<a href="http://www.ti.com/broadband">www.ti.com/broadband</a>
Interface	<a href="http://interface.ti.com">interface.ti.com</a>	Digital Control	<a href="http://www.ti.com/digitalcontrol">www.ti.com/digitalcontrol</a>
Logic	<a href="http://logic.ti.com">logic.ti.com</a>	Military	<a href="http://www.ti.com/military">www.ti.com/military</a>
Power Mgmt	<a href="http://power.ti.com">power.ti.com</a>	Optical Networking	<a href="http://www.ti.com/opticalnetwork">www.ti.com/opticalnetwork</a>
Microcontrollers	<a href="http://microcontroller.ti.com">microcontroller.ti.com</a>	Security	<a href="http://www.ti.com/security">www.ti.com/security</a>
		Telephony	<a href="http://www.ti.com/telephony">www.ti.com/telephony</a>
		Video & Imaging	<a href="http://www.ti.com/video">www.ti.com/video</a>
		Wireless	<a href="http://www.ti.com/wireless">www.ti.com/wireless</a>

Mailing Address: Texas Instruments  
Post Office Box 655303 Dallas, Texas 75265

Copyright © 2004, Texas Instruments Incorporated