

## Processor Supervisory Circuits with Window-Watchdog

### FEATURES

- **Window-Watchdog With Programmable Delay and Window Ratio**
- **6-Pin SOT-23 Package**
- **Supply Current of 9  $\mu\text{A}$  (Typ)**
- **Power On Reset Generator With a Fixed Delay Time of 25 ms**
- **Precision Supply Voltage Monitor 2.5 V, 3 V, 3.3 V, 5 V**
- **Open-Drain Reset Output**
- **Temperature Range  $-40^{\circ}\text{C}$  to  $+85^{\circ}\text{C}$**

### APPLICATIONS

- **Applications Using DSPs, Microcontrollers, or Microprocessors**
- **Safety Critical Systems**
- **Automotive Systems**
- **Heating Systems**

### DESCRIPTION

The TPS3813 family of supervisory circuits provide circuit initialization and timing supervision, primarily for DSPs and processor-based systems.

During power on,  $\overline{\text{RESET}}$  is asserted when supply voltage ( $V_{\text{DD}}$ ) becomes higher than 1.1 V. Thereafter, the supervisory circuit monitors  $V_{\text{DD}}$  and keeps  $\overline{\text{RESET}}$  active as long as  $V_{\text{DD}}$  remains below the threshold voltage ( $V_{\text{IT}}$ ). An internal timer delays the return of the output to the inactive state (high) to ensure proper system reset. The delay time,  $t_d = 25$  ms typical, starts after  $V_{\text{DD}}$  has risen above the threshold voltage ( $V_{\text{IT}}$ ). When the supply voltage drops below the threshold voltage ( $V_{\text{IT}}$ ), the output becomes active (low) again. No external components are required. All the devices of this family have a fixed-sense threshold voltage ( $V_{\text{IT}}$ ) set by an internal voltage divider.

For safety critical applications the TPS3813 family incorporates a so-called window-watchdog with programmable delay and window ratio. The upper limit of the watchdog time-out can be set by either connecting WDT to GND,  $V_{\text{DD}}$ , or using an external capacitor. The lower limit and thus the window ratio is set by connecting WDR to GND or  $V_{\text{DD}}$ . The supervised processor now needs to trigger the TPS3813 within this window not to assert a  $\overline{\text{RESET}}$ .

The product spectrum is designed for supply voltages of 2.5 V, 3 V, 3.3 V, and 5 V. The circuits are available in a 6-pin SOT-23 package.

The TPS3813 devices are characterized for operation over a temperature range of  $-40^{\circ}\text{C}$  to  $85^{\circ}\text{C}$ .

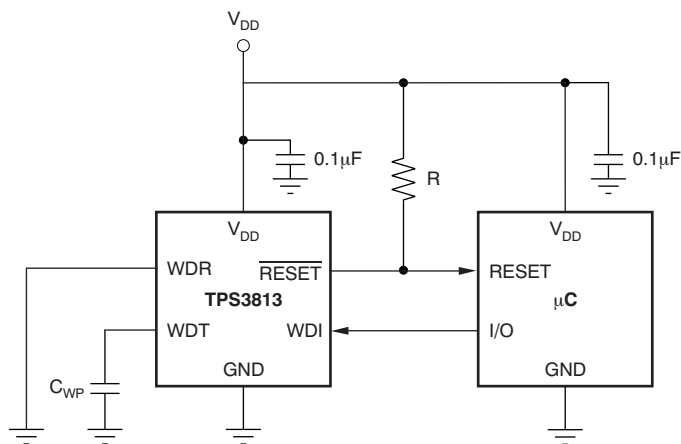

Typical Operating Circuit

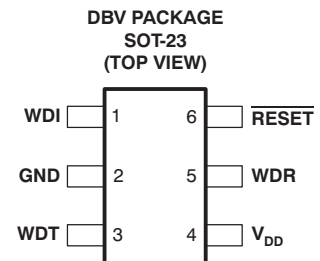

Please be aware that an important notice concerning availability, standard warranty, and use in critical applications of Texas Instruments semiconductor products and disclaimers thereto appears at the end of this data sheet.

All trademarks are the property of their respective owners.



This integrated circuit can be damaged by ESD. Texas Instruments recommends that all integrated circuits be handled with appropriate precautions. Failure to observe proper handling and installation procedures can cause damage.

ESD damage can range from subtle performance degradation to complete device failure. Precision integrated circuits may be more susceptible to damage because very small parametric changes could cause the device not to meet its published specifications.

## PACKAGE AND ORDERING INFORMATION

### PACKAGE INFORMATION<sup>(1)</sup>

T <sub>A</sub>	DEVICE NAME	THRESHOLD VOLTAGE	MARKING
–40°C to +85°C	TPS3813J25DBV	2.25 V	PCDI
	TPS3813L30DBV	2.64 V	PEZI
	TPS3813K33DBV	2.93 V	PFAI
	TPS3813I50DBV	4.55 V	PFBI

- (1) For the most current package and ordering information see the Package Option Addendum at the end of this document, or see the TI web site at [www.ti.com](http://www.ti.com).

### ORDERING INFORMATION

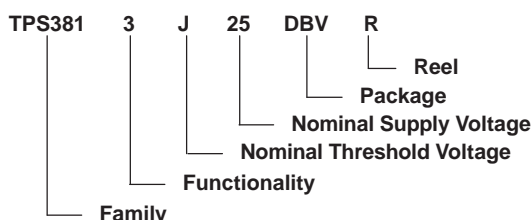

## ABSOLUTE MAXIMUM RATINGS

Over operating free-air temperature range (unless otherwise noted).<sup>(1)</sup>

		UNIT
V <sub>DD</sub>	Supply voltage <sup>(2)</sup>	7 V
	RESET	–0.3 V to V <sub>DD</sub> + 0.3 V
	All other pins <sup>(2)</sup>	–0.3 V to 7 V
I <sub>OL</sub>	Maximum low output current	5 mA
I <sub>OH</sub>	Maximum high output current	–5 mA
I <sub>IK</sub>	Input clamp current (V <sub>I</sub> < 0 or V <sub>I</sub> > V <sub>DD</sub> )	±20 mA
I <sub>OK</sub>	Output clamp current (V <sub>O</sub> < 0 or V <sub>O</sub> > V <sub>DD</sub> )	±20 mA
Continuous total power dissipation		See <a href="#">Dissipation Rating Table</a>
T <sub>A</sub>	Operating free-air temperature range	–40°C to +85°C
T <sub>stg</sub>	Storage temperature range	–65°C to +150°C
Soldering temperature		+260°C

- (1) Stresses beyond those listed under *absolute maximum ratings* may cause permanent damage to the device. These are stress ratings only, and functional operation of the device at these or any other conditions beyond those indicated under *recommended operating conditions* is not implied. Exposure to absolute-maximum-rated conditions for extended periods may affect device reliability.
- (2) All voltage values are with respect to GND. For reliable operation the device should not be operated at 7 V for more than t = 1000h continuously.

### DISSIPATION RATING TABLE

PACKAGE	T <sub>A</sub> < +25°C POWER RATING	DERATING FACTOR ABOVE T <sub>A</sub> = +25°C	T <sub>A</sub> = +70°C POWER RATING	T <sub>A</sub> = +85°C POWER RATING
DBV	437 mW	3.5 mW/°C	280 mW	227 mW

## RECOMMENDED OPERATING CONDITIONS

At specified temperature range.

		MIN	MAX	UNIT
$V_{DD}$	Supply voltage	2	6	V
$V_I$	Input voltage	0	$V_{DD} + 0.3$	V
$V_{IH}$	High-level input voltage	$0.7 \times V_{DD}$		V
$V_{IL}$	Low-level input voltage		$0.3 \times V_{DD}$	V
$\Delta t/\Delta V$	Input transition rise and fall rate		100	ns/V
$t_w$	Pulse width of WDI trigger pulse	50		ns
$T_A$	Operating free-air temperature range	-40	+85	°C

## ELECTRICAL CHARACTERISTICS

Over recommended operating free-air temperature range (unless otherwise noted).

PARAMETER		TEST CONDITIONS	MIN	TYP	MAX	UNIT	
$V_{OL}$	Low-level output voltage	$V_{DD} = 2\text{ V to }6\text{ V}, I_{OL} = 500\ \mu\text{A}$			0.2	V	
		$V_{DD} = 3.3\text{ V}, I_{OL} = 2\text{ mA}$			0.4		
		$V_{DD} = 6\text{ V}, I_{OL} = 4\text{ mA}$			0.4		
Power up reset voltage <sup>(1)</sup>		$V_{DD} \geq 1.1\text{ V}, I_{OL} = 50\ \mu\text{A}$			0.2	V	
$V_{IT}$	Negative-going input threshold voltage <sup>(2)</sup>	$T_A = -40^\circ\text{C to }+85^\circ\text{C}$	TPS3813J25	2.2	2.25	2.3	V
			TPS3813L30	2.58	2.64	2.7	
			TPS3813K33	2.87	2.93	3	
			TPS3813I50	4.45	4.55	4.65	
$V_{hys}$	Hysteresis		TPS3813J25	30		mV	
			TPS3813L30	35			
			TPS3813K33	40			
			TPS3813I50	60			
$I_{IH}$	High-level input current	WDI, WDR	$WDI = V_{DD} = 6\text{ V}, WDR = V_{DD} = 6\text{ V}$		-25	25	nA
		WDT	$WDT = V_{DD} = 6\text{ V}, V_{DD} > V_{IT}, \overline{\text{RESET}} = \text{High}$		-100	100	
$I_{IL}$	Low-level input current	WDI, WDR	$WDI = 0\text{ V}, WDR = 0\text{ V}, V_{DD} = 6\text{ V}$		-25	25	nA
		WDT	$WDT = 0\text{ V}, V_{DD} > V_{IT}, \overline{\text{RESET}} = \text{High}$		-100	100	
$I_{OH}$	High-level output current		$V_{DD} = V_{IT} + 0.2\text{ V}, V_{OH} = V_{DD}$			25	nA
$I_{DD}$	Supply current		$V_{DD} = 2\text{ V output unconnected}$		9	13	$\mu\text{A}$
			$V_{DD} = 5\text{ V output unconnected}$		20	25	
$C_i$	Input capacitance		$V_I = 0\text{ V to }V_{DD}$		5		pF

 (1) The lowest supply voltage at which **RESET** becomes active.  $t_r, V_{DD} \geq 15\ \mu\text{s/V}$ .

 (2) To ensure best stability of the threshold voltage, a bypass capacitor (ceramic, 0.1  $\mu\text{F}$ ) should be placed near to the supply terminals.

### TIMING REQUIREMENTS

At  $R_L = 1\text{ M}\Omega$ ,  $C_L = 50\text{ pF}$ , and  $T_A = -40^\circ\text{C}$  to  $+85^\circ\text{C}$ .

PARAMETER	TEST CONDITIONS	MIN	TYP	MAX	UNIT
$t_w$ Pulse width at $V_{DD}$	$V_{DD} = V_{IT-} + 0.2\text{ V}$ , $V_{DD} = V_{IT-} - 0.2\text{ V}$	3			$\mu\text{s}$

### SWITCHING CHARACTERISTICS

At  $R_L = 1\text{ M}\Omega$ ,  $C_L = 50\text{ pF}$ , and  $T_A = -40^\circ\text{C}$  to  $+85^\circ\text{C}$ .

PARAMETER	TEST CONDITIONS	MIN	TYP	MAX	UNIT	
$t_d$ Delay time	$V_{DD} \geq V_{IT} + 0.2\text{ V}$ , See timing diagram	20	25	30	ms	
$t_{t(out)}$ Watchdog time-out	Upper limit					
	WDT = 0 V	0.2	0.25	0.3	s	
	WDT = $V_{DD}$	2	2.5	3		
Watchdog window ratio	WDT = programmable <sup>(1)</sup>		See <sup>(2)</sup>		ms	
	WDR = 0 V, WDT = 0 V		1:31.8			
	WDR = 0 V, WDT = $V_{DD}$		1:32			
	WDR = 0 V, WDT = programmable		1:25.8			
	WDR = $V_{DD}$ , WDT = 0 V		1:124.9			
	WDR = $V_{DD}$ , WDT = $V_{DD}$		1:127.7			
$t_{PHL}$ Propagation (delay) time, high-to-low-level output	$V_{DD}$ to $\overline{\text{RESET}}$ delay	$V_{IL} = V_{IT} - 0.2\text{ V}$ , $V_{IH} = V_{IT} + 0.2\text{ V}$		30	50	$\mu\text{s}$

(1)  $155\text{ pF} < C_{(ext)} < 63\text{ nF}$

(2)  $(C_{(ext)} \div 15.55\text{ pF} + 1) \times 6.25\text{ ms}$

**Table 1. TPS3813 FUNCTION/TRUTH TABLE**

$V_{DD} > V_{IT}$	RESET
0	L
1	H

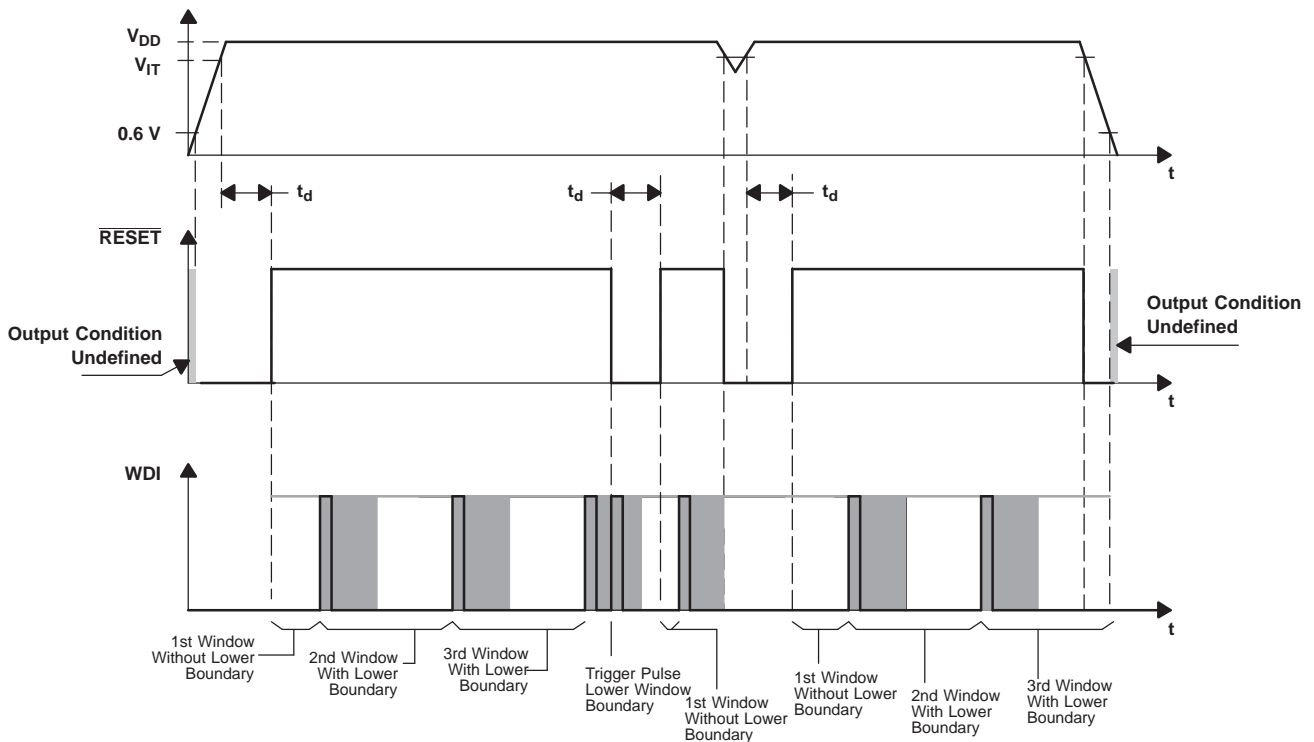
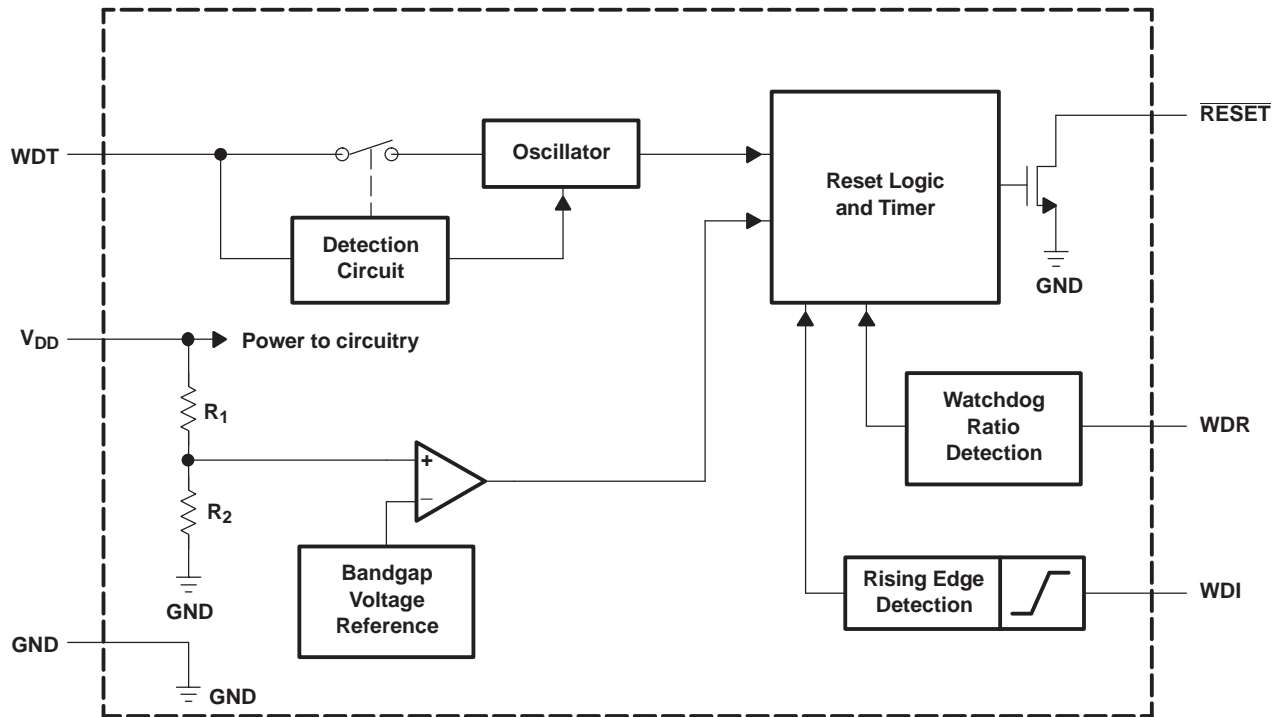

The lower boundary of the watchdog window starts with the rising edge of the WDI trigger pulse. At the same time, all internal timers will be reset. If an external capacitor is used, the lower boundary is impacted due to the different oscillator frequency. This is described in more detail in the following section. The timing diagram and especially the shaded boundary is prepared in a nonreal ratio scale to better visualize the description.

## PIN CONFIGURATIONS

DBV PACKAGE  
 SOT-6  
 (TOP VIEW)

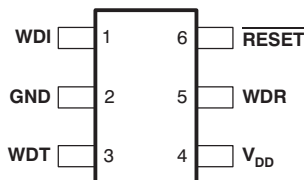

## Terminal Functions

TERMINAL NAME	NO.	I/O	DESCRIPTION
GND	2	I	Ground
RESET	6	O	Open-drain reset output
V <sub>DD</sub>	4	I	Supply voltage and supervising input
WDI	1	I	Watchdog timer input
WDR	5	I	Selectable watchdog window ratio input
WDT	3	I	Programmable watchdog delay input

## TYPICAL CHARACTERISTICS

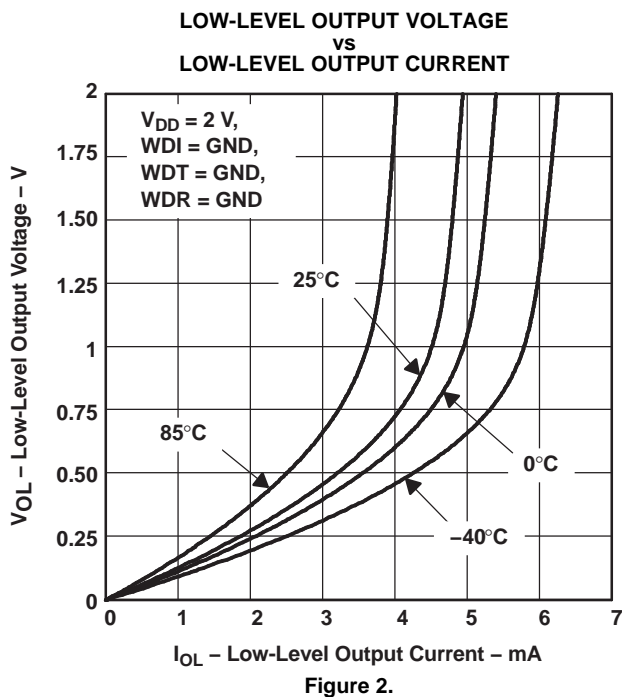
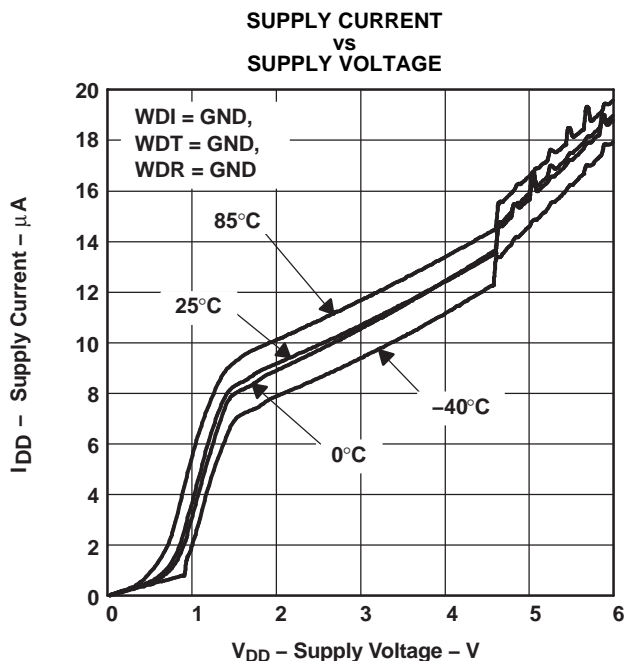

TYPICAL CHARACTERISTICS (continued)

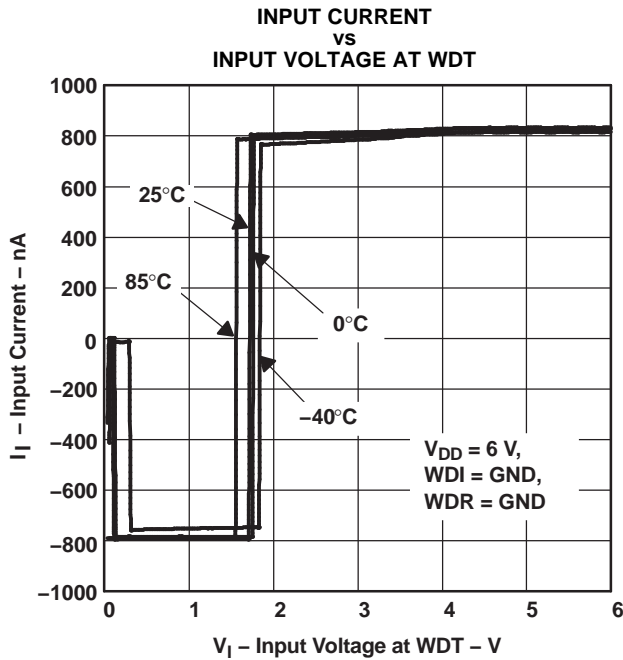

Figure 3.

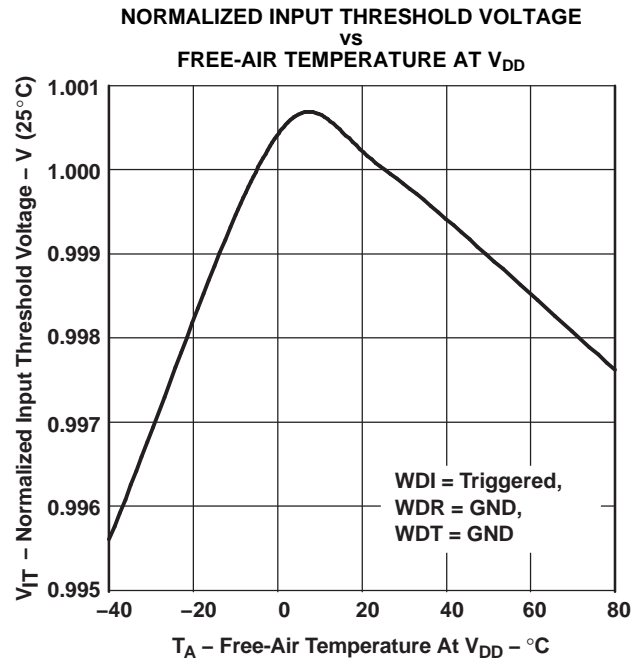

Figure 4.

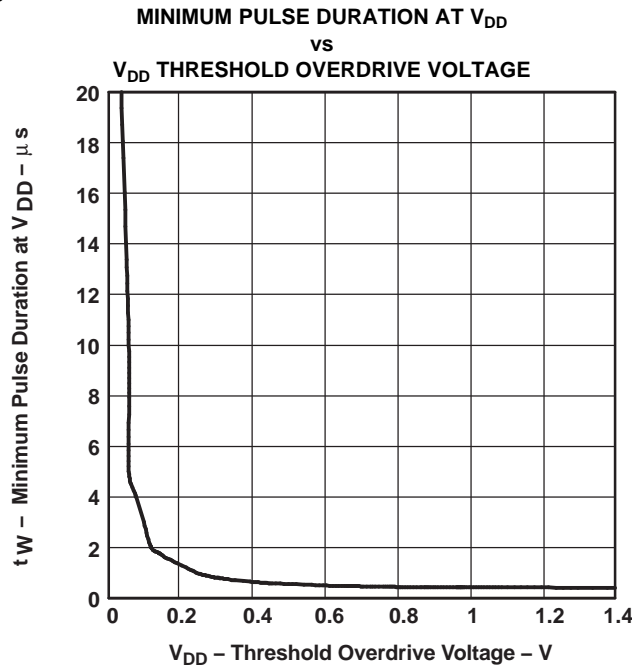

Figure 5.

## DETAILED DESCRIPTION

### IMPLEMENTED WINDOW-WATCHDOG SETTINGS

There are two different ways to set up the watchdog window. The first way is to use the implemented timing which is a default setting. Or, the default settings can be activated by wiring the WDT and WDR pin to  $V_{DD}$  or GND. There is a total of four different timings available with these settings. They are listed in the table below.

SELECTED OPERATION MODE		WINDOW FRAME	LOWER WINDOW FRAME
WDT = 0 V	WDR = 0 V	Max = 0.3 s	Max = 9.46 ms
		Typ = 0.25 s	Typ = 7.86 ms
		Min = 0.2 s	Min = 6.27 ms
	WDR = $V_{DD}$	Max = 0.3 s	Max = 2.43 ms
		Typ = 0.25 s	Typ = 2 ms
		Min = 0.2 s	Min = 1.58 ms
WDT = $V_{DD}$	WDR = 0 V	Max = 3 s	Max = 93.8 ms
		Typ = 2.5 s	Typ = 78.2 ms
		Min = 2 s	Min = 62.5 ms
	WDR = $V_{DD}$	Max = 3 s	Max = 23.5 ms
		Typ = 2.5 s	Typ = 19.6 ms
		Min = 2 s	Min = 15.6 ms

To visualize the values named in the table, a timing diagram was prepared. It is used to describe the upper and lower boundary settings. For an application, the important boundaries are the  $t_{\text{boundary,max}}$  and  $t_{\text{window,min}}$ . Within these values, the watchdog timer should be retriggered to avoid a timeout condition or a boundary violation in the event of a trigger pulse in the lower boundary. The values in the table above are typical and worst case conditions. They are valid over the whole temperature range of  $-40^{\circ}\text{C}$  to  $+85^{\circ}\text{C}$ .

In the shaded area of [Figure 6](#), it cannot be predicted if the device will detect a violation or not and release a reset. This is also the case between the boundary tolerance of  $t_{\text{boundary,min}}$  and  $t_{\text{boundary,max}}$  as well as between  $t_{\text{window,min}}$  and  $t_{\text{window,max}}$ . It is important to set up the trigger pulses accordingly to avoid violations in these areas.

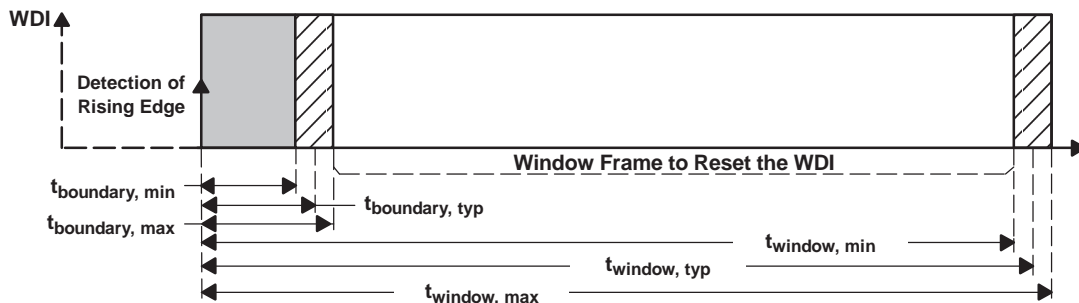

Figure 6. Upper and Lower Boundary Visualization

### TIMING RULES OF WINDOW-WATCHDOG

After the reset of the supervisor is released, the lower boundary of the first WDI window is disabled. However, after the first WDI pulse low-to-high transition is detected, the lower boundary function of the window is enabled. All further WDI pulses will need to fit into the configured window frame.



## PROGRAMMABLE WINDOW-WATCHDOG BY USING AN EXTERNAL CAPACITOR

The upper boundary of the watchdog timer can be set by an external capacitor connected between the WDT pin and GND. Common consumer electronic capacitors can be used to implement this feature. They should have low ESR and low tolerances since the tolerances have to be considered if the calculations are performed. The first formula is used to calculate the upper window frame. After calculating the upper window frame, the lower boundary can be calculated. As in the last example, the most important values are the  $t_{\text{boundary,max}}$  and  $t_{\text{window,min}}$ . The trigger pulse has to fit into this window frame.

The external capacitor should have a value between a minimum of 47 pF and a maximum of 63 nF.

SELECTED OPERATION MODE		WINDOW FRAME
WDT = external capacitor $C_{\text{(ext)}}$	WDR = 0 V and WDR = $V_{\text{DD}}$	$t_{\text{window,max}} = 1.25 \times t_{\text{window,typ}}$
		$t_{\text{window,min}} = 0.75 \times t_{\text{window,typ}}$

$$t_{\text{window,typ}} = \left( \frac{C_{\text{(ext)}}}{15.55 \text{ pF}} + 1 \right) \times 6.25 \text{ ms} \quad (1)$$

## LOWER BOUNDARY CALCULATION

The lower boundary can be calculated based on the values given in the switching characteristics. Additionally, facts have to be taken into account to verify that the lower boundary is where it is expected. Since the internal oscillator of the window watchdog is running free, any rising edge at the WDI pin will be taken into account at the next internal clock cycle. This happens regardless of the external source. Since the shift between internal and external clock is not known, it is best to consider the worst case condition for calculating this value.

SELECTED OPERATION MODE		LOWER BOUNDARY OF FRAME
WDT = external capacitor $C_{\text{(ext)}}$	WDR = 0 V	$t_{\text{boundary,max}} = t_{\text{window,max}} / 23.5$
		$t_{\text{boundary,typ}} = t_{\text{window,typ}} / 25.8$
		$t_{\text{boundary,min}} = t_{\text{window,min}} / 28.7$
	WDR = $V_{\text{DD}}$	$t_{\text{boundary,max}} = t_{\text{window,max}} / 51.6$
		$t_{\text{boundary,typ}} = t_{\text{window,typ}} / 64.5$
		$t_{\text{boundary,min}} = t_{\text{window,min}} / 92.7$

## WATCHDOG SOFTWARE CONSIDERATIONS

To benefit from the window watchdog feature and help the watchdog timer monitor the software execution more closely, it is recommended that the watchdog be set and reset at different points in the program rather than pulsing the watchdog input periodically by using the prescaler of a microcontroller or DSP. Furthermore, the watchdog trigger pulses should be set to different timings inside the window frame to release a defined reset, if the program should hang in any subroutine. This allows the window watchdog to detect timeouts of the trigger pulse as well as pulses that distort the lower boundary.

## APPLICATION EXAMPLE

A typical application example (see [Figure 7](#)) is used to describe the function of the watchdog in more detail.

To configure the window watchdog function, two pins are provided by the TPS3813. These pins set the window timeout and ratio.

The window watchdog ratio is a fixed ratio, which determines the lower boundary of the window frame. It can be configured in two different frame sizes.

If the window watchdog ratio pin (WDR) is set to  $V_{\text{DD}}$ , Position 1 in [Figure 7](#), then the lower window frame is a value based on a ratio calculation of the overall window timeout size: For the watchdog timeout pin (WDT) connected to GND, it is a ratio of 1:124.9, for WDT connected to  $V_{\text{DD}}$ , it is a ratio of 1:127.7, and for an external capacitor connected to WDT, it is a ratio of 1:64.5.

If the window watchdog ratio pin (WDR) is set to GND, Position 2, the lower window frame will be a value based on a ratio calculation of the overall window timeout size: For the watchdog timeout pin (WDT) connected to GND, it will be a ratio of 1:31.8, for WDT connected to  $V_{DD}$  it will be 1:32, and for an external capacitor connected to WDT it will be 1:25.8.

The watchdog timeout can be set in two fixed timings of 0.25 seconds and 2.5 seconds for the window or can be programmed by connecting an external capacitor with a low leakage current at WDT.

Example: If the watchdog timeout pin (WDT) is connected to  $V_{DD}$ , the timeout will be 2.5 seconds. If the window watchdog ratio pin (WDR) is set in this configuration to a ratio of 1:127.7 by connecting the pin to  $V_{DD}$ , the lower boundary is 19.6 ms.

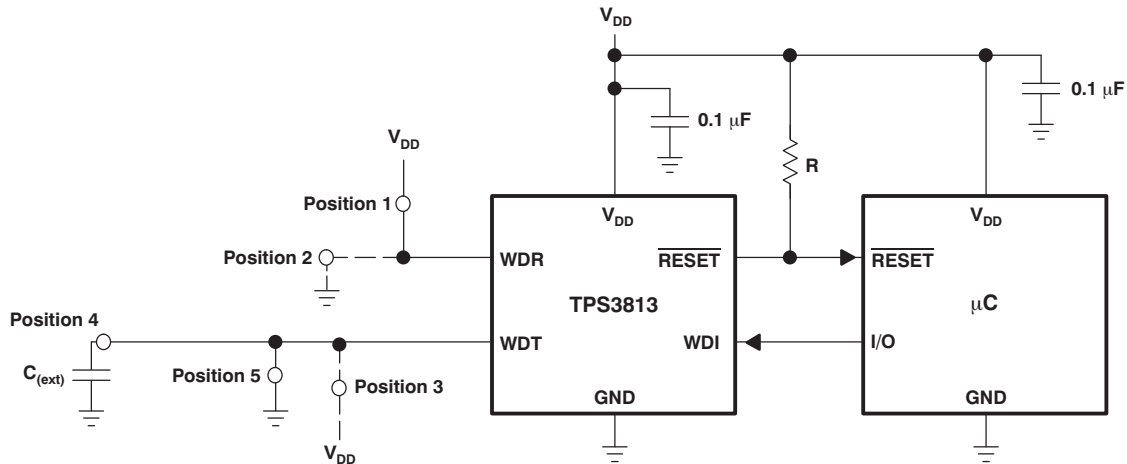

Figure 7. Application Example

**PACKAGING INFORMATION**

Orderable Device	Status <sup>(1)</sup>	Package Type	Package Drawing	Pins	Package Qty	Eco Plan <sup>(2)</sup>	Lead/Ball Finish	MSL Peak Temp <sup>(3)</sup>
TPS3813I50DBVR	ACTIVE	SOT-23	DBV	6	3000	Green (RoHS & no Sb/Br)	CU NIPDAU	Level-1-260C-UNLIM
TPS3813I50DBVRG4	ACTIVE	SOT-23	DBV	6	3000	Green (RoHS & no Sb/Br)	CU NIPDAU	Level-1-260C-UNLIM
TPS3813I50DBVT	ACTIVE	SOT-23	DBV	6	250	Green (RoHS & no Sb/Br)	CU NIPDAU	Level-1-260C-UNLIM
TPS3813I50DBVTG4	ACTIVE	SOT-23	DBV	6	250	Green (RoHS & no Sb/Br)	CU NIPDAU	Level-1-260C-UNLIM
TPS3813J25DBVR	ACTIVE	SOT-23	DBV	6	3000	Green (RoHS & no Sb/Br)	CU NIPDAU	Level-1-260C-UNLIM
TPS3813J25DBVRG4	ACTIVE	SOT-23	DBV	6	3000	Green (RoHS & no Sb/Br)	CU NIPDAU	Level-1-260C-UNLIM
TPS3813J25DBVT	ACTIVE	SOT-23	DBV	6	250	Green (RoHS & no Sb/Br)	CU NIPDAU	Level-1-260C-UNLIM
TPS3813J25DBVTG4	ACTIVE	SOT-23	DBV	6	250	Green (RoHS & no Sb/Br)	CU NIPDAU	Level-1-260C-UNLIM
TPS3813K33DBVR	ACTIVE	SOT-23	DBV	6	3000	Green (RoHS & no Sb/Br)	CU NIPDAU	Level-1-260C-UNLIM
TPS3813K33DBVRG4	ACTIVE	SOT-23	DBV	6	3000	Green (RoHS & no Sb/Br)	CU NIPDAU	Level-1-260C-UNLIM
TPS3813K33DBVT	ACTIVE	SOT-23	DBV	6	250	Green (RoHS & no Sb/Br)	CU NIPDAU	Level-1-260C-UNLIM
TPS3813K33DBVTG4	ACTIVE	SOT-23	DBV	6	250	Green (RoHS & no Sb/Br)	CU NIPDAU	Level-1-260C-UNLIM
TPS3813L30DBVR	ACTIVE	SOT-23	DBV	6	3000	Green (RoHS & no Sb/Br)	CU NIPDAU	Level-1-260C-UNLIM
TPS3813L30DBVRG4	ACTIVE	SOT-23	DBV	6	3000	Green (RoHS & no Sb/Br)	CU NIPDAU	Level-1-260C-UNLIM
TPS3813L30DBVT	ACTIVE	SOT-23	DBV	6	250	Green (RoHS & no Sb/Br)	CU NIPDAU	Level-1-260C-UNLIM
TPS3813L30DBVTG4	ACTIVE	SOT-23	DBV	6	250	Green (RoHS & no Sb/Br)	CU NIPDAU	Level-1-260C-UNLIM

<sup>(1)</sup> The marketing status values are defined as follows:

**ACTIVE:** Product device recommended for new designs.

**LIFEBUY:** TI has announced that the device will be discontinued, and a lifetime-buy period is in effect.

**NRND:** Not recommended for new designs. Device is in production to support existing customers, but TI does not recommend using this part in a new design.

**PREVIEW:** Device has been announced but is not in production. Samples may or may not be available.

**OBSOLETE:** TI has discontinued the production of the device.

<sup>(2)</sup> Eco Plan - The planned eco-friendly classification: Pb-Free (RoHS), Pb-Free (RoHS Exempt), or Green (RoHS & no Sb/Br) - please check <http://www.ti.com/productcontent> for the latest availability information and additional product content details.

**TBD:** The Pb-Free/Green conversion plan has not been defined.

**Pb-Free (RoHS):** TI's terms "Lead-Free" or "Pb-Free" mean semiconductor products that are compatible with the current RoHS requirements for all 6 substances, including the requirement that lead not exceed 0.1% by weight in homogeneous materials. Where designed to be soldered at high temperatures, TI Pb-Free products are suitable for use in specified lead-free processes.

**Pb-Free (RoHS Exempt):** This component has a RoHS exemption for either 1) lead-based flip-chip solder bumps used between the die and package, or 2) lead-based die adhesive used between the die and leadframe. The component is otherwise considered Pb-Free (RoHS compatible) as defined above.

**Green (RoHS & no Sb/Br):** TI defines "Green" to mean Pb-Free (RoHS compatible), and free of Bromine (Br) and Antimony (Sb) based flame retardants (Br or Sb do not exceed 0.1% by weight in homogeneous material)

(3) MSL, Peak Temp. -- The Moisture Sensitivity Level rating according to the JEDEC industry standard classifications, and peak solder temperature.

**Important Information and Disclaimer:**The information provided on this page represents TI's knowledge and belief as of the date that it is provided. TI bases its knowledge and belief on information provided by third parties, and makes no representation or warranty as to the accuracy of such information. Efforts are underway to better integrate information from third parties. TI has taken and continues to take reasonable steps to provide representative and accurate information but may not have conducted destructive testing or chemical analysis on incoming materials and chemicals. TI and TI suppliers consider certain information to be proprietary, and thus CAS numbers and other limited information may not be available for release.

In no event shall TI's liability arising out of such information exceed the total purchase price of the TI part(s) at issue in this document sold by TI to Customer on an annual basis.

**OTHER QUALIFIED VERSIONS OF TPS3813I50, TPS3813K33 :**

- Automotive: [TPS3813I50-Q1](#)
- Enhanced Product: [TPS3813K33-EP](#)

**NOTE: Qualified Version Definitions:**

- Automotive - Q100 devices qualified for high-reliability automotive applications targeting zero defects
- Enhanced Product - Supports Defense, Aerospace and Medical Applications

**TAPE AND REEL INFORMATION**



**QUADRANT ASSIGNMENTS FOR PIN 1 ORIENTATION IN TAPE**



\*All dimensions are nominal

Device	Package Type	Package Drawing	Pins	SPQ	Reel Diameter (mm)	Reel Width W1 (mm)	A0 (mm)	B0 (mm)	K0 (mm)	P1 (mm)	W (mm)	Pin1 Quadrant
TPS3813I50DBVR	SOT-23	DBV	6	3000	179.0	8.4	3.2	3.2	1.4	4.0	8.0	Q3
TPS3813I50DBVR	SOT-23	DBV	6	3000	180.0	9.0	3.15	3.2	1.4	4.0	8.0	Q3
TPS3813I50DBVT	SOT-23	DBV	6	250	179.0	8.4	3.2	3.2	1.4	4.0	8.0	Q3
TPS3813I50DBVT	SOT-23	DBV	6	250	180.0	9.0	3.15	3.2	1.4	4.0	8.0	Q3
TPS3813J25DBVR	SOT-23	DBV	6	3000	180.0	9.0	3.15	3.2	1.4	4.0	8.0	Q3
TPS3813J25DBVR	SOT-23	DBV	6	3000	179.0	8.4	3.2	3.2	1.4	4.0	8.0	Q3
TPS3813J25DBVT	SOT-23	DBV	6	250	179.0	8.4	3.2	3.2	1.4	4.0	8.0	Q3
TPS3813J25DBVT	SOT-23	DBV	6	250	180.0	9.0	3.15	3.2	1.4	4.0	8.0	Q3
TPS3813K33DBVR	SOT-23	DBV	6	3000	180.0	9.0	3.15	3.2	1.4	4.0	8.0	Q3
TPS3813K33DBVR	SOT-23	DBV	6	3000	179.0	8.4	3.2	3.2	1.4	4.0	8.0	Q3
TPS3813K33DBVT	SOT-23	DBV	6	250	180.0	9.0	3.15	3.2	1.4	4.0	8.0	Q3
TPS3813K33DBVT	SOT-23	DBV	6	250	179.0	8.4	3.2	3.2	1.4	4.0	8.0	Q3
TPS3813L30DBVR	SOT-23	DBV	6	3000	180.0	9.0	3.15	3.2	1.4	4.0	8.0	Q3
TPS3813L30DBVR	SOT-23	DBV	6	3000	179.0	8.4	3.2	3.2	1.4	4.0	8.0	Q3
TPS3813L30DBVT	SOT-23	DBV	6	250	179.0	8.4	3.2	3.2	1.4	4.0	8.0	Q3
TPS3813L30DBVT	SOT-23	DBV	6	250	180.0	9.0	3.15	3.2	1.4	4.0	8.0	Q3

**TAPE AND REEL BOX DIMENSIONS**

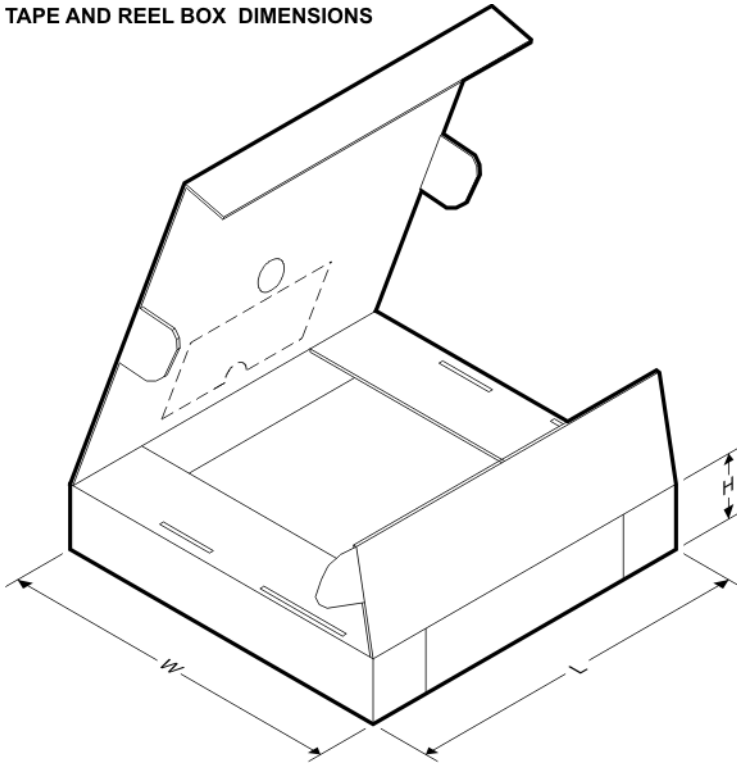

\*All dimensions are nominal

Device	Package Type	Package Drawing	Pins	SPQ	Length (mm)	Width (mm)	Height (mm)
TPS3813I50DBVR	SOT-23	DBV	6	3000	195.0	200.0	45.0
TPS3813I50DBVR	SOT-23	DBV	6	3000	182.0	182.0	20.0
TPS3813I50DBVT	SOT-23	DBV	6	250	195.0	200.0	45.0
TPS3813I50DBVT	SOT-23	DBV	6	250	182.0	182.0	20.0
TPS3813J25DBVR	SOT-23	DBV	6	3000	182.0	182.0	20.0
TPS3813J25DBVR	SOT-23	DBV	6	3000	195.0	200.0	45.0
TPS3813J25DBVT	SOT-23	DBV	6	250	195.0	200.0	45.0
TPS3813J25DBVT	SOT-23	DBV	6	250	182.0	182.0	20.0
TPS3813K33DBVR	SOT-23	DBV	6	3000	182.0	182.0	20.0
TPS3813K33DBVR	SOT-23	DBV	6	3000	195.0	200.0	45.0
TPS3813K33DBVT	SOT-23	DBV	6	250	182.0	182.0	20.0
TPS3813K33DBVT	SOT-23	DBV	6	250	195.0	200.0	45.0
TPS3813L30DBVR	SOT-23	DBV	6	3000	182.0	182.0	20.0
TPS3813L30DBVR	SOT-23	DBV	6	3000	195.0	200.0	45.0
TPS3813L30DBVT	SOT-23	DBV	6	250	195.0	200.0	45.0
TPS3813L30DBVT	SOT-23	DBV	6	250	182.0	182.0	20.0

DBV (R-PDSO-G6)

PLASTIC SMALL-OUTLINE PACKAGE

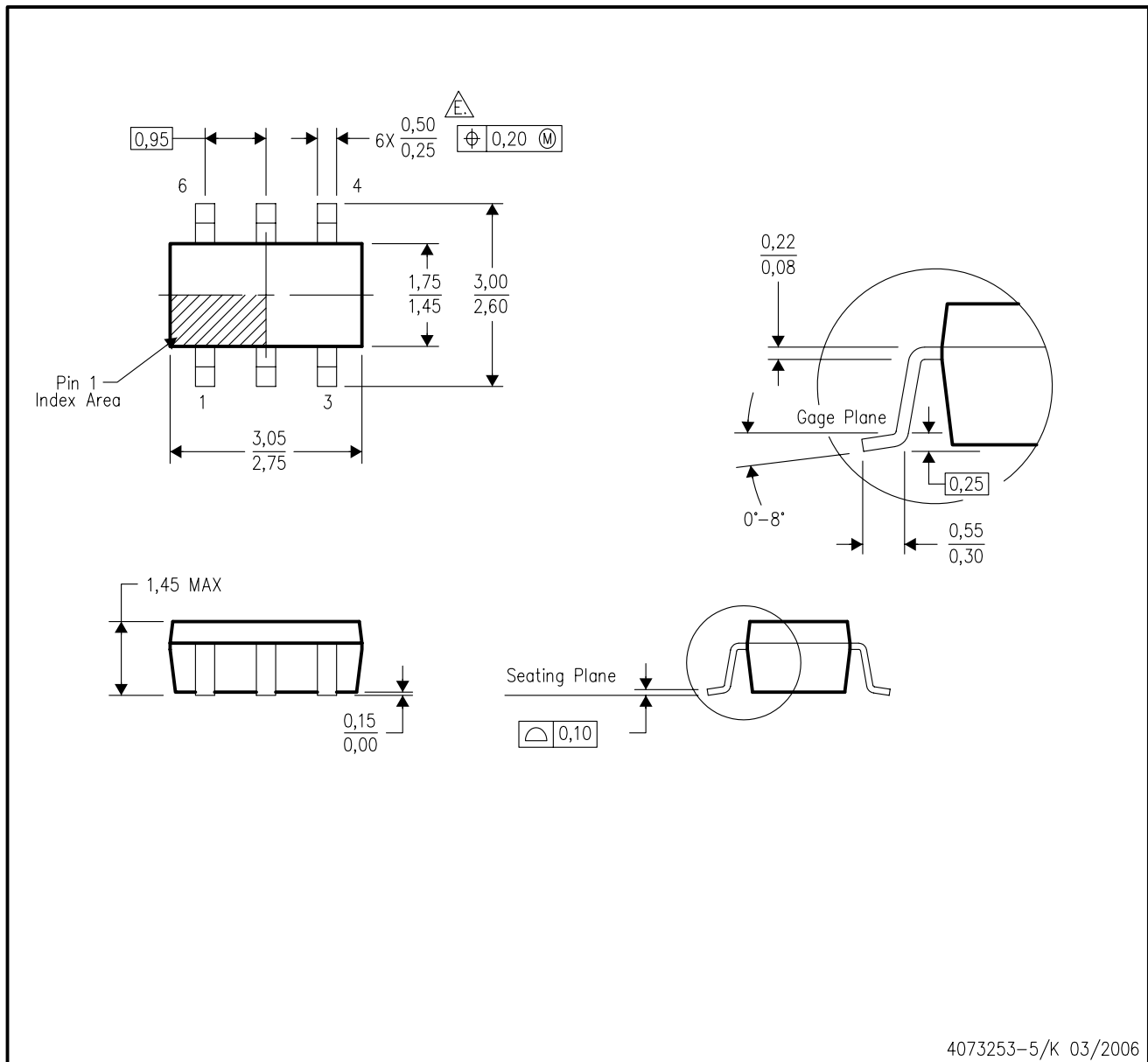

- NOTES:
- A. All linear dimensions are in millimeters.
  - B. This drawing is subject to change without notice.
  - C. Body dimensions do not include mold flash or protrusion. Mold flash and protrusion shall not exceed 0.15 per side.
  - D. Leads 1,2,3 may be wider than leads 4,5,6 for package orientation.
- $\triangle$  Falls within JEDEC MO-178 Variation AB, except minimum lead width.

DBV (R-PDSO-G6)

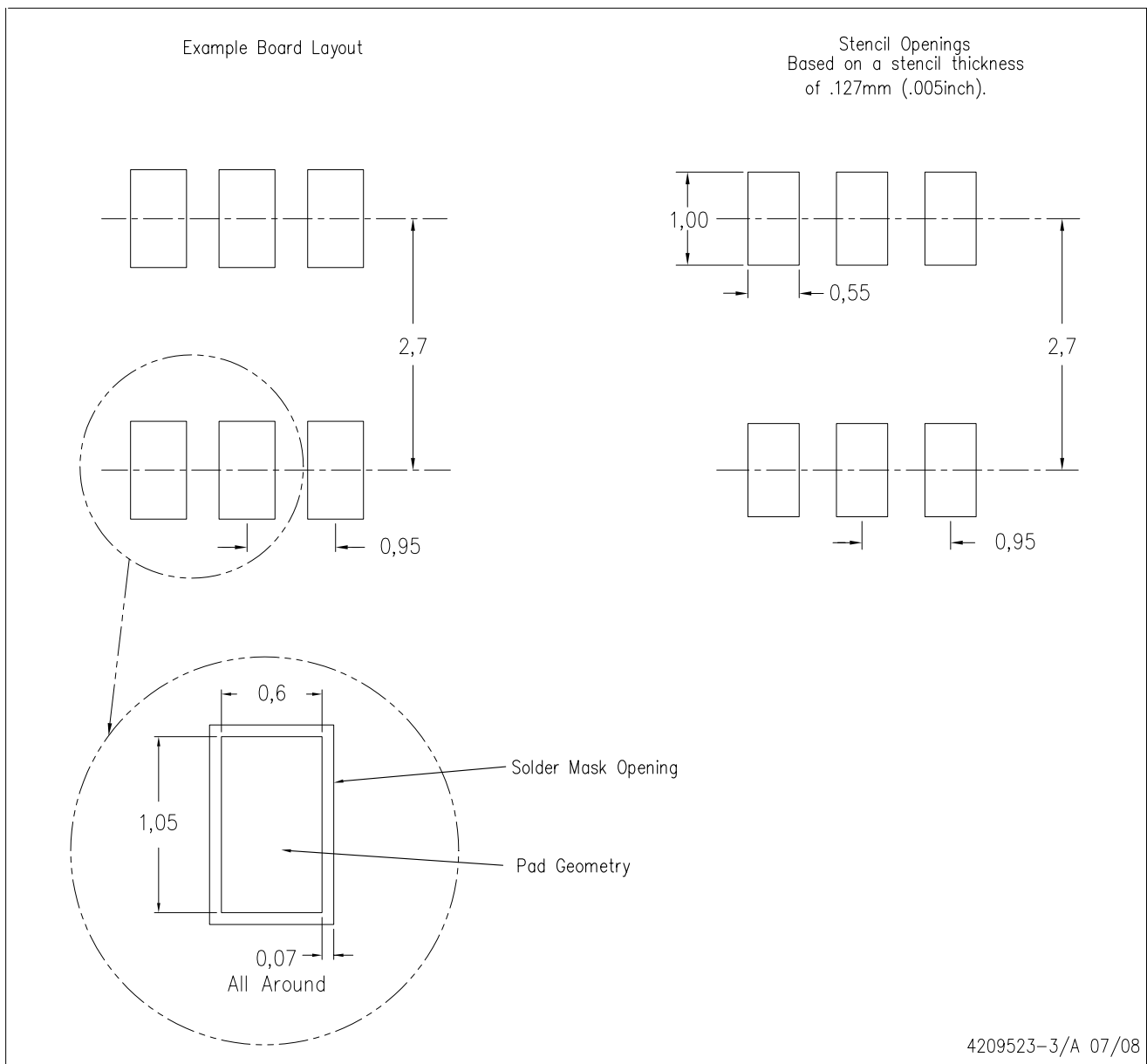

- NOTES:
- A. All linear dimensions are in millimeters.
  - B. This drawing is subject to change without notice.
  - C. Customers should place a note on the circuit board fabrication drawing not to alter the center solder mask defined pad.
  - D. Publication IPC-7351 is recommended for alternate designs.
  - E. Laser cutting apertures with trapezoidal walls and also rounding corners will offer better paste release. Customers should contact their board assembly site for stencil design recommendations. Example stencil design based on a 50% volumetric metal load solder paste. Refer to IPC-7525 for other stencil recommendations.



DBV (R-PDSO-G6)

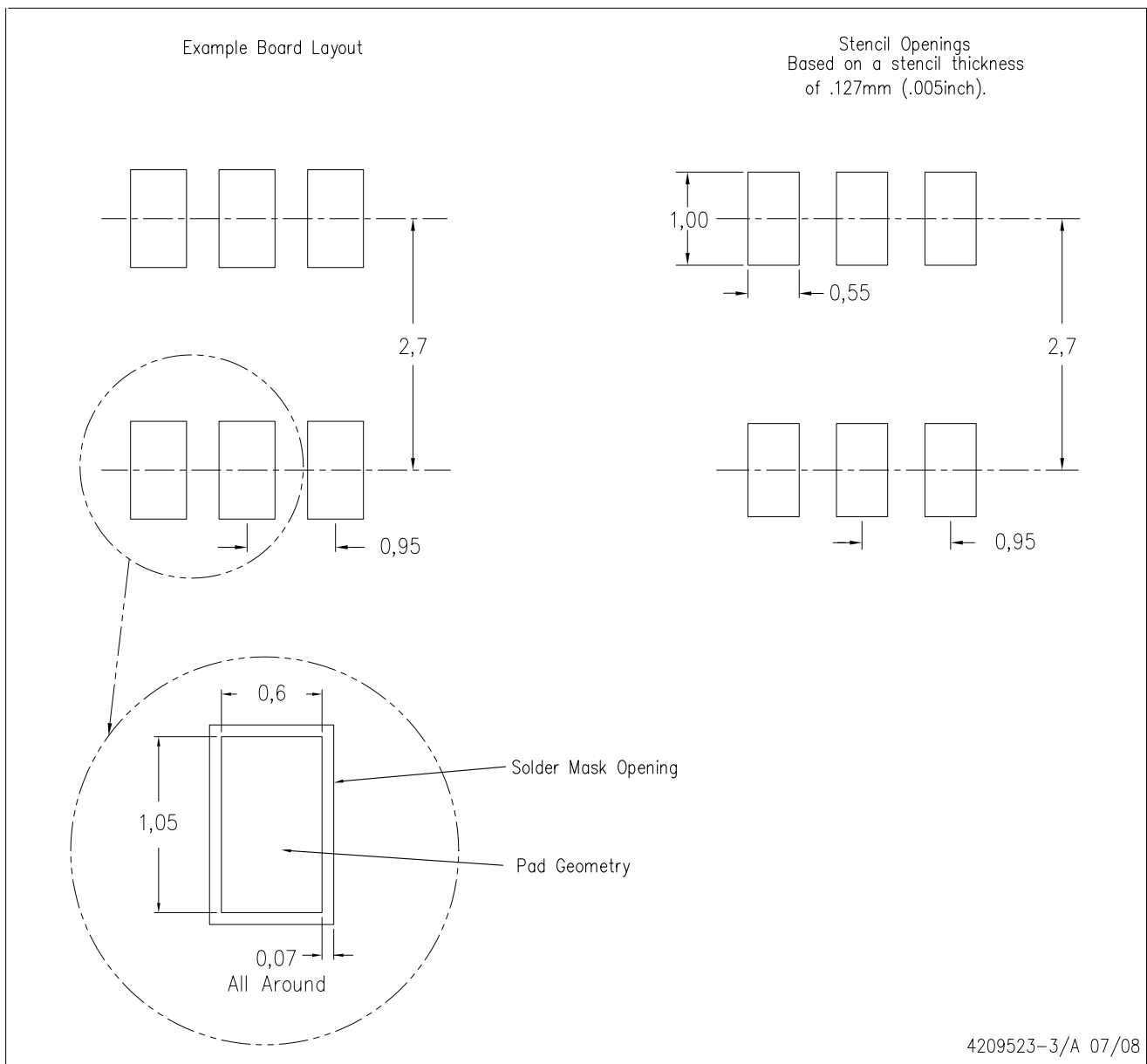

- NOTES:
- A. All linear dimensions are in millimeters.
  - B. This drawing is subject to change without notice.
  - C. Customers should place a note on the circuit board fabrication drawing not to alter the center solder mask defined pad.
  - D. Publication IPC-7351 is recommended for alternate designs.
  - E. Laser cutting apertures with trapezoidal walls and also rounding corners will offer better paste release. Customers should contact their board assembly site for stencil design recommendations. Example stencil design based on a 50% volumetric metal load solder paste. Refer to IPC-7525 for other stencil recommendations.

## IMPORTANT NOTICE

Texas Instruments Incorporated and its subsidiaries (TI) reserve the right to make corrections, modifications, enhancements, improvements, and other changes to its products and services at any time and to discontinue any product or service without notice. Customers should obtain the latest relevant information before placing orders and should verify that such information is current and complete. All products are sold subject to TI's terms and conditions of sale supplied at the time of order acknowledgment.

TI warrants performance of its hardware products to the specifications applicable at the time of sale in accordance with TI's standard warranty. Testing and other quality control techniques are used to the extent TI deems necessary to support this warranty. Except where mandated by government requirements, testing of all parameters of each product is not necessarily performed.

TI assumes no liability for applications assistance or customer product design. Customers are responsible for their products and applications using TI components. To minimize the risks associated with customer products and applications, customers should provide adequate design and operating safeguards.

TI does not warrant or represent that any license, either express or implied, is granted under any TI patent right, copyright, mask work right, or other TI intellectual property right relating to any combination, machine, or process in which TI products or services are used. Information published by TI regarding third-party products or services does not constitute a license from TI to use such products or services or a warranty or endorsement thereof. Use of such information may require a license from a third party under the patents or other intellectual property of the third party, or a license from TI under the patents or other intellectual property of TI.

Reproduction of TI information in TI data books or data sheets is permissible only if reproduction is without alteration and is accompanied by all associated warranties, conditions, limitations, and notices. Reproduction of this information with alteration is an unfair and deceptive business practice. TI is not responsible or liable for such altered documentation. Information of third parties may be subject to additional restrictions.

Resale of TI products or services with statements different from or beyond the parameters stated by TI for that product or service voids all express and any implied warranties for the associated TI product or service and is an unfair and deceptive business practice. TI is not responsible or liable for any such statements.

TI products are not authorized for use in safety-critical applications (such as life support) where a failure of the TI product would reasonably be expected to cause severe personal injury or death, unless officers of the parties have executed an agreement specifically governing such use. Buyers represent that they have all necessary expertise in the safety and regulatory ramifications of their applications, and acknowledge and agree that they are solely responsible for all legal, regulatory and safety-related requirements concerning their products and any use of TI products in such safety-critical applications, notwithstanding any applications-related information or support that may be provided by TI. Further, Buyers must fully indemnify TI and its representatives against any damages arising out of the use of TI products in such safety-critical applications.

TI products are neither designed nor intended for use in military/aerospace applications or environments unless the TI products are specifically designated by TI as military-grade or "enhanced plastic." Only products designated by TI as military-grade meet military specifications. Buyers acknowledge and agree that any such use of TI products which TI has not designated as military-grade is solely at the Buyer's risk, and that they are solely responsible for compliance with all legal and regulatory requirements in connection with such use.

TI products are neither designed nor intended for use in automotive applications or environments unless the specific TI products are designated by TI as compliant with ISO/TS 16949 requirements. Buyers acknowledge and agree that, if they use any non-designated products in automotive applications, TI will not be responsible for any failure to meet such requirements.

Following are URLs where you can obtain information on other Texas Instruments products and application solutions:

### Products

Amplifiers	<a href="http://amplifier.ti.com">amplifier.ti.com</a>
Data Converters	<a href="http://dataconverter.ti.com">dataconverter.ti.com</a>
DLP® Products	<a href="http://www.dlp.com">www.dlp.com</a>
DSP	<a href="http://dsp.ti.com">dsp.ti.com</a>
Clocks and Timers	<a href="http://www.ti.com/clocks">www.ti.com/clocks</a>
Interface	<a href="http://interface.ti.com">interface.ti.com</a>
Logic	<a href="http://logic.ti.com">logic.ti.com</a>
Power Mgmt	<a href="http://power.ti.com">power.ti.com</a>
Microcontrollers	<a href="http://microcontroller.ti.com">microcontroller.ti.com</a>
RFID	<a href="http://www.ti-rfid.com">www.ti-rfid.com</a>
RF/IF and ZigBee® Solutions	<a href="http://www.ti.com/lprf">www.ti.com/lprf</a>

### Applications

Audio	<a href="http://www.ti.com/audio">www.ti.com/audio</a>
Automotive	<a href="http://www.ti.com/automotive">www.ti.com/automotive</a>
Broadband	<a href="http://www.ti.com/broadband">www.ti.com/broadband</a>
Digital Control	<a href="http://www.ti.com/digitalcontrol">www.ti.com/digitalcontrol</a>
Medical	<a href="http://www.ti.com/medical">www.ti.com/medical</a>
Military	<a href="http://www.ti.com/military">www.ti.com/military</a>
Optical Networking	<a href="http://www.ti.com/opticalnetwork">www.ti.com/opticalnetwork</a>
Security	<a href="http://www.ti.com/security">www.ti.com/security</a>
Telephony	<a href="http://www.ti.com/telephony">www.ti.com/telephony</a>
Video & Imaging	<a href="http://www.ti.com/video">www.ti.com/video</a>
Wireless	<a href="http://www.ti.com/wireless">www.ti.com/wireless</a>

Mailing Address: Texas Instruments, Post Office Box 655303, Dallas, Texas 75265  
Copyright © 2009, Texas Instruments Incorporated