



# TR90

## MAIN FEATURES

- Up to 30A switching in SPST and 20A switching in spot arrangements.
- Available as an open-frame relay, with a snap-on dust cover or with an immersion cleanable, plastic sealed case.
- Meet UL F Insulation class.



## APPLICATIONS

- Used for power switching, Electrical Heater, ventilator, Air conditioning, Refrigerating, Automobile and House-hold Appliance.

## ORDERING INFORMATION

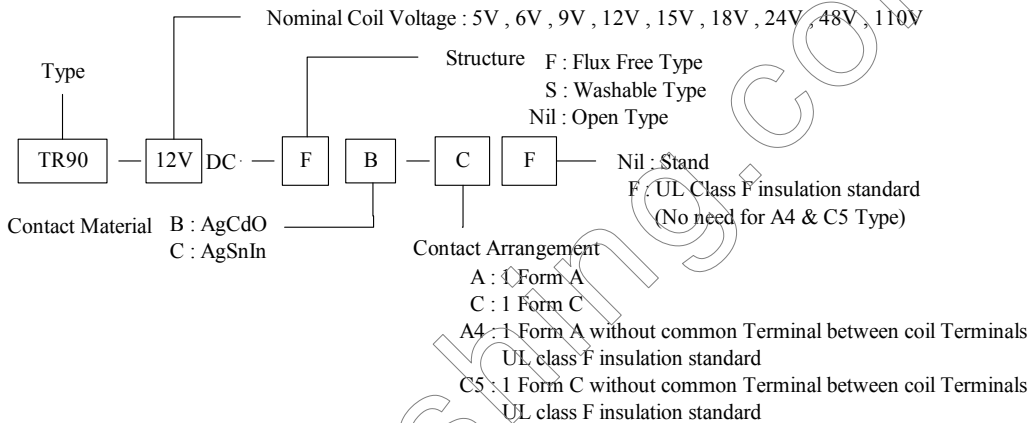

## DIMENSION (unit:mm)

## DRILLING (unit:mm)

## WIRING DIAGRAM

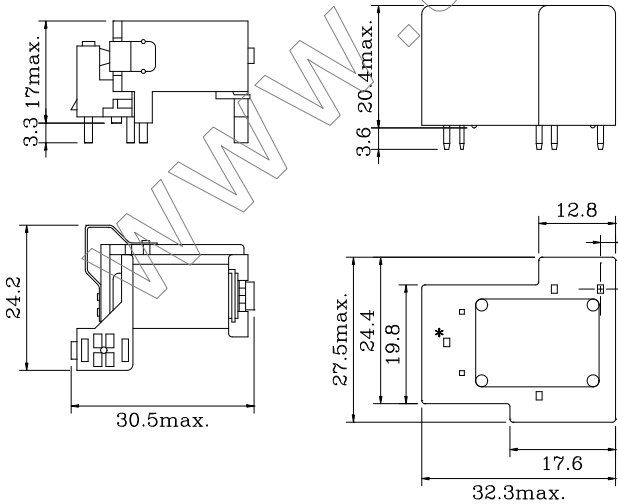

TR90-A &TR90-C (For UL 508)

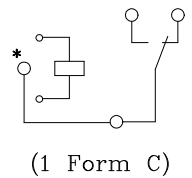
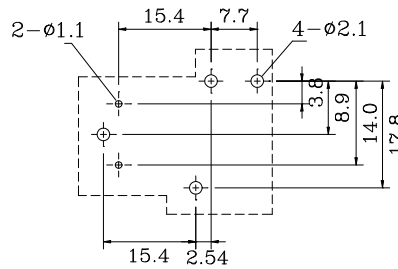

TR90-A4 &TR90-C5 (For UL 873)

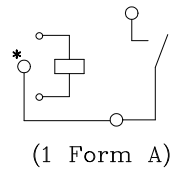
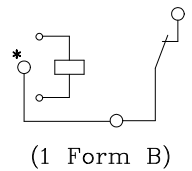
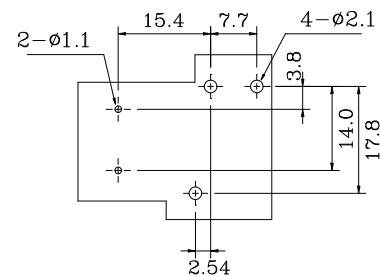

NOTE : “ \* ” This Terminal not present for A4 & C5 Type ( MEET UL873 Spacing ).

## ■ COIL DATA CHART (AT20°C)

Coil Sensitivity	Coil Voltage Code	Nominal Voltage (VDC)	Nominal Current (mA)	Coil Resistance ( $\Omega$ ) $\pm 10\%$	Power Consumption (W)	Pull-In Voltage (VDC)	Drop-Out Voltage (VDC)	Max-Allowable Voltage (VDC)
TR90	05	5	185	27	abt. 0.93W	80% Max.	10% Max.	120%Max.
	06	6	150	40				
	09	9	93	97				
	12	12	77	155				
	15	15	59	256				
	18	18	47	380				
	24	24	36	660				
	48	48	19	2560				
	110	110	8	13450 $\pm 15\%$				

## ■ CONTACT RATING

Item	Type	TR90			
		FORM A	FORM B	FORM C	
				N/O	N/C
Resistive Load (cos $\Phi$ =1)		30A 240VAC 30A 28VDC	15A 240VAC 10A 28VDC	20A 240VAC 20A 28VDC	10A 240VAC 10A 28VDC
General Motor		240VAC 2HP 120VAC 1HP	240VAC 0.5HP 120VAC 0.25HP	240VAC 2HP 120VAC 1HP	240VAC 0.5HP 120VAC 0.25HP
Tungsten		TV-5	TV-3	TV-5	TV-3
Ballast		10A 277VAC	3A 277VAC	10A 277VAC	3A 277VAC
LRA/FLA		240VAC 80/30	240VAC 30/10	240VAC 50/20	240VAC 20/7

## ■ REFERENCE DATA

### OPEN-STYLE RELAY, NO DUST COVER

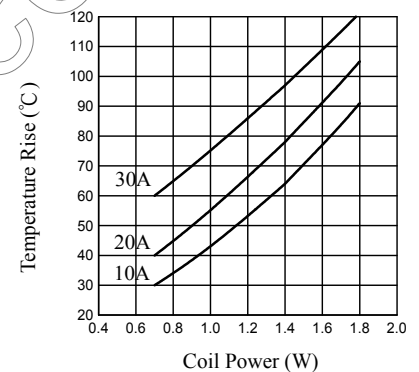

## ■ PERFORMANCE (at initial value)

Item	Type	TR90	
		UL508	UL873
Contact Resistance		100m $\Omega$ Max.	
Operation Time		15msec Max.	
Release Time		10msec Max.	
Dielectric Strength		2500VAC	
Between coil & contact		1500VAC 50/60HZ (1 minute)	
Between contacts		1500VAC	
Insulation Resistance		10 M $\Omega$ Min. (500VDC)	
Max. ON/OFF Switching			
Mechanically		300 operation/min	
Electrically		30 operation/min	
Operating Ambient Temperature		-55° to +85°C (operating) with UL approval -55° to +105°C (operating) without UL approval -55° to +155°C (storage)	
Operating Humidity		45 to 85% RH	
Coil Temperature Rise		60 deg. Max.	
Vibration			
Endurance		10 to 55Hz Double Amplitude 1.5mm	
Error Operation		10 to 55Hz Double Amplitude 1.5mm	
Shock			
Endurance		100 m/sec <sup>2</sup> (abt. 100g's)	
Error Operation		10 m/sec <sup>2</sup> (abt. 10g's)	
Life Expectancy			
Mechanically		10 $\times$ 10 <sup>6</sup>	
Electrically		10 $\times$ 10 <sup>4</sup>	
Weight		abt. 22grs, 28grs (SEALED)	
UL File No.		E156406	
CSA File No.		LR700159	

### SEALED RELAY

