



# TRU

TRUT with TV-5 Approval

### MAIN FEATURES

- High contact capacity : 12A, (15A for TUV approved)
- UL/CSA, TUV recognized. TRUT (TV-5 Approved).
- Employment of suitable plastic materials to be applied to high temperature and various chemical solution.
- Sealed types available.



### APPLICATIONS

- TRU :
- Home appliance, air conditioner, heater, etc.
  - Automotive Power-window, car antenna, door-lock, etc.
  - Office machine, facsimile, etc.
  - Vending machine.
- TRUT :
- Remote control TV receivers, monitor displays, audio equipment high rushing current use application.

### ORDERING INFORMATION

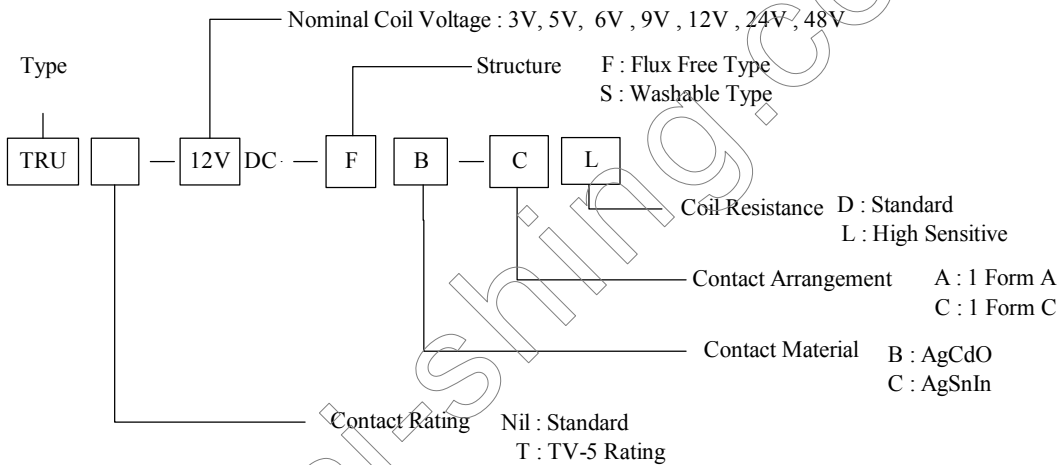

### DIMENSION(unit:mm)

### DRILLING(unit:mm)

### WIRING DIAGRAM

TRU 1 Form A AND TRUT(TV-5)

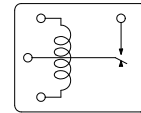
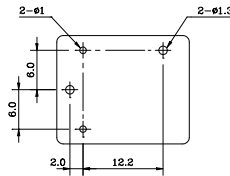
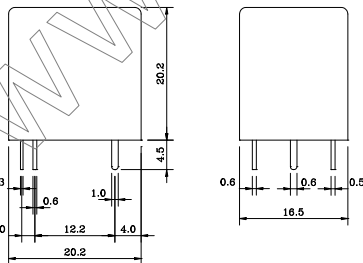

TRU 1 Form C

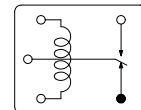
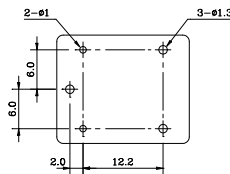
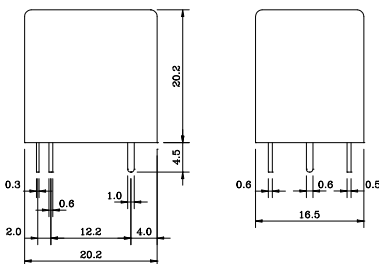

## COIL DATA CHART (AT20°C)

Coil Sensitivity	Coil Voltage Code	Nominal Voltage (VDC)	Nominal Current (mA)	Coil Resistance ( $\Omega$ ) $\pm 10\%$	Power Consumption (W)	Pull-In Voltage (VDC)	Drop-Out Voltage (VDC)	Max-Allowable Voltage (VDC)
TRU (High Sensitivity)	03	03	120	25	abt. 0.36W	75% Max.	5% Min.	130%
	05	05	71.5	70				
	06	06	60	100				
	09	09	40	225				
	12	12	30	400				
	24	24	15	1600				
TRU (Standard)	03	03	150	20	abt. 0.45W	75% Max.	5% Min.	130%
	05	05	89.3	56				
	06	06	75	80				
	09	09	50	180				
	12	12	37.5	320				
	24	24	18.7	1280				
	48	48	10	4500	abt. 0.51W			

## CONTACT RATING

Item	Type	TRU		TRUT TV-5
		12A	15A	
Contact Capacity		12A 28VDC	12A 28VDC	15A 28VDC
Resistive Load ( $\cos\Phi=1$ )		12A 120VAC 10A 250VAC	15A 125VAC 10A 250VAC	15A 125VAC 10A 250VAC
Inductive Load ( $\cos\Phi=0.4$ L/R=7msec)		5A 240VAC 5A 28VDC	7A 120VAC 7A 28VDC	120VAC TV-5 Incandescent Lamp 5A Rush Current 80A
Rated Carrying Current		12A	15A	15A
Max. Allowable Voltage		250VAC, 110VDC	250VAC, 110VDC	250VAC, 110VDC
Max. Allowable Current		12A	15A	15A
Max. Allowable Power Force		1500VA/350W	1800VA/420W	1800VA/420W
Referenced Min. Applicable Load		5VDC, 10mA	5VDC, 10mA	10VDC, 10mA
Contact Material		Ag Alloy	Ag Alloy	Ag Alloy

## PERFORMANCE (at initial value)

Item	Type	TRU
Contact Resistance		100m $\Omega$ Max.
Operation Time		15msec Max.
Release Time		5msec Max.
Dielectric Strength		
Between coil & contact		1500VAC 50/60HZ (1 minute)
Between contacts		750VAC 50/60HZ (1 minute)
Surge Resistiveness		3000V (between coil & contact 1 $\times$ 40 usec)
Insulation Resistance		100 M $\Omega$ Min. (500VDC)
Max. ON/OFF Switching		
Mechanically		300 operation/min
Electrically		30 operation/min
Operating Ambient Temperature		-30°C to +80°C (No water condensation and no water drop)
Operating Humidity		45 to 85% RH
Coil Temperature Rise		35 deg. Max.
Vibration		
Endurance		10 to 55HZ Double Amplitude 1.5mm
Error Operation		10 to 55HZ Double Amplitude 1.5mm
Shock		
Endurance		100G Min.
Error Operation		10G Min.
Life Expectancy		
Mechanically		10 $\times$ 10 <sup>6</sup> operations. Min. (no load)
Electrically		10 $\times$ 10 <sup>4</sup> operations. Min. (at rated coil voltage)
Weight		abt. 12grs.
UL File No.		E156521 (TV-5)
CSA File No.		LR102317
TUV File No.		R9452085

## REFERENCE DATA

Coil Temperature Rise

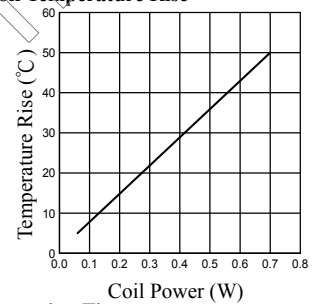

Operation Time

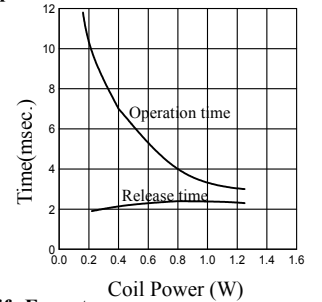

Life Expectancy

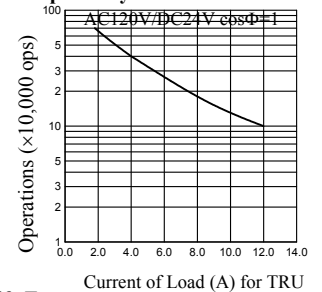

Life Expectancy

