



Innovative and Powerful Features!

- ◆ True industrial Grade Design
- ◆ Rugged Metal Case for harsh industrial Environments
- ◆ For worldwide Use – Autoselect Input and International Safety Approvals
- ◆ ATEX Certification (opt. EX)
- ◆ Model TSP 090-124N meets NEC Class 2
- ◆ Industrial Operating Temperature Range: -25°C to +70°C
- ◆ Variable Output Voltage
- ◆ Indefinite Short Circuit, Overvoltage and Overtemperature Protection
- ◆ Power Good Signal
- ◆ Remote On/Off
- ◆ Shock and Vibration Proof
- ◆ Wall Mounting (Opt.)
- ◆ Redundancy Module
- ◆ Buffer Module for Power Backup
- ◆ Battery Controller Module
- ◆ 3 Year Product Warranty



The TRACOPOWER TSP series is a new generation of high performance DIN-rail power supplies designed to work reliable also under difficult factory floor conditions. A high power reserve guarantees reliable start-up of loads with high inrush currents. Excellent electrical specifications and high immunity against electrical disturbances makes these compact modules the best choice to power sensitive loads in industrial process control systems, machine tools or other demanding industrial application. Easy installation with detachable screw terminal block and snap-on mounting on DIN-rails.

For system applications all models offer a DC-OK signal and external shut down function. Redundant operation with true power sharing is available as an option. With another option these power supplies can be extended to a perfect DC-UPS system with automatic battery management.

The TSP series power supplies complies with the latest safety and EMC standards for industrial environments and are also available with ATEX certification for applications in hazardous locations (Class I, Division 2)

Models

*Model No.	**Output Voltage (Vnom)	***Output Current (Imax)	Output Power (Pmax)
TSP 070–112	12 VDC	6.5 A	78 W
TSP 090–124	24 VDC	3.75 A	90 W
TSP 090–124N	24 VDC	3.75 A	90 W
TSP 090–148	48 VDC	2.0 A	96 W
TSP 140–112	12 VDC	13.0 A	156 W
TSP 180–124	24 VDC	7.5 A	180 W
TSP 180–148	48 VDC	4.0 A	192 W
TSP 360–124	24 VDC	15.0 A	360 W
TSP 360–148	48 VDC	7.5 A	360 W
TSP 600–124	24 VDC	25.0 A	600 W
TSP 600–148	48 VDC	12.5 A	600 W

* For ATEX compliant model add order code -EX to model no. (24 VDC models only)

** Output voltage adjustable 12 - 14 VDC, 24 - 28 VDC and 48 - 56VDC

*** Max. current at nominal output voltage and operating temperature up to 40°C max.

Product Features

The Ultimate DIN - Rail Power Supply !

Remote On/Off

Control Output for true
N+1 Redundancy or
Battery Operation

Jumper for Parallel
Operation or Battery Charge
Mode selectable by Jumper

Detachable Screw Terminal
Block for quick disconnect
and easy Installation

Rugged, Ultracompact
Metal Case, Shock and
Vibration tested per
IEC 60068-2 Standard

Double Output Terminals
for easy wiring of
multiple loads

Industrial Safety Approval
Package to comply with:
IEC/EN 60950-1
UL/cUL 60950-1
UL 508, CSA-C22.2 No.107
EN/UL 60079-15
ATEX 94/9/EC (Opt. EX)
ANSI/ISA 12.12.01

Dual Color Status
Indicator LED

Adjustable Output Voltage

EMC Compliance to
EN 61204-3 Standard
for Industrial
Power Supplies
SEMI F47

Remote Diagnostic via
floating Relay Contact
or NPN Output

Autorange Input
for worldwide Use

Convection Cooling,
no internal Fan, Thermal
Overload Protection

Self-locking DIN-rail fixing
Latch or optional Wall
Mounting Brackets

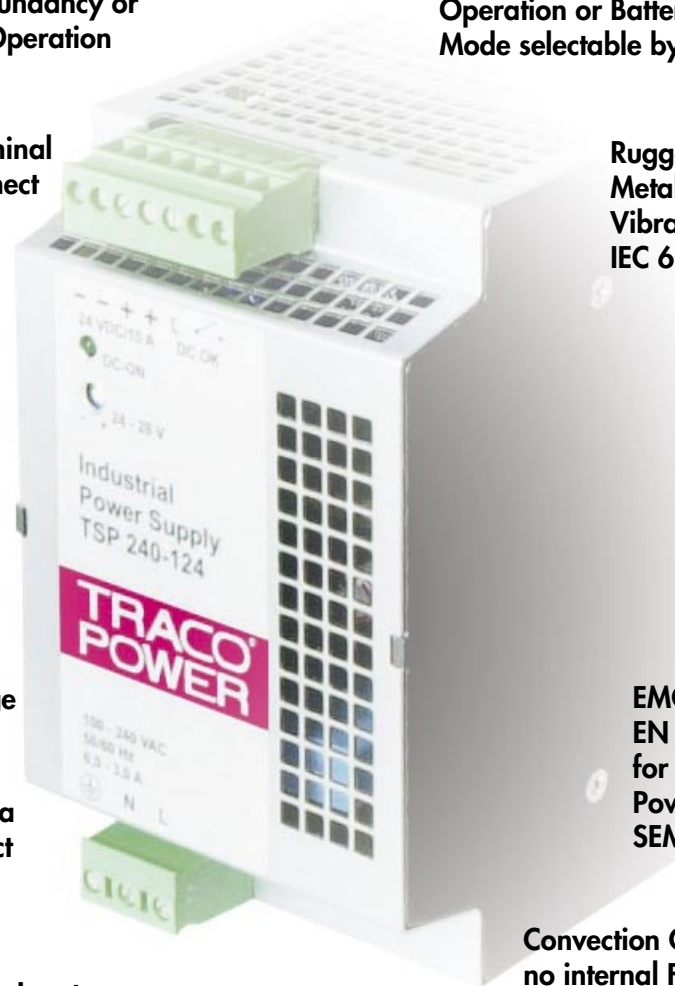

Input Specifications

Input voltage range		85–132 / 187–264 VAC autoselect
	– output current derating at operation below 100 VAC	see graph B, page 5
Input voltage frequency		47 – 63 Hz
Harmonic limits		EN 61000-3-2, Class A (for limited output power)
Holdup time		20 ms min. (full load 115/230 VAC)
Inrush current		115 VAC 230 VAC
	– TSP 070/090	< 12 A < 20 A
	– TSP 140/180	< 13 A < 25 A
	– TSP 360	< 16 A < 25 A
	– TSP 600	< 25 A < 30 A
Recommended circuit breaker, characteristic C or fuse, slow blow type	– TSP 070/090	6.0 A
	– TSP 140/180	6.0 A
	– TSP 360	10.0 A
	– TSP 600	15.0 A
Efficiency		87% typ.

Output Specifications

Output voltage adj. range	– 12 VDC models:	12 – 14 VDC
	– 24 VDC models:	24 – 28 VDC
	– 48 VDC models:	48 – 56 VDC
		At output voltage higher than nominal output voltage max. output current has to be reduced accordingly, in order not to exceed max. output power.
Regulation	– Input variation	0.5 % max.
	– Load variation (10–100 %)	0.5 % max.
Ripple and Noise (20MHz Bandwidth)		100 mV pk-pk typ. (200 mV pk-pk max. at I _{max})
Electronic short circuit protection		current limitation at I _{max} . constant current, automatic recovery
Output overvoltage protection	– 12 VDC models:	20V
	– 24 VDC models:	35V
	– 48 VDC models:	60V
Overload protection		electronic overload protection
Overtemperature protection		switch off at overtemperature, automatic restart
Power back immunity	– 12 VDC models:	16V
	– 24 VDC models:	35V
	– 48 VDC models:	63V
Status indicator		dual color LED (green: DC ok, red: DC off)
Power-Good signal	– trigger threshold:	– 12 VDC models: 9 - 11V
		– 24 VDC models: 18 - 22V
		– 48 VDC models: 36 - 46V
	– active output signal: (reference to –V _{out})	– 12 VDC models: 11.0 V ±1.0V (20 mA max. for TSP 070, 40 mA max. for TSP 140)
		– 24 VDC models: 22.0 V ±2.0V / 20mA max. (10 mA max. for TSP 090, 20mA max. for others)
		– 48 VDC models: 44.0 V ±4.0V / 15mA max.
	– relay output	DC OK = contact closed rated: 30VDC / 1.0A for 12 / 24VDC models rated: 48VDC / 0.5A for 48VDC models
Max. capacitive load		unlimited

General Specifications

Operating temperature range	– 25°C...+70°C max. (–13°F...+158°F) (for derating see graph A on page 5)	
Cooling	convection cooling, no internal fan	
Storage temperature	–25 °C...+85 °C (– 13°F...+185°F)	
Humidity (non condensing)	95 % rel. H max.	
Pollution degree	2	
Temperature coefficient	0.02 %/K	
Reliability, calculated MTBF @ 25°C acc. to IEC 61709	– TSP 070/090 – TSP 140 – TSP 180/360/600	>1.8 Mio h >1.2 Mio h >0.9 Mio h
Remote On/Off	by ext. contact. DC on: -S contact open DC off: -S connecteid via 1Kohm to -Vout	
Isolation	according to IEC/EN 60950-1, UL 60950-1, UL 508	
Safety standards	<ul style="list-style-type: none"> – Information technology equipment – Industrial control equipment – Electrical equipment of machines – Electronic equipment for power installation – Safety transformers for SMPS – Limited power source (model TSP 090-124N) – Control equipment for hazardous location 	IEC/EN 60950-1, UL 60950-1, CSA-C22.2 No. 60950-1-03 UL 508, CSA-C22.2 No. 107 EN 60204 EN 50178 EN 61558-2-4 EN 60950 sect. 2.5 and NEC Class 2 UL 60079-15 (Class I, Division 2, Groups A,B,C,D AEx n C II C T4 U) IEC/EN 60079-15 (Class I, Zone 2, EEx nC II C T4 U), (Ex) II3G EEx nAC IIC (T4)
Safety approvals and certifications	<ul style="list-style-type: none"> – CB report – UL approvals – CSA certification – (Ex) II3G ATEX 94/9/EC – GS certification 	for IEC 60950-1 www.tracopower.com/products/tsp-cb.pdf UL 60950-1 rec. File: E181381, UL 508C listed File: E210002 www.ul.com -> certifications (file no. 219759) for UL 60950-1, UL 508, UL 60079-15-02, ANSI/ISA 12.12.01, CSA-22.2 No. 60950-1-03, CSA C22.2 No. 107, CSA 60079-15-02 www.tracopower.com/products/tsp-csa.pdf certificate no. SEV 05 ATEX 0146 U (option -EX only) www.tracopower.com/products/tsp-atex.pdf for EN 60950-1, EN 60204, EN 61558-2-4 www.tracopower.com/products/tsp-gs.pdf
Class of protection	safety class I (IEC 536)	
Degree of protection	IP 20 (IEC/EN 60529)	
Electromagnetic compatibility (EMC), Emissions	<ul style="list-style-type: none"> – Conducted RI suppression on input – Radiated RI suppression 	EN 61000-6-3, EN 61204-3 EN 55011 class B, EN 55022 class B, EN 55011 class B, EN 55022 class B,
Electromagnetic compatibility (EMC), Immunity	<ul style="list-style-type: none"> – Electrostatic discharge (ESD) – Radiated RF field immunity – Electrical fast transient / burst immunity – Surge immunity – Immunity to conducted RF disturbances – Power frequency field immunity – Mains voltage dips and interruptions – Voltage sag immunity 	EN 61000-6-2, EN 61204-3 IEC / EN 61000-4-2 4 kV / 8 kV criteria B IEC / EN 61000-4-3 10 V / m criteria B IEC / EN 61000-4-4 2 kV criteria B IEC / EN 61000-4-5 1 kV / 2 kV criteria B IEC / EN 61000-4-6 10 V criteria B IEC / EN 61000-4-8 30 A / m criteria B IEC / EN 61000-4-11 criteria B/C SEMI F47 www.tracopower.com/products/TSP_SemiF47.pdf

All specifications valid at nominal input voltage, full load and +25°C after warm-up time unless otherwise stated.

General Specifications

Environment	– Vibration acc. IEC 60068-2-6; – Shock acc. IEC 60068-2-27	3 axis, sine sweep, 10-55Hz, 1g, 1oct/min 3 axis, 15g half sine, 11ms
Enclosure material		aluminium (chassis) / stainless steel (cover)
Mounting	– DIN-rail mounting – Wall mounting (option)	for DIN-rails as per EN 50022-35x15/7.5 (snap-on with self-locking spring) with wall mounting bracket - see page 12
Connection		detachable screw terminals (plugs included) 2 terminals per output
Installation instructions		www.tracopower.com/products/tsp_inst.pdf

Output Power Derating

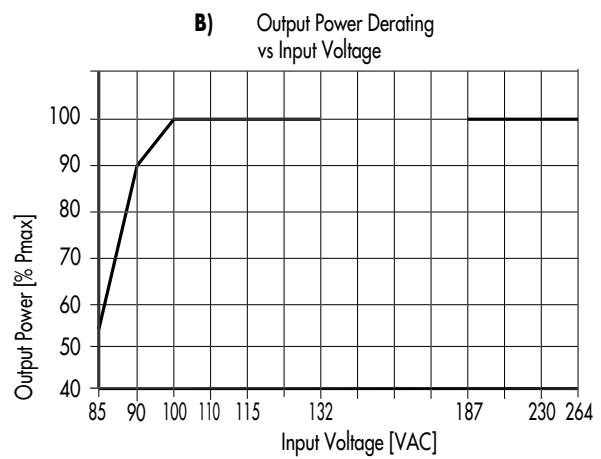
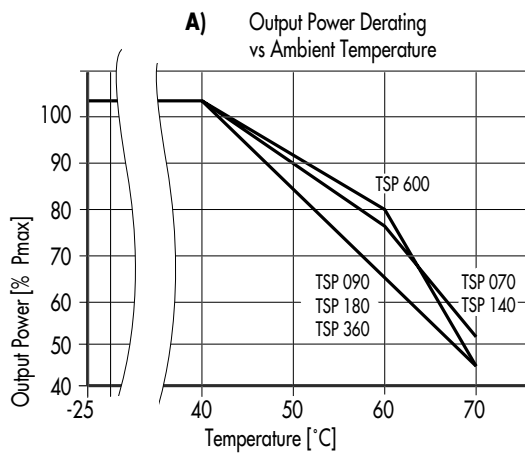

All specifications valid at nominal input voltage, full load and +25°C after warm-up time unless otherwise stated.

TSP-REM360 Redundancy Module

With this module and two power supplies of the TSP series (90, 180 and 360 W models) a highly reliable, true redundant power system can be configured without any additional components. This module enforces the equivalent sharing of the output current by each power supply. The system is fully redundant and provides the output power even if one power supply has completely failed e.g. by short circuit on the output. In the event of either, one power supply failing or being disconnected, the second unit will automatically supply the full current to the load. The redundancy of the system is monitored and if lost, indicated by an alarm output. The inputs are hot swappable and can be loaded up to 15A each.



Models

Order code (includes terminal plugs)	Input	Max Power per Input	Output Voltage adjust	Output Power max.
TSP-REM360	2 x 24 VDC 2 x Control input	2 x 360 W	24 VDC (24 - 27 VDC)	360 W

Function Diagram

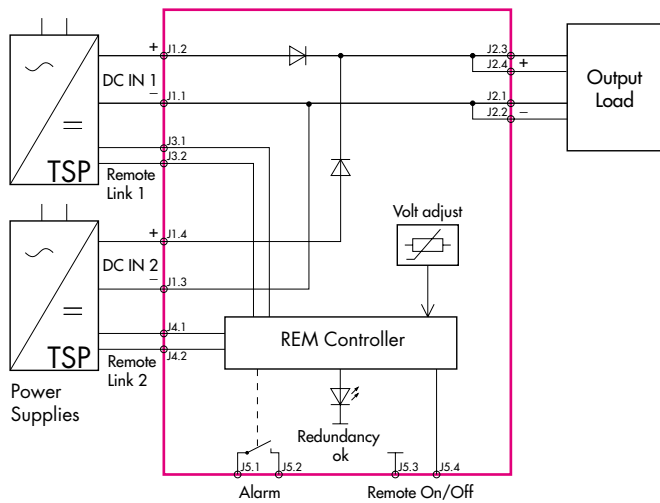

Connector Positions

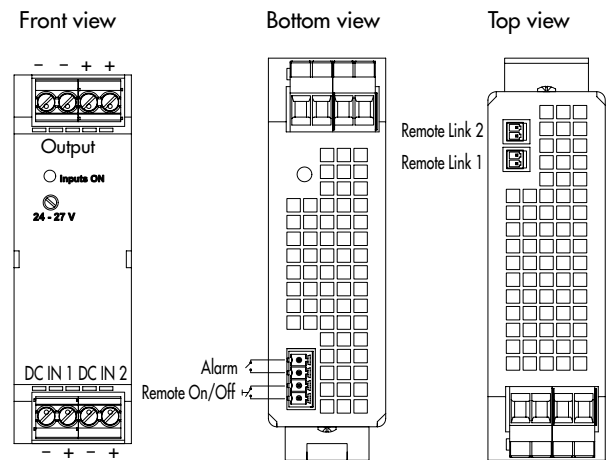

Specifications

Operating temperature	- 25°C...+70°C max. (-13°F...+158°F) derating above 40°C (104°F): 1.5%/K
Electromagnetic compatibility	in correspondence to connected units (no internal switching device)
Redundancy OK signal (Alarm)	trigger threshold at 18...22VDC, contact open if both inputs failed
Dimensions	same as model TSP 090 (see page 10)
Remote link cable (0.5m)	2 cables included with TSP-REM360 module
Remote On/Off	by ext. contact: contact open = On, contact closed = Off
Installation instructions	www.tracopower.com/products/tsp-rem_inst.pdf

TSP-BFM24 Buffer Module

The TSP-BFM24 Buffer Module will hold the output voltage of a 24VDC power supply after brown outs or voltage dips of up to ten full 50Hz cycles. During this buffer period no deterioration of the 24VDC output voltage will occur. For many applications this buffer module is an ideal and cost effective alternative to a battery based backup system. The buffer module consists of a large bank of capacitors. When the power supply is switched on, the buffer capacitors will be charged. This will take approximately 30 second and an opto-coupler signal is indicating the „READY“ condition. When a power fail occurs, the capacitor bank is discharged, maintaining the output of the buffer module at its nominal voltage. This condition is indicated by an „POWER FAIL“ signal. The hold up time is typically 200ms at 25A and 4 seconds typically at 1,2A. After 4 seconds the buffer device will switch off the output voltage. The operation modes of the module are indicated by a LED on the front panel also. The big advantage of this buffer solution is, that it is fully maintenance free and its storage capability does not deteriorate over the live time of the product.



Models

Order code (includes terminal plugs)	Operating Voltage Range	Buffer Time	Output Power max.
TSP-BFM24	24...28VDC	200ms typ. @ 25A max. 4.0 s max. @ 1.2A	600 W

Function Diagram

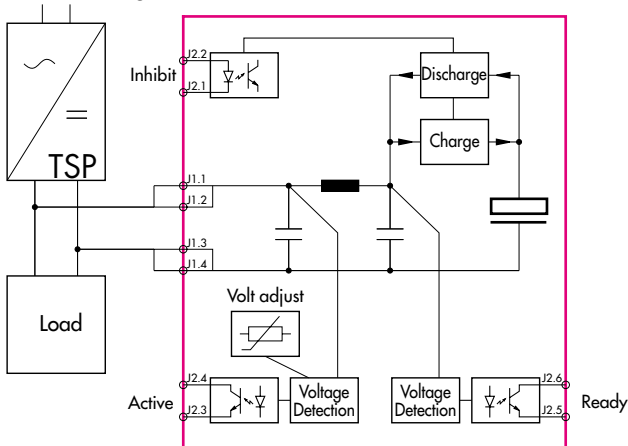

Connector Positions

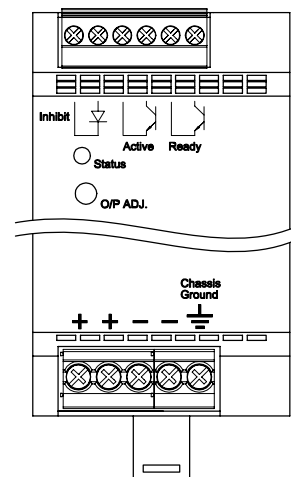

Specifications

Operating temperature	- 25°C...+70°C max. (-13°F...+158°F) derating above 40°C (104°F): 1.5%/K
Electromagnetic compatibility	in correspondence to connected units (no internal switching device)
Buffer voltage	adjustable, >1V below input voltage, min. 22VDC
Charging	0.6A max. / 30s max.
Status signals	Buffer Active , Buffer Ready (optocoupler output) and dual colour LED for status indication
Inhibit	optocoupler input: 35V max. <5mA
Dimensions	same as model TSP 140 (see page 10)
Installation instructions	www.tracopower.com/products/tsp-bfm_inst.pdf

TSP-BCM24 Battery Controller Module

This module provides a professional battery management system to charge and monitor an external lead-acid battery. Together with a power supply of the TSP series a perfect DC-UPS system can be configured. The connected battery will be charged and held in charged mode by the power supply. In case of a mains power failure the battery will supply the output power until the battery is discharged. As a consequence, the output voltage of the system is equivalent to the battery voltage. To avoid overcharging the battery, an external temperature sensor adjusts the battery voltage automatically to the required end of charge voltage. By this, the battery life time can be extended.

The battery is protected against deep discharge. Mains power and the battery status are checked and monitored continuously and failures are indicated by corresponding LED's and alarm outputs. The module provides also an external On/Off input to switch-off both, power supply and battery.



Models

Order code (includes terminal plugs)	Inputs	Input Power max	Output Voltage nom.	*Output Power max.
TSP-BCM24	24 VDC Power Supply and 24 VDC Battery	360 W	24 VDC	360 W

*reduce max. output current by battery charging current

Function Diagram

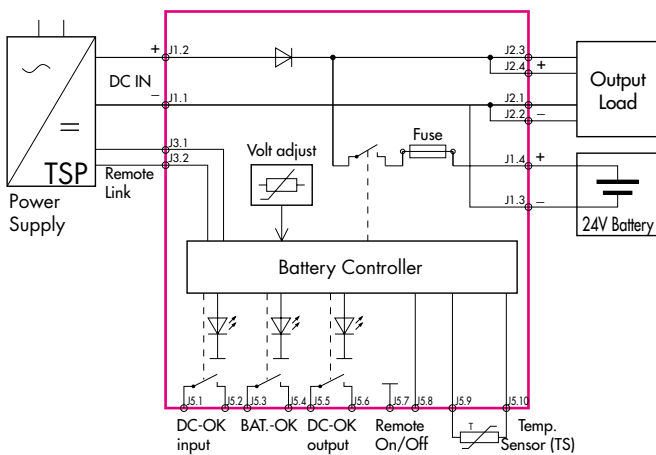

Connector Positions

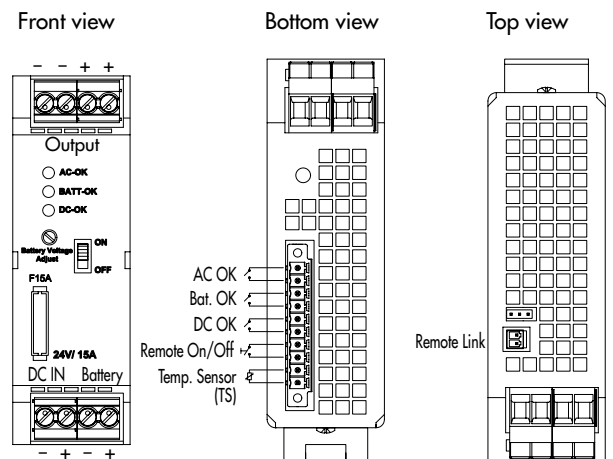

Specifications

Operating temperature	- 25°C...+70°C max. (-13°F...+158°F) derating above 40°C (104°F): 1.5%/K
Electromagnetic compatibility	in correspondence to connected units (no internal switching device)
Battery protection	over voltage, deep discharge, overcharge, short circuit- and revers connection (built-in fuse)
Status signals	DC-OK input, DC-OK output, BAT OK all relay contact closed at status OK
Rating per relay contact	30 VDC / 1.0 A max.
Dimensions	same as model TSP 090 (see page 10)
Remote link cable (0.5m)	1 cable included with TSP-BCM24 module
Remote On/Off	by ext. contact: contact open = On, contact closed = Off
Installation instructions	www.tracopower.com/products/tsp-bcm_inst.pdf

TSP-BAT Battery Pack

The TSP battery packs are designed to build, in connection with the TSP-BCM battery controller module, a complete DC-UPS system. The entire range utilizes 12V maintenance free VRLA (valve regulated lead acid) batteries made by PANASONIC. These are not spillable lead gel type batteries. Two 12V batteries are connected in series and assembled into a stainless steel enclosure, with integrated connector and connection cable.



Models

Order code (includes mating connectors)	Nominal Voltage	Charge current max.	Nominal Capacity (at 25°C, 77°F)
TSP-BAT24-034	24 VDC	0.80 A	3.4 Ah
TSP-BAT24-072		1.75 A	7.2 Ah
TSP-BAT24-120		3.00 A	12.0 Ah

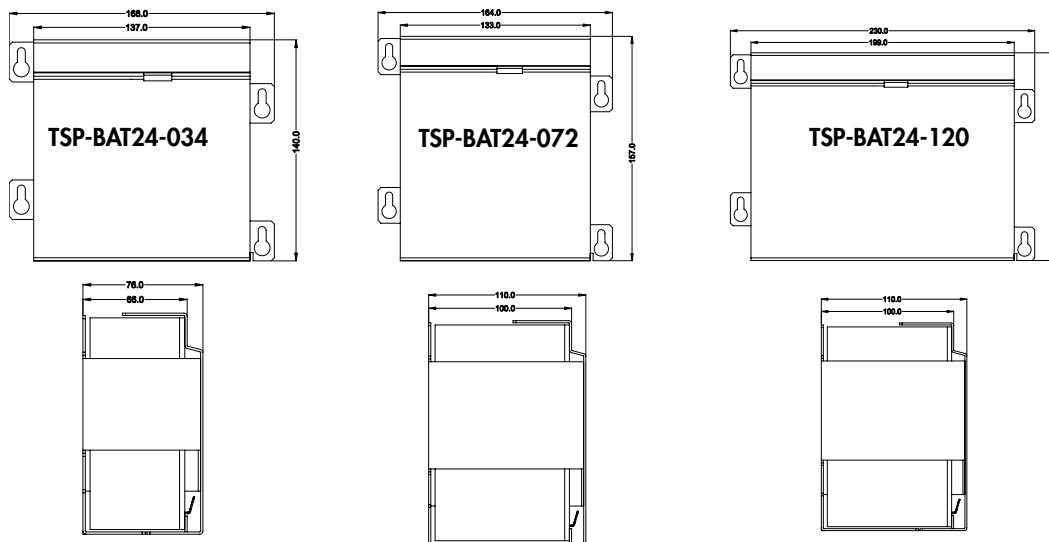

Detailed drawings in process

Specifications

Temperature ranges (max)	– during discharge – when charging / charged – storage	-15°C...+50°C max. (5°F...+122°F) 0°C...+40°C max. (32°F...+104°F) -15°C...+40°C max. (5°F...+104°F)
Battery lifetime		3-5 years see general battery information for details: www.tracopower.com/products/tsp-panas_gen.pdf
Remote link cable		1 cable (0.5m) included
Weight	TSP-BAT24-034 TSP-BAT24-072 TSP-BAT24-120	3.2kg (7.1lb) 5.8kg (12.9lb) 9.0kg (20.0lb)
Battery datasheets	TSP-BAT24-034 TSP-BAT24-072 TSP-BAT24-120	www.tracopower.com/products/tsp-panas_034.pdf www.tracopower.com/products/tsp-panas_072.pdf www.tracopower.com/products/tsp-panas_120.pdf

Outline Dimensions

TSP 070/090
(TSP-REM360)
(TSP-BCM24)

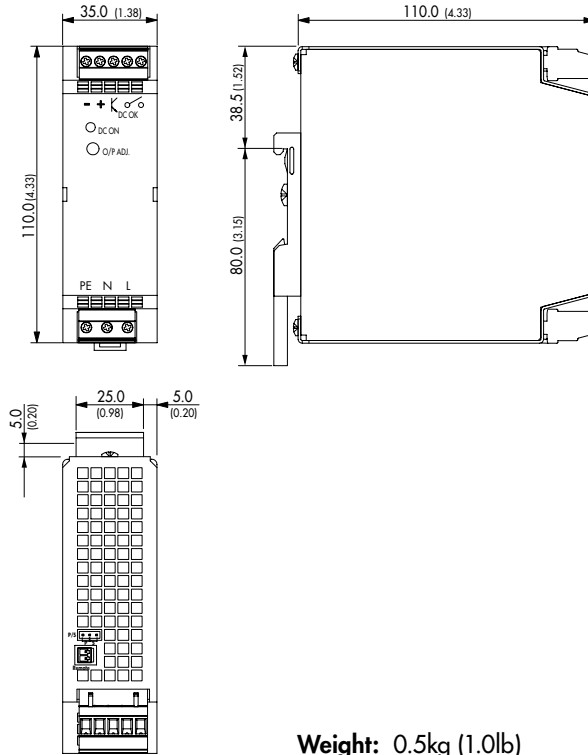

TSP 140/180
(TSP-BFM24)

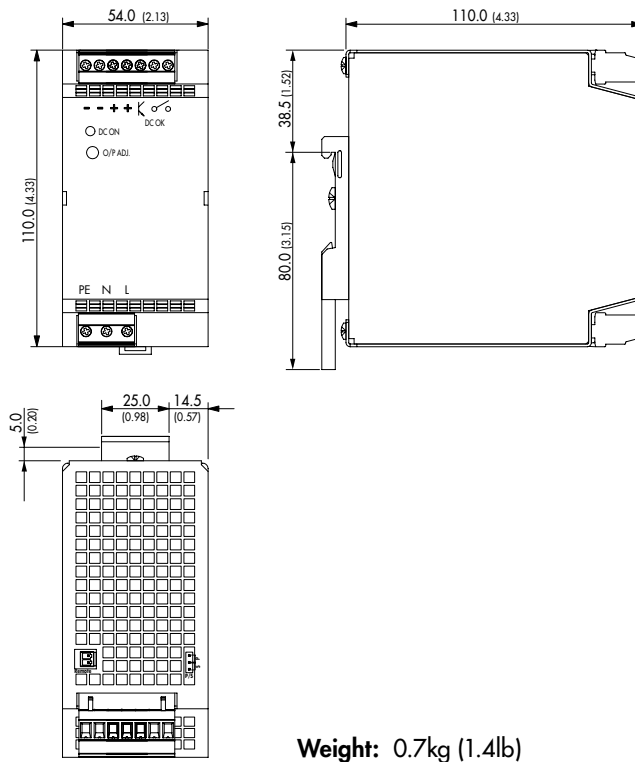

Outline Dimensions

TSP 360

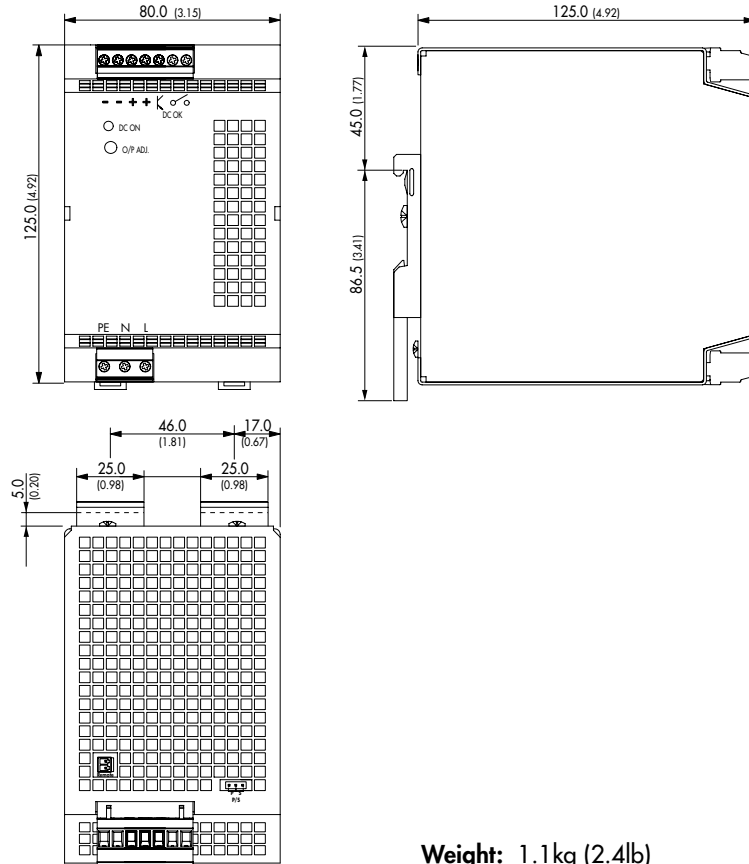

Weight: 1.1kg (2.4lb)

Dimensions in [mm], () = Inch
Tolerances: ± 0.5 mm (± 0.02)

Outline Dimensions

TSP 600

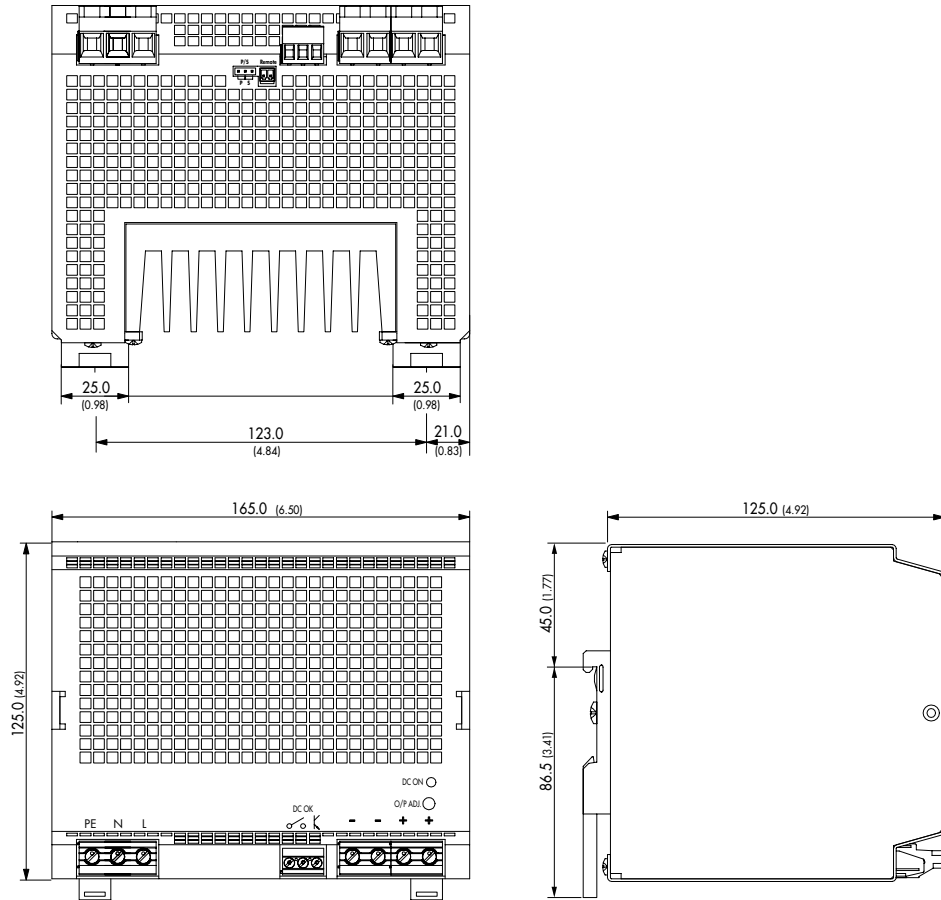

Weight: 2.8kg (6.0lb)

Dimensions in [mm], () = Inch
Tolerances: ±0.5 mm (±0.02)

TSP-WMK Wall Mounting Bracket

Ordercode of kit	For models	Content of kit
TSP-WMK01	TSP 070, TSP 090, TSP 140, TSP 180	1 bracket type A incl. M4-screw (DIN 74-Af4)
TSP-WMK02	TSP 360, TSP 600	2 brackets type B incl. M4-screws (DIN 74-Af4)

Type A:

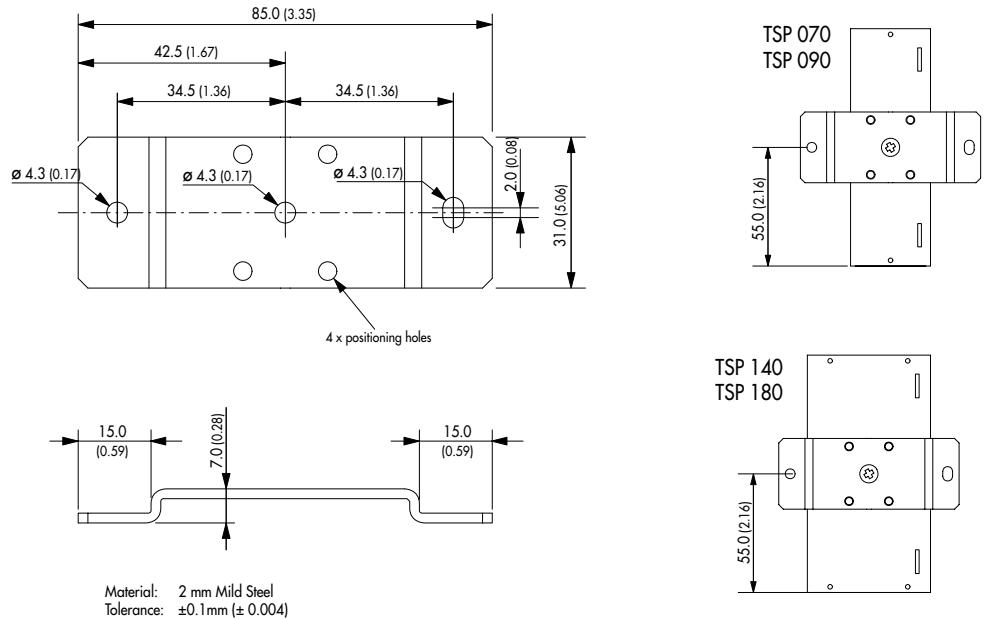

Type B:

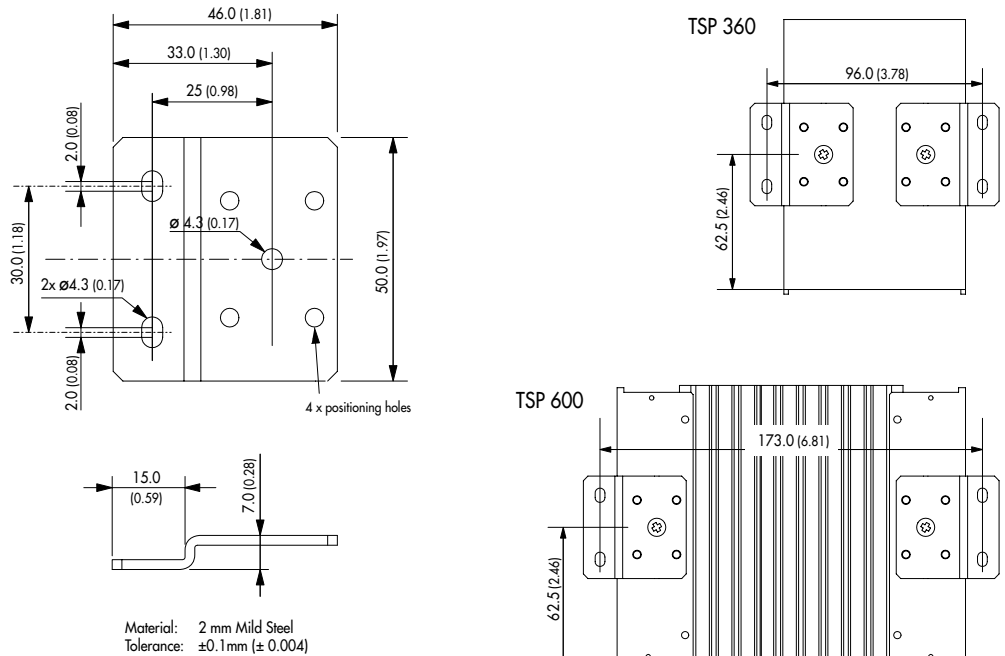

Dimensions: [mm] () = Inch

Specifications can be changed any time without notice