

Low Dropout 1 Ampere Linear Regulator Family

FEATURES

- Precision Positive Linear Voltage Regulation
- 0.5V Dropout at 1A
- Guaranteed Reverse Input/ Output Voltage Isolation with Low Leakage
- Low Quiescent Current Irrespective of Load
- Adjustable Output Voltage Version
- Fixed Versions for 3.3V and 5V Outputs
- Logic Shutdown Capability
- Short Circuit Power Limit of $3\% \cdot V_{IN} \cdot \text{Current Limit}$
- Remote Load Voltage for Accurate Load Regulation

DESCRIPTION

The UCC381-3/-5/-ADJ family of positive linear series pass regulators is tailored for low drop out applications where low quiescent power is important. Fabricated with a BiCMOS technology ideally suited for low input to output differential applications, the UCC381 will pass 1A while requiring only 0.5V of input voltage headroom. Dropout voltage decreases linearly with output current, so that dropout at 200mA is less than 100mV. Quiescent current is always less than 650 μ A. To prevent reverse current conduction, on-chip circuitry limits the minimum forward voltage to typically 50mV. Once the forward voltage limit is reached, the input-output differential voltage is maintained as the input voltage drops until undervoltage lockout disables the regulator.

UCC381-3 and UCC381-5 versions have on-chip resistor networks preset to regulate either 3.3V or 5.0V, respectively. Furthermore, remote sensing of the load voltage is possible by connecting the VOUTS pin directly at the load. The output voltage is then regulated to 1.5% at room temperature and better than 2.5% over temperature. The UCC381-ADJ version has a regulated output voltage programmed by an external user-definable resistor ratio.

(continued)

BLOCK DIAGRAM

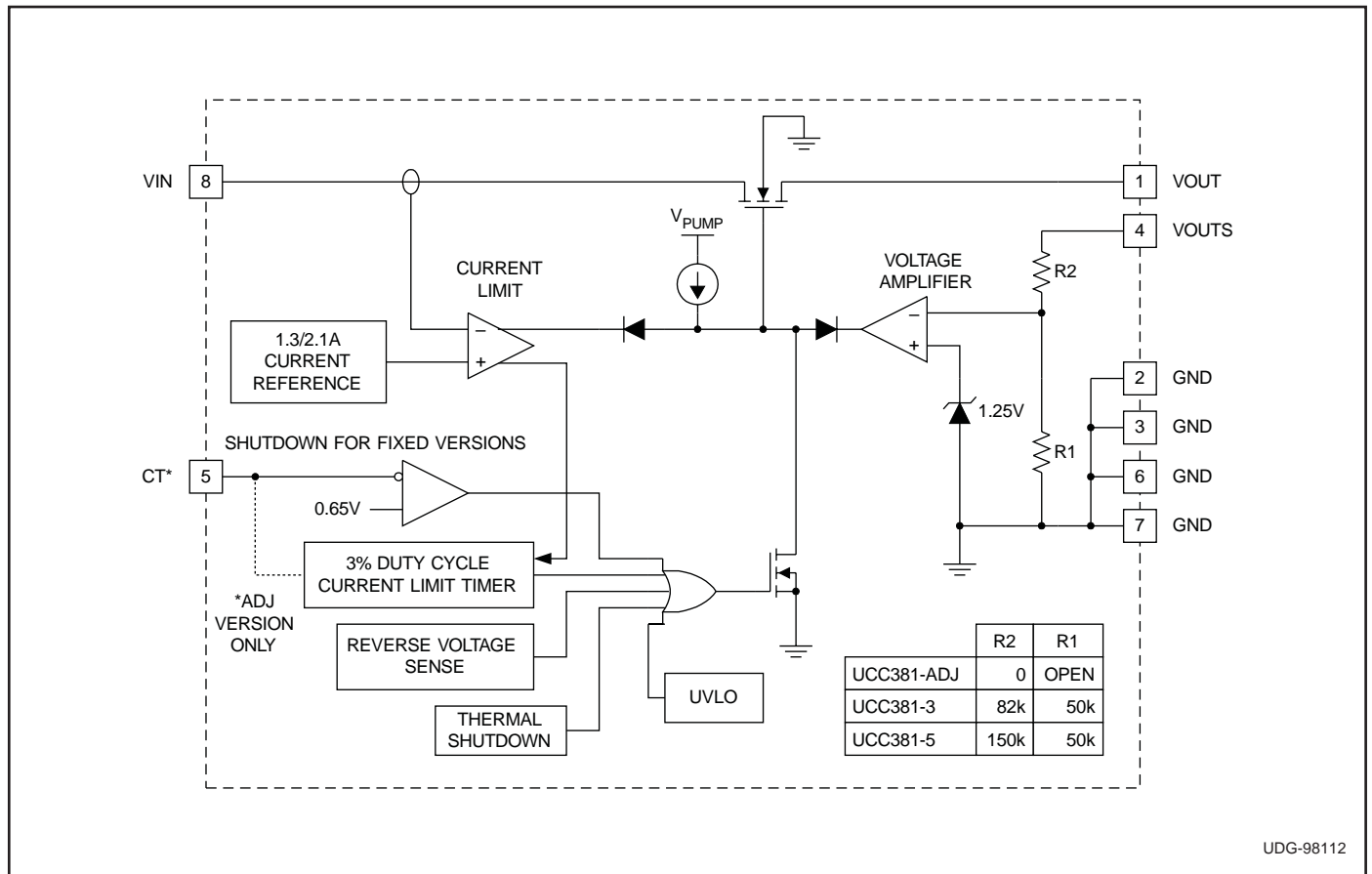

UDG-98112

ABSOLUTE MAXIMUM RATINGS

V _{IN}	9V
CT	-0.3 to 3V
Storage Temperature	-65°C to +150°C
Junction Temperature.....	-55°C to +150°C
Lead Temperature (Soldering, 10 sec.).....	+300°C

Currents are positive into, negative out of the specified terminal. Consult Packaging Section of Databook for thermal limitations and considerations of packages. All voltages are referenced to GND.

DESCRIPTION (cont.)

Short circuit current is internally limited. The device responds to a sustained overcurrent condition by turning off after a T_{ON} delay. The device then stays off for a period, T_{OFF}, that is 32 times the T_{ON} delay. The device then begins pulsing on and off at the T_{ON} / (T_{ON}+T_{OFF}) duty cycle of 3%. This drastically reduces the power dissipation during short circuit such that heat sinking, if at all required, must only accommodate normal operation. On the fixed output versions of the device T_{ON} is fixed at 400μs – a guaranteed minimum. On the adjustable version an external capacitor sets the on time. The off time is always 32 times T_{ON}.

CONNECTION DIAGRAMS

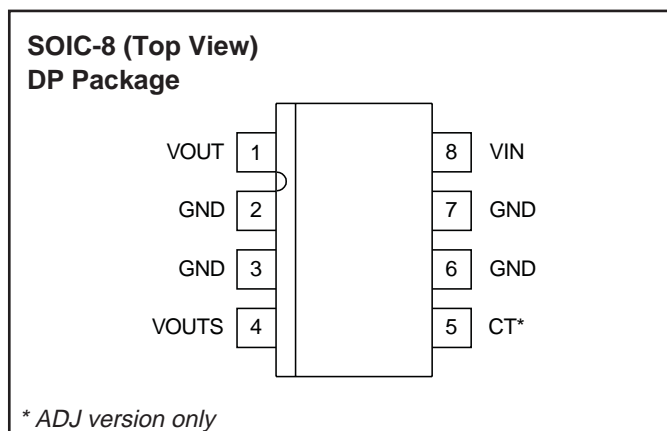

The UCC381 can be shutdown to 25μA (max) by pulling the CT pin low.

Internal power dissipation is further controlled with thermal overload protection circuitry. Thermal shutdown occurs if the junction temperature exceeds 165°C. The chip will remain off until the temperature has dropped 20°C.

The UCC281 series is specified for operation over the industrial range of -40°C to +85°C, and the UCC381 series is specified from 0°C to +70°C. These devices are available in the 8 pin DP surface mount power package. For other packaging options consult the factory.

ELECTRICAL CHARACTERISTICS: Unless otherwise stated, these specifications hold for T_A = 0°C to 70°C for the UCC381-X series and -40°C to +85°C for the UCC283-X series, V_{IN} = V_{OUT} + 1.5V, I_{OUT} = 0mA, C_{OUT} = 2.2μF, C_T = 1500pF for the UCC381-ADJ version and V_{OUT} set to 5V. T_J = T_A.

PARAMETER	TEST CONDITIONS	MIN	TYP	MAX	UNITS
UCC381-5 Fixed 5V, 1A Family					
Output Voltage	T _J = 25°C	4.925	5	5.075	V
	Over Temperature	4.875		5.125	V
Line Regulation	V _{IN} = 5.15V to 9V		1	3	mV
Load Regulation	I _{OUT} = 0mA to 1A		2	5	mV
Drop Out Voltage, V _{IN} – V _{OUT}	I _{OUT} = 1A, V _{OUT} = 4.85V, T _A < 85°C		0.5	0.6	V
	I _{OUT} = 200mA, V _{OUT} = 4.85V, T _A < 85°C		100	200	mV
Peak Current Limit	V _{OUT} = 0V		2	3.5	A
Overcurrent Threshold		1		1.8	A
Current Limit Duty Cycle	V _{OUT} = 0V		3	5	%
Overcurrent Time Out, T _{ON}	V _{OUT} = 0V	400	750	1600	μs
Quiescent Current			400	650	μA
Quiescent Current in Shutdown	V _{IN} = 9V		10	25	μA
Shutdown Threshold	At C _T Input	0.25	0.65		V
Reverse Leakage Current	1V < V _{IN} < V _{OUT} , V _{OUT} < 5.1V, at V _{OUT}			75	μA
UVLO Threshold	V _{IN} where V _{OUT} passes current	2.5	2.8	3.0	V

ELECTRICAL CHARACTERISTICS: Unless otherwise stated, these specifications hold for $T_A = 0^\circ\text{C}$ to 70°C for the UCC381-X series and -40°C to $+85^\circ\text{C}$ for the UCC283-X series, $V_{IN} = V_{OUT} + 1.5\text{V}$, $I_{OUT} = 0\text{mA}$, $C_{OUT} = 2.2\mu\text{F}$, $C_T = 1500\text{pF}$ for the UCC381-ADJ version and V_{OUT} set to 5V . $T_J = T_A$.

PARAMETER	TEST CONDITIONS	MIN	TYP	MAX	UNITS
UCC381-3 Fixed 3.3V, 1A Family					
Output Voltage	$T_J = 25^\circ\text{C}$	3.25	3.3	3.35	V
	Over Temperature	3.22		3.38	V
Line Regulation	$V_{IN} = 3.45\text{V}$ to 9V		1	3	mV
Load Regulation	$I_{OUT} = 0\text{mA}$ to 1A		2	5	mV
Dropout Voltage, $V_{IN} - V_{OUT}$	$I_{OUT} = 1\text{A}$, $V_{OUT} = 3.15\text{V}$, $T_A < 85^\circ\text{C}$		0.6	0.8	V
	$I_{OUT} = 200\text{mA}$, $V_{OUT} = 3.15\text{V}$, $T_A < 85^\circ\text{C}$		100	200	mV
Peak Current Limit	$V_{OUT} = 0\text{V}$		2	3.5	A
Overcurrent Threshold		1		1.8	A
Current Limit Duty Cycle	$V_{OUT} = 0\text{V}$		3	5	%
Overcurrent Time Out, T_{ON}	$V_{OUT} = 0\text{V}$	400	750	1600	μs
Quiescent Current			400	650	μA
Quiescent Current in Shutdown	$V_{IN} = 9\text{V}$		10	25	μA
Shutdown Threshold	At C_T Input	0.25	0.65		V
Reverse Leakage Current	$1\text{V} < V_{IN} < V_{OUT}$, $V_{OUT} < 3.35\text{V}$, at V_{OUT}			75	μA
UVLO Threshold	V_{IN} where V_{OUT} passes current	2.5	2.8	3.0	V
UCC381-ADJ Adjustable Output, 1A Family					
Regulating Voltage at ADJ Input	$T_J = 25^\circ\text{C}$	1.23	1.25	1.27	V
	Over Temperature	1.22		1.28	V
Line Regulation, at ADJ Input	$V_{IN} = V_{OUT} + 150\text{mV}$ to 9V		1	3	mV
Load Regulation, at ADJ Input	$I_{OUT} = 0\text{mA}$ to 1A		2	5	mV
Dropout Voltage, $V_{IN} - V_{OUT}$	$I_{OUT} = 1\text{A}$, $V_{OUT} = 4.85\text{V}$		0.5	0.6	V
	$I_{OUT} = 200\text{mA}$, $V_{OUT} = 4.85\text{V}$		100	200	mV
Peak Current Limit	$V_{OUT} = 0\text{V}$		2	3.5	A
Overcurrent Threshold		1		1.8	A
Current Limit Duty Cycle	$V_{OUT} = 0\text{V}$		3	5	%
Overcurrent Time Out, T_{ON}	$V_{OUT} = 0\text{V}$, $C_T = 1500\text{pF}$	400	1000	1600	μs
Quiescent Current			400	650	μA
Quiescent Current in Shutdown	$V_{IN} = 9\text{V}$		10	25	μA
Shutdown Threshold	At C_T Input	0.25	0.65		V
Reverse Leakage Current	$1\text{V} < V_{IN} < V_{OUT}$, $V_{OUT} < 9\text{V}$, at V_{OUT}			100	μA
Bias Current at ADJ Input			100	250	nA
UVLO Threshold	V_{IN} where V_{OUT} passes current	2.5	2.8	3.0	V

PIN DESCRIPTIONS

CT: For UCC381-3 and UCC381-5 versions, this is the shutdown pin which, when pulled low, turns off the regulator output and puts the device in a low current state. For the UCC381-ADJ version, a capacitor is required between the CT pin and GND to set the T_{ON} time during overcurrent according to the following (typical) equation:

$$T_{ON} = 660,000 \cdot C_{CT}$$

GND: All voltages are measured with respect to this pin. This is the low noise ground reference input for regulation. The output decoupling capacitor should be tied to PIN 7.

VIN: Positive supply input for the regulator. Bypass this pin to GND with at least $1\mu\text{F}$ of low ESR, ESL capacitance if the source is located further than 1 inch from the device.

VOUT: Output for regulator. The regulator does not require a minimum output capacitor for stability. Choose the appropriate size capacitor for the application with re-

spect to the required transient loading. For example, if the load is very dynamic, a large capacitor will smooth out the response to load steps.

VOUTS: Feedback for regulator sensing of the output voltage. For loads which are a considerable resistive distance from the VOUT pin, the VOUTS pin can be used to move the resistance into the control loop of the regulator, thereby effectively canceling the IR drop associated with the load path. For local regulation, merely connect this pin directly to the VOUT pin. For the UCC381-ADJ version, the output voltage can be set by two external resistors according to the following relationship:

$$V_{OUT} = 1.25 \cdot \left(1 + \frac{R2}{R1} \right)$$

where R1 is a resistor connected between VOUT and VOUTS and R2 is a resistor connected between VOUTS and GND.

TYPICAL APPLICATION CIRCUIT

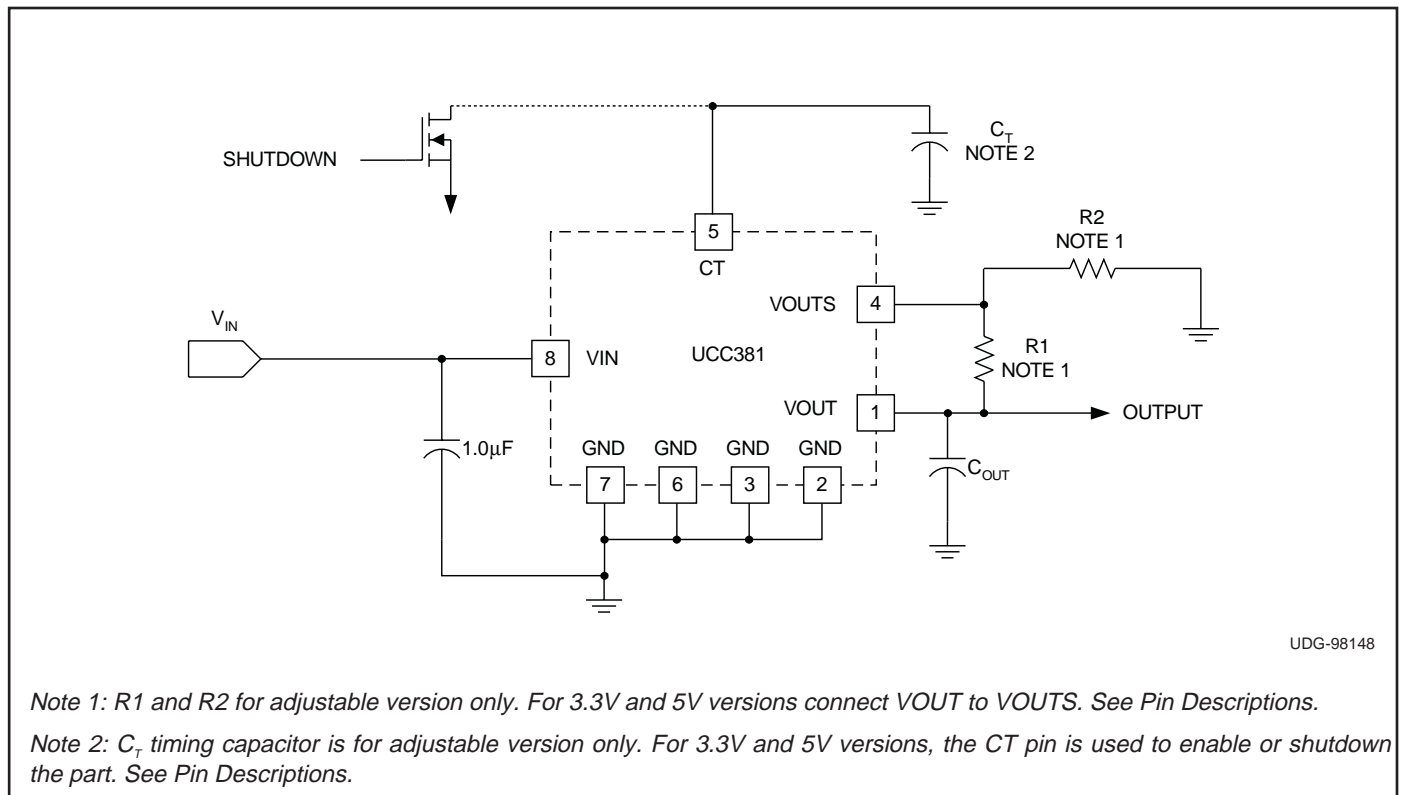

APPLICATION INFORMATION

Overview

The UCC381 family of low dropout linear (LDO) regulators provide a regulated output voltage for applications with up to 1A of load current. The regulator features a low dropout voltage and short circuit protection, making their use ideal for demanding high current applications requiring fault tolerance.

Short Circuit Protection

The UCC381 provides unique short circuit protection circuitry that reduces power dissipation during a fault. When an overload situation is detected, the device enters a pulsed mode of operation at 3% duty cycle reducing the heat sink requirements during a fault. The UCC381 has two current thresholds that determine its behavior during a fault as shown in Fig. 1.

When the regulator current exceeds the **Overcurrent Threshold** for a period longer than the T_{ON} , the UCC381 shuts off for a period (T_{OFF}) which is 32 times T_{ON} . If the short circuit current exceeds the **Peak Current Limit**, the regulator limits the current to peak current limit during the T_{ON} period. The peak current limit is nominally 1 Amp greater than the overcurrent threshold. The regulator will continue in pulsed mode until the fault is cleared as illustrated in Fig. 1.

A capacitive load on the regulator's output will appear as a short circuit during start-up. If the capacitance is too large, the output voltage will not come into regulation during the initial T_{ON} period and the UCC381 will enter pulsed mode operation. The peak current limit, T_{ON} period, and load characteristics determine the maximum value of output capacitor that can be charged. For a constant current load the maximum output capacitance is given as follows:

$$C_{OUT(max)} = (I_{CL} - I_{LOAD}) \cdot \frac{T_{ON}}{V_{OUT}} \text{ Farads} \quad (1)$$

For worst case calculations the minimum values of on time (T_{ON}) and peak current limit (I_{CL}) should be used. The adjustable version allows the T_{ON} time to be adjusted with a capacitor on the CT pin:

$$T_{ON(adj)} (\mu\text{sec}) = 660,000 \cdot C (\mu\text{Farads}) \quad (2)$$

For a resistive load (R_{LOAD}) the maximum output capacitor can be estimated from:

$$C_{OUT(max)} = \frac{T_{ON}}{R_{LOAD} \cdot \ln \left(\frac{1}{1 - \left(\frac{V_{OUT}}{I_{CL} \cdot R_{LOAD}} \right)} \right)} \text{ Farads} \quad (3)$$

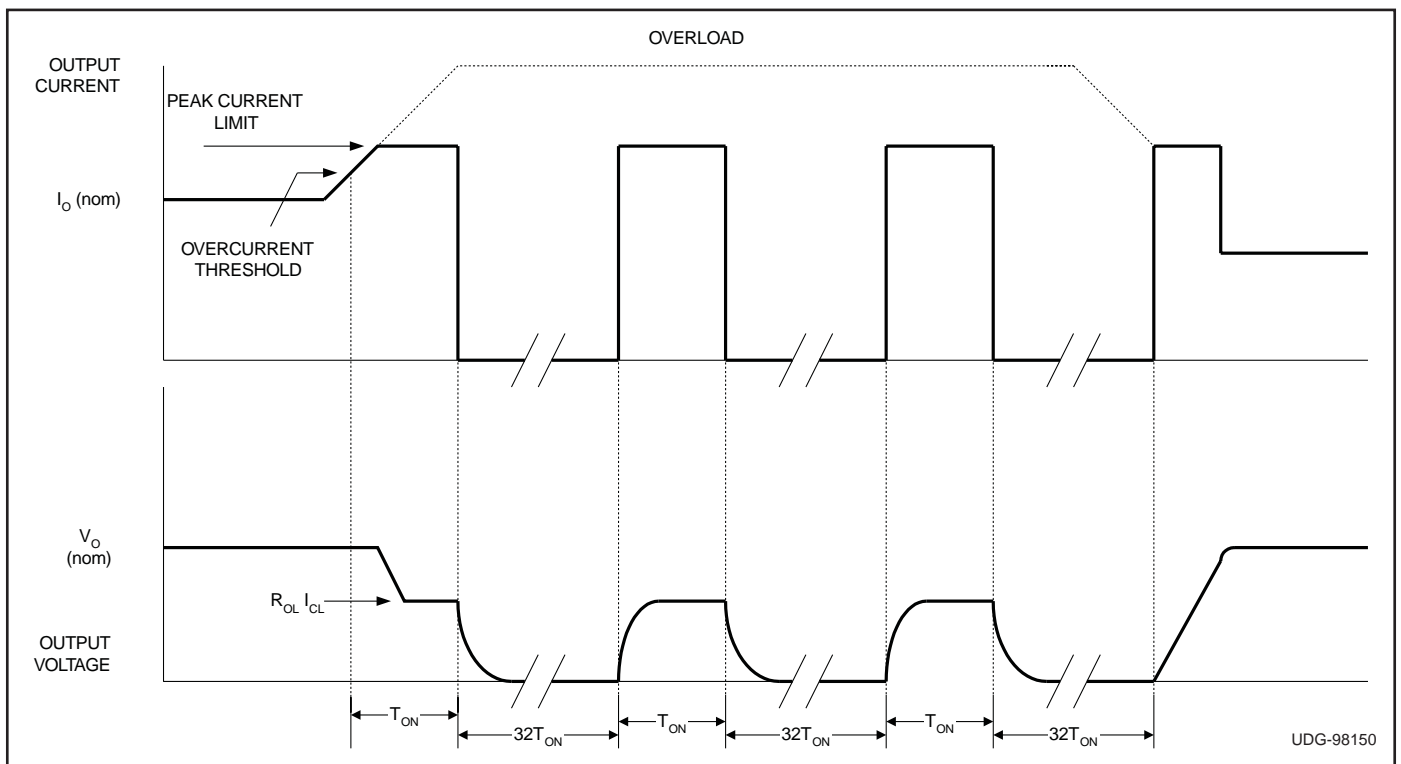

Figure 1. UCC381 short circuit timing.

APPLICATION INFORMATION (cont.)

Dropout Performance

Referring to the Block Diagram, the dropout voltage of the UCC381 is equal to the minimum voltage drop (V_{IN} to V_{OUT}) across the N-Channel MOSFET. The dropout voltage is dependent on operating conditions such as load current, input and load voltages, as well as temperature. The UCC381 achieves a low $R_{DS(ON)}$ through the use of an internal charge-pump (V_{PUMP}) that drives the MOSFET gate. Fig. 2 depicts typical dropout voltages versus load current for the 3.3V and 5V versions of the part, as well as the adjustable version programmed to 3.0V.

Fig. 3 depicts the typical dropout performance of the adjustable version with various output voltages and load currents.

Operating temperatures effect the $R_{DS(ON)}$ and dropout voltage of the UCC381. Fig. 4 graphs the typical dropout for the 3.3V and 5V versions with a 3A load over temperature.

Voltage Programming

Referring to the Typical Application Circuit, the output voltage for the adjustable version is externally programmed through a resistive divider at the V_{OUTS} pin as shown.

$$V_{OUT} = 1.25 \cdot \left(1 + \frac{R2}{R1} \right) \text{Volts} \quad (4)$$

For the fixed Voltage versions the resistive divider is internally set, and the V_{OUTS} pin should be connected to the V_{OUT} pin. The maximum programmed output voltage for the adjustable part is constrained by the 9V absolute rating of the IC (including the charge pump voltage) and its ability to enhance the N-Channel MOSFET. Unless the load current is well below the 1A rating of the device, output voltages above 7V are not recommended. The minimum output voltage can be programmed down to 1.25V, however, the input voltage must always be greater than the $UVLO$ of the part.

Shutdown Feature

All versions include a shutdown feature, limiting quiescent current to 25 μ A typical. The UCC381 is shut down by pulling the CT pin to below 0.25V. As shown in the applications circuit, a small logic level MOSFET or BJT transistor connected to the CT pin can be driven with a digital signal, putting the device in shutdown. If the CT pin is not pulled low, the IC will internally pull up on the pin, enabling the regulator. The CT pin should not be forced high, as this will interfere with the short circuit protection feature. Selection of the timing capacitor for the adjustable version is explained in the *Short Circuit Protection* section.

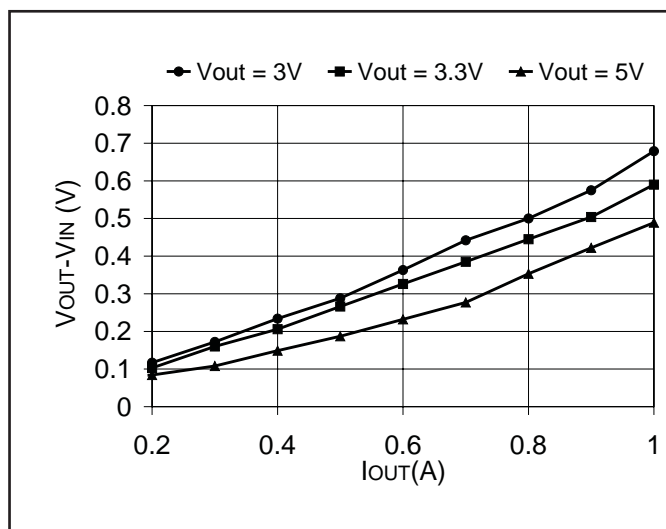

Figure 2. Typical dropout vs. load current.

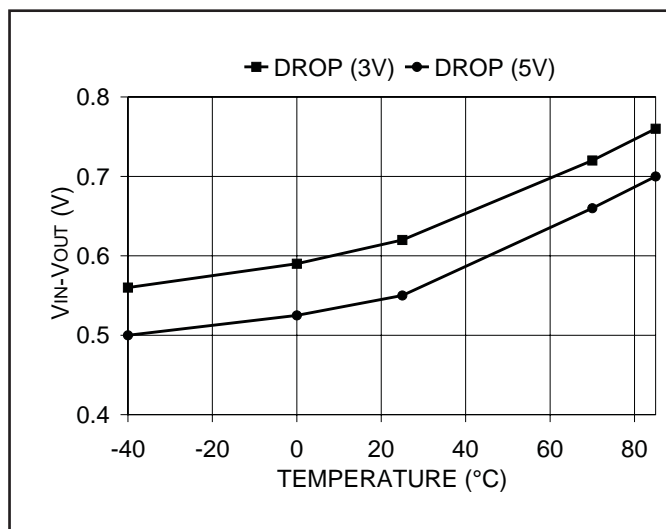

Figure 4. Typical dropout vs. temperature (1A load).

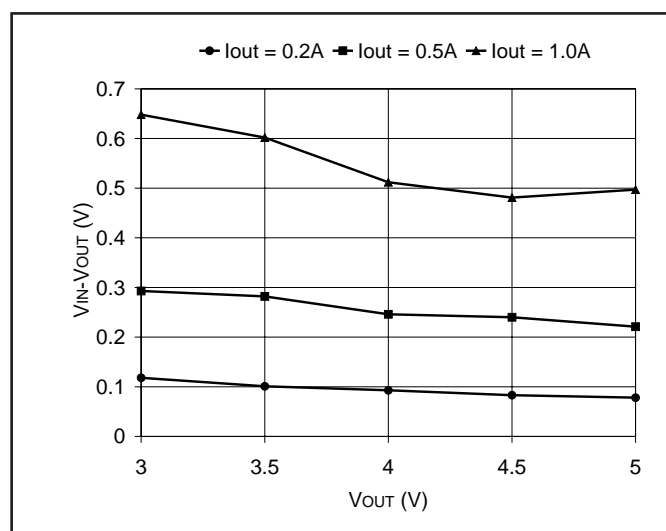

Figure 3. Typical dropout voltage vs. I_{out} and V_{out} .

APPLICATION INFORMATION (cont.)

Thermal Design

The Packing Information section of the data book contains reference material for the thermal ratings of various packages. The section also includes an excellent article *Thermal Characteristics of Surface Mount Packages*, that is the basis of the following discussion.

Thermal design for the UCC381 includes two modes of operation, normal and pulsed mode. In normal operation, the linear regulator and heat sink must dissipate power equal to the maximum forward voltage drop multiplied by the maximum load current. Assuming a constant current load, the expected heat rise at the regulator's junction can be calculated as follows:

$$T_{RISE} = P_{DISS} \cdot (\theta_{jc} + \theta_{ca}) \text{ } ^\circ\text{C} \quad (5)$$

Where theta is thermal resistance and P_{DISS} is the power dissipated. The thermal resistance of both the SOIC-8 DP package (junction to case) is 22 degrees Celsius per Watt. In order to prevent the regulator from going into thermal shutdown, the case to ambient theta must keep the junction temperature below 150C. If the LDO is mounted on a 5 square inch pad of 1 ounce copper, for example, the thermal resistance from junction to ambient becomes 40-70 degrees Celsius per Watt. If a lower ther-

mal resistance is required by the application, the device heat sinking would need to be improved.

When the UCC381 regulator is in pulsed mode, due to an overload or short circuit in the application, the maximum *average* power dissipation is calculated as follows:

$$P_{PULSE (avg)} = (V_{IN} - V_{OUT}) \cdot I_{CL} \cdot \left(\frac{T_{ON}}{33 \cdot T_{ON}} \right) \text{ Watts} \quad (6)$$

As seen in equation 6, the average power during a fault is reduced dramatically by the duty cycle, allowing the heat sink to be sized for normal operation. Although the peak power in the regulator during the T_{ON} period can be significant, the thermal mass of the package will generally keep the junction temperature from rising unless the T_{ON} period is increased to tens of milliseconds.

Ripple Rejection

Even though the UCC381 linear regulators are not optimized for fast transient applications (Refer to UC182 "Fast LDO Linear Regulator"), they do offer significant power supply rejection at lower frequencies. Fig 5. depicts ripple rejection performance in a typical application. The performance can be improved with additional filtering.

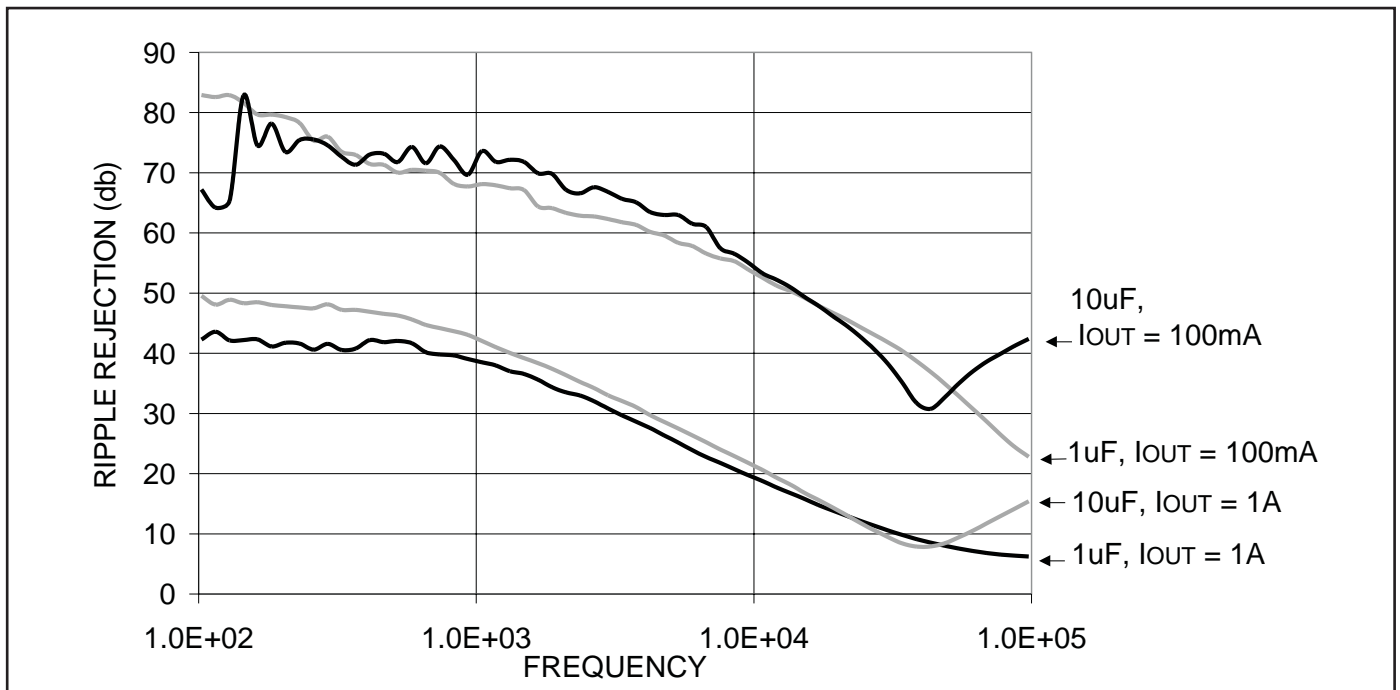

Figure 5. Ripple rejection vs. frequency.

IMPORTANT NOTICE

Texas Instruments and its subsidiaries (TI) reserve the right to make changes to their products or to discontinue any product or service without notice, and advise customers to obtain the latest version of relevant information to verify, before placing orders, that information being relied on is current and complete. All products are sold subject to the terms and conditions of sale supplied at the time of order acknowledgment, including those pertaining to warranty, patent infringement, and limitation of liability.

TI warrants performance of its semiconductor products to the specifications applicable at the time of sale in accordance with TI's standard warranty. Testing and other quality control techniques are utilized to the extent TI deems necessary to support this warranty. Specific testing of all parameters of each device is not necessarily performed, except those mandated by government requirements.

Customers are responsible for their applications using TI components.

In order to minimize risks associated with the customer's applications, adequate design and operating safeguards must be provided by the customer to minimize inherent or procedural hazards.

TI assumes no liability for applications assistance or customer product design. TI does not warrant or represent that any license, either express or implied, is granted under any patent right, copyright, mask work right, or other intellectual property right of TI covering or relating to any combination, machine, or process in which such semiconductor products or services might be or are used. TI's publication of information regarding any third party's products or services does not constitute TI's approval, warranty or endorsement thereof.

Mailing Address:

Texas Instruments
Post Office Box 655303
Dallas, Texas 75265