

6427525 N E C ELECTRONICS INC

05E 23088 D

BIPOLAR ANALOG INTEGRATED CIRCUIT

μ PC1470H

MOTOR SPEED REGULATORS

T-77-21

DESCRIPTION

The μ PC1470H is a monolithic integrated circuit intended as speed regulators for DC motors of record players, tape and cassette recorders etc. The device is packaged in a new developed 4-lead quasse-TO-126 plastic case.

FEATURES

- Excellent versatility in use.
- High Output current.
- Low Quiescent current.
- Low Reference voltage.
- Excellent parameters stability versus temperature.
- Excellent characteristic at low supply voltage.

PACKAGE DIMENSIONS (Unit: mm)

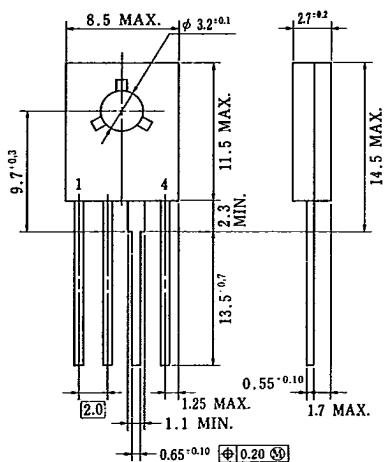

P4HP-200B

BLOCK DIAGRAM

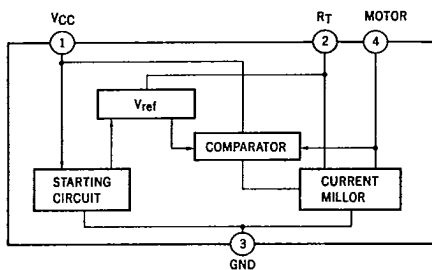

6427525 N E C ELECTRONICS INC

μ PC1470H
05E 23089 D

T-77-21

ABSOLUTE MAXIMUM RATINGS (Ta = 25 °C)

Supply Voltage	V _{CC}	18	V
Circuit Current	I ₄	2*	A
Package Dissipation	P _D	1.2	W
Operating Temperature	T _{opt}	-20 to +75	°C
Storage Temperature	T _{stg}	-40 to +150	°C
		*t ≤ 5s	

RECOMMENDED OPERATING CONDITION

Supply Voltage Range	V _{CC}	3.5 to 16	V
----------------------	-----------------	-----------	---

ELECTRICAL CHARACTERISTICS (Ta = 25 °C, V_{CC} = 12 V)

CHARACTERISTIC	SYMBOL	MIN.	TYP.	MAX.	UNIT	TEST CONDITIONS*
Reference Voltage	V _{ref}	1.10	1.27	1.40	V	I ₄ = 10 mA Fig. 1
Quiescent Current	I _d	0.5	0.8	1.2	mA	R _M = 180 Ω Fig. 4
Reflection Coefficient	k	18	20	22		R _{M1} = 44 Ω, R _{M2} = 33 Ω Fig. 2
Saturation Voltage	V _{4 (sat)}		1.5	2.0	V	V _{CC} = 4.2 V, R _M = 4.4 Ω Fig. 3
	$\frac{\Delta k}{k} / \Delta V_{CC}$	0.4			%/V	I ₄ = 100 mA, V _{CC} = 6.3 ~ 16 V Fig. 2
Line Regulation	$\frac{\Delta V_{ref}}{V_{ref}} / \Delta V_{CC}$	0.06			%/V	I ₄ = 100 mA, V _{CC} = 6.3 ~ 16 V Fig. 1
	$\frac{\Delta k}{k} / \Delta I_M$	-0.02			%/mA	I ₄ = 30 ~ 200 mA Fig. 2
Load Regulation	$\frac{\Delta V_{ref}}{V_{ref}} / \Delta I_M$	-0.02			%/mA	I ₄ = 30 ~ 200 mA Fig. 1
	$\frac{\Delta k}{k} / \Delta T_a$	0.01			%/°C	I ₄ = 100 mA, T _a = -20 ~ +75 °C Fig. 2
Temperature Coefficient	$\frac{\Delta V_{ref}}{V_{ref}} / \Delta T_a$	0.01			%/°C	I ₄ = 100 mA, T _a = -20 ~ +75 °C Fig. 1

* Pulse Test : PW ≤ 10 ms, Duty Cycle ≤ 2 %

TEST CIRCUIT

Fig. 1

$$\left(V_{ref}, \frac{\Delta V_{ref}}{V_{ref}} / \Delta V_{CC}, \frac{\Delta V_{ref}}{V_{ref}} / \Delta I_4, \frac{\Delta V_{ref}}{V_{ref}} / \Delta T_a \right)$$

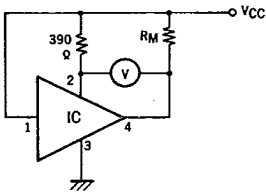
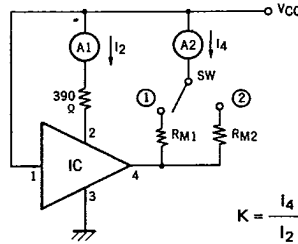

Fig. 2

$$\left(k, \frac{\Delta k}{k} / \Delta V_{CC}, \frac{\Delta k}{k} / \Delta I_4, \frac{\Delta k}{k} / \Delta T_a \right)$$



$$K = \frac{I_4 (SW \text{ ②}) - I_4 (SW \text{ ①})}{I_2 (SW \text{ ②}) - I_2 (SW \text{ ①})}$$

5

μPC1470H

6427525 N E C ELECTRONICS INC

05E 23090 D

T-77-21

Fig. 3

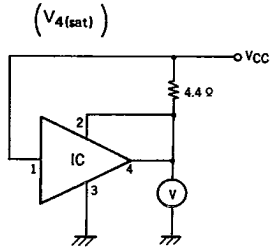
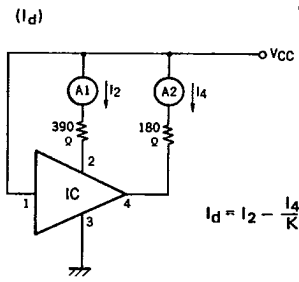
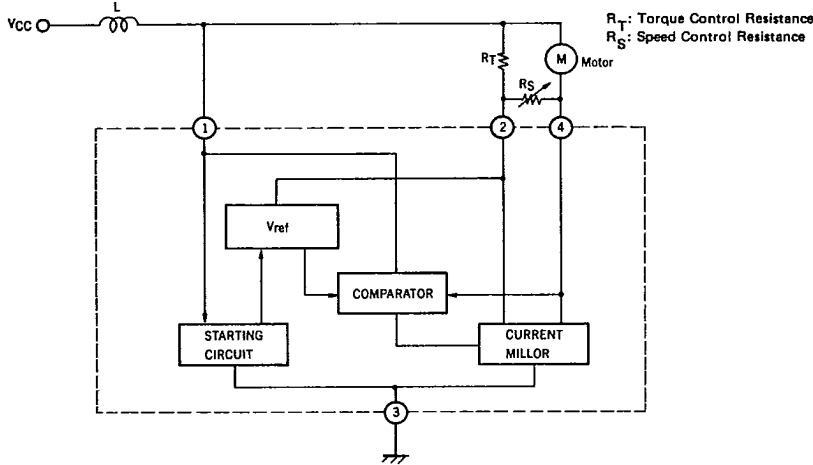

fig. 4



APPLICATION INFORMATION



[BASIC EQUATION FOR THE MOTOR]

$$\begin{cases} E_t = V_{ref} + R_T \left(i_2 + \frac{V_{ref}}{R_S} \right) \\ i_2 = \frac{1}{K} i_4 + i_q \\ i_4 = i_m + \frac{V_{ref}}{R_S} \end{cases}$$

$$\begin{aligned} E_t &= V_{ref} + R_T \left(\frac{1}{K} i_4 + i_q + \frac{V_{ref}}{R_S} \right) \\ E_t &= V_{ref} + R_T \left\{ \frac{1}{K} (i_m + \frac{V_{ref}}{R_S}) + i_q + \frac{V_{ref}}{R_S} \right\} \\ E_t &= V_{ref} \left\{ 1 + \frac{R_T}{R_S} \left(1 + \frac{1}{K} \right) \right\} + R_T i_q + \frac{R_T}{K} i_m \end{aligned}$$

They also give: $E_m = E_o + R_m i_m$

$$\begin{cases} E_o = V_{ref} \left\{ 1 + \frac{R_T}{R_S} \left(1 + \frac{1}{K} \right) \right\} + R_T i_q \\ R_m = \frac{R_T}{K} \end{cases}$$

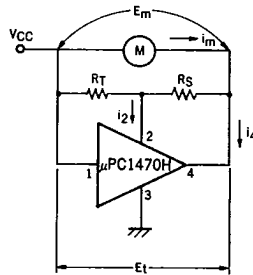

E_o : Back Electromotive Force
 R_m : Internal Resistance (of the Motor)
 K : Reflection Coefficient ($= i_4/i_2$)

