

Sound terminal expansion board based on STA350BW for STM32 Nucleo

Data brief

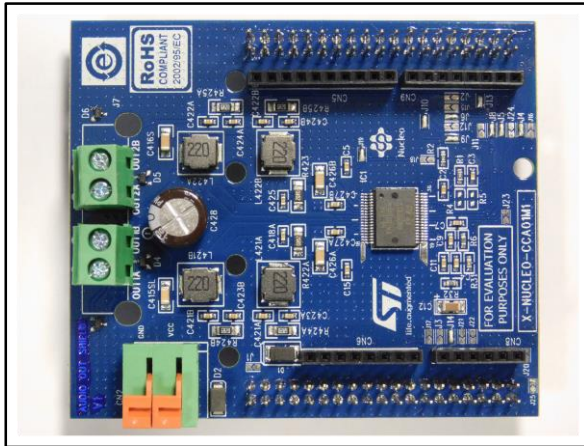

Features

- 2 channels of ternary PWM 2 x 50W @ 25V 6 Ω
- FFX™ 100 dB SNR and dynamic range
- I²C control with selectable device address
- Digital gain +48 dB -80 dB with 0.125 dB/step
- Two independent DRCs configurable as a dual-band anti-clipper (B2DRC) or independent limiters/compressors
- I²S input interface
- 3 coefficients banks for EQ preset storing with fast recall via I²C interface
- Up to 8 user-programmable biquads per channel
- Free comprehensive development firmware library and example compatible with STM32Cube firmware
- Compatible with STM32 Nucleo boards
- Equipped with ST morpho connector (upward and downward)
- Equipped with Arduino UNO R3 connector (upward) to allow multiple board connections
- RoHS compliant

Description

The X-NUCLEO-CCA01M1 is an expansion board based on the STA350BW Sound Terminal® 2.1-channel high-efficiency digital audio output system.

It can be plugged on top of an STM32 Nucleo board and is compatible with the ST morpho connector layout. It enables the output of digital audio streams to a speakers pairs connected directly to the board and allows the evaluation of the STMicroelectronics STA350BW digital audio output component. Up to two X-NUCLEO-CCA01M1 expansion boards can be plugged on top of the same STM32 Nucleo host in order to build a four-channel digital audio output system.

The communication between the STM32 MCU and the STA350BW device is performed through the I²C bus interface for setup and control purposes and the I²S bus for digital audio transmission. A dedicated connector is available on the board in order to supply the power source for the output stage.



Schematic diagram

Figure 1: Schematic diagram (1 of 3)

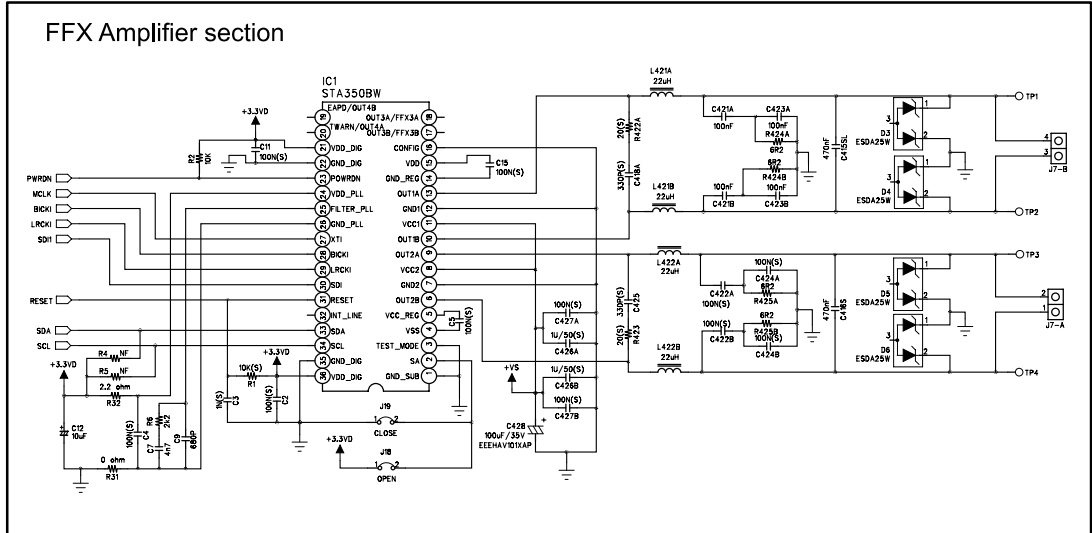

Figure 2: Schematic diagram (2 of 3)

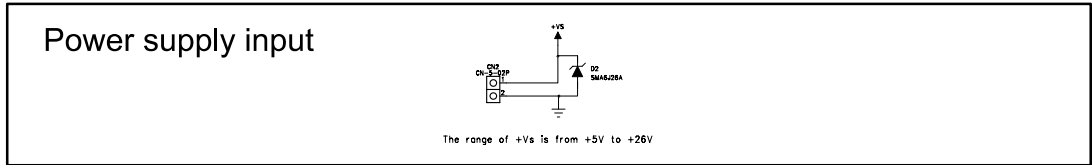
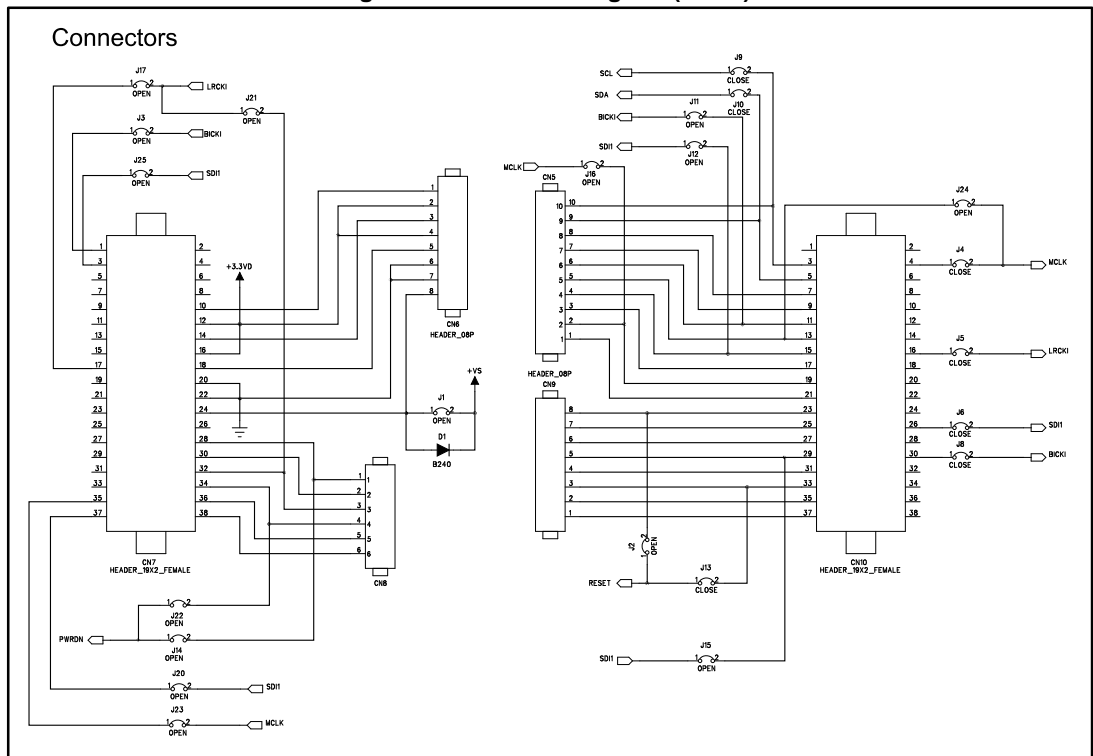

Figure 3: Schematic diagram (3 of 3)



Revision history

Table 1: Document revision history

Date	Version	Changes
17-Nov-2015	1	Initial release.
16-Dec-2015	2	Updated cover page " <i>Features</i> "

IMPORTANT NOTICE – PLEASE READ CAREFULLY

STMicroelectronics NV and its subsidiaries ("ST") reserve the right to make changes, corrections, enhancements, modifications, and improvements to ST products and/or to this document at any time without notice. Purchasers should obtain the latest relevant information on ST products before placing orders. ST products are sold pursuant to ST's terms and conditions of sale in place at the time of order acknowledgement.

Purchasers are solely responsible for the choice, selection, and use of ST products and ST assumes no liability for application assistance or the design of Purchasers' products.

No license, express or implied, to any intellectual property right is granted by ST herein.

Resale of ST products with provisions different from the information set forth herein shall void any warranty granted by ST for such product.

ST and the ST logo are trademarks of ST. All other product or service names are the property of their respective owners.

Information in this document supersedes and replaces information previously supplied in any prior versions of this document.

© 2015 STMicroelectronics – All rights reserved

Mouser Electronics

Authorized Distributor

Click to View Pricing, Inventory, Delivery & Lifecycle Information:

[STMicroelectronics:](#)

[X-NUCLEO-CCA01M1](#)