



**Shenzhen Yesok Electronics Power Co., Ltd.**  
**Branch: HONGKONG YESOK ELECTRONICS POWER CO., LIMITED.**  
 Add: A Building, Lian Tang Keng Industrial Park, Baotian 2nd Road, Xixiang, Baoan, Shenzhen Guangdong, China.  
 Tel: 86-755-61113030 Fax: 86-755-61113278 Email: sales@yyoss.cn  
 Website: www.yyoss.cn www.yesokpower.com www.yyoss.com.cn

**20W Single output waterproof led driver (Constant Voltage Type)**

**YSV-20 Series**

	<b>Features</b>
	1. 3 years warranty
	2. High efficiency 88%
	3. Economical design
	4. Protections: Short-circuit /Over-load /Over-voltage /Over-temperature
	5. Working temperature : -40℃ ~ +70℃
	6. IP67 design
7. 2~3 times burn-in tests (+50℃/-40℃ at full load with over 14 hours)	

**Application**

Led strips, electronics display screen, outdoor instruments and machines..... etc

**Specification Sheet**

Model	YSV-20 Series	YSV-20-12	YSV-20-24	YSV-20-36
<b>Output</b>	Rated Voltage (Note 1)	12VDC	24VDC	36VDC
	Output Current Range	0~1.67A	0~0.83A	0~0.55A
	Rated Power (Max)	20W	20W	20W
	Ripple and Noise (Max) (Note 2)	120mVp-p	150mVp-p	150mVp-p
	Voltage Tolerance	±3.0%	±3.0%	±3.0%
	Line Regulation	±1%	±1%	±1%
	Load Regulation	±1.0%	±1.0%	±1.0%
	Set-up, Rise Time	1500ms 80ms/230VAC, 2000ms 80ms/110VAC		
Hold-up Time	50ms/230VAC at full load, 25ms/110VAC at full load			
<b>Input</b>	Voltage Range	170~264VAC / 90~132VAC / 90~264VAC		
	Frequency Range	47~63Hz		
	Efficiency (Note 3)	83.0%	87.0%	88.0%
	AC Current	0.22A ~ 0.07A		
	Inrush Current	Cold Start at 40A/230VAC, Input at Ta: 25℃ cold start.		
	Leakage Current	< 0.5mA at 230VAC, 60Hz Input		
<b>Protection</b>	Over-Voltage	110% ~ 130% (Shut down O/P voltage, repower on to recover)		
	Over-load	130% ~ 150% (Shut down O/P voltage, repower on to recover)		
	Short Circuit	Hiccup mode, recovers automatically after faulty problem is removed		
	Over-temperature	85℃±10℃ (Shut down O/P voltage, re-power on to recover)		
<b>Environment</b>	Working Environment	-40℃ ~ +70℃		
	Working Humidity	20~90% RH non-condensing		
	Storage Environment & Humidity	-40℃ ~ +80℃		
	TEMP. Coefficient	±0.05%/℃ (0~50℃)		
	Vibration	10 ~ 500Hz, 2G 10min./1cycle, period for 60min. each along X, Y, Z axes		
<b>Safety &amp; EMC</b>	Safety Standards	EN-61347-1, EN61347-2-13, IP67, ROHS Tests, Design refer to UL8750		
	Withstand Voltage	I/P-O/P: 3KVAC, IP-FG:1.5KVAC, OP-FG: 500VAC		
	Isolation Resistance	I/P-O/P IP-FG OP-FG: 100M Ohms/500VDC / 25℃ / 70% RH		
	EMC Emission	Compliance to EN55015: 2007, EN61547:1995+A1:2000; EN61000-3-2: 2006; EN61000-3-3: 2008		
<b>Others</b>	Life Span (Note 4)	≥50000Hrs (25~30℃)		
	No Load power consumption	≤1.0W		
	MTBF (Note 5)	250K hrs min, MIL-HDBK-217F (25℃ )		
	Dimension (Note 6)	174*30*20 mm (L*W*H)		
	Packing (Note 7)	50pcs/carton		
	Weight	0.20Kg/pcs		
<b>Notes</b>	All parameter are measured at normal temperature (+25 ~ +28℃)			
	1. The rated voltage can be customized, such as 18V/27V... can be customized			
	2. Ripple & Noise are measured at 20KHz of bandwidth by using a 12" twisted pair-wire terminated with a 0.1 uf & 47uf parallel capacitor (at full load)			
	3. The efficiency measured at Max output voltage, and 230VAC with full load, if with 110VAC the efficiency will be lowered 1% ~ 2%; Working 1~2 hours, efficiency will be higher 0.5% ~ 1% than the initial stage			
	4. This measured at 120VAC, 80% ~85% load with environmental temperature about +25℃~+30℃, the outer housing temperature with +55℃ or so.			
	5. This measured at 120VAC, 80% ~85% load with environmental temperature about +25℃~+30℃, the outer housing temperature with +55℃ or so.			
	6. More details see the following mechanical draft.			
7. The 50pcs packing method is not suitable for led drivers with waterproof connector				

## Mechanical Specification

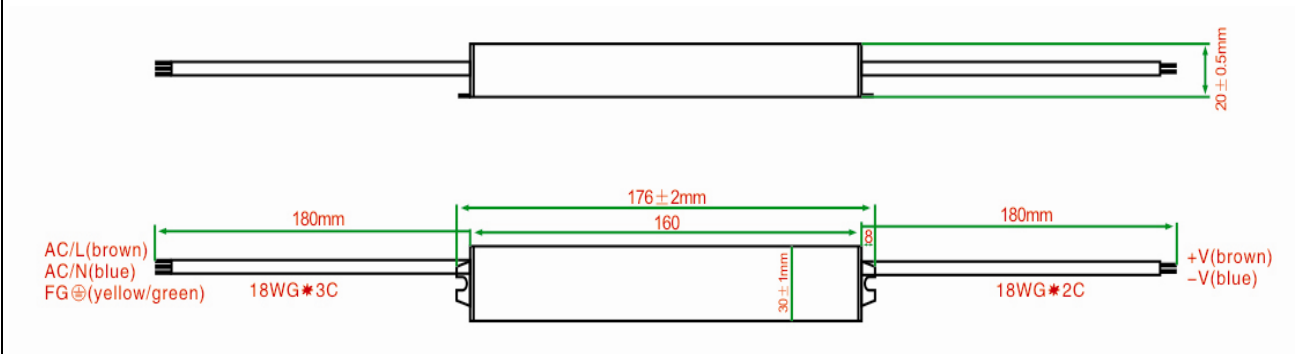

## Block Diagram

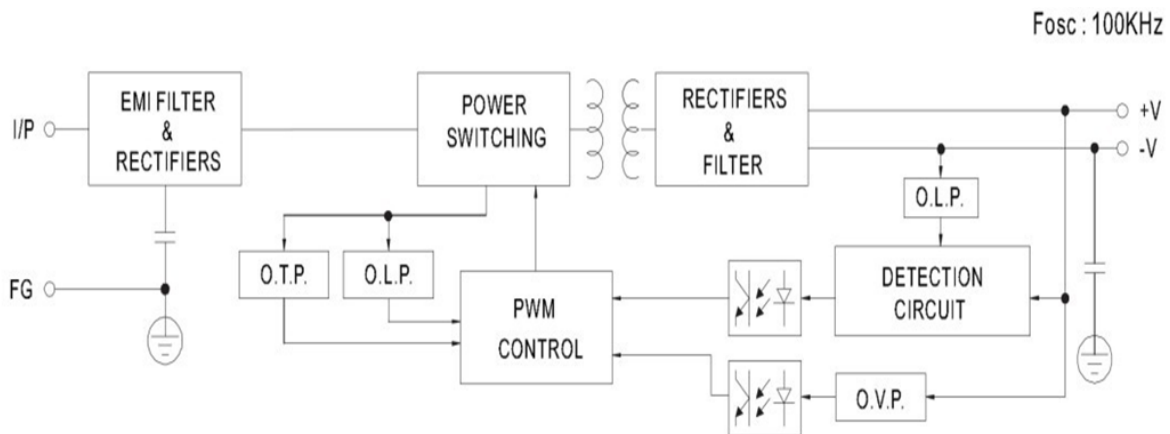

## Derating Curve

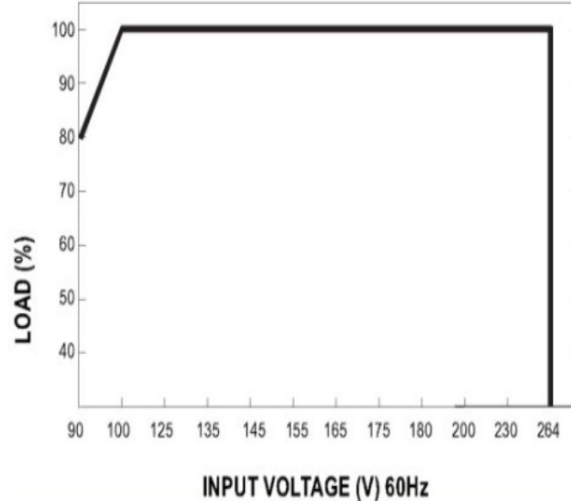
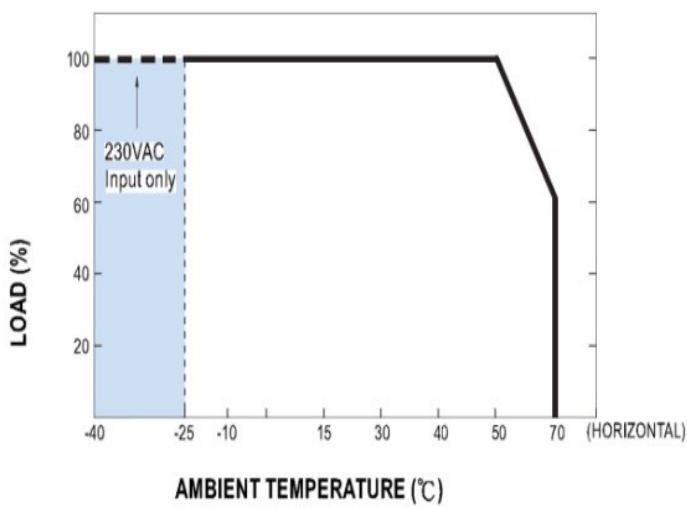

Efficiency & Load of (24V) (110VAC / 230VAC)

