

Global Connector Technology Ltd. - SIM5051 : SIM Card Connector, Hinged Type, 6 Pin, SMT, 1.85mm Profile

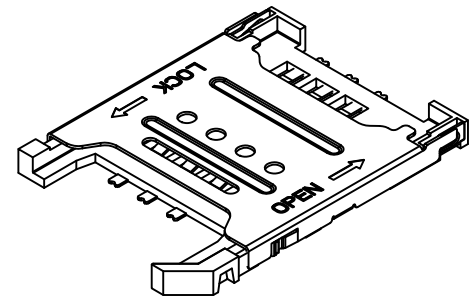
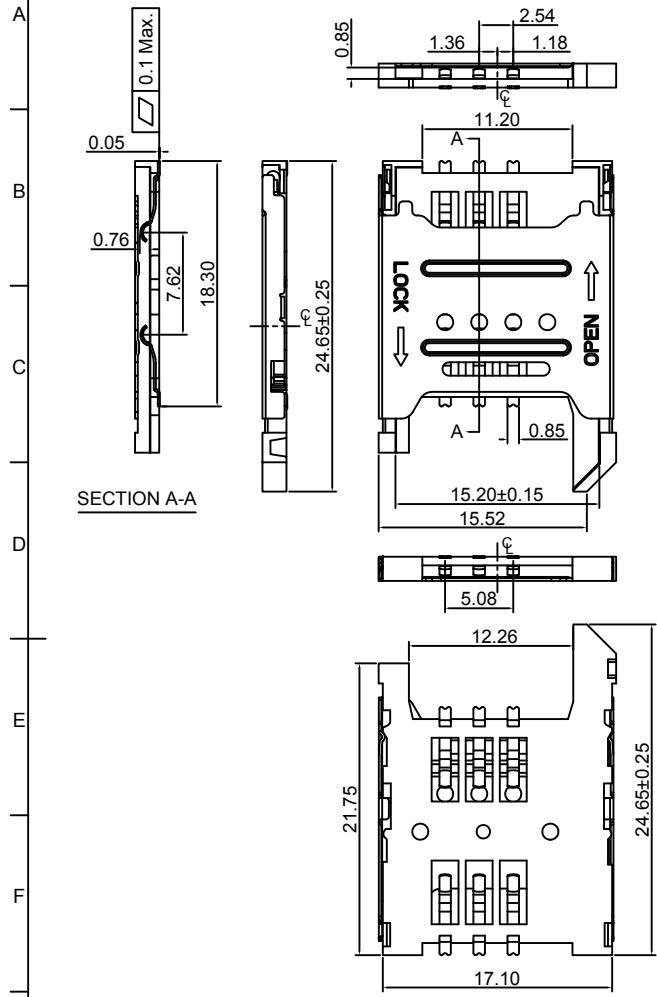

- C1---->VCC
- C2---->RST
- C3---->CLK
- C5---->GND
- C6---->Vpp
- C7---->I/O

RECOMMENDED PCB LAYOUT
GENERAL TOLERANCE ±0.05
 AS VIEWED FROM COMPONENT SIDE

- Solder Area
- Component Outline

Ordering Grid

SIM5051 - **6** - **0** - **18** - **00** - **A** REQUEST SAMPLES AND QUOTATION

No. of Contacts: 6

Card Detection Switch: 0 = Without

Packing Options: A = Tape & Reel (700 per Reel)

Locating Post: 00 = Without

Specification 规格:

Material 物料规格:
 Plastic Housing 塑胶外壳: Hi-Temp Thermoplastic UL94V-0, E106764
 Black 高温塑胶, 黑色
 Contact Terminal 接触端子: Phosphor Bronze 磷青铜
 Metallic Shell & Hinge 金属外壳及铰链: Stainless Steel - SUS304

Plating 电镀规格:
 Contact Terminal plating 接触端子部分电镀:
 Under-plating 底层电镀: 50µ" Nickel 镀镍 50µ"
 Contact Area 接触部分: 3µ" Gold 镀金 3µ"
 Soldering Area 焊接部分: Gold Flash 镀金

Electrical 电气规格:
 Voltage Rating 电压额定值: 50VAC (R.M.S.) Max.
 Current Rating 电流额定值: 1A AC/DC
 Operating Temperature 工作温度: -40°C to +85°C
 Contact Resistance 接触电阻值: 50 mΩ Typ., 100 mΩ max.
 Insulating Resistance 绝缘电阻值: 1000 MΩ Min. (Apply 施加 500VDC)
 Dielectric Withstanding Voltage 耐电压: Withstand 500 V AC for 1 minute 能承受 500 V AC 1 分钟

Mechanical 机械性规格:
 Durability 耐久性: 5,000 cycles 5,000 次插拔

| | |
|----------|------------------|
| By | AJO |
| DETAIL | PCN SIM 5051-003 |
| REV DATE | E1 24/01/14 |



| | | | |
|------------------------------|---------------|--|-----------|
| Tolerances (Except as noted) | | Part Number:- | Date:- |
| Dimensions in mm | | SIM5051 | 04 OCT 09 |
| X.X ± 0.25 | X.* ± 1* | Description:- SIM Card Connector, Hinged Type, 6 Pin, SMT, 1.85mm Profile | |
| X.XX ± 0.15 | X.X* ± 0.5* | | |
| X.XXX ± 0.050 | X.XX* ± 0.25* | | |
| Third Angle Projection | | © THIS DRAWING IS CONFIDENTIAL AND MUST NOT BE COPIED OR DISCLOSED WITHOUT WRITTEN CONSENT | |

GCT

www.gct.co

| | | | | | |
|-----------|-------------|-------------------|-------------|--------|---------------|
| Scale NTS | Revision E1 | Material See Note | Drawn by SA | E & OE | Sheet No. 1/2 |
|-----------|-------------|-------------------|-------------|--------|---------------|

Global Connector Technology Ltd. - SIM5051 : SIM Card Connector, Hinged Type, 6 Pin, SMT, 1.8mm Profile

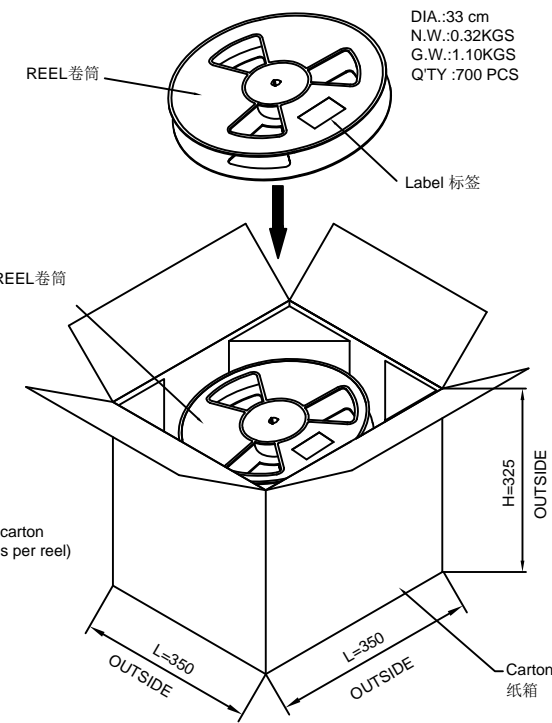
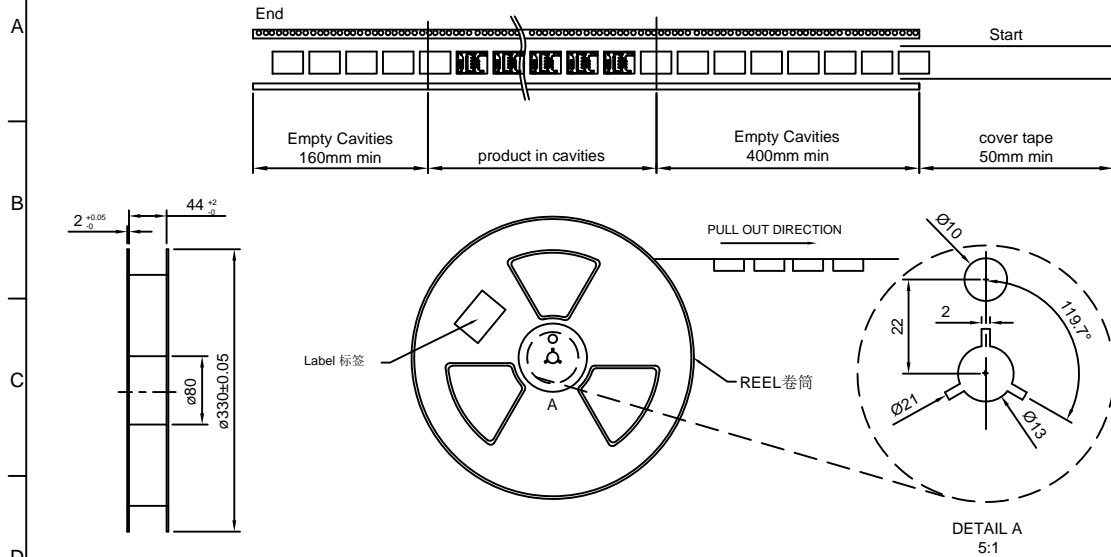

N.W: 5.04KG
G.W: 9.57KG
Q'ty: 5600Pcs per carton
(8 reels, 700 pieces per reel)

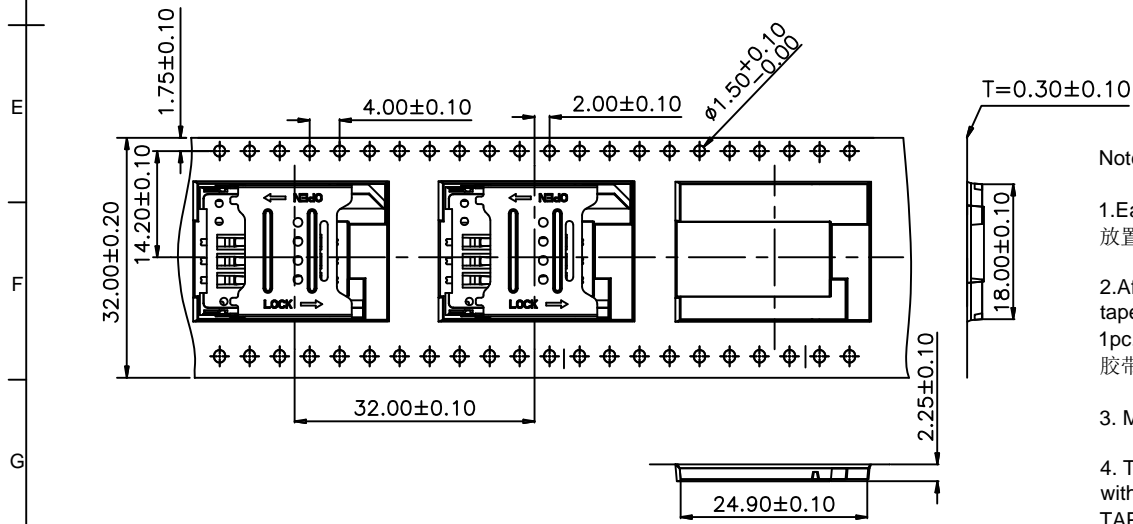

Notes注意:

1. Each cavity will hold 1pc. Placement methods are shown in the diagrams. 每穴放置1pc产品, 放置方式如图所示
2. After the packing machine filled the REEL, tangle the REEL one more loop with protection tape, stick adhesive tape on the four quadrants of the REEL, to avoid out-spreading. Stick 1pc. of label on each REEL. 包装机包好后,再缠上一圈电周波,在REEL的四个登峰造极点贴上胶带,以防止REEL张开,每REEL贴1PC标签
3. Method of Packing is Hot-Melting. 包装方式是热熔式
4. The peel-off force between the COVER TAPE & CARRY TAPE is: 0.1N-0.7N (variation within 0.3N). Peel-off angle: 165-175 degree; Speed of peel-off: 250mm-300mm/min. COVER TAPE与CARRY TAPE剥离力: 0.1N-0.7N (跳动量在0.3N以内)剥离角度: 165-175度; 剥离速度: 250mm-300mm/分钟

| | |
|--------|------------------|
| By | AJO |
| DETAIL | PCN SIM 5051-003 |
| REV | E1 |
| DATE | 24/01/14 |



| | | |
|------------------------------|--|-------------|
| Tolerances (Except as noted) | Part Number:- | Date:- |
| Dimensions in mm | SIM5051 | 04 OCT 09 |
| | Description:- | |
| | SIM Card Connector, Hinged Type, 6 Pin, SMT, 1.85mm Profile | |
| | © THIS DRAWING IS CONFIDENTIAL AND MUST NOT BE COPIED OR DISCLOSED WITHOUT WRITTEN CONSENT | |
| Third Angle Projection | Scale NTS | Revision E1 |

GCT
www.gct.co

| | | | |
|-------------------|-------------|--------|---------------|
| Material See Note | Drawn by SA | E & OE | Sheet No. 2/2 |
|-------------------|-------------|--------|---------------|