

# Pololu

## Pololu Dual VNH5019 Motor Driver Shield for Arduino Pololu item #: 2502

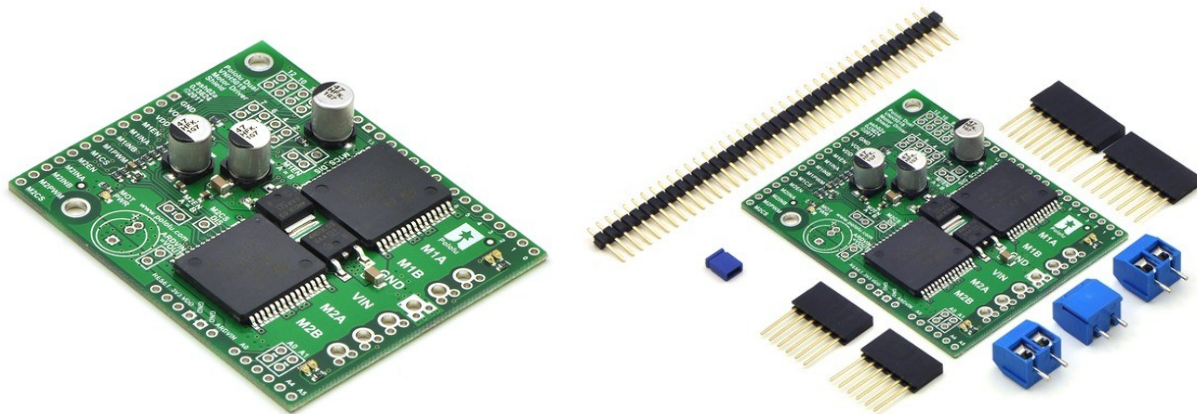

This motor driver shield and its corresponding Arduino library make it easy to control two bidirectional, high-power DC motors with an [Arduino](#) or Arduino clone. The board features a pair of robust VNH5019 motor drivers from ST, which operate from 5.5 to 24 V and can deliver a continuous 12 A (30 A peak) per channel, and incorporates most of the components of the typical application diagram on page 14 of the [VNH5019 datasheet](#) (629k pdf), including pull-up and protection resistors and FETs for reverse battery protection. It ships fully populated with its SMD components, including the two VNH5019 ICs, as shown in the picture to the right; stackable Arduino headers and terminal blocks for connecting motors and motor power are included but are not soldered in (see the Included Hardware section below).

This versatile motor driver is intended for a wide range of users, from beginners who just want a plug-and-play motor control solution for their Arduinos (and are okay with a little soldering) to experts who want to directly interface with ST's great motor driver ICs. The Arduino pin mappings can all be customized if the defaults are not convenient, and the VNH5019 control lines are broken out along the left side of the board for general-purpose use without an Arduino (see the right connection diagram below). This versatility, along with an option to power the Arduino directly from the shield, sets this board apart from similar competing motor shields.

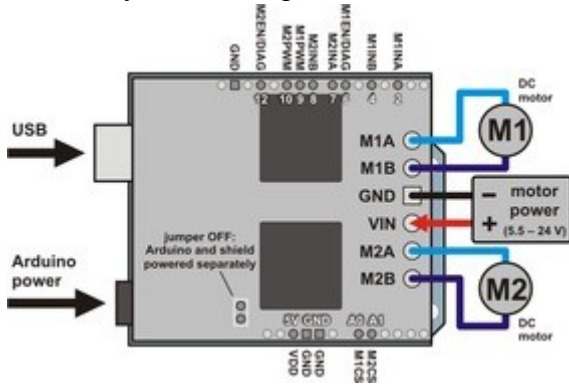



 Dual VNH5019 motor driver shield with an Arduino (shield and Arduino powered separately).

**Features**



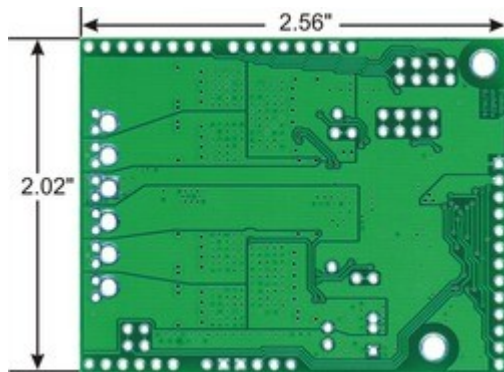

 Pololu dual VNH5019 motor driver shield, assembled and connected to an Arduino Uno.

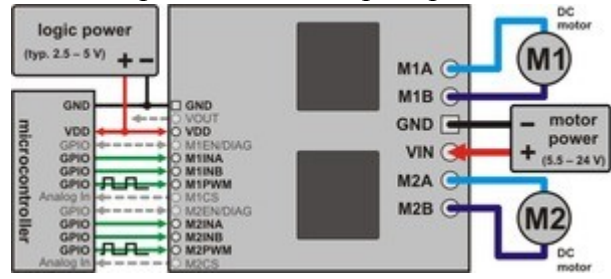

 Pololu dual VNH5019 motor driver shield for Arduino, bottom view with board dimensions.

- Wide operating voltage range: 5.5 – 24 V<sup>1</sup>
- High output current: up to 12 A continuous (30 maximum) per motor
- Motor outputs can be combined to deliver up to 24 A continuous (60 A maximum) to a single motor



 Dual VNH5019 motor driver shield connected to a microcontroller (gray connections are optional).

- Inputs compatible with both 5V and 3.3V systems (logic high threshold is 2.1 V)
- PWM operation up to 20 kHz, which is ultrasonic and allows for quieter motor operation
- Current sense voltage output proportional to motor current (approx. 140 mV/A)
- Motor indicator LEDs show what the outputs are doing even when no motor is connected
- Can be used with an Arduino or Arduino clone (through shield headers) or other microcontroller boards (through 0.1" header along the left side)
- When used as a shield, the motor power supply can optionally be used to power the Arduino base as well
- Arduino pin mappings can be customized if the default mappings are not convenient
- [Arduino library](#) makes it easy to get started using this board as a motor driver shield
- Detailed [user's guide](#)
- Reverse-voltage protection
- Robust drivers:
  - Can survive input voltages up to 41 V
  - Undervoltage and overvoltage shutdown
  - High-side and low-side thermal shutdown
  - Short-to-ground and short-to-Vcc protection

<sup>1</sup> While the overvoltage protection typically kicks in at 27 V, it can trigger at voltages as low as 24 V, so we do not recommend using this motor driver with 24 V batteries, which significantly exceed 24 V when fully charged. If the shield is configured to power an Arduino or Arduino clone, the supply voltage must conform to that Arduino's input voltage requirements.

## Included Hardware

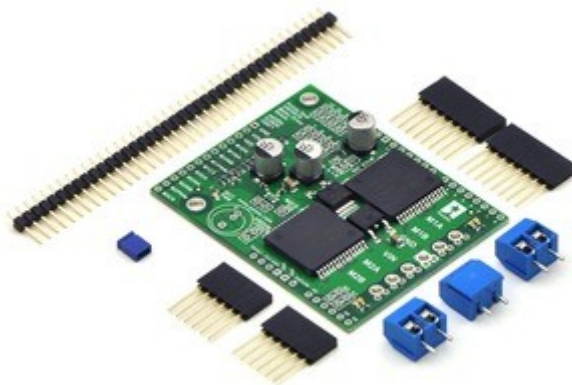

**Pololu dual VNH5019 motor driver shield for Arduino with included**

This motor driver board ships with all of the surface-mount parts populated. However, soldering is required for assembly of the included through-hole parts. The following through-hole parts are included:

- two extended 1×8 female headers (for Arduino shields)
- two extended 1×6 female headers (for Arduino shields)
- three [2-pin 5mm terminal blocks](#) (for shield power and motor outputs)
- 40-pin [0.1" straight breakaway male header](#) (may ship in several pieces, such as two 20-pin strips)

A [0.1" shorting block](#) (for optionally supplying shield power to Arduino) is also included.

You can use the terminal blocks to make your motor and motor power connections, or you can break off an 8×1 section of the 0.1" header strip and solder it into the smaller through-holes that border the four large motor and motor power pads. Note, however, that the terminal blocks are only rated for 16 A, and each header pin pair is only rated for a combined 6 A, so for higher-power applications, thick wires should be soldered directly to the board.

When not using this board as an Arduino shield, you can solder the 0.1" headers to the logic connections along the left side of the board to enable use with [custom cables](#) or [solderless breadboards](#), or you can solder wires directly to the board for more compact installations. Note that motor and motor power connections should not be made through a breadboard.

The motor driver includes three 47 uF electrolytic power capacitors, and there is room to add additional capacitors (e.g. to compensate for long power wires or increase stability of the power supply). Additional power capacitors are usually not necessary, and no additional capacitors are included with this motor driver.

The two mounting holes are intended for use with [#2 screws](#) (not included). They have a horizontal separation of 0.30" and a vertical separation of 1.70".

An [Arduino](#) is **not included**.

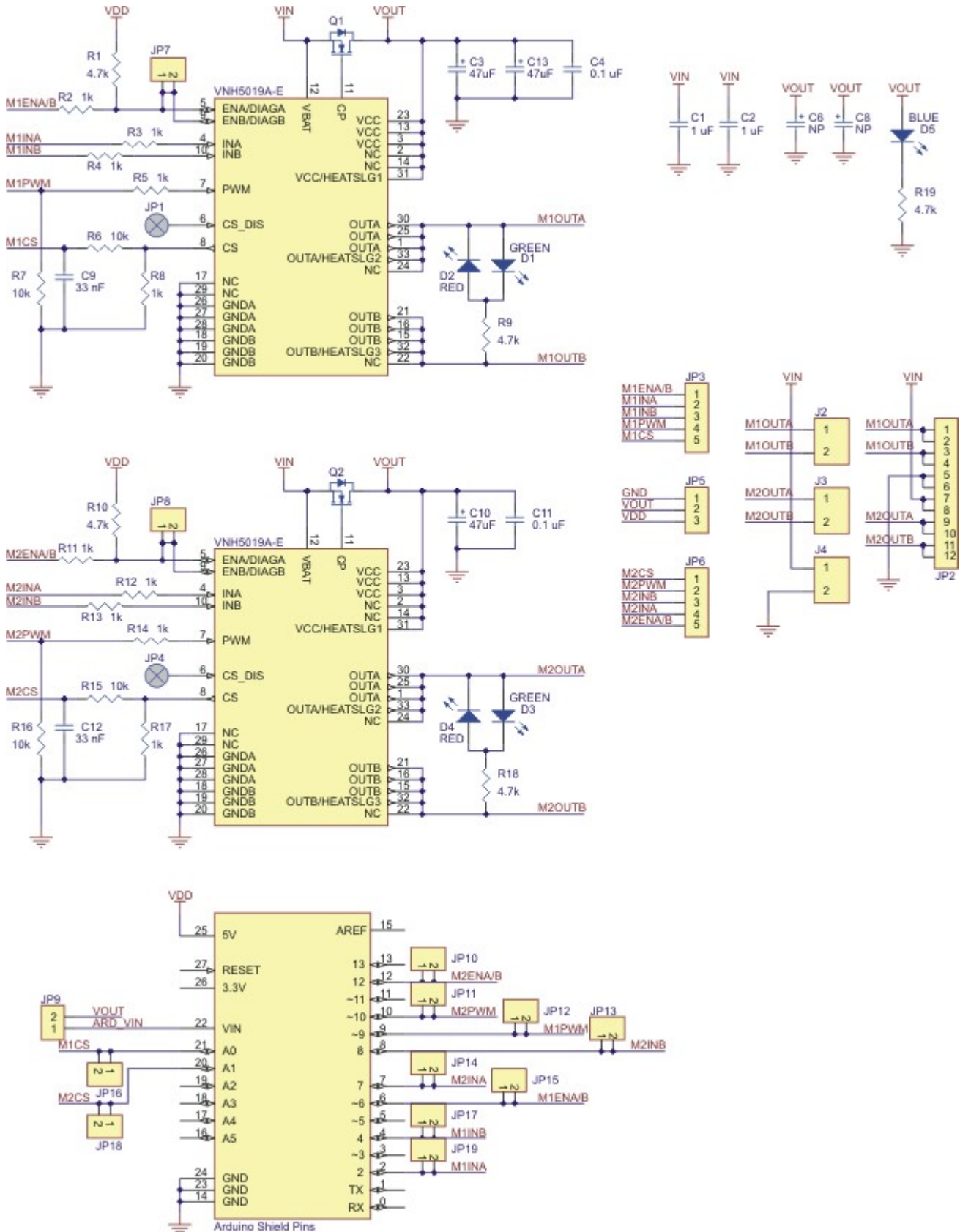

**Schematic diagram of the Pololu dual VNH5019 motor driver shield for Arduino.**

This schematic is also available as a downloadable pdf: [dual VNH5019 motor driver shield schematic](#) (87k pdf)

## ***VNH3SP30, VNH2SP30, and VNH5019 Comparison***

In addition to this VNH5019 shield, we offer carrier boards for two similar, older motor drivers from ST: the [VNH3SP30](#) and the [VNH2SP30](#). The VNH5019 is the only one of the three with a practical operating voltage above 16 V. The VNH5019 is the only driver of the three available on a Pololu Arduino shield.

The current-related values in the table below (i.e. the entries to which footnote 3 applies) are the results of tests on only one or two of each driver version, so they do not capture potential unit-to-unit variation, and they were performed using the [single driver versions](#), not the dual carriers. As such, the values should be treated as rough estimates of performance, not as performance guarantees. While these tests seem to indicate that the VNH2SP30 runs a bit cooler—and hence can deliver more continuous current—than the VNH5019, it is important to note that the three driver versions were tested at different times under potentially different conditions, so the results are not necessarily accurate indications of relative performance.

In our tests, we noticed that the thermal protection on the VNH5019 was activating at a lower temperature (153°C) than on the VNH2SP30 (170°C), which could partially account for the shorter VNH5019 overheating times. However, we also observed that the VNH5019 was reaching slightly higher temperatures than the VNH2SP30 when used under the same conditions: the VNH5019 reached a temperature of 85°C after 3 minutes at 10 A while the VNH2SP30 reached a temperature of 80°C.