

# RC Dinosaur

**Warning!** Not suitable for children under 36 months. Choking hazard. Only for use by children over 8 years old. To be used solely under the strict supervision of adults that have studied the precautions given in the experimental set. Hair entanglement may result if the child's head is too close to the motorized unit of this toy. This toy contains functional sharp point – on the component leads. Do not short-circuit the battery terminals and motors, which may cause overheating. Do not lock the motor or other moving parts, which may cause overheating. Use with care and only under supervision of adult.

Packaging materials are not toys. Please remove all packaging and packing tags/wires before giving this toy to your child.

**CAUTION!** Take extra care during unpacking and use.  
Please take note: As an extra precaution, check this toy regularly for signs of wear or damage. Read the instructions carefully before use, then follow them and keep them for reference.

**Warning!** Do not short-circuit the battery terminals and motor, which may cause overheating. The wires are not to be inserted into socket outlets.

**Batteries required: 6 x AAA/LR03 (Not included)**

**IMPORTANT: Keep these instructions. DO NOT DISCARD.**

1. Only adults should install and replace batteries.
2. Alkaline batteries are recommended.
3. If the device has not been used for a long time, remove the batteries.
4. Do not use rechargeable batteries.
5. Do not mix old and new batteries.
6. Do not mix alkaline, standard (carbon zinc) or rechargeable (nickel cadmium) batteries.
7. Exhausted batteries are to be removed from the toy.
8. Non-rechargeable batteries are not to be recharged.
9. The supply terminals are not to be short-circuited.
10. Only batteries of the same or equivalent type as recommended are to be used.
11. Batteries are to be inserted with the correct polarity.
12. Do not dispose of batteries in fire, batteries may explode or leak.
13. Batteries may explode or leak if misused.

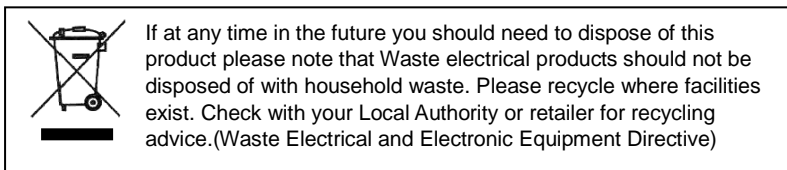

# Introduction

Almost every modern home has one or more remote control device, such as television or CD player. There are two major types of remote control, depending on the transmission signal used.

This RC robot uses the first type: infrared light (IR). It is commonly used for TV and home appliance control because of lower cost and it will not interfere with other radio devices. However, the range is short and the remote control must point at the device. In other words, the device must be able to “see” the control signal from the remote. Furthermore, it does not work well outdoors because the infrared part of sunlight will interfere the sensor.

The other type of remote control uses radio wave, it is often used in car security alarm, radio controlled planes and video game consoles, etc. They have the advantages of longer range, and will not be blocked by walls and objects in between. However, they are more expensive and may interfere with other radio devices.

## How does a remote control work?

Most control remotes for electronic appliances use a near infrared diode to emit a beam of light that reaches the device. This infrared light is invisible to the human eye, but picked up by sensors on the receiving device. Video cameras see the diode as if it produces visible purple light. The sensor converts the light pulses into electrical signal and passes it to the microprocessor which decodes them as commands, for example, to turn left or move forward.

### Components:

- 1 Chassis x1
- 2 Body frame x1
- 3 Dinosaur back x1
- 4 Front wheel x2
- 5 Rear wheel x2
- 6 Foreleg x2
- 7 Hind leg x2
- 8 Head x1
- 9 Exhaust pipe parts x4
- 10 Spike x1
- 11 Lever x4
- 12 Chassis part x2
- 13 Neck part x2
- 14 Wheel ring x2
- 15 Battery box x1
- 16 Switch x1
- 17 Switch cap x1
- 18 Long screw x4
- 19 Short screw x4
- 20 Remote control x1
- 21 Circuit board x1

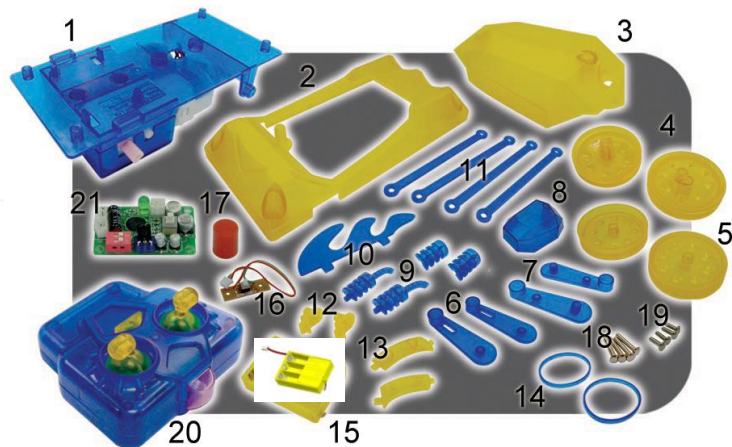

1 1 5 . 1

### Steps:

1. Insert the chassis part to the small slot on both sides of the chassis (1). (Fig. 2)

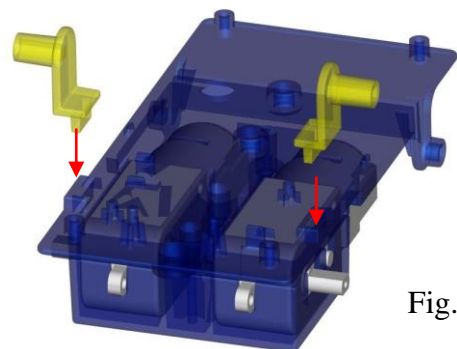

Fig. 2

2. Put the wheel rings (14) over the front wheels (4) and attach them to axles of the chassis (1). (Fig. 3, Fig. 4)



Fig. 3

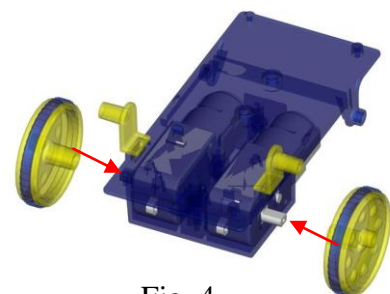

Fig. 4

3. Connect each hind leg (7) with the lever (11) using a short screw (19). (Fig. 5)



Fig. 5

4. Using the remaining long and short screws (18,19), connect the hind legs in last step and the remaining levers (11) and forelegs (6) to the chassis as shown in Fig. 6.

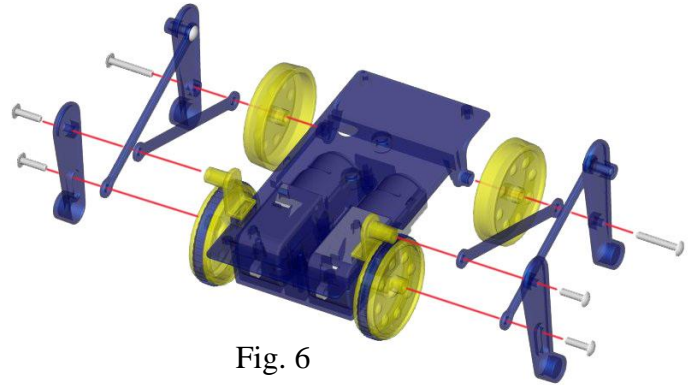

Fig. 6

5. Cover the switch (16) with the cap (17). Install the battery box (15), the switch (16) and the circuit board (21) on the chassis. See Fig. 7.

6. Connect the different plugs to the circuit board:
  - i. Battery - socket "BAT"
  - ii. Right motor - socket "M1"
  - iii. Left motor - socket "M2"
  - iv. Switch - socket "SW1".
 See Fig. 8.

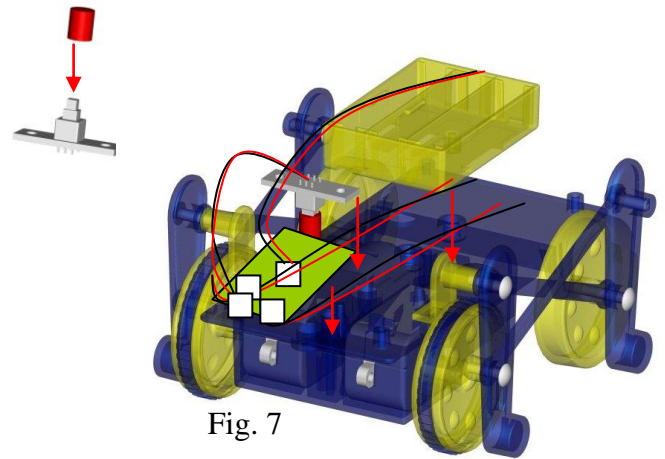

Fig. 7

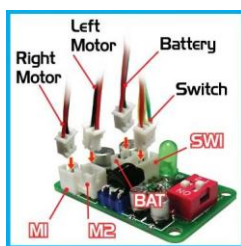

Fig. 8

7. Combine the neck parts (13). (Fig.9)

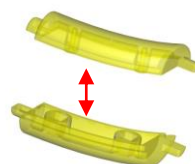

Fig. 9

8. Connect the spike (10) and the neck parts (13) to the dinosaur back (3). (Fig. 10)

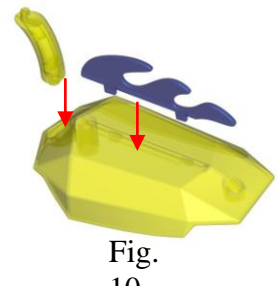
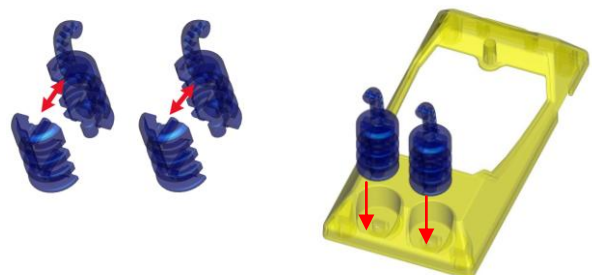

Fig. 10

9. Combine the exhaust pipe parts (9), as shown in Fig. 11.



10. Install the exhaust pipe into the body frame (2). (Fig.12)

11. Install the dinosaur back (3) on the body frame (2) and attach the head (8) as shown in Fig. 13 and Fig. 14.



Fig. 13

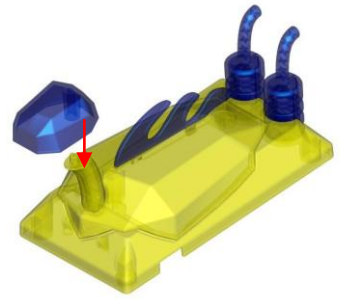

Fig. 14

12. Attach the body frame in the last step onto the chassis, as shown in Fig. 15.

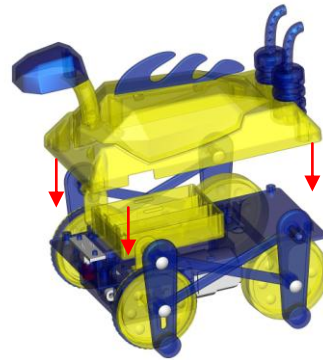

Fig. 15

13. Now you are done! Use a cross head screwdriver (not included) to loosen the screw in the battery compartment door of the battery box (15), install 3 AAA batteries according to the polarity mark. (Fig. 16) Replace the door and tighten the screw. Similarly, install 3 AAA batteries into the remote control (20) as shown in Fig. 17.

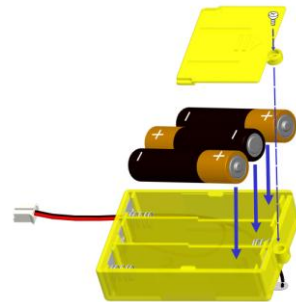

Fig. 16



Fig. 17

14. There is a channel select switch on the circuit board and the remote control. The remote control must be set to the same channel (1, 2 or 3) as the robot to be able to control it. If you are playing with your friends, each must choose a different channel so that one will not interfere with the other units. (Fig. 18)

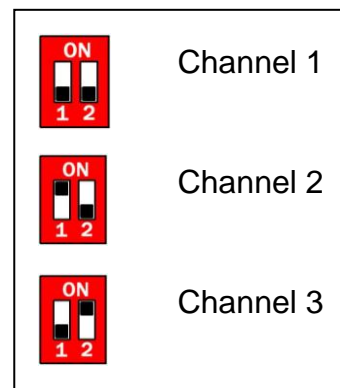

Fig. 18

15. Push the red power button on the robot **and the triangle button (A) on the remote control** to turn it on. Point the remote control towards the unit. Push both control sticks of the remote control forward or backward at the same time to move it in straight line. Move them in opposite directions to make a turn. (Fig. 19)

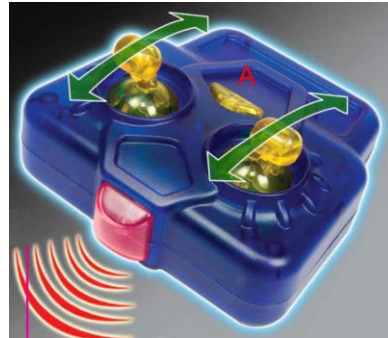

Fig. 19