

TOSHIBA TRANSISTOR SILICON NPN EPITAXIAL PLANAR TYPE

# 2SC2879

2~30MHz SSB LINEAR POWER AMPLIFIER APPLICATIONS  
(LOW SUPPLY VOLTAGE USE)

Unit in mm

- Specified 12.5V, 28MHz Characteristics
- Output Power :  $P_o = 100W_{PEP}$
- Power Gain :  $G_p = 13dB$
- Collector Efficiency :  $\eta_C = 35\%$  (Min.)
- Intermodulation Distortion :  $IMD = -24dB$  (Max.) (MIL Standard)

MAXIMUM RATINGS ( $T_c = 25^\circ C$ )

CHARACTERISTIC	SYMBOL	RATING	UNIT
Collector-Base Voltage	$V_{CBO}$	45	V
Collector-Emitter Voltage	$V_{CES}$	45	V
Collector-Emitter Voltage	$V_{CEO}$	18	V
Emitter-Base Voltage	$V_{EBO}$	4	V
Collector Current	$I_C$	25	A
Collector Power Dissipation	$P_C$	250	W
Junction Temperature	$T_j$	175	$^\circ C$
Storage Temperature Range	$T_{stg}$	-65~175	$^\circ C$

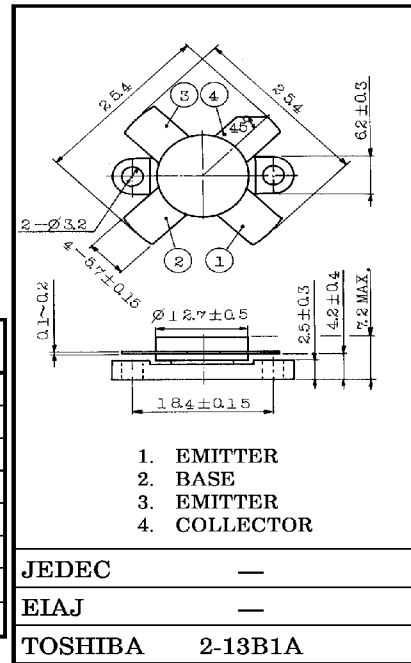

ELECTRICAL CHARACTERISTICS ( $T_c = 25^\circ C$ )

Weight : 5.2g

CHARACTERISTIC	SYMBOL	TEST CONDITION	MIN.	TYP.	MAX.	UNIT
Collector-Emitter Breakdown Voltage	$V_{(BR)CEO}$	$I_C = 100mA, I_B = 0$	18	—	—	V
Collector-Emitter Breakdown Voltage	$V_{(BR)CES}$	$I_C = 100mA, V_{EB} = 0$	45	—	—	V
Emitter-Base Breakdown Voltage	$V_{(BR)EBO}$	$I_E = 1mA, I_C = 0$	4	—	—	V
DC Current Gain	$h_{FE}$	$V_{CE} = 5V, I_C = 10A$	10	—	150	
Collector Output Capacitance	$C_{ob}$	$V_{CB} = 12.5V, I_E = 0$ $f = 1MHz$	—	700	—	pF
Power Gain	$G_p$	$V_{CC} = 12.5V, f_1 = 28.000MHz$	13.0	15.2	—	dB
Input Power	$P_i$	$f_2 = 28.001MHz$	—	6	10	$W_{PEP}$
Collector Efficiency	$\eta_C$	$I_{idle} = 100mA$	35	—	—	%
Intermodulation Distortion	IMD	$P_o = 100W_{PEP}$ (Fig.)	—	—	-24	dB
Series Equivalent Input Impedance	$Z_{in}$	$V_{CC} = 12.5V, f = 28MHz$	—	1.45 -j0.95	—	$\Omega$
Series Equivalent Output Impedance	$Z_{out}$	$\Delta f = 1kHz, P_o = 100W_{PEP}$	—	1.45 -j1.0	—	$\Omega$

**CAUTION**

Beryllia Ceramics is used in this product. The dust or vapor can be dangerous to humans. Do not break, cut, crush or dissolve chemically. Dispose of this properly according to law. Do not intermingle with normal industrial or domestic waste.

961001EAA2

- TOSHIBA is continually working to improve the quality and the reliability of its products. Nevertheless, semiconductor devices in general can malfunction or fail due to their inherent electrical sensitivity and vulnerability to physical stress. It is the responsibility of the buyer, when utilizing TOSHIBA products, to observe standards of safety, and to avoid situations in which a malfunction or failure of a TOSHIBA product could cause loss of human life, bodily injury or damage to property. In developing your designs, please ensure that TOSHIBA products are used within specified operating ranges as set forth in the most recent products specifications. Also, please keep in mind the precautions and conditions set forth in the TOSHIBA Semiconductor Reliability Handbook.
- The information contained herein is presented only as a guide for the applications of our products. No responsibility is assumed by TOSHIBA CORPORATION for any infringements of intellectual property or other rights of the third parties which may result from its use. No license is granted by implication or otherwise under any intellectual property or other rights of TOSHIBA CORPORATION or others.
- The information contained herein is subject to change without notice.

Fig. Pi TEST CIRCUIT

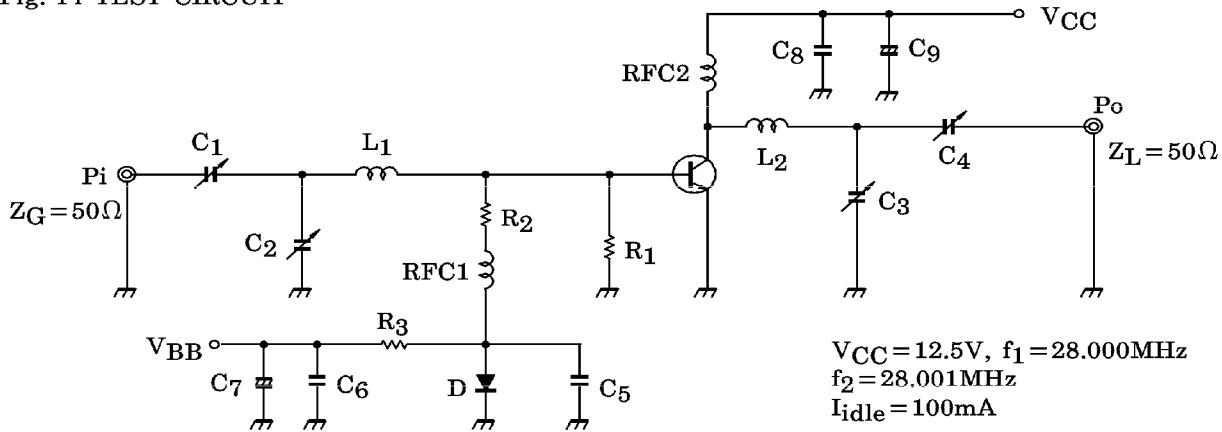

- |                            |  |
|----------------------------|--|
| $C_1, C_2$ : 7~150pF       | $L_1$ : $\phi 0.8$ ENAMEL COATED COPPER WIRE, 14ID, 4T, 4P                       |
| $C_3, C_4$ : 7~150pF 2KWV  | $L_2$ : $\phi 1.2$ ENAMEL COATED COPPER WIRE, 14ID, 3 1/2T, 3P                   |
| $C_5, C_6$ : 0.022 $\mu$ F | RFC1 : $\phi 0.8mm$ ENAMEL COATED COPPER WIRE, 10ID, 9T<br>(Ferrite Core TDK K2) |
| $C_7$ : 47 $\mu$ F 10WV    | RFC2 : $\phi 1.8mm$ ENAMEL COATED COPPER WIRE, 14ID, 20T                         |
| $C_8$ : 0.044 $\mu$ F      | $R_1$ : 10 $\Omega$ (1W)   |
| $C_9$ : 100 $\mu$ F 50WV   | $R_2$ : 2 $\Omega$ (1/2W)  |
|                            | $R_3$ : 10 $\Omega$ (5W)   |
|                            | D : 1S1555   |

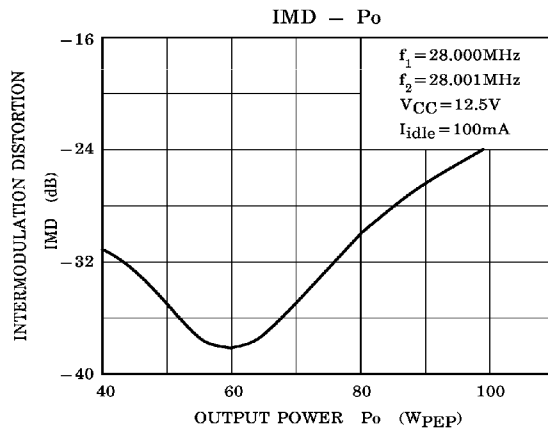
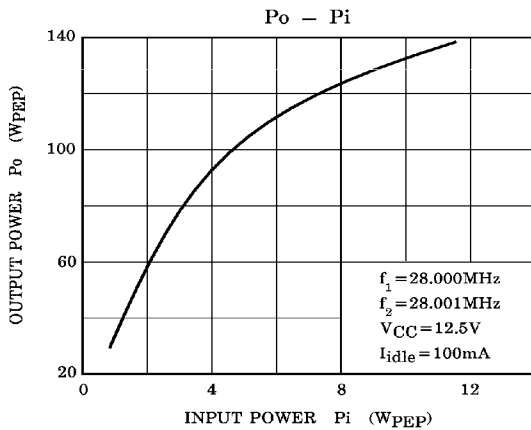

**CAUTION**

These are only typical curves and devices are not necessarily guaranteed at these curves.