

Representative 3 types of HUNO Arm Structure

- **Walking Type** : This arm type has the advantage of walking, and basic structure for RoboBuilder HUNO.
- **Dance Type** : This arm type has the advantage of various arm movement like Dancing.
- **Transformer Type** : This arm type makes to transform the HUNO into Wheel-Type Robot.

1) Walking type arm structure

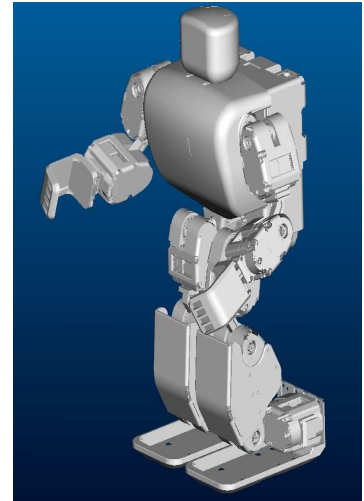
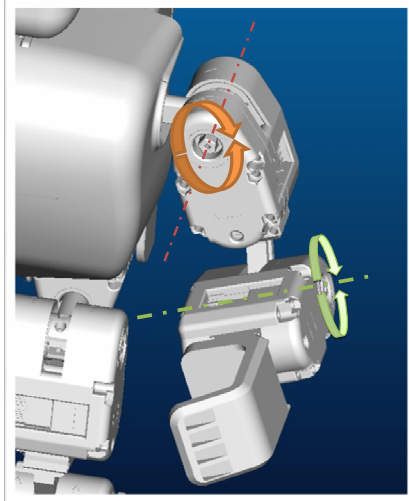
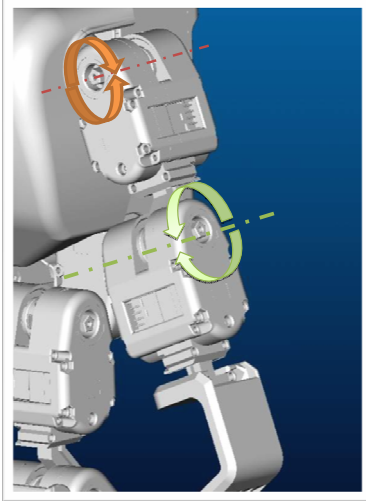

2) Dance type arm structure

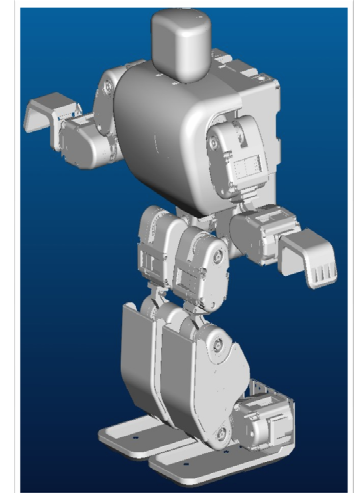
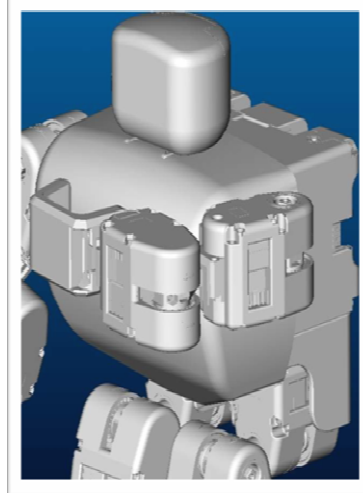
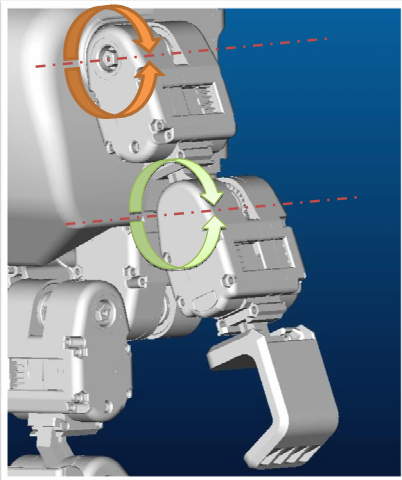

3) Transformer type arm structure

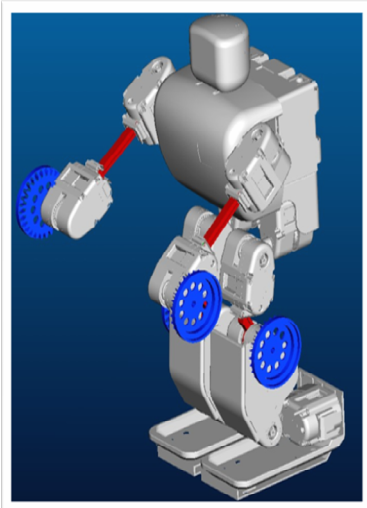

How to Change from Walking type to Dance type

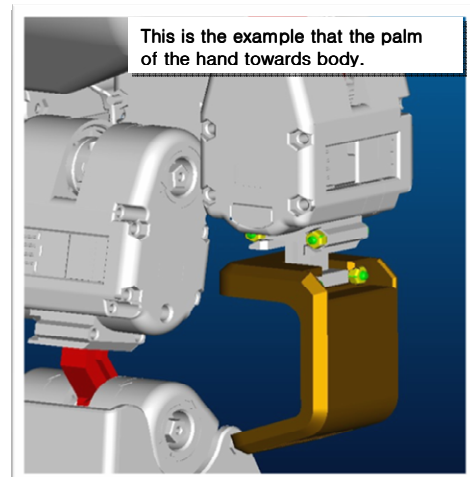
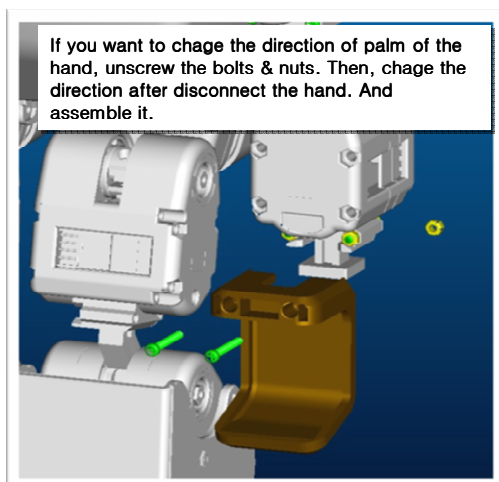
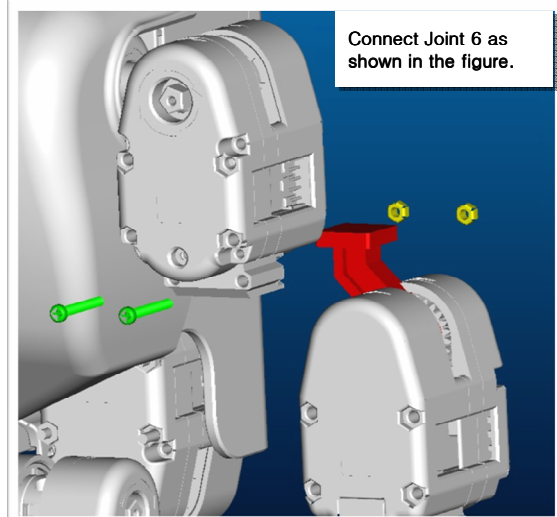
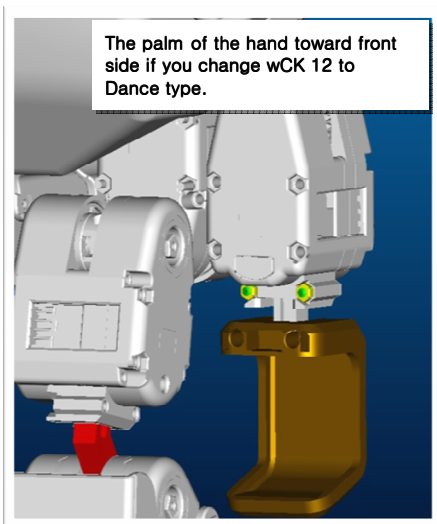
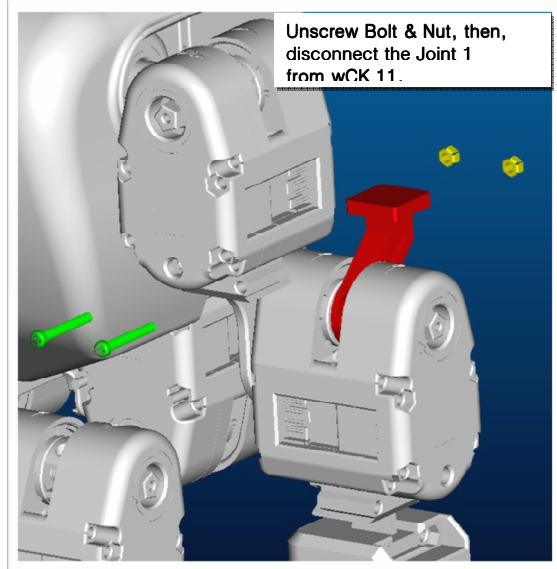
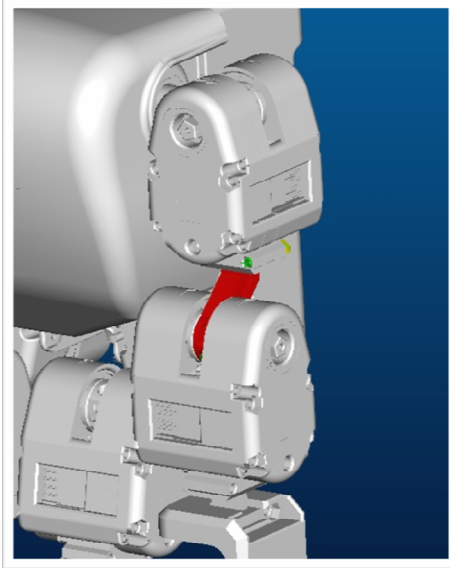

How to change from Walking type to Transformer type

