

# 4-channel BTL driver for CD players

## BA6793FP

The BA6793FP is a 4-channel BTL driver for CD player actuators and motors. This IC has an internal 5V regulator and a standard operational amplifier, making it suitable for a wide spectrum of applications.

### ●Applications

CD players, CD-ROM drives

### ●Features

- 1) 28-pin HSOP power package allows for application miniaturization.
- 2) Minimum attached components.
- 3) Driver gain is adjustable with a single attached resistor.
- 4) Internal 5V regulator. (requires attached PNP transistor)
- 5) Internal standard operational amplifier.
- 6) Internal thermal shutdown circuit.
- 7) Three separate power supplies.

### ●Absolute maximum ratings (Ta = 25°C)

Parameter	Symbol	Limits	Unit
Power supply voltage	V <sub>cc</sub>	18	V
Power dissipation	P <sub>d</sub>	1.7*1	W
Operating temperature	T <sub>opr</sub>	-35~+85	°C
Storage temperature	T <sub>stg</sub>	-55~+150	°C

\*1 Reduced by 13.6 mW for each increase in Ta of 1°C over 25°C.

When mounted on a 50 × 50 × 1 mm paper phenol board.

### ●Recommended operating conditions (Ta = 25°C)

Parameter	Symbol	Limits	Unit
Power supply voltage	V <sub>cc</sub>	6~14*2	V

\*2 The driver can operate as low as 4.5 V.

●Block diagram

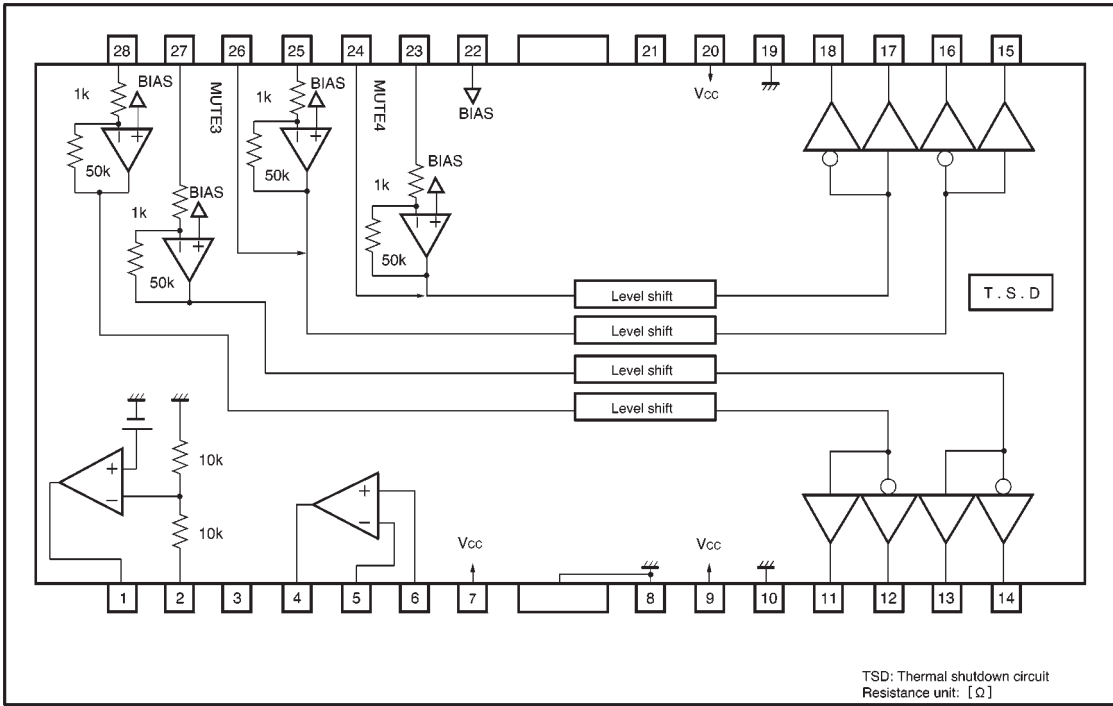

●Pin descriptions

Pin No.	Pin name	Function
1	REG - B	Connect to the base of the attached transistor
2	REG OUT	Constant voltage output (connect to the collector of the attached transistor)
3	—	N.C.
4	OP OUT	Operational amplifier output
5	OP IN(-)	Operational amplifier negative input
6	OP IN(+)	Operational amplifier positive input
7	Vcc	Vcc (operational amplifier, reg., etc.)
8	GND	Substrate ground
9	Vcc D1	Driver Vcc (channels 1 and 2)
10	GND D1	Driver ground (channels 1 and 2)
11	VO1-	Channel 1 negative output
12	VO1+	Channel 1 positive output
13	VO2-	Channel 2 negative output
14	VO2+	Channel 2 positive output

Pin No.	Pin name	Function
15	VO3-	Channel 3 negative output
16	VO3+	Channel 3 positive output
17	VO4-	Channel 4 negative output
18	VO4+	Channel 4 positive output
19	GND D2	Driver ground (channels 3 and 4)
20	Vcc D2	Driver Vcc (channels 3 and 4)
21	—	N.C.
22	BIAS IN	Bias input
23	VIN4	Channel 4 input
24	MUTE4	Channel 4 mute
25	VIN3	Channel 3 input
26	MUTE3	Channel 3 mute
27	VIN2	Channel 2 input
28	VIN1	Channel 1 input

Note: positive and negative output of the driver is relative to the polarity of the input pins.  
When the input pin is at the high level, the negative output pin is at the low level and the positive output pin is at the high level.

● Pin equivalent circuit diagrams

Driver input

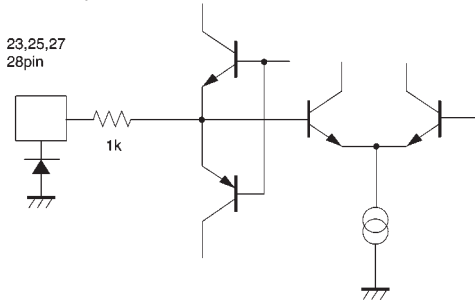

Driver output

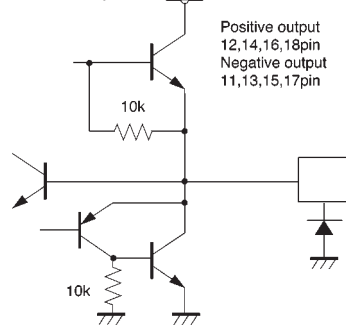

Bias

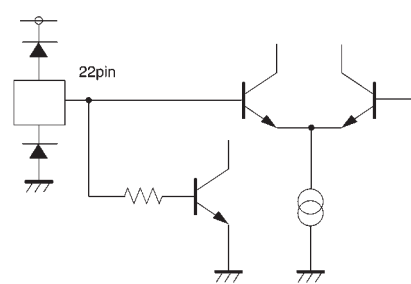

Regulator (base connection)

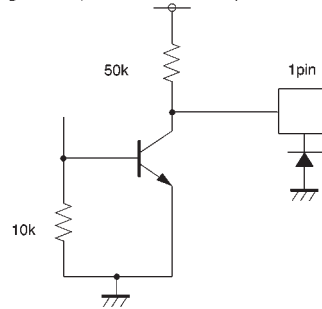

Mute

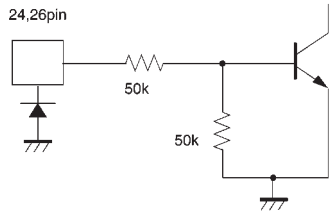

Regulator output

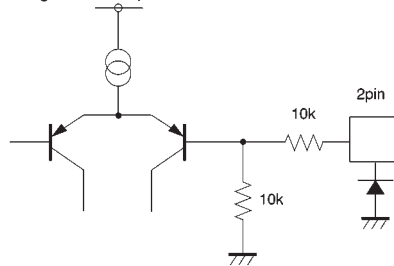

Operational amplifier input

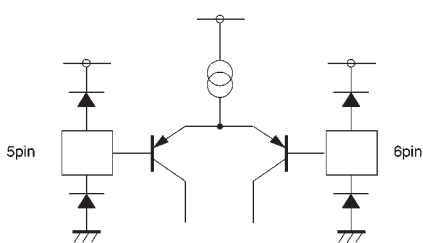

Operational amplifier output

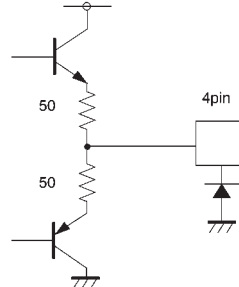

Resistance unit: [Ω]

- Electrical characteristics (unless otherwise noted,  $T_a = 25^\circ\text{C}$ ,  $V_{CC} = 12\text{V}$ ,  $\text{BIAS} = 2.5\text{V}$ ,  $f = 1\text{kHz}$ ,  $R_{IN} = 20\text{k}\Omega$ ,  $R_L = 8\Omega$ )

Parameter	Symbol	Min.	Typ.	Max.	Unit	Conditions
Quiescent current dissipation	$I_{CC}$	—	11.0	15.0	mA	No load
Output voltage, offset	$V_{OO}$	-90	—	90	mV	
Maximum output amplitude	$V_{OM}$	7.5	8.3	—	V	
Closed loop voltage gain	$G_{VC}$	12.0	14.0	16.0	dB	$V_{IN} = \text{BIAS} + 0.15\text{V}$
Ripple rejection	$RR$	—	60	—	dB	$V_{IN} = 0.1V_{rms}$ , 100Hz
Slew rate	$SR$	—	2.0	—	$V/\mu\text{s}$	100 kHz square wave, 3 $V_{P-P}$ output
Mute On voltage	$V_{MON}$	2.0	—	—	V	
Mute Off voltage	$V_{MOFF}$	—	—	0.5	V	
〈5 V regulator〉						
Output voltage	$V_{REG}$	4.75	5.00	5.25	V	$I_L = 100\text{mA}$
Output load differential	$\Delta V_{RL}$	-50	0	10	mV	$I_L = 0 \sim 200\text{mA}$
Power supply voltage differential	$\Delta V_{VCC}$	-15	21	60	mV	$(V_{CC} = 6 \sim 14\text{V}) I_L = 100\text{mA}$
〈Operational amplifier〉						
Offset voltage	$V_{OFOP}$	-5	0	5	mV	
Input bias current	$V_{BOP}$	—	—	300	nA	
Output high level voltage	$V_{OHOP}$	10.5	11.4	—	V	
Output low level voltage	$V_{OLOP}$	—	0.74	1.1	V	
Output drive current (sink)	$I_{SINK}$	-200	0	200	mA	$I_L = 10\text{mA}$
Output drive current (source)	$I_{SOURCE}$	-200	0	200	mA	$I_L = -10\text{mA}$
Open loop voltage gain	$G_{VO}$	—	78	—	dB	$V_{IN} = -75\text{dBV}$ , 1kHz
Slew rate	$S_{ROP}$	—	1	—	$V/\mu\text{s}$	100 kHz square wave, 4 $V_{P-P}$ output
Ripple rejection	$R_{ROP}$	—	65	—	dB	$V_{IN} = -20\text{dBV}$ , 100Hz
Common mode rejection ratio	$CMRR$	—	84	—	dB	$V_{IN} = -20\text{dBV}$ , 1kHz

©Not designed for radiation resistance.

● Measurement circuit

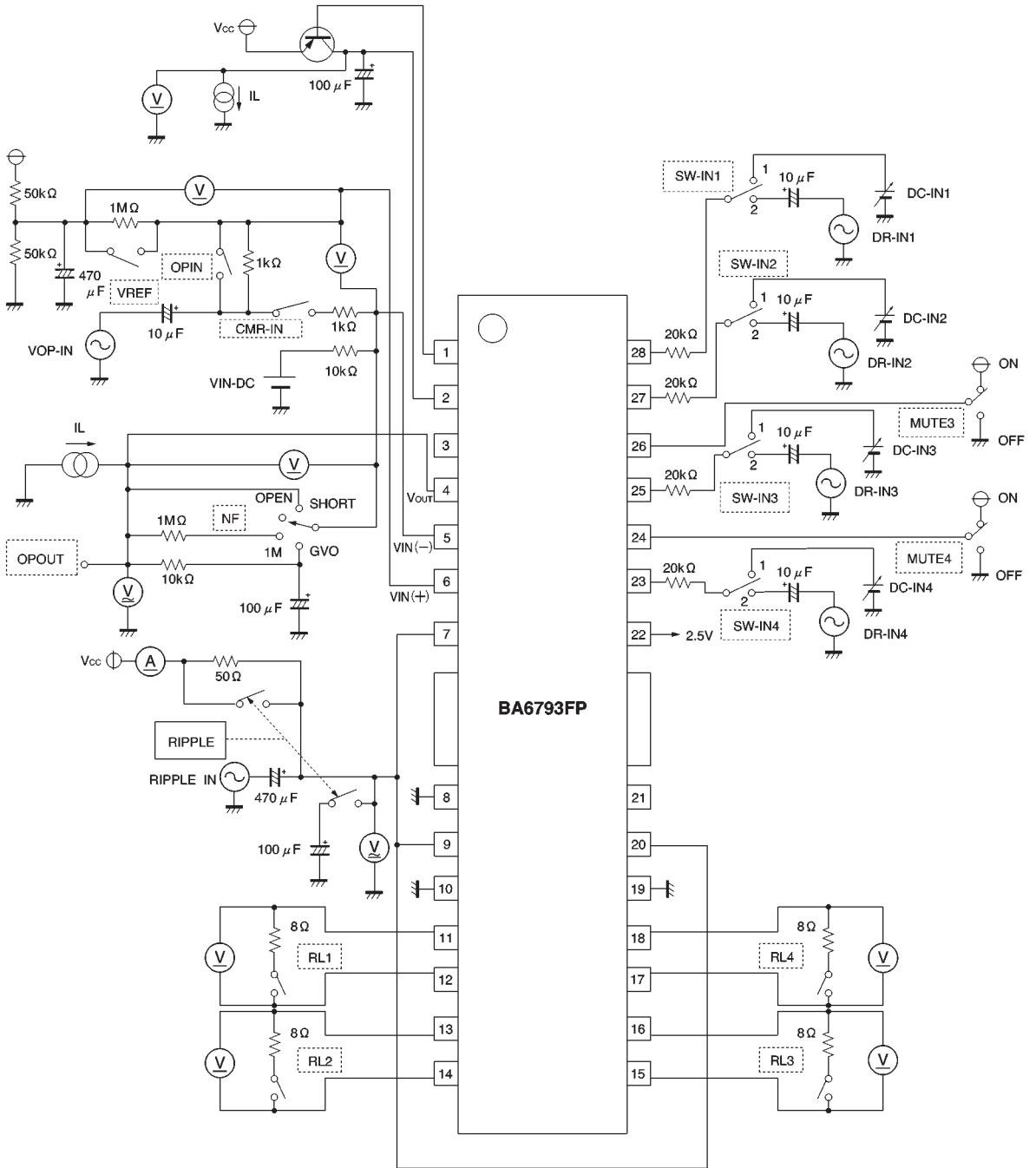

Fig. 1

● Circuit operation

(1) Driver

Inputs to the IC are the focus tracking error signal from the servo preamplifier and the control signal from the motor. The input signals, which normally center on 2.5V, are V / I converted by the preamplifier, generating a current corresponding to the input voltage. This current is

passed through a resistor and into the internal reference voltage component, the preamplifier output being a signal centering on the internal reference voltage. Two systems (positive phase and negative phase) are created during V / I conversion, generating BTL output via the driver buffer.

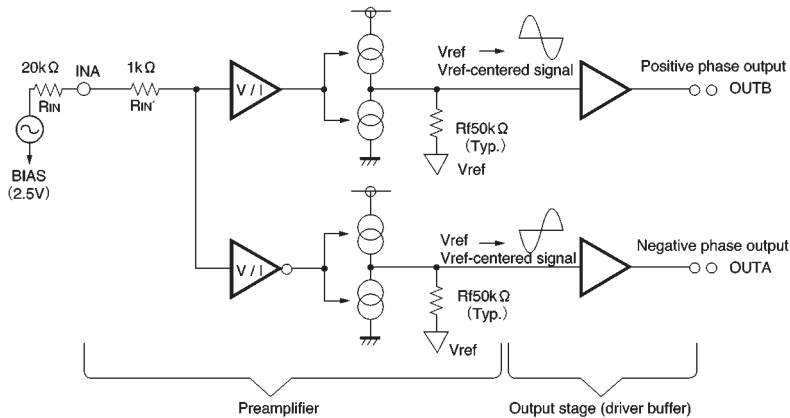

Fig. 2

(2) Regulator

This is a typical series regulator that generates a reference voltage internally. A PNP low saturation transistor must be connected.

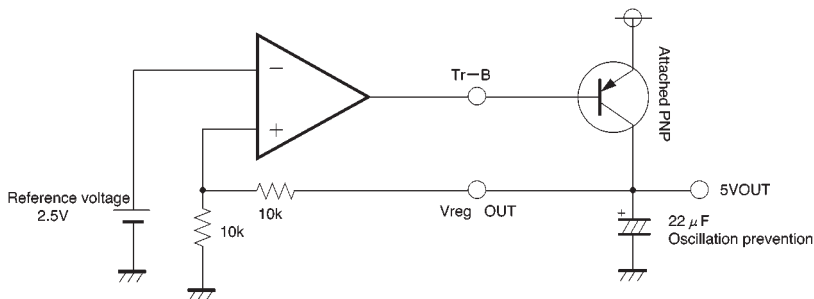

Fig. 3

(3) Operational amplifier

A standard 4558 type.

● Application example

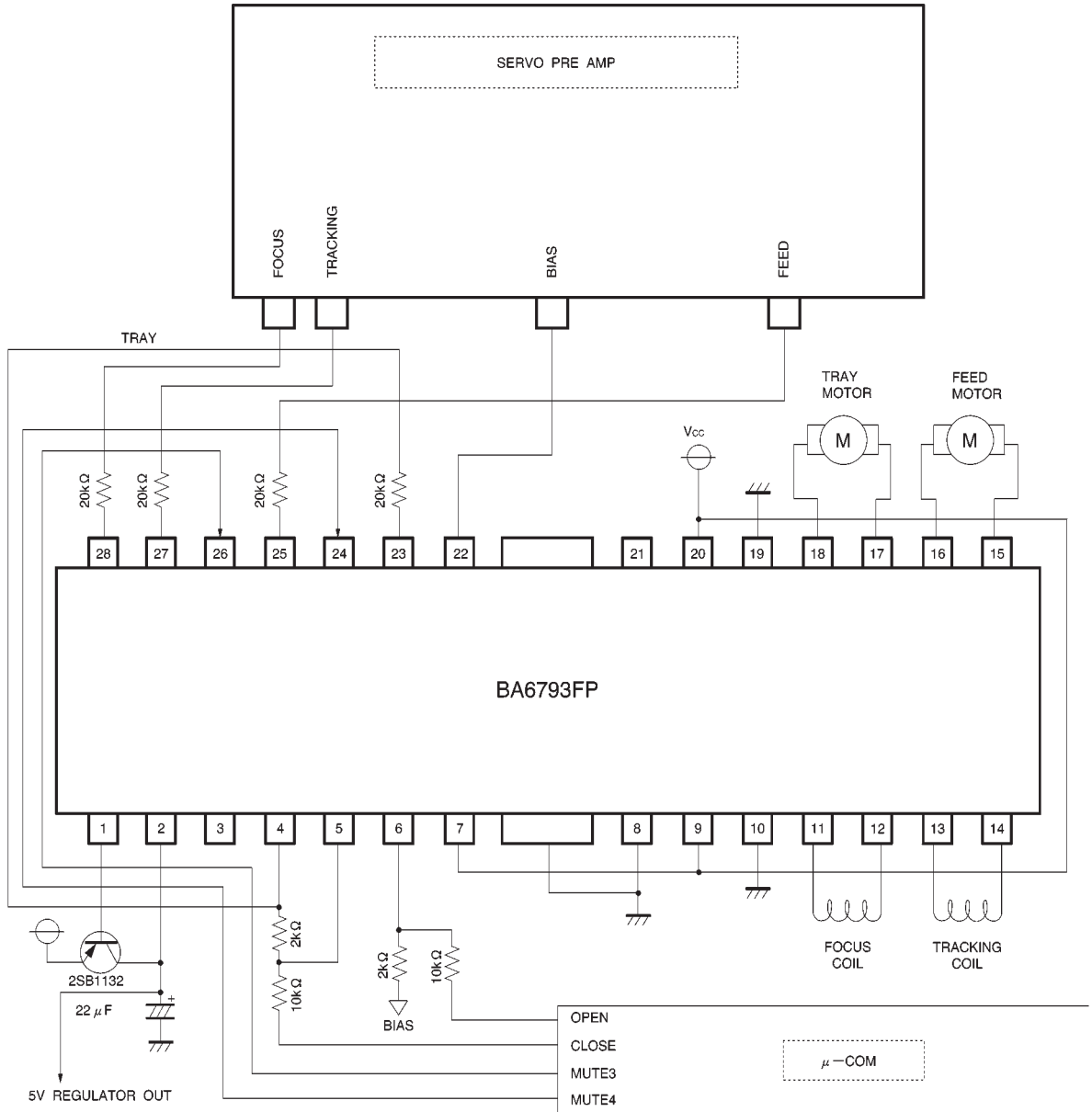

Fig. 4

● Operation notes

- (1) The BA6793FP has a thermal shutdown circuit. The output current is muted when the chip temperature rises above 175°C (typically). When the chip temperature falls to 150°C (typically), the driver circuit starts up again.
- (2) The output currents (channels 3 and 4) can be muted by pulling up the mute pins (pins 24 and 26) above 2.0V. During ordinary use, pins 24 and 26 should be left open or lowered below 0.5V.
- (3) Muting also occurs when the bias pin (pin 22) drops below 1.4V (typically). Make sure it stays above 2.0V during normal use.

- (4) Muting occurs during thermal shutdown, mute-on operations or a drop in the bias pin voltage. In each case, only the drivers are muted. During muting, the output pins remain at the internal bias voltage, roughly  $(V_{CC} - V_F) / 2$ .
- (5) Connect the IC to a 1μF bypass capacitor between power supplies, at the base of the IC.
- (6) The radiating fin is connected to the package's internal GND, but should also be connected to an external ground.
- (7) The capacitor between regulator output (pin 2) and GND also serves to prevent oscillation of the IC, so select one with good temperature characteristics.

● Electrical characteristic curves

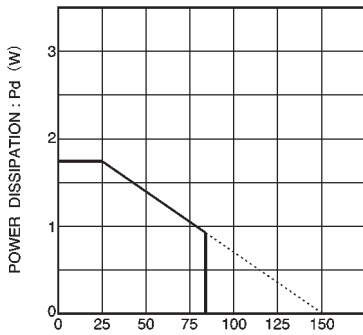

AMBIENT TEMPERATURE : Ta (°C)  
When mounted on a 50 × 50 × 1 mm paper phenol board.  
Fig. 5 Thermal derating curve

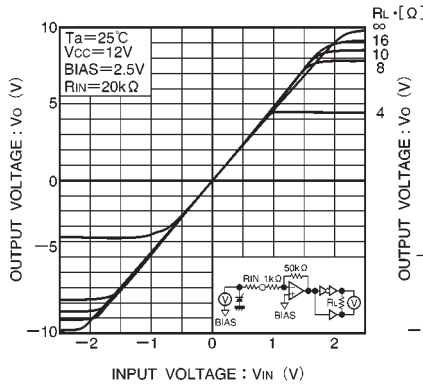

Fig. 6 Driver I/O characteristics (variable load)

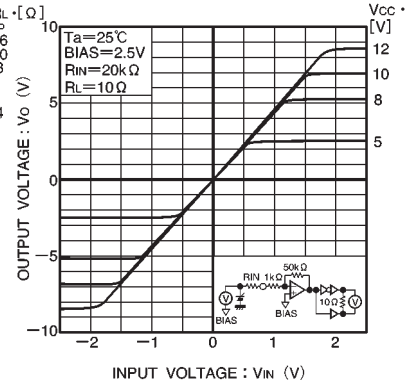

Fig. 7 Driver I/O characteristics (variable Vcc)

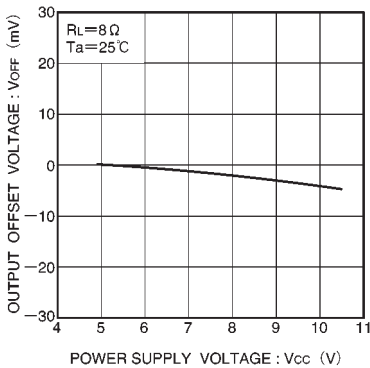

Fig. 8 Power supply voltage vs. output offset voltage

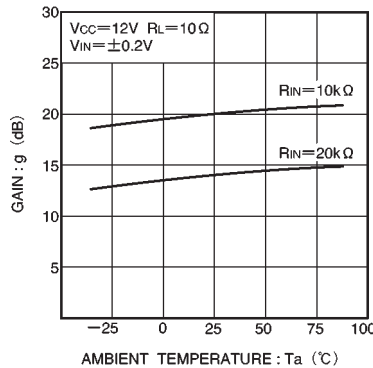

Fig. 9 Driver gain vs. temperature

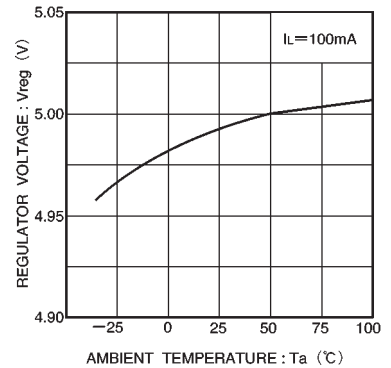

Fig. 10 Regulator voltage vs. temperature



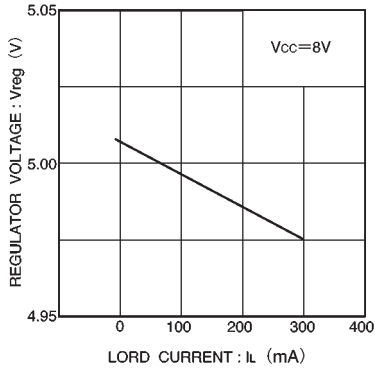

Fig. 11 Load current vs. regulator voltage

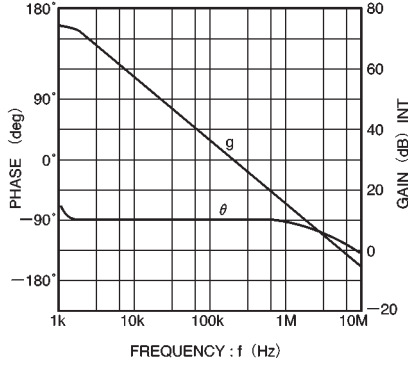

Fig. 12 Operational amplifier vs. open loop

● External dimensions (Units: mm)

