



MEAN WELL

SWITCHING POWER SUPPLY
ISO-9001 CERTIFIED MANUFACTURER

D-60 SERIES

- .LOW COST, HIGH RELIABILITY
- .105°C OUTPUT CAPACITOR
- .INTERNATIONAL AC INPUT RANGE
- .HIGH EFFICIENCY, LOW WORKING TEMPERATURE
- .SOFT-START CIRCUIT, LIMITING AC SURGE CURRENT
- .SHORT CIRCUIT, OVERLOAD, OVER VOLTAGE PROTECTED
- .COMPACT SIZE, LIGHT WEIGHT
- .100% FULL LOAD BURN-IN TEST
- .BUILT IN EMI FILTER, LOW RIPPLE NOISE

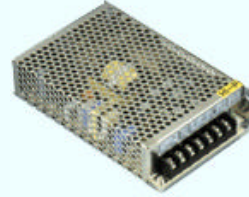

SPECIFICATION	D-60A		D-60B	
	CH1	CH2	CH1	CH2
DC OUTPUT VOLTAGE	5V	12V	5V	24V
OUTPUT V. TOLERANCE	±2%	±6%	±2%	±5%
OUTPUT RATED CURRENT	4A	3A	3A	1.8A
OUTPUT CURRENT RANGE	0.3-6A	0.2-4A	0.3-6A	0.2-2.2A
RIPPLE & NOISE	75mVp-p	150mVp-p	75mVp-p	150mVp-p
LINE REGULATION	±0.5%	±1%	±0.5%	±0.5%
LOAD REGULATION	±0.5%	±4%	±0.5%	±4%
DC OUTPUT POWER	56W		58W	
EFFICIENCY	73%		76%	
DC VOLTAGE ADJ.	CH1:±10,-5%		CH1:±10,-5%	
INPUT VOLTAGE RANGE	85~264VAC 47~63Hz; 120~370VDC			
AC CURRENT	2A/115V 1A/230V			
INRUSH CURRENT	COLD START 30A/115V 60A/230V			
LEAKAGE CURRENT	<1mA/240VAC			
OVERLOAD PROTECTION	105%~150% TYPE:PULSING HICCUP SHUTDOWN RESET:AUTO RECOVERY			
OVER VOLTAGE PROTECTION	CH1:5.75~6.75V			
OVER TEMP. PROTECTION	-----			
TEMP. COEFFICIENT	±0.03% / °C (0~50°C) ON +5V OUTPUT			
SETUP, RISE, HOLD UP TIME	800ms, 50ms, 10ms / 115VAC 300ms, 50ms, 80ms / 230VAC			
VIBRATION	10~500Hz, 2G 10min./1cycle, PERIOD FOR 60min. EACH AXES			
WITHSTAND VOLTAGE	I/P-O/P:3KVAC I/P-FG:1.5KVAC O/P-FG:0.5KVAC			
ISOLATION RESISTANCE	I/P-O/P, I/P-FG, O/P-FG:500VDC / 100M Ohms			
WORKING TEMP., HUMIDITY	-10°C~+60°C(REFER TO OUTPUT DERATING CURVE), 20%~90% RH			
STORAGE TEMP., HUMIDITY	-20°C~+85°C, 10%~95% RH			
DIMENSION	159*97*38mm CASE:901			
WEIGHT	0.55Kgs			
SAFETY STANDARDS	UL1012, TUV EN60950, IEC950, UL1950 APPROVED			
EMC STANDARDS	CISPR22 (EN55022) CLASS B, IEC801-2,3,4, IEC555-2 VERIFICATION			

- NOTE :
- 1.ALL PARAMETERS ARE SPECIFIED AT 230VAC INPUT, RATED LOAD, 25°C 70% RH. AMBIENT.
 - 2.TOLERANCE GINCLUDE SET UP TOLERANCE, LINE REGULATION, LOAD REGULATION.
 - 3.RIPPLE & NOISE ARE MEASURED AT 20MHz BY USING A 12" TWISTED PAIR TERMINATED WITH A 0.1uF & 47uF CAPACITOR.
 - 4.LINE REGULATION IS MEASURED FROM LOW LINE TO HIGH LINE AT RATED LOAD.
 - 5.LOAD REGULATION IS MEASURED FROM 20% TO 100% RATED LOAD, AND OTHER OUTPUT AT 60% RATED LOAD.
 - 6.EACH OUTPUT PROVIDE UP TO MAXIMUM CURRENT, BUT TOTAL LOAD CAN NOT EXCEED MAX. OUTPUT POWER.
 - 7.C2,3,6 MUST BE REMOVED.

BLOCK DIAGRAM

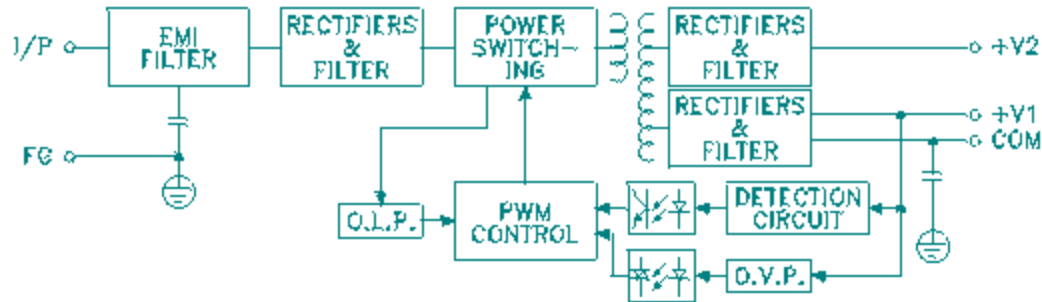

$f_{osc} = 54\text{KHz}$

OUTPUT DERATING

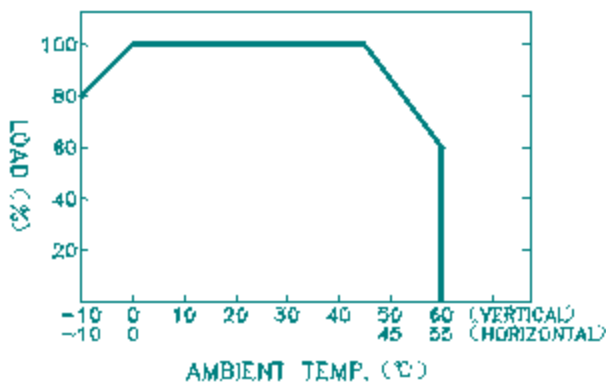

STATIC CHARACTERISTICS

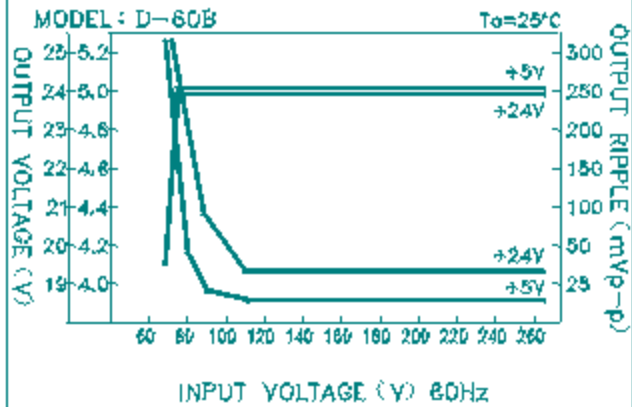

DIMENSION (mm)

- ☒ CASE : 901
- ☒ TERMINAL PIN NO. ASSIGNMENT
- ☒ PIN 1,2 : AC INPUT
- ☒ PIN 3 : FG \oplus
- ☒ PIN 4 : DC OUTPUT +V2
- ☒ PIN 5 : DC OUTPUT +V1
- ☒ PIN 6,7 : DC OUTPUT COM

