

## Features

- High Efficiency (Up to 84%)
- Active Power Factor Correction (Typical 0.92)
- Constant Output Current
- Waterproof (IP66)
- Dimming Control
- All-Round Protection: OVP, SCP, OLP
- Comply With UL8750 & EN61347 Safety Regulations
- Comply With ANSI/IEEE C62.41, Class A Operation



## Description

The EUC-025SxxxDS/PS Series operate from a 90 ~ 305 Vac input range. These units will provide up to a 2080 mA of output current and a maximum output voltage of 72 V for 25 W maximum output power. They are designed to be highly efficient and highly reliable. Features include over voltage protection, short circuit protection and over load protection.

## Models

Output Current	Input Voltage	Max. Output Voltage	Max. Output Power	Typical Efficiency (1)	Power Factor		Model Number With Dimming Control (2, 3)	Model Number Without Dimming Control (2, 3)
					110Vac	220Vac		
2080 mA	90 ~ 305 Vac	12 Vdc	25 W	80%	0.98	0.92	EUC-025S208DS(6)	EUC-025S208PS(6)
1750 mA	90 ~ 305 Vac	14 Vdc	25 W	81%	0.98	0.92	EUC-025S175DS(6)	EUC-025S175PS(6)
1400 mA	90 ~ 305 Vac	18 Vdc	25 W	81%	0.98	0.92	EUC-025S140DS(6)	EUC-025S140PS(6)
1050 mA	90 ~ 305 Vac	24 Vdc	25 W	82%	0.98	0.92	EUC-025S105DS(6)★	EUC-025S105PS(6)★
700 mA	90 ~ 305 Vac	36 Vdc	25 W	83%	0.98	0.92	EUC-025S070DS(6)★	EUC-025S070PS(6)★
620 mA	90 ~ 305 Vac	40 Vdc	25 W	83%	0.98	0.92	EUC-025S062DS(5)	EUC-025S062PS(5)
450 mA	90 ~ 305 Vac	56 Vdc	25 W	84%	0.98	0.92	EUC-025S045DS(5)	EUC-025S045PS(5)
350 mA	90 ~ 305 Vac	72 Vdc	25 W	84%	0.98	0.92	EUC-025S035DS(4)★	EUC-025S035PS(4)★

- Notes:**
- (1) Measured at full load and 220 Vac input.
  - (2) The DS suffix may be changed to PS to omit the dimming function and remove the three wires associated with that function.
  - (3) A suffix –xxx may be added to denote variations or modifications to the base product, where x can be any alphanumeric character or blank.
  - (4) Non-Class 2 output (USR & CNR).
  - (5) Class 2 output (USR), Non-Class 2 output (CNR).
  - (6) Class 2 output (USR & CNR).
  - (7) ★: Popular model.

## Input Specifications

Parameter	Min.	Typ.	Max.	Notes
Input Voltage	90 V	-	305 V	
Input Frequency	47Hz	-	63 Hz	
Leakage Current	-	-	0.5 mA	At 277Vac 50Hz input
Input AC Current	-	-	0.32 A	Measured at full load and 100 Vac input.
	-	-	0.15 A	Measured at full load and 220 Vac input.
Inrush Current	-	-	60 A	At 230Vac input 25°C Cold Start .

Specifications are subject to changes without notice.

## Output Specifications

Parameter	Min.	Typ.	Max.	Notes
Output Current Range				
$I_o = 2080 \text{ mA}$	1976 mA	-	2184 mA	
$I_o = 1750 \text{ mA}$	1663 mA	-	1838 mA	
$I_o = 1400 \text{ mA}$	1330 mA	-	1470 mA	
$I_o = 1050 \text{ mA}$	998 mA	-	1103 mA	
$I_o = 700 \text{ mA}$	665 mA	-	735 mA	
$I_o = 620 \text{ mA}$	589 mA	-	651 mA	
$I_o = 450 \text{ mA}$	428 mA	-	473 mA	
$I_o = 350 \text{ mA}$	333 mA	-	368 mA	
Output Voltage Range				
$I_o = 2080 \text{ mA}$	4 V	-	12 V	
$I_o = 1750 \text{ mA}$	5 V	-	14 V	
$I_o = 1400 \text{ mA}$	6 V	-	18 V	
$I_o = 1050 \text{ mA}$	8 V	-	24 V	
$I_o = 700 \text{ mA}$	12 V	-	36 V	
$I_o = 620 \text{ mA}$	13 V	-	40 V	
$I_o = 450 \text{ mA}$	19 V	-	56 V	
$I_o = 350 \text{ mA}$	24 V	-	72 V	
No Load Output Voltage				
$I_o = 2080 \text{ mA}$	-	-	16 V	
$I_o = 1750 \text{ mA}$	-	-	18 V	
$I_o = 1400 \text{ mA}$	-	-	22 V	
$I_o = 1050 \text{ mA}$	-	-	30 V	
$I_o = 700 \text{ mA}$	-	-	42 V	
$I_o = 620 \text{ mA}$	-	-	48 V	
$I_o = 450 \text{ mA}$	-	-	61 V	
$I_o = 350 \text{ mA}$	-	-	79 V	
Ripple & Noise				
$I_o = 2080 \text{ mA}$	-	-	3 V	Measurement is done by 20MHz bandwidth oscilloscope and the output paralleled a 104/500V ceramic capacitor and a 10uF/200V electrolysis capacitor
$I_o = 1750 \text{ mA}$	-	-	3 V	
$I_o = 1400 \text{ mA}$	-	-	3 V	
$I_o = 1050 \text{ mA}$	-	-	3 V	
$I_o = 700 \text{ mA}$	-	-	4 V	
$I_o = 620 \text{ mA}$	-	-	4 V	
$I_o = 450 \text{ mA}$	-	-	4 V	
$I_o = 350 \text{ mA}$	-	-	5 V	
Line Regulation	-	-	3%	
Load Regulation	-	-	5%	
Turn-on Delay Time	-	2.5 S	3.0 S	Measured at 110Vac input.
	-	1.5 S	2.0 S	Measured at 220Vac input.

**Note:** All specifications are typical at 25 °C unless otherwise stated.

Specifications are subject to changes without notice.

## Protection Functions

Parameter	Min.	Typ.	Max.	Notes
Over Voltage Protection				Hiccup mode. The power supply shall be self-recovery when the fault condition is removed.
$I_o = 2080 \text{ mA}$	13 V	15 V	18 V	
$I_o = 1750 \text{ mA}$	16 V	18 V	20 V	
$I_o = 1400 \text{ mA}$	21 V	23 V	24 V	
$I_o = 1050 \text{ mA}$	26 V	28 V	30 V	
$I_o = 700 \text{ mA}$	42 V	44 V	46 V	
$I_o = 620 \text{ mA}$	44 V	46 V	48 V	
$I_o = 450 \text{ mA}$	59 V	50 V	62 V	
$I_o = 350 \text{ mA}$	82 V	88 V	90 V	
Over Load Protection	-	1.25 Vmax	-	Hiccup mode. The power supply shall be self-recovery when the fault condition is removed.
Short Circuit Protection	No damage shall occur when any output operating in a short circuit condition. The power supply shall be self-recovery when the fault condition is removed.			

## General Specifications

Parameter	Min.	Typ.	Max.	Notes
Efficiency				Measured at full load and 110 Vac input.
$I_o = 2080 \text{ mA}$	78%	79%	-	
$I_o = 1750 \text{ mA}$	79%	80%	-	
$I_o = 1400 \text{ mA}$	79%	80%	-	
$I_o = 1050 \text{ mA}$	80%	81%	-	
$I_o = 700 \text{ mA}$	81%	82%	-	
$I_o = 620 \text{ mA}$	81%	82%	-	
$I_o = 450 \text{ mA}$	82%	83%	-	
$I_o = 350 \text{ mA}$	82%	83%	-	
Efficiency				Measured at full load and 220 Vac input.
$I_o = 2080 \text{ mA}$	79%	80%	-	
$I_o = 1750 \text{ mA}$	80%	81%	-	
$I_o = 1400 \text{ mA}$	80%	81%	-	
$I_o = 1050 \text{ mA}$	81%	82%	-	
$I_o = 700 \text{ mA}$	82%	83%	-	
$I_o = 620 \text{ mA}$	82%	83%	-	
$I_o = 450 \text{ mA}$	83%	84%	-	
$I_o = 350 \text{ mA}$	83%	84%	-	
No Load Power Dissipation	≤ 6 W			
MTBF	484,000 hours			For 2080 mA output model, measured at 110Vac input, 80%Load and 25°C ambient temperature (MIL-HDBK-217F).
Life Time	79,000 hours			For 2080 mA output model, measured at 110Vac input, 80%Load and 45°C ambient temperature
Dimensions				
Inches (L x W x H)	3.07 x 3.15 x 1.06			
Millimeters (L x W x H)	78 x 80 x 27			
Net Weight	-	200 g	-	

**Note:** All specifications are typical at 25 °C unless otherwise stated.

Specifications are subject to changes without notice.

## Environmental Specifications

Parameter	Min.	Typ.	Max.	Notes
Operating Temperature	-20 °C	-	+70 °C	Humidity: 10% RH to 100% RH Derating: 1.5% per °C from 50°C to 70°C
Storage Temperature	-40 °C	-	+85 °C	Humidity: 5% RH to 100% RH

## Safety & EMC Compliance

Safety Category	Country	Standard
CUL	USA & Canada	UL8750, UL935, UL1012, UL1310 Class 2, CSA-C22.2 No. 107.1, CSA C22.2 NO. 223-M91 Class 2
CE	Europe	EN 61347-1, EN61347-2-13
EMI Standards	Country	Notes
EN 55015	Europe	Conducted emission Test & Radiated emission Test with 6 dB margin
EMS Standards	Notes	
EN 61000-3-2	Harmonic current emissions	
EN 61000-3-3	Voltage fluctuations & flicker	
EN 61000-4-2	Electrostatic Discharge (ESD): 8 kV air discharge, 4 kV contact discharge	
EN 61000-4-3	Radio-Frequency Electromagnetic Field Susceptibility Test-RS	
EN 61000-4-4	Electrical Fast Transient / Burst-EFT	
EN 61000-4-6	Conducted Radio Frequency Disturbances Test-CS	
EN 61000-4-8	Power Frequency Magnetic Field Test	
EN 61000-4-11	Voltage Dips	
EN 61547	Electromagnetic Immunity Requirements Applies To Lighting Equipment	
ENERGY STAR Standards	Notes	
ANSI/IEEE C62.41-1991	Transient Protection, power supply shall comply with Class A operation. The line transient shall consist of seven strikes of a 100 kHz ring wave, 2.5 kV level, for both common mode and differential mode.	

## Derating Curve

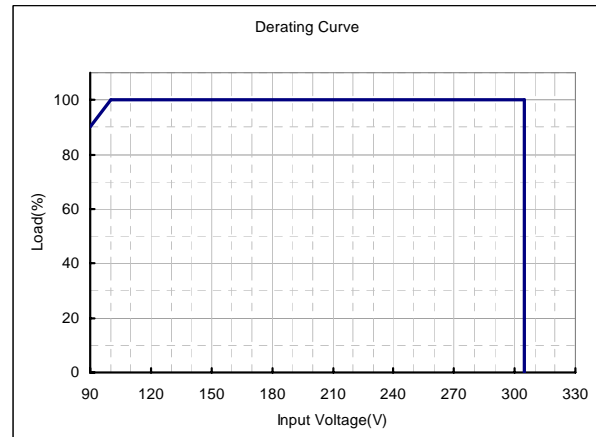
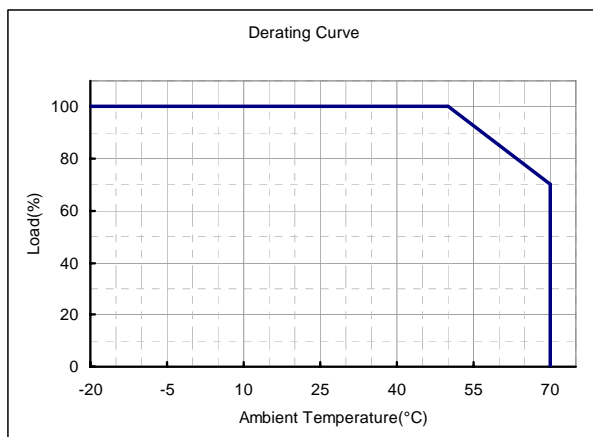

Specifications are subject to changes without notice.

## Mechanical Outline

### EUC-025SxxxPS

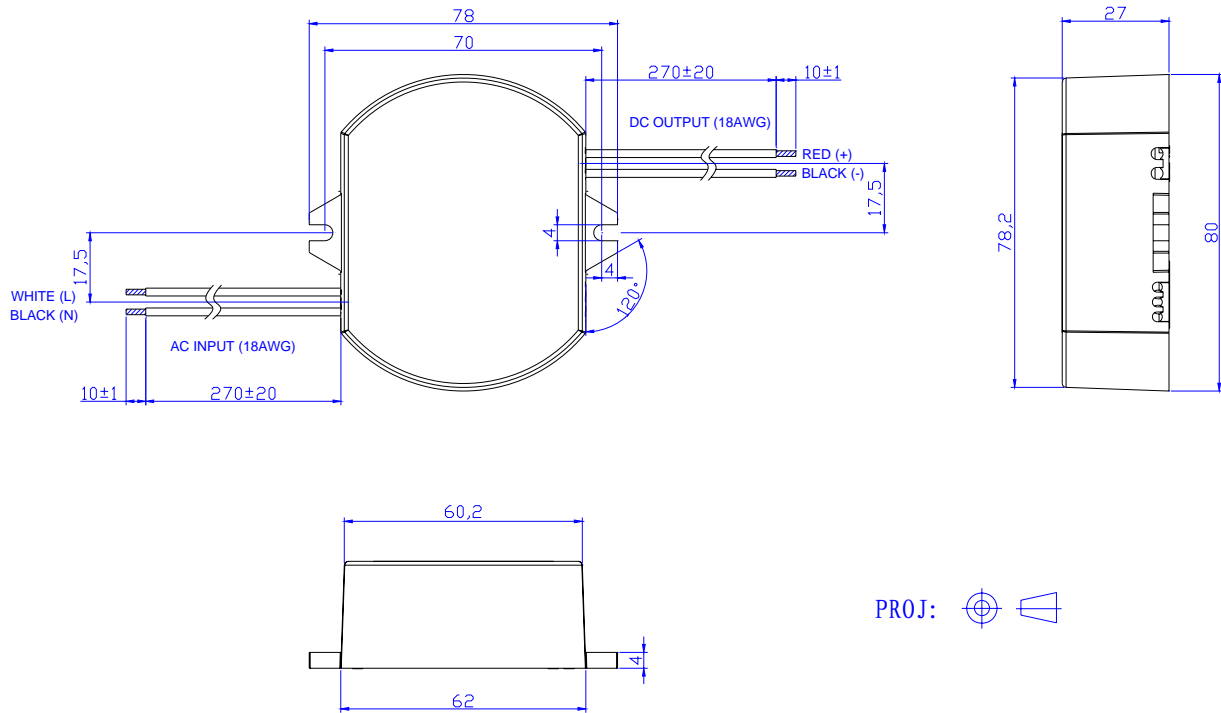

### EUC-025SxxxDS

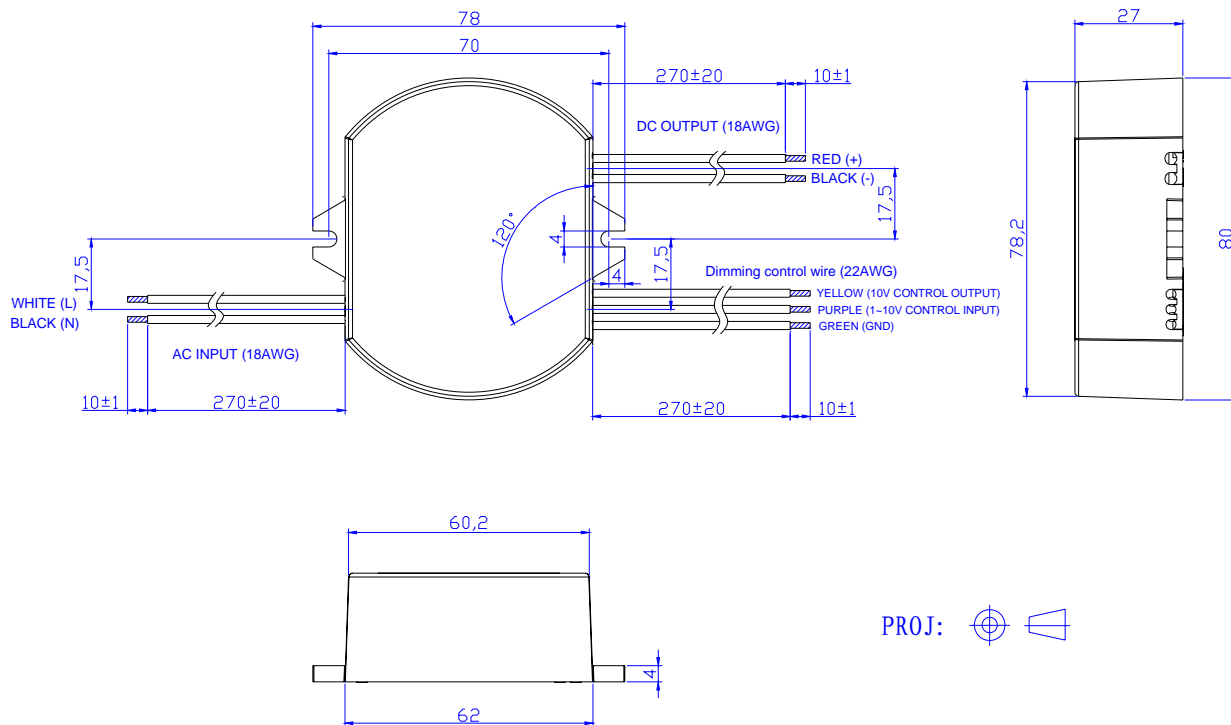

Specifications are subject to changes without notice.

## Dimming Control (On secondary side)

Parameter	Min.	Typ.	Max.	Notes
10V output voltage	9.8 V	10 V	10.2 V	
10V output source current	-10 mA	-	2 mA	
Absolute maximum voltage on the 1~10V input pin	-2 V	-	15 V	
Source current on 1~10V input pin	0 mA	-	1 mA	

The dimmer control may be operated from either a potentiometer or from an input signal of 1 – 10 Vdc. Two recommended implementations are provided below.

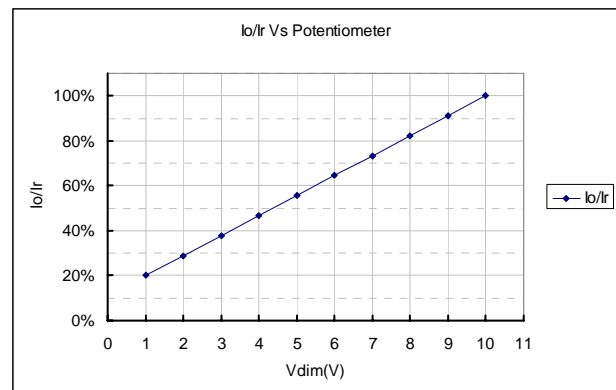
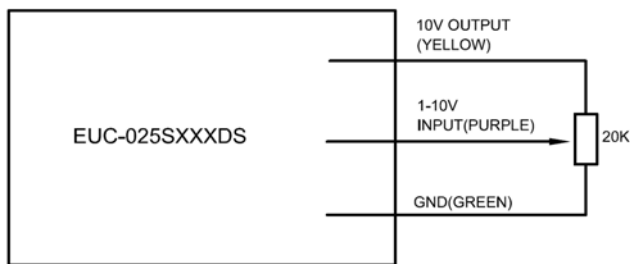

Implementation 1: Potentiometer Control

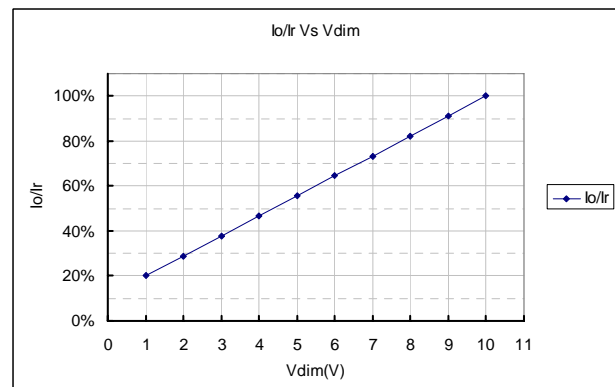
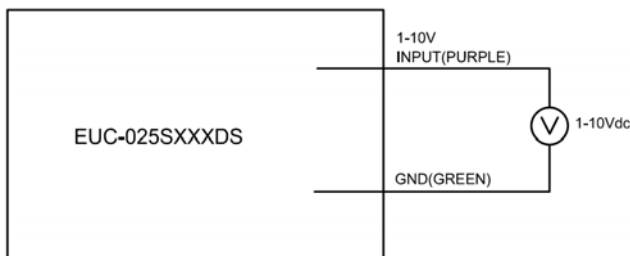

Implementation 2: DC input

### Notes:

1.  $I_o$  is actual output current and  $I_r$  is rated current.
2. If the dimming function is not used, please short 10 V output pin (yellow) and 1-10 V input pin (purple). The output current is about 92% $I_r$  when the 1-10V input pin is floating.
3. For the driver to operate properly, the load voltage must be maintained above the minimum voltage threshold (approx. 33% of the max. output voltage for any given model).
4. The dimming voltage can be tuned down to less than 1V, and the output current will be decreased to about 10% $I_r$ ; but the connected LEDs may flicker. Keeping dimming voltage greater than 1V in application is strongly recommended.
5. Do not connect the GND of dimming to the output; otherwise, the LED driver can not work normally.

## RoHS Compliance

Our products comply with the European Directive 2002/95/EC, calling for the elimination of lead and other hazardous substances from electronic products.

## Revision History

Change Date	Rev.	Description of Change		
		Item	From	To
2009-09-02	V3.2	Change MTBF and Life Time		
2009-09-11	V3.3	Change Turn-on Delay Time		
2009-12-15	A	Change Typical Efficiency and Ripple and Noise, No Load Power Dissipation		
2010-01-13	B	Modify the derating curve		
2010-04-12	C	Change the Power Factor	110Vac 0.99 220Vac 0.94	0.98 0.92
		Add Leakage Current in Input Specifications	/	Max. 0.5 mA At 277Vac 50Hz input
		Change Inrush Current	20A	60A
		Change Line Regulation	2%	3%
		Add No Load Output Voltage	/	The max. value of every model.
		Change Ripple and Noise	Max. 25% V <sub>O</sub>	The max. value of every model.
		Change Turn-on Delay Time	Typ. Max. 110Vac 1.7S 2.0S 220Vac 0.7S 1.0S	Typ. Max. 2.5S 3.0S 1.5S 2.0S
		Delete Output Overshoot / Undershoot	Max. 10%	/
		Change Over Load Protection	Typ.: 1.25P <sub>o</sub>	Typ.: 1.25 V <sub>max</sub>
		Change the efficiency (110Vac)	Min. Typ. I <sub>o</sub> = 1750 mA 78% 79% I <sub>o</sub> = 1400 mA 80% 81%	Min. Typ. 79% 80% 79% 80%
		Change the efficiency (220Vac)	Min. Typ. I <sub>o</sub> = 1750 mA 79% 80% I <sub>o</sub> = 1400 mA 81% 82%	Min. Typ. 80% 81% 80% 81%
		Change No Load Power Dissipation	≤ 5 W	≤ 6 W
		Change linearity of dimming curve	/	/
		Change the notes in Dimming Control	2. If the input voltage is within 90-175Vac, the output current can be varied from 100% down to 10%. 3. If the input voltage is within 175-305Vac, the output current can be varied from 100% down to 20%.	2. If the Dimming voltage is varied from 10V down to 0V, the output current can be varied from 100%I <sub>o</sub> down to 10%~20%I <sub>o</sub> . 3. Do not connect the GND of dimming to the output; otherwise, the LED driver can not work normally.
2010-05-31	D	Add star rank for recommended models	/	☆: Popular model.
2010-06-04	E	Change Dimensions and Mechanical Outline (The height)	25 cm	27 cm
2010-10-14	F	Change the notes in Dimming Control	/	/
		Add Energy Star Standard	/	Comply With ANSI/IEEE C62.41, Class A Operation

Specifications are subject to changes without notice.